

MERCER'S



MERCER'S

Product Catalogue 2023-2024



Product Catalogue 2023/2024

www.mercersmarine.com

IF IT'S
PAVED,
THERE'S
NOTHING
TO PROVE.

ROAM THE
UNKNOWN



TREAD
POWERSPORT NAVIGATOR

GARMIN

SALES POLICY

Mercer's Marine products may be purchased from any of our Authorized Dealers throughout Canada (Certain product exceptions may apply). For the name of the Dealer nearest you, please contact us. You can also order directly from this catalogue or our website at www.mercersmarine.com

PRICING

As we aim to publish our catalogue bi-annually, price fluctuations may be inevitable. As a business in today's modern world, we are constantly faced with the challenges of an ever-changing global market, rising inflation rates, and most recently the detrimental effects that the covid-19 pandemic has had on our economy. Therefore, in turn, we are oftentimes unable to predict nor control product price adjustments. We would however, like to highlight that our website will consistently strive to provide the most current and up-to-date price list for our customers. All prices are in Canadian dollars, and do not include shipping charges or applicable taxes.

SHIPPING

We ship by courier, transport truck, post and coastal boat. We have negotiated special rates with many carriers which we will pass on to our customers. Please note, maximum weight shippable by post is 30kg and maximum length is 2 meters. Also, all liquids, paints, pressurized containers and flares cannot be shipped by post and some carriers may charge a **Dangerous Goods Fee** for these products.

PRODUCT SPECIFICATIONS

As manufacturers reserve the right to make changes to their product without notice, we cannot be liable for the accuracy of product information. To the best of our ability, the information provided in this catalogue is believed to be correct. We, however, wish to emphasize that for total accuracy on information, manufacturer's literature can be provided by request or by visiting the manufacturer's website.

TERMS & PRIVACY

We accept cash, Visa, Mastercard, & in-store Debit Card (Interac), Please be sure to have credit card number as well as expiry date when ordering. Products will not be shipped until credit card authorization has been obtained. Your privacy is important to us! We want you to know that we hold your financial and other personal information in strict confidence. We do not sell, share or trade our customers' personal information to marketing companies or information brokers.

RETURNS, EXCHANGES & WARRANTY

1. Returned goods must include invoice number and date of purchase.
2. **Goods must be returned, prepaid, within 30 days of purchase and must be in original condition and undamaged packaging.**
3. Warranties will be as stated by manufacturer unless otherwise stated by Mercer's Marine.
4. We can not accept returns on special order items, cut hose or cut chain.

HOURS OF OPERATION

Monday - Friday 8:30 - 5:30
Saturday..... 8:30 - 5:00
Sunday Closed



www.mercersmarine.com

- Always Open
- Sale & Feature items
- View Catalogue
- Thousands of products
- Updated Regularly
- Up to date Pricing
- Mobile Friendly
- Shop from anywhere at anytime

find us on    

THE MERCER'S TEAM

The management and staff of Mercer's wish to thank you for your past business and support. We hope you enjoy browsing our catalogue, we are sure that you will agree, Mercer's is more than just marine. In addition to our catalogue, our customers can shop, 24 hours a day, at our website: www.mercersmarine.com where there is also a large selection of clothing and footwear available from the top brand names. From all of us at Mercer's, we look forward to serving you in the years ahead.



Contacts

Scott Mercer - Vice President
scott@mercersmarine.com

Steve Simmons - General Manager
steve@mercersmarine.com

Scott Baggs - Controller
scottb@mercersmarine.com

Carolyn Burton- Accounts Receivable
carolynb@mercersmarine.com

Amber Miller - Purchasing/OHS
amber@mercersmarine.com

Daren Tremblett - GPS/Electronics Mgr.
darent@mercersmarine.com

Paul Templeman - Floor Manager/Sales
paul@mercersmarine.com

Dawn Avery - Purchasing
dawn@mercersmarine.com

Steve Adams - Warehouse Manager
shipping@mercersmarine.com

Jason Bailey - Hydraulics/Sales
jasonb@mercersmarine.com

Angela Brown - Purchasing/Housewares
angelab@mercersmarine.com

Donnie Bowring - Marketing Manager
donnieb@mercersmarine.com

Skyler Ellis - Returns/Warranty
skyler@mercersmarine.com

Kim Smith - Office Administration
kims@mercersmarine.com

Mercer's Marine
210 Marine Dr.
Clareville, NL A5A 1L8

Phone: 709-466-7430
Email: info@mercersmarine.com
Fax: 709-466-7430

Also find us on





Dear Valued Customer

The management and staff at Mercer's Marine are pleased to announce yet another publication of their traditional, user-friendly catalogue. As a proudly owned and operated 4th generation business in Newfoundland and Labrador (est.1957), we are always pleased to offer our much-appreciated customers a detailed and comprehensive publication of what our very diverse store has to offer. Since 1981, Mercer's has placed much dedication on its catalogue production, of which to date has been released every two years.

In addition, we are delighted to invite our customers to check out our website at www.mercersmarine.com. Here, our customers will find the most current up-to-date pricing, as well as our "live inventory" browsing, which allows customers to see current "in stock" and "out of stock" items. Due to ever-changing fashion trends and seasonal product transitioning, our website displays many clothing and footwear lines that are not included in our catalogue.

We would also like to inform our customers that mercersmarine.com is a mobile friendly online site. Shop 24/7 anytime/anywhere from your smartphone, tablet etc. Check us out on facebook/Instagram/tiktok to see what's currently trending at Mercers Marine!

We also suggest dropping by our store, meeting our staff, and enjoying a unique and pleasurable experience. We wish to thank you for your past support and hope to see or hear from you soon. If you have any questions or concerns about ordering from our website please contact our Website Manager, Donnie Bowring for assistance.

Best Regards

From the Management & Staff at Mercer's

210 Marine Drive, Clarenville, NL A5A 1L8

Tel: 709.466.7430 Fax: 709.466.3279 www.mercersmarine.com info@mercersmarine.com

Prices are subject to change. Check our website for up to date prices. www.mercersmarine.com



STAINLESS STEEL SCREWS

Flat head, full size, full thread square socket, 18-8 stainless screws.

Ord.No.	Size	Price/100
62-000T	#6 x 1/2"	7.00
62-001T	#6 x 3/4"	8.10
62-002T	#6 x 1"	9.35
62-710T	#6 x 1 1/2"	12.00
62-003T	#8 x 3/4"	10.35
62-004T	#8 x 1"	10.30
62-005T	#8 x 1 1/4"	11.55
62-006T	#8 x 1 1/2"	16.25
62-344T	#8 x 2"	18.30
62-711T	#8 x 2 1/2"	26.75
62-007T	#10 x 3/4"	12.95
62-008T	#10 x 1"	12.75
62-009T	#10 x 1 1/4"	17.85
62-010T	#10 x 1 1/2"	15.90
62-011T	#10 x 1 3/4"	23.80
62-012T	#10 x 2"	22.75
62-339T	#10 x 2 1/2"	33.80
62-340T	#10 x 3"	37.75
62-013T	#12 x 1 1/4"	26.70
62-014T	#12 x 1 1/2"	27.35
62-015T	#12 x 1 3/4"	36.65
62-016T	#12 x 2"	36.45
62-341T	#12 x 2 1/2"	34.25
62-342T	#12 x 3"	46.35
62-018T	#14 x 1 1/4"	24.60
62-019T	#14 x 1 1/2"	36.05
62-021T	#14 x 2"	45.85
62-023T	#14 x 2 1/2"	94.75
62-343T	#14 x 3"	64.60



STAINLESS STEEL SCREWS

Pan head, Square socket drive, 18-8 tapping screws.

Ord.No.	Size	Price/100
62-027T	#6 x 1/2"	6.45
62-028T	#6 x 3/4"	7.55
62-568T	#6 x 1 1/2"	10.75
62-029T	#8 x 1/2"	8.50
62-030T	#8 x 3/4"	12.15
62-031T	#8 x 1"	11.45
62-567T	#8 x 1 1/4"	20.20
62-032T	#10 x 3/4"	15.65
62-033T	#10 x 1"	24.05
62-034T	#10 x 1 1/4"	27.20
62-035T	#10 x 1 1/2"	30.90
62-036T	#10 x 2"	24.85
62-037T	#12 x 1 1/2"	33.95
62-038T	#12 x 2"	44.95
62-039T	#12 x 2 1/2"	65.00
62-040T	#14 x 2"	54.20



STAINLESS STEEL LAG SCREWS

18-8 Stainless Steel

Ord. #	Size	Price (ea)
62-392T	1/4" x 1"	0.35
62-163T	1/4" x 1 1/2"	0.54
62-346T	1/4" x 2"	0.69
62-238T	1/4" x 2 1/2"	0.90
62-347T	1/4" x 3"	1.00
62-530T	1/4" x 4"	1.45
62-164T	5/16" x 2"	1.15
62-165T	5/16" x 3"	1.46
62-348T	5/16" x 4"	1.86
62-166T	3/8" x 2"	1.57
62-167T	3/8" x 3"	2.12
62-349T	3/8" x 4"	2.76
62-350T	3/8" x 5"	3.54
62-359T	1/2" x 2"	3.06
62-351T	1/2" x 3"	4.29
62-168T	1/2" x 4"	5.44
62-169T	1/2" x 5"	6.36
62-352T	1/2" x 6"	7.62



STAINLESS STEEL CARRIAGE BOLTS

18-8 Stainless Steel

Ord. #	Size	Price (ea)
62-367T	1/4" x 1 1/2"	0.54
62-150T	1/4" x 2"	0.63
62-368T	1/4" x 2 1/2"	0.91
62-151T	1/4" x 3"	1.02
62-152T	1/4" x 4"	1.09
62-153T	5/16" x 2"	1.17
62-154T	5/16" x 3"	1.51
62-155T	5/16" x 3 1/2"	1.68
62-369T	5/16" x 4"	1.84
62-156T	3/8" x 2"	1.53
62-157T	3/8" x 3"	2.05
62-158T	3/8" x 4"	2.78
62-159T	3/8" x 5"	3.49
62-360T	3/8" x 6"	3.87
62-370T	1/2" x 3"	3.63
62-160T	1/2" x 4"	4.89
62-161T	1/2" x 5"	6.28
62-162T	1/2" x 6"	8.15



THREADED ROD

18-8 Stainless Steel

Ord. #	Size	Price/ea.
62-179R	1/4" x 3 ft.	8.40
62-180R	5/16" x 3 ft.	11.55
62-181R	3/8" x 3 ft.	16.70
62-182R	1/2" x 3 ft.	30.60
62-183R	5/8" x 3 ft.	46.70
62-184R	3/4" x 3 ft.	85.75
62-543R	1/2" x 6 ft.	72.90
62-544R	5/8" x 6 ft.	77.60
62-545R	3/4" x 6 ft.	180.20



S.S. FINISH WASHERS

Ord. #	Size	Price (ea)
62-041T	#8	0.09
62-042T	#10	0.11
62-043T	#12	0.11
62-044T	1/4"	0.23



HEX HEAD MACHINE BOLTS 18-8 STAINLESS STEEL

Ord. #	Size	Price (ea)
62-045T	1/4" x 1/2"	0.30
62-046T	1/4" x 1"	0.34
62-047T	1/4" x 1 1/2"	0.49
62-048T	1/4" x 2"	0.61
62-049T	1/4" x 2 1/2"	0.76
62-050T	1/4" x 3"	0.94
62-051T	1/4" x 4"	0.96
62-052T	5/16" x 1"	0.58
62-053T	5/16" x 1 1/2"	0.78
62-054T	5/16" x 2"	0.97
62-055T	5/16" x 2 1/2"	1.28
62-560T	5/16" x 2 3/4"	1.25
62-056T	5/16" x 3"	1.42
62-381T	5/16" x 3 1/4"	1.44
62-057T	5/16" x 3 1/2"	1.74
62-058T	5/16" x 4"	1.83
62-059T	3/8" x 1"	0.84
62-394T	3/8" x 1 1/4"	0.94
62-060T	3/8" x 1 1/2"	1.10
62-061T	3/8" x 2"	1.34
62-062T	3/8" x 2 1/2"	1.71

Ord. #	Size	Price (ea)
62-063T	3/8" x 3"	2.01
62-733T	3/8" x 3 1/4"	1.34
62-064T	3/8" x 3 1/2"	2.33
62-065T	3/8" x 4"	2.65
62-066T	3/8" x 5"	3.53
62-067T	3/8" x 6"	4.33
62-068T	7/16" x 1"	1.34
62-380T	7/16" x 1 1/4"	1.47
62-069T	7/16" x 1 1/2"	1.55
62-070T	7/16" x 2"	2.11
62-071T	7/16" x 2 1/2"	2.71
62-072T	7/16" x 3"	2.68
62-073T	7/16" x 4"	1.87
62-074T	7/16" x 5"	4.65
62-075T	1/2" x 1"	1.88
62-566T	1/2" x 1 1/4"	1.93
62-076T	1/2" x 1 1/2"	2.06
62-077T	1/2" x 2"	2.58
62-078T	1/2" x 2 1/2"	3.22
62-079T	1/2" x 3"	3.74
62-080T	1/2" x 4"	4.79

Ord. #	Size	Price (ea)
62-081T	1/2" x 5"	6.02
62-082T	1/2" x 6"	7.45
62-083T	5/8" x 1"	2.56
62-084T	5/8" x 2"	4.28
62-562T	5/8" x 2 1/4"	2.24
62-085T	5/8" x 2 1/2"	5.22
62-086T	5/8" x 3"	6.53
62-087T	5/8" x 4"	8.36
62-088T	5/8" x 5"	9.97
62-089T	5/8" x 6"	10.82
62-090T	3/4" x 2"	7.33
62-091T	3/4" x 2 1/2"	8.21
62-092T	3/4" x 3"	9.95
62-093T	3/4" x 4"	11.69
62-094T	3/4" x 5"	14.30
62-095T	3/4" x 6"	18.64

For #316 Stainless Steel hex head bolts, nuts and washers, Visit our website at www.mercersmarine.com



SLOTTED HEAD



FLAT HEAD MACHINE SCREWS

18-8 Stainless Steel	Price/ea.
62-123T	6-32 x 1/2" 0.08
62-124T	6-32 x 3/4" 0.08
62-125T	6-32 x 1" 0.13
62-126T	6-32 x 1 1/2" 0.18
62-127T	8-32 x 1/2" 0.09
62-128T	8-32 x 3/4" 0.13
62-129T	8-32 x 1" 0.16
62-130T	8-32 x 1 1/2" 0.22
62-131T	10-32 x 1/2" 0.14
62-132T	10-32 x 3/4" 0.21
62-133T	10-32 x 1" 0.18
62-134T	10-32 x 1 1/2" 0.17
62-135T	10-32 x 2" 0.51
62-366T	1/4" x 1/2" 0.29
62-139T	1/4" x 1" 0.50
62-140T	1/4" x 1 1/2" 0.66
62-141T	1/4" x 2" 0.86
62-142T	1/4" x 2 1/2" 1.03
62-143T	1/4" x 3" 1.361
62-144T	1/4" x 4" 1.73
62-145T	5/16" x 1" 0.80
62-146T	5/16" x 1 1/2" 1.22
62-147T	5/16" x 2" 1.43
62-148T	5/16" x 3" 1.63



SLOTTED HEAD



ROUND HEAD MACHINE SCREWS

18-8 Stainless Steel	Price/ea.
62-096T	6-32 x 1/2" 0.08
62-097T	6-32 x 3/4" 0.10
62-098T	6-32 x 1" 0.10
62-099T	6-32 x 1 1/2" 0.12
62-100T	8-32 x 1/2" 0.13
62-101T	8-32 x 3/4" 0.17
62-102T	8-32 x 1" 0.19
62-103T	8-32 x 1 1/2" 0.23
62-104T	10-32 x 1/2" 0.15
62-105T	10-32 x 3/4" 0.19
62-106T	10-32 x 1" 0.22
62-107T	10-32 x 1 1/2" 0.25
62-108T	10-32 x 2" 0.32
62-363T	1/4" x 1/2" 0.22
62-112T	1/4" x 1" 0.39
62-113T	1/4" x 1 1/2" 0.47
62-114T	1/4" x 2" 0.62
62-115T	1/4" x 2 1/2" 0.71
62-116T	1/4" x 3" 0.81
62-117T	1/4" x 4" 1.84

SHOP 24/7 FROM THE COMFORT OF YOUR OWN HOME

- Up to date Pricing
- New Products
- Stock Status
- Additional product info
- And more



www.mercersmarine.com

COMMERCIAL FISHING GEAR

S.S. HEX NUTS

18-8 STAINLESS STEEL		Price/ea.
62-170T6-32	0.08
62-171T8-32	0.11
62-172T10-32	0.08
62-173T12-24	0.13
62-174T1/4"	0.13
62-175T5/16"	0.18
62-176T3/8"	0.26
62-177T7/16"	0.60
62-178T1/2"	0.61
62-330T5/8"	1.12
62-331T3/4"	1.88



S.S. NYLON INSERT LOCKNUTS

18-8 STAINLESS STEEL		Price/ea.
62-185T6-32	0.13
62-186T8-32	0.13
62-187T10-32	0.16
62-188T1/4"	0.22
62-189T5/16"	0.31
62-190T3/8"	0.43
62-191T7/16"	0.94
62-192T1/2"	1.50
62-193T5/8"	2.42
62-194T3/4"	5.07



S.S. ACORN CAP NUTS

18-8 STAINLESS STEEL		Price/ea.
62-353T6-32	0.18
62-354T8-32	0.25
62-355T10-32	0.39
62-356T1/4"	0.50
62-357T5/16"	0.55
62-358T3/8"	1.18
62-698T1/2"	1.20



S.S. LOCK WASHERS

18-8 STAINLESS STEEL		Price/ea.
62-213T# 8	0.05
62-214T# 10	0.04
62-215T# 12	0.07
62-216T1/4"	0.07
62-217T5/16"	0.10
62-218T3/8"	0.13
62-219T7/16"	0.63
62-220T1/2"	0.83
62-221T5/8"	1.33
62-222T3/4"	2.13



S.S. FLAT WASHERS

18-8 STAINLESS STEEL		Price/ea.
62-203T# 8	0.04
62-204T# 10	0.04
62-205T# 12	0.16
62-206T1/4"	0.07
62-207T5/16"	0.09
62-208T3/8"	0.11
62-209T7/16"	0.23
62-210T1/2"	0.26
62-211T5/8"	0.43
62-212T3/4"	1.33
62-529T1"	0.97
62-719T1 1/8"	2.97
62-720T1 1/4"	1.72
62-721T1 1/2"	2.35



S.S. WING NUTS

18-8 STAINLESS STEEL		Price/ea.
62-195T6-32	0.19
62-196T8-32	0.36
62-197T10-32	0.41
62-198T1/4"	0.67
62-199T5/16"	0.81
62-200T3/8"	1.46
62-202T1/2"	4.44



For #316 Stainless Steel hex head bolts, nuts and washers, Visit our website at www.mercersmarine.com



HAND RIVET GUN & RIVETS

Professional hand riveter complete with wrench. Accepts up to 3/16" rivets.
20-1702M.....15.95

STAINLESS STEEL RIVETS

18-8 Stainless steel domed head. Stainless rivet and stainless mandrel.

1/8" Diameter

Ord. No.	Grip	Price ea.
62-513T1/16" - 1/8"	0.12
62-514T1/8" - 3/16"	0.15
62-515T3/16" - 1/4"	0.15
62-516T5/16" - 3/8"	0.18

3/16" Diameter

62-517T1/16" - 1/8"	0.25
62-518T1/8" - 1/4"	0.28
62-519T1/4" - 3/8"	0.34
62-520T3/8" - 1/2"	0.34

STAINLESS STEEL CLEVIS PIN

18-8 STAINLESS STEEL		
62-521T3/16" x 5/8"	1.15/ea
62-522T3/16" x 1"	2.70/ea
62-523T1/4" x 3/4"	1.20/ea
62-524T1/4" x 1"	2.70/ea
62-525T5/16" x 1"	1.65/ea



Want to receive e-mail updates from Mercer's Marine? Subscribe at mercersmarine.com





GALVANIZED CARRIAGE BOLTS		Price/ea.
62-229R	1/4" x 2"	0.15
62-230R	1/4" x 2 1/2"	0.18
62-231R	1/4" x 3"	0.24
62-232R	1/4" x 3 1/2"	0.26
62-233R	1/4" x 4"	0.27
62-234R	1/4" x 4 1/2"	0.30
62-235R	1/4" x 5"	0.32
62-236R	1/4" x 6"	0.35
62-239R	5/16" x 2"	0.24
62-240R	5/16" x 2 1/2"	0.27
62-241R	5/16" x 3"	0.31
62-242R	5/16" x 3 1/2"	0.44
62-243R	5/16" x 4"	0.43
62-373R	5/16" x 4 1/2"	0.47
62-244R	5/16" x 5"	0.50
62-245R	5/16" x 6"	0.61
62-248R	3/8" x 2"	0.42
62-249R	3/8" x 2 1/2"	0.39
62-250R	3/8" x 3"	0.53
62-251R	3/8" x 3 1/2"	0.51
62-252R	3/8" x 4"	0.61
62-253R	3/8" x 4 1/2"	0.63
62-254R	3/8" x 5"	0.74
62-255R	3/8" x 5 1/2"	0.82
62-256R	3/8" x 6"	0.80
62-379R	3/8" x 6 1/2"	0.85
62-257R	3/8" x 7"	1.22
62-258R	3/8" x 8"	1.14
62-260R	3/8" x 10"	1.41
62-262R	3/8" x 12"	1.66
62-263R	3/8" x 14"	1.99
62-264R	1/2" x 4"	1.07
62-265R	1/2" x 5"	1.71
62-266R	1/2" x 6"	1.77
62-267R	1/2" x 7"	1.83
62-268R	1/2" x 8"	1.93
62-269R	1/2" x 9"	2.34
62-270R	1/2" x 10"	2.32
62-272R	1/2" x 12"	2.72
62-273R	1/2" x 14"	3.43
62-279R	5/8" x 6"	2.50
62-280R	5/8" x 8"	3.26
62-281R	5/8" x 10"	4.55
62-282R	5/8" x 12"	4.64
62-283R	5/8" x 14"	7.64



GALVANIZED LAG SCREWS		Price/ea.
62-289R	1/4" x 2"	0.18
62-374R	1/4" x 2 1/2"	0.26
62-375R	1/4" x 3"	0.28
62-377R	1/4" x 4"	0.34
62-378R	1/4" x 5"	0.32
62-290R	5/16" x 2"	0.26
62-291R	5/16" x 2 1/2"	0.33
62-292R	5/16" x 3"	0.42
62-293R	5/16" x 4"	0.56
62-329R	3/8" x 1 1/2"	0.35
62-294R	3/8" x 2"	0.42
62-295R	3/8" x 2 1/2"	0.51
62-296R	3/8" x 3"	0.70
62-297R	3/8" x 4"	0.74
62-298R	3/8" x 5"	0.82
62-334R	3/8" x 6"	0.77
62-299R	1/2" x 2"	0.58
62-300R	1/2" x 3"	0.80
62-301R	1/2" x 4"	1.00
62-302R	1/2" x 5"	1.16
62-303R	1/2" x 6"	1.79
62-336R	1/2" x 8"	2.24
62-314R	1/2" x 10"	2.43
62-315R	1/2" x 12"	2.77
62-304R	5/8" x 5"	1.80
62-305R	5/8" x 6"	2.32
62-306R	5/8" x 8"	2.92
62-316R	5/8" x 10"	3.76
62-317R	5/8" x 12"	4.84
62-319R	3/4" x 8"	4.91
62-320R	3/4" x 10"	5.78
62-321R	3/4" x 12"	7.40



GALVANIZED HEX NUTS		Price/ea.
62-307R	1/4"	0.04
62-308R	5/16"	0.06
62-309R	3/8"	0.08
62-310R	1/2"	0.20
62-311R	5/8"	0.40
62-312R	3/4"	0.60



GALVANIZED FLAT WASHERS		Price/ea.
62-223R	1/4"	0.04
62-224R	5/16"	0.08
62-225R	3/8"	0.11
62-226R	1/2"	0.20
62-227R	5/8"	0.37
62-228R	3/4"	0.71



HOT GALVANIZED NAILS		
Ord.No.	Size	Price/ea.
62-798K	6"	0.66
62-799K	8"	1.60
62-800K	10"	1.90
62-801K	12"	1.91



Reg Price
\$3.60/lb



GALVANIZED SHIP SPIKES		Approx.	Price
Ord.No.	Size	# per lb.	
62-395A	5/16" x 3"	12 pcs.	1.99/lb
62-396A	5/16" x 4"	10 pcs.	1.99/lb
62-408A	5/16" x 5"	8 pcs.	1.99/lb



WRECKING BAR (GOOSE NECK)		Price
52-708P	18"	10.95
52-709P	24"	15.50
52-710P	30"	19.50
52-711P	36"	21.95



Commercial Fishing Gear



TYPICAL HYDRAULIC INSTALLATION

A typical installation employs the simplest of hydraulic circuits. Minimizing the number and complexity of the components increases the system's reliability and durability, keeps costs to a minimum, and makes them easier to install and operate. Power to drive the hydraulic pump most often comes from the vessel's engine through a belt or direct system (with or without an electric clutch), but can also be provided by an auxiliary engine or, as in the case of an outboard engine powered or unpowered vessel, a portable hydraulic power unit that combines an engine, hydraulic pump, tank and filter in a single, compact unit.

1. Head Assembly
2. Work Lines - high pressure
3. Control Handle
4. Control Handle Connector
5. Control Valve
6. Hydraulic Fluid Tank
7. In-Line Filter
8. Return Line - low pressure
9. Pump Discharge line - high pressure
10. Pump Suction line - low pressure
11. Hydraulic Pump
12. Pump Mount Bracket

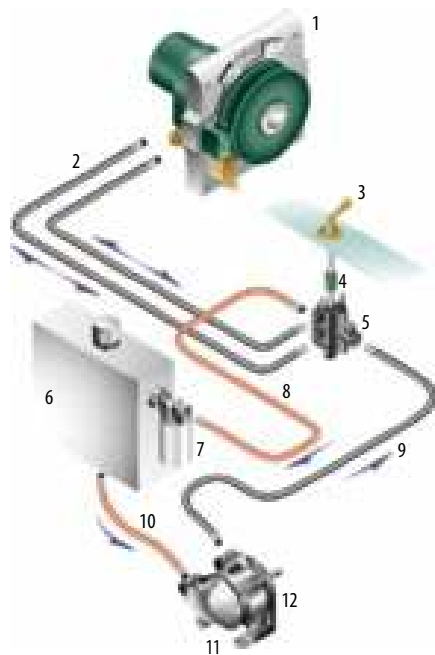

10" 90° HEAD ASSEMBLY

Maximum line pull 390lbs., maximum line speed 1060 fpm. Complete with 6 cu. in. displacement motor, cast iron aluminum mounting plate, cast bronze hub, painted steel discs, cast iron splitter, cast bronze rope deflector, and cast aluminum hub cover. Hydraulic motor fittings included. Shipping weight - 32 lbs.

44-452KChar-Lynn 101-1003P.O.R.



12" 90° HEAD ASSEMBLY

Maximum line pull 900lbs., maximum line speed 320 fpm. High torque model, used for hauling crab pots in deeper waters. Complete with cast aluminum mounting plate. This model has a 23 cu.in. displacement motor, cast bronze hub, painted steel discs, and a cast iron splitter. Hydraulic motor fittings included.

44-926KChar-Lynn 101-1008P.O.R.

Maximum line pull 585 lbs., maximum line speed 630 fpm. As above except with 12 cu.in. displacement motor. Shipping weight - 43 lbs.

44-453KChar-Lynn 101-1005P.O.R.



14" 90° HEAD ASSEMBLY

Maximum line pull 1500lbs., maximum line speed 390 fpm. Complete with 30 cu.in. displacement motor, cast aluminum mounting plate, stainless steel hub, painted steel discs, cast iron splitter, cast bronze rope deflector, and stainless steel hub cover. Hydraulic motor fittings included. Shipping weight - 76 lbs.

44-455KChar-Lynn 104-1434P.O.R.



10" HANGING HEAD ASSEMBLY

Maximum line pull 390 lb. Maximum line speed 1060 fpm. Complete with cast aluminum mounting plate with swivel eye. 6 cu.in. displacement motor, cast bronze hub, painted steel discs, and cast iron splitter. Hydraulic motor fittings included. Shipping weight - 43 lbs.

44-520KChar-Lynn 101-1003P.O.R.



12" HANGING HEAD ASSEMBLY

Maximum line pull 950 lb. Maximum line speed 315 fpm. High torque model designed especially for crab fishing and other applications where heavy line pull is needed. Complete with cast aluminum mounting plate with swivel eye, 23 cu.in. heavy duty displacement motor, cast bronze hub, painted steel discs, and cast iron splitter. Hydraulic motor fittings included. Shipping weight - 51 lbs.

44-470KChar-Lynn 103-1008P.O.R.

Maximum line pull 900 lbs. Maximum line speed 320 fpm. Same as above except with 23 cu.in. displacement motor. Shipping weight - 48 lbs.

44-469KChar-Lynn 101-1008P.O.R.

Maximum line pull 585 lb. Maximum line speed 630 fpm. Same as above except with 11 cu. in. displacement motor. Shipping weight - 44 lbs.

44-445KChar-Lynn 101-1005P.O.R.



14" HANGING HEAD ASSEMBLY

Maximum line pull 1500 lb.
 Maximum line speed 390 fpm. Still the mainstay of the inshore crab fishery. Has stainless steel hub to withstand the strongest pulls. Complete with cast aluminum mounting plate with swivel eye. 30 cu. in. displacement motor, stainless steel hub, painted steel discs, and cast iron splitter. Hydraulic motor fittings included. Shipping weight - 103 lbs.

- 44-446KChar-Lynn 104-1434P.O.R.
- 44-447KExcel 30.....P.O.R.



15" HANGING HEAD ASSEMBLY

Extra heavy duty cast iron discs. Cast bronze hub and machined grease passage. Hub and motor shaft are protected by a stainless steel hub cover with grease fitting and neoprene gasket. Also accepts any of the motors currently offered on our 14" haulers. Shipping weight 182 lbs.

- Maximum line pull 2050 lbs.**
- Maximum line speed 340 fpm. 30 cu. in.
- 44-1502KParker TFO-475P.O.R.



17" HANGING HEAD ASSEMBLY

Maximum line pull 2500 lb.
 Maximum line speed 480 fpm. The ultimate when nothing less will do. Handles the deepest and heaviest hauls with ease. Complete with cast aluminum mounting plate with swivel eye. 60 cu. in. displacement motor, cast bronze hub, painted steel discs, and cast iron splitter. Hydraulic motor fittings included. Shipping weight - 230 lbs.

- 44-448KChar-Lynn 112-1069P.O.R.



FAIRLEAD ROLLERS

Solid machined aluminum rollers with bronze bushings and stainless steel shafts.

- 44-449K3" dia. -10" & 12" old style94.00
- 44-950K3" dia - 12" new style111.00
- 44-450K4" dia - 14" heads133.00
- 44-036K5" dia - 15" heads205.00
- 44-451K5" dia - 17" heads 216.00



REINFORCING DISC

A steel disc used on the outside of the plates on a 14" crab hauler. Strengthens plates and prevents cracking of plates around the bolt holes.

- 44-549K14" only 148.00 ea.



DISC LINERS

The perfect item to protect your hauler head investment. Simply install a pair of these between your hauler discs and replace these liners as they wear, not your hauler discs. Made from 1/16" thick steel and galvanized for corrosion resistance, inside surfaces of liners are scored to avoid line slippage.

- 44-742K10" Liners46.00/pr.
- 44-743K12" Liners42.50/pr.
- 44-744K14" Liners53.95/pr.

LOOKING FOR HAULER PARTS?
 They are listed on our website with the latest inventory and pricing

Hauler Head Assembly Replacement Parts

Head Assembly Size	10" Item #	12" Item #	14" Item #	15" Item #	17" Item #
1 90° Mounting Plate, aluminum	44-300K 457.00	44-301K 670.00	44-302K 908.00	-----	-----
Hanging style Mounting Plate	44-653K 777.00	44-359K 882.00	44-360K 1585.00	44-1201K 2240.00	44-361K 3050.00
Replacement eyebolt kit	-----	44-1079K 67.00	44-714K 92.00	44-714K 92.00	-----
2 Hub, cast bronze	44-323K 357.00	44-324K 419.00	-----	44-1203K 1161.00	44-326K 1520.00
Hub, stainless steel	-----	44-327K 334.00	44-328K 334.00	-----	-----
Hub washer, stainless steel	-----	-----	-----	44-1210K 16.50	44-357K 0.95
3 Discs, painted steel, set of 2	44-303K 91.00	44-314K 154.00	44-315K 258.00	-----	44-316K 1094.00
Discs, stainless steel, set of 2	44-579K 175.00	44-317K 278.00	44-318K 698.00	-----	-----
Discs, cast iron, set of 2	-----	-----	-----	44-1202K 975.00	-----
Reinforcing disc, each	-----	-----	44-549K 148.00	-----	-----
4 Disc shim 1/32" thick, each	44-355K 2.95	44-356K 3.50	44-356K 3.50	-----	-----
Disc shim 1/16" thick, each	44-330K 4.50	44-331K 5.95	44-331K 5.95	44-354K 8.95	44-332K 8.75
5 Hub cover gasket	44-388K 7.95	44-389K 6.25	44-389K 6.25	44-390K 8.95	44-390K 8.95
6 Hub cover, stainless steel	-----	44-335K 28.00	44-335K 28.00	44-1206K 60.00	44-336K 60.00
Hub cover, aluminum	44-362K 61.00	-----	-----	-----	-----
7 Disc bolts, each	62-059T 0.84	62-068T 1.34	62-566T 1.93	62-078T 3.22	62-077T 2.58
Disc bolt washers, hanging heads	-----	62-219T 0.63	62-220T 0.83	-----	-----
8 Splitter shim 1/32" thick, each	44-396K 1.75	44-396K 1.75	44-396K 1.75	44-397K 3.95	-----
Splitter shim 1/16" thick, each	44-333K 2.35	44-333K 2.35	44-333K 2.35	44-398K 3.50	44-334K 3.95
9 Splitter, cast iron	44-319K 48.50	44-320K 50.95	44-321K 49.95	44-1204K 106.00	44-322K 116.00
10 90° Splitter bolts, each	62-055T 1.28	62-560T 1.25	62-056T 1.42	-----	-----
Hanging Splitter bolts, each	62-056T 1.42	62-381T 1.44	62-057T 1.74	62-730T 1.95	62-066T 3.53
Hanging Splitter bolt nuts, ea.	62-175T 0.18	62-175T 0.18	62-175T 0.18	62-175T 0.18	62-176T 0.26
11 Rope deflector assembly	44-329K 131.00	44-358K 131.00	44-358K 131.00	-----	-----
12 Motor mount bolts, each	62-559T 0.55	62-559T 0.55	62-383T 1.65	62-383T 1.65	62-384T 3.95
Motor mount bolt nuts, each	-----	-----	62-178T 0.61	62-178T 0.61	-----
13 Hydraulic motor fittings	44-234P 4.95	44-234P 4.95	44-241P 8.50	44-249P 7.95	44-243P 9.50

Hauler Head Assembly Replacement Parts

Please use the chart above to select the correct part for your hauler head assembly. This diagram is intended as a guide only. Multiple items are available in various different materials. Make sure you choose the correct part number you need for the material you require. The quantities required for some parts such as shims and bolts vary for different head assemblies.

- 1.) Backing Plate
- 2.) Hub
- 3.) Disc Set
- 4.) Disc Shims
- 5.) Hub Cover Gasket
- 6.) Hub Cover
- 7.) Disc Bolts
- 8.) Splitter Shim
- 9.) Splitter
- 10.) Splitter Bolts
- 11.) Rope Deflector Assembly
- 12.) Motor Mount Bolts
- 13.) Motor Fittings

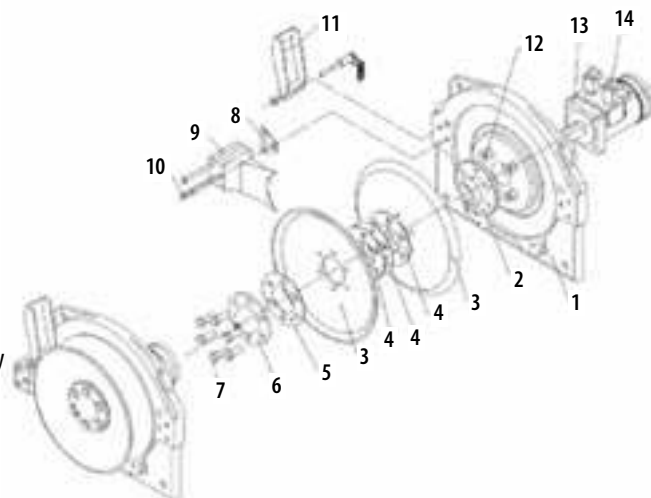



CHAR-LYNN HYDRAULIC MOTORS

Displ. Order No.	Model	Cu. in./rev.	Max. psi	Max. gpm	RPM	Shaft torque	Port size	Shaft size	Price
44-306K	101-1003	5.9	1800	15	578	1368	1/2" NPT	1"	515.00
44-307K	101-1005	11.3	1600	15	302	2337	1/2" NPT	1"	620.00
44-308K	101-1006	14.1	1450	15	243	2650	1/2" NPT	1"	614.00
44-498K	101-1007	17.9	1350	15	192	3110	1/2" NPT	1"	649.00
44-309K	101-1008	22.6	1250	15	152	3604	1/2" NPT	1"	649.00
44-473K	103-1005	11.9	2000	15	281	3178	1/2" NPT	1"	838.00
44-474K	103-1006	14.9	1850	15	226	3633	1/2" NPT	1"	855.00
44-475K	103-1008	22.6	1300	15	150	3811	1/2" NPT	1"	890.00
44-310K	104-1440	18.7	3000	20	246	6750	5/8" ORB	1 1/4"	1175.00
44-340K	104-1434	30	2000	20	149	7470	5/8" ORB	1 1/4"	1420.00
44-476K	112-1068	29.9	3000	40	307	12800	1" ORB	1 1/2"	2995.00
44-477K	112-1069	60	2000	40	153	14920	1" ORB	1 1/2"	3395.00

SEAL KITS

44-466K	Char-Lynn 101-1001-007 to 101-1008-007 old style seal kit (model 60023)								106.95
44-467K	Char-Lynn 104-1440 & 104-1434 seal kit (model 61258)								174.95
44-468K	Char-Lynn 101-1001-009/010 to 101-1008-008/010 current style seal kit (model 60540)								119.95
44-929K	Char-Lynn 103 series seal kit (model 60539)								124.95



TIER-2



TIER 2 HYDRAULIC MOTORS

Displ. Order No.	Model	Cu. in./rev.	Max. psi	Max. gpm	RPM	Shaft torque	Port size	Shaft size	Price
44-715K	BMRS-100P4C1Y5	6.1	2500	16	595	2090	5/8" ORB	1"	339.00
44-716K	BMRS-200P4C1Y5	12.22	2500	16	295	3980	5/8" ORB	1"	355.00
44-717K	BMRS-250P4C1Y5	15.27	2000	16	235	4160	5/8" ORB	1"	369.00
44-718K	BMRS-315P4C1Y5	19.24	1600	16	185	4160	5/8" ORB	1"	379.00
44-719K	BMRS-400P4C1Y5	24.43	1300	16	150	4160	5/8" ORB	1"	399.00
44-725K	BM3Y-315P11AIVY5/T11	19.24	2900	20	230	5531	5/8" ORB	1 1/4"	920.00
44-726K	BM3Y-500P11AIVY5/T11	30.54	1750	20	155	7880	5/8" ORB	1 1/4"	920.00





GALTECH CONTROL VALVE (Q-35 SERIES)

This 3 position valve has a maximum flow rate of 12 gpm and a maximum pressure rating of 3000psi. Great for smaller hydraulic system needs. The main line has a #8 ORB in port with a #8 ORB out. The work lines are #8 ORB. Valve comes complete with handle.

- 44-1518K.....3 Position Detent365.00
- 44-1519K.....3 Position Spring Centre295.00



GALTECH CONTROL VALVE (Q-75 SERIES)

This marine grade valve has a maximum flow rate of 22 gpm, with a maximum pressure rating of 3625 psi. The main line uses a #10 ORB in, and a #12 ORB out port size, along with #10 ORB work ports. The valve is standard with a double 3 position spring centered configuration. However can be modified to detent with the purchase of a detent kit. Supplied complete with handles.

- 44-1530K2 x 3 position spring center.....655.00
- 44-1533K.....Detent kit85.00



GALTECH CONTROL VALVE (Q-95 SERIES)

This rotary spool valve has a maximum flow rate of 32 gpm and a maximum pressure rating of 3000psi. Rotary spool offers great speed control. The main line has a #12 ORB in port with a #12 ORB out. The work lines are #12 ORB. Valve comes complete with handle.

- 44-1540KRotary Spool.....675.00



GALTECH CONTROL VALVE (Q-75 SERIES)

This marine grade valve has a maximum flow rate of 22 gpm, with a maximum pressure rating of 3625 psi. The main line uses a #10 ORB in, and a #12 ORB out port size, along with #10 ORB work ports. Valve is available in 3 position detent, 3 position spring center, or 3 position spring center motor spool depending on your application. All models are supplied with handle.

- 44-1520K3 position detent465.00
- 44-1521K3 position spring415.00
- 44-1522K3 position spring motor spool415.00
- 44-1533K.....Detent kit85.00



GALTECH CONTROL VALVE (Q-45 SERIES)

This rotary spool valve has a maximum flow rate of 12 gpm and a maximum pressure rating of 3000psi. Great for smaller hydraulic system needs. Rotary spool offers great speed control. The main line has a #8 ORB in port with a #10 ORB out. The work lines are #8 ORB. Valve comes complete with handle.

- 44-1538KRotary Spool.....509.00



CROSS VALVES

This valve allows you to use the functions of a regular control valve, as well as a flow control valve, all in one unit. Maximum PSI 2500, 25 gpm, 3/4" Inlet & Outlet, with 1/2" work ports

- 44-126M3 Position Detent795.00

Replacement Parts

- 44-160M3 Position Detent Kit 1V029476.95
- 44-161M.....Spare Handle 1V170338.95
- 44-162MHandle Bracket 4Z430611.95
- 44-163MHandle Pin Kit 1V170113.95
- 44-164MSpring Centering Kit 1V122549.95
- 44-313MValve End Cap 1A0294P10.95
- 44-376MFlow Control Knob.....21.95
- 44-521MSeal Kit 2V0020.....68.95
- 44-522MPower Beyond Sleeve36.95
- 44-523MAllen Head Screw (Brk.).....1.59
- 44-524MAllen Head Screw(Detent).....2.05



FLOW CONTROL VALVE

Maximum flow rate 30 GPM. Maximum pressure 3000 psi. Output flow adjustable from 1 - 100%. Bypass flow can be used to power another circuit or returned to tank. Outlet flows are pressure compensated ensuring smooth controlled flow regardless of pressure changes. 3/4" ports.

- 44-125K.....199.00



HYDRAULIC SELECTOR VALVES

- 2 position single, 3/4" ports, max. pressure 3600 psi, 24 GPM.
- 44-435K.....3/4" Single 156.00
- 2 position single, 1" ports, max. pressure 3600 psi, 48 GPM.
- 44-436K..... 1" Single245.00
- 2 position double, 3/4" ports, max. pressure 3600 psi, 24 GPM.
- 44-437K.....3/4" Double295.00



HYDRAULIC POWER PACKS

A lightweight system powered by the renowned Honda 4-stroke gasoline engine. Proven reliability and endurance in the marine industry. Systems include Honda engine, Hydraulic pump/tank and return line filter. Units are completely assembled. Supplied with either stainless steel or marine aluminum tank and mount.



HONDA 5.5 HP – 5 GPM
Stainless steel hydraulic tank
 5.5 HP Honda GX160 engine, 5 gpm hydraulic gear pump. 3 gallon hydraulic tank.
 Approx. size: 20”H x 19”L x 16”W.
 Approx. dry weight: 55lbs.
 44-501AP.O.R.



HONDA 9 HP – 8 GPM
Stainless steel hydraulic tank
 9 HP Honda GX 270 engine, 8 gpm hydraulic gear pump. 5 gallon hydraulic tank.
 Approx. size: 23”H x 21”L x 18”W.
 Approx. dry weight: 85 lbs.
 44-379AP.O.R.



HONDA 13 HP – 11.3 GPM
Aluminum hydraulic tank
 13 HP Honda GX390 engine, 11.3 gpm hydraulic gear pump. 8 gallon hydraulic tank. Approx. size: 23”W x 26”L x 25”H. Approx. dry weight: 120 lbs.
 44-186KRecoil start, engine oil alert.....P.O.R.



HONDA GAS ENGINES
5.5 HP with 6:1 reduction (hauling lobster pots)
 44-458A6:1 reduction, GX160.....P.O.R.
 44-088KCapstan for Honda engine above.....P.O.R.

Straight drive (no reduction)
 44-540A5.5 HP, GX160P.O.R.
 44-377A9 HP, GX270.....P.O.R.
 44-187A13 HP, GX390.....P.O.R.



ALUMINUM GILLNET ROLLER
 44-533A20” drumP.O.R.



WIRE HEAD GURDY
 This stainless steel wire head gurdy comes complete with mounting plate, 17” wire head, hub, and hydraulic motor. Thousands of units sold. This gurdy comes in a number of set-ups ranging from 18’ speed boats up to 40’ longliners. See below specs for your gurdy requirements.

Ord. No.	Displ. Cu.in.	Type	Line Pull	Price
44-976A	24 cu.in.	Standard Duty	1000lbs	P.O.R.
44-788A	24 cu.in.	Heavy Duty	1200lbs	P.O.R.
44-643A	30 cu.in.	Extra Heavy Duty	1460lbs	P.O.R.

STAINLESS WIRE HEADS
 Reg. Wire Head 17”. Heavy duty s.s. wire heads built tough to withhold todays requirements.
 44-544AP.O.R.



STEEL BASE PLATES
Wire Head Gurdy
 44-946J1” Shaft.....P.O.R.
Heavy Duty Wire Head Gurdy
 44-947J1 1/4” Shaft.....P.O.R.



STEEL HUBS
Wire Head Gurdy
 44-548J1” Shaft.....P.O.R.
Heavy Duty Wire Head Gurdy
 44-582J1 1/4” Shaft.....P.O.R.

GRESEN™



GRESEN™



METARIS



GRESEN HYDRAULIC VANE PUMPS

Ord. No.	Mod.	Rot.	Max. PSI	GPM @		Inlet	Outlet	Shaft Size	Price
				1200 rpm					
44-114K	TB-12	cw	1500	11.0		1" NPT	3/4" NPT	3/4"	995.00
44-115K	TB-12	ccw	1500	11.0		1" NPT	3/4" NPT	3/4"	995.00
44-116K	TC-24	cw	1500	23.4		1 1/4" NPT	1" NPT	1"	1148.00
44-117K	TC-24	ccw	1500	23.4		1 1/4" NPT	1" NPT	1"	1148.00

METARIS HYDRAULIC GEAR PUMP

20 gpm. @ 1200 rpm, maximum pressure 2500 psi. 1" keyed shaft. This pump is commonly referred to as the "fish pump" and bolts directly to a 200 or 250 ft.lb. clutch, by using a SAE "A" 6-bolt round flange. Pump operates in either direction.

44-606K3000 Series.....749.00



ALUMINUM PUMP BRACKET

44-124Kfor TB Pumps.....	97.50
44-123Kfor TC Pumps.....	97.50



HYDRAULIC GEAR PUMPS

An exceptionally compact and lightweight pump for their capacity. Terrific for many low flow applications such as hydraulically driven washdown and water pumps and portable hydraulic power units. Simple, efficient pressure loaded design - few moving parts. Highly tolerant to fluid contamination and extremely reliable under cold weather operation.

ADJUSTABLE ALUMINUM PUMP BRACKET

44-339K.....410.00

Parker



Model D14

5.0 gpm @ 3600 rpm, max. psi 2500.

5/8" ORB inlet - 1/2" ORB outlet.

Shaft size 1/2". 4-bolt mounting. Clockwise rotation.

44-573K.....452.00

Parker



Model D22

7.9 gpm @ 3600 rpm, max. psi 2500.

5/8" ORB inlet - 1/2" ORB outlet.

Shaft size 1/2". SAE-A 2-bolt mounting. Clockwise rotation.

44-574K.....452.00



ADJUSTABLE STEEL PUMP BRACKET

44-628K.....299.00



PITTS BELT DRIVE ELECTRIC CLUTCH

Model H24V90 - 90 ft.lb.

Static torque rating of 90 ft. lbs. 6" dia., 2 groove pulley for 1/2" v-belts. 5000 rpm max., 4 amp draw. Designed to fit Gresen TB pumps.

12v. clutch for 3/4" keyed shaft & "A" 2 bolt style pump mount

44-128K.....#13233.....2785.00

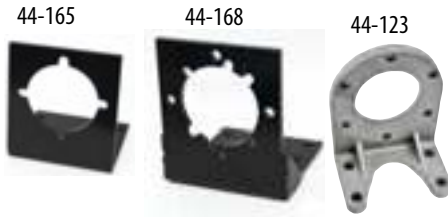

MOUNTING BRACKETS

For 90 Ft. Lbs. Clutch "TB" mount.

44-165K.....295.00

For 200/250' Lbs. Clutch "TC" & "B" mount direct drive.

44-168K.....149.00

For 200/250' Lbs. Clutch "TC" mount belt drive.

44-123K.....97.50



MOUNTING BRACKETS

For 450 & 1000 Ft. Lbs. Clutches

44-940K.....For "B" mount.....P.O.R.

44-939K.....For "C" mount.....P.O.R.

OGURA



250 FT. LBS. CLUTCHES

The OGURA clutch series offers both reliability and affordability. The new spring design makes this clutch bi-directional and can be converted from 1" bore to 3/4" bore, 7/8" keyed or splined drive by adding an insert. The 1" bore is double keyed for a quick fix in a damaged keyway situation.

Following the design of our extremely popular and reliable 250' lbs. "TC" mount clutch, Mercer's Marine introduces the same great clutch in a "B" mount configuration. You can now easily bolt the clutch to any "B" mount pump and bracket with 2 bolts for a very strong and quick installation. All fit standard 1" keyed shaft.

Belt Driven Model

44-740K....."TC" Mount (12V).....1615.00

44-1115K....."TC" Mount (24V).....1680.00

Direct Drive Model

44-754K....."TC" Mount (12V).....1605.00

44-166K....."TC" Mount (24V).....1669.00

44-1124K....."B" Mount (12V).....1680.00

44-1469K....."B" Mount (24V).....1760.00



CONVERSION INSERTS FOR 250 FT. LBS. CLUTCH

44-410K.....1" to 3/4" keyed insert.....P.O.R.

44-411K.....1" to 7/8" splined insert.....P.O.R.

44-412K.....1" to 7/8" keyed insert.....P.O.R.



DRIVELINES

Fits both Ogura and Pitts clutches.

Model 1310

44-169K.....fits 250 Ft. Lbs.599.00

Model 1410

44-941K.....fits 450 & 1000 Ft. Lbs.725.00

OGURA



450 FT. LBS. CLUTCHES

The OGURA 450 and 1000 Ft. Lbs. clutches have all the same advantages as the 250 Ft. lbs. clutch with the exception that it requires an insert (see below) to convert the 1 3/4" bore to your pump specifications, making it one of the most versatile clutches in the industry. All 450 & 1000 Ft. Lbs. clutches are direct drive.

450 Ft. Lbs. models

44-1116K.....12V.....P.O.R.

44-1117K.....24V.....P.O.R.



CONVERSION INSERTS FOR 450 & 1000 CLUTCHES

450 Ft. Lbs. Clutch

44-400K.....7/8" Splined.....P.O.R.

44-401K.....1" Keyed.....P.O.R.

44-402K.....1" Keyed (Permco pumps).....P.O.R.

44-403K.....1 1/4" Splined.....P.O.R.

44-404K.....1 1/4" Keyed.....P.O.R.

44-405K.....1 1/4" Keyed (Permco).....P.O.R.





HY SERIES CRIMP FITTINGS

MP style, male NPTF.

44-1094P1/4"H x 1/4" NPT4.60
44-871P3/8"H x 1/4" NPT6.95
44-295P3/8"H x 3/8" NPT4.95
44-178P1/2"H x 1/2" NPT5.95
44-872P1/2"H x 3/4" NPT17.50
44-179P3/4"H x 3/4" NPT8.50
44-180P1"H x 1" NPT13.50



HY SERIES CRIMP FITTING

HY series FJ style, swivel female 37°.

44-1093P1/4"H x 1/4" tube5.50
44-873P3/8"H x 1/4" tube11.95
44-296P3/8"H x 3/8" tube6.35
44-874P1/2"H x 3/8" tube9.50
44-181P1/2"H x 1/2" tube7.75
44-875P1/2"H x 5/8" tube7.95
44-876P1/2"H x 3/4" tube13.50
44-878P3/4"H x 5/8" tube28.50
44-182P3/4"H x 3/4" tube11.25
44-183P1"H x 1" tube17.95



HY SERIES CRIMP FITTING

FJ45T style, swivel female 37°.

44-860P3/8"H x 3/8" tube12.95
44-861P1/2"H x 1/2" tube18.45
44-862P1/2"H x 5/8" tube27.50
44-863P3/4"H x 3/4" tube26.95
44-864P1"H x 1" tube72.95



HY SERIES CRIMP FITTING

FJ90T Style, swivel, female 37°.

44-866P3/8"H x 3/8" tube11.50
44-867P1/2"H x 1/2" tube10.50
44-868P1/2"H x 5/8" tube18.95
44-869P3/4"H x 3/4" tube27.95
44-870P1"H x 1" tube39.95

HYDRAULIC FITTINGS



RE-USABLE FITTING

Rigid male NPTF.

44-218P1/2"H x 1/2" NPT39.95
---------	-----------------------	------------



RE-USABLE FITTING

Female Swivel JIC

44-221P1/2"H x 1/2" Tube42.95
44-222P3/4"H x 3/4" Tube93.95



QUICK DISCONNECT COUPLINGS

Allows for quick & easy connect & disconnect of hydraulic lines. Great for changing haulers to winches, etc. and continue to use the same control valve.

44-1365P1/4" Set24.95
44-577P3/8" Set26.95
44-188P1/2" Set26.95
44-189P3/4" Set49.95



60-TB ADAPTOR SWIVELS

Male ORB. to 45° NSPM swivel female.

44-366P 6-67.25
44-248P 8-88.95
44-249P 10-87.95
44-250P 10-1216.95
44-251P 12-1217.25
44-914P 16-1624.75



60-UB ADAPTOR SWIVELS

Male ORB. to 90° NSPM swivel female.

44-298P 6-64.65
44-244P 8-85.95
44-245P 10-86.95
44-246P 10-1213.95
44-247P 12-1210.25
44-915P 16-1616.50



60-SA SERIES ADAPTOR SWIVELS

NPTF male to NSPM swivel female.

44-880P1/4"NPT x 1/4"NPSM2.10
44-881P1/4"NPT x 3/8"NPSM4.25
44-882P3/8"NPT x 1/4"NPSM2.95
44-294P3/8"NPT x 3/8"NPSM2.40
44-883P3/8"NPT x 1/2"NPSM3.40
44-884P1/2"NPT x 3/8"NPSM3.40
44-224P1/2"NPT x 1/2"NPSM3.75
44-225P1/2"NPT x 3/4"NPSM6.95
44-226P3/4"NPT x 1/2"NPSM6.25
44-227P3/4"NPT x 3/4"NPSM5.10
44-885P1"NPT x 3/4"NPSM8.95
44-228P1"NPT x 1"NPSM7.65



60-SB ADAPTOR SWIVELS

Male ORB to NSPM. Swivel female.

44-293P 6-62.85
44-238P 8-83.10
44-239P 8-128.35
44-240P 10-84.10
44-241P 10-128.50
44-242P 12-126.50
44-243P 16-169.50



60-TA SERIES ADAPTOR SWIVELS

NPTF rigid male to NSPM swivel female.

44-367P3/8"NPT x 3/8"NPSM3.95
44-234P1/2"NPT x 1/2"NPSM4.95
44-886P1/2"NPT x 3/4"NPSM14.95
44-235P3/4"NPT x 1/2"NPSM15.95
44-236P3/4"NPT x 3/4"NPSM7.95
44-237P1"NPT x 1" NPSM15.50



60-UA SERIES ADAPTOR SWIVELS

NPTF male to NSPM swivel female.

44-292P3/8"NPT x 3/8"NPSM3.65
44-229P1/2"NPT x 1/2"NPSM4.75
44-230P1/2"NPT x 3/4"NPSM10.95
44-231P3/4"NPT x 1/2"NPSM7.60
44-232P3/4"NPT x 3/4"NPSM7.95
44-233P1"NPT x 1" NPSM12.95



25-UA SERIES ADAPTORS

NPTF male pipe elbow 90°.

44-380P.....	3/8" NPT x 3/8" NPT	2.65
44-261P.....	1/2" NPT x 1/2" NPT	4.25
44-262P.....	3/4" NPT x 3/4" NPT	6.20
44-263P.....	1" NPT x 1" NPT	15.75



882-FS SERIES ADAPTORS

NPTF Rigid female to 37° swivel female.

44-897P.....	3/8" NPTF x 3/8" NPSM	4.95
44-898P.....	1/2" NPTF x 1/2" NPSM	8.50
44-899P.....	3/4" NPTF x 3/4" NPSM	8.95



848-FS ADAPTORS

Straight male 37° flared to male NPTF.

44-904P.....	1/4" tube x 1/4" NPT	1.09
44-905P.....	3/8" tube x 1/4" NPT	1.40
44-297P.....	3/8" tube x 3/8" NPT	1.40
44-906P.....	3/8" tube x 1/2" NPT	1.95
44-907P.....	1/2" tube x 3/8" NPT	1.85
44-267P.....	1/2" tube x 1/2" NPT	1.95
44-268P.....	1/2" tube x 3/4" NPT	2.95
44-908P.....	5/8" tube x 1/2" NPT	2.20
44-909P.....	5/8" tube x 3/4" NPT	3.95
44-269P.....	3/4" tube x 1/2" NPT	3.45
44-270P.....	3/4" tube x 3/4" NPT	2.99
44-271P.....	3/4" tube x 1" NPT	5.50
44-272P.....	1" tube x 3/4" NPT	5.25
44-273P.....	1" tube x 1" NPT	4.75



24-SA SERIES ADAPTORS

Male pipe nipple.

44-369P.....	3/8" NPT x 3/8" NPT	1.50
44-255P.....	1/2" NPT x 1/2" NPT	1.95
44-256P.....	3/4" NPT x 1/2" NPT	2.95
44-257P.....	3/4" NPT x 3/4" NPT	3.25
44-258P.....	1" NPT x 1" NPT	4.65



849-FSO ADAPTORS

37° Flare Male x 90° Male ORB

44-1396P.....	6-6	2.50
44-1397P.....	8-8	3.45
44-1398P.....	8-10	4.95
44-1399P.....	12-10	7.85
44-1400P.....	12-12	7.15
44-1401P.....	16-16	12.35

HYDRAULIC FITTINGS



25-VJ ADAPTORS

NPTF female pipe tee.

44-889P.....	3 x 3/8" NPT	5.65
44-890P.....	3 x 1/2" NPT	7.75
44-891P.....	3 x 3/4" NPT	11.50
44-892P.....	3 x 1" NPT	18.75



24-ST ADAPTORS

Hex head plug.

44-900P.....	3/8"	0.70
44-901P.....	1/2"	0.99
44-902P.....	3/4"	2.20
44-903P.....	1"	3.95



849-FS ADAPTORS

37° flared male to NPTF male.

44-299P.....	3/8" tube x 3/8" NPT	2.65
44-276P.....	1/2" tube x 1/2" NPT	3.55
44-277P.....	1/2" tube x 3/4" NPT	6.15
44-278P.....	3/4" tube x 1/2" NPT	7.15
44-280P.....	3/4" tube x 3/4" NPT	5.75
44-281P.....	3/4" tube x 1" NPT	11.25
44-282P.....	1" tube x 3/4" NPT	9.95
44-283P.....	1" tube x 1" NPT	8.75

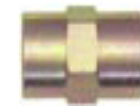

24-SJ SERIES ADAPTORS

NPTF female union.

44-383P.....	3/8"	1.75
44-252P.....	1/2"	2.95
44-253P.....	3/4"	4.25
44-254P.....	1"	7.25



24-SB SERIES ADAPTORS

NPTF male to NPTF female bushing.

44-887P.....	3/8" NPT x 1/4" NPT	1.35
44-381P.....	1/2" NPT x 3/8" NPT	1.75
44-259P.....	3/4" NPT x 1/2" NPT	2.75
44-260P.....	1" NPT x 3/4" NPT	3.95
44-966P.....	1 1/4" NPT x 1" NPT	6.25



25-VC ADAPTORS

NPTF male-female pipe tee.

44-893P.....	3/8" NPT Int x 3/8" NPT Ext	6.25
44-894P.....	1/2" NPT Int x 1/2" NPT Ext	9.95
44-895P.....	3/4" NPT Int x 3/4" NPT Ext	11.95
44-896P.....	1" NPT Int x 1" NPT Ext	34.95



842-FS ADAPTORS

37° male union.

44-384P.....	3/8"	1.35
44-264P.....	1/2"	1.85
44-934P.....	5/8"	2.60
44-265P.....	3/4"	3.40
44-266P.....	1"	5.50



844-FS ADAPTORS

Tube tee.

44-910P.....	3 x 3/8" tube	2.85
44-911P.....	3 x 1/2" tube	4.35
44-912P.....	3 x 3/4" tube	8.95
44-913P.....	3 x 1" tube	24.95



848-FSO ADAPTORS

Male O.R.B. connector.

44-368P.....	6-6	1.20
44-284P.....	8-8	1.65
44-581P.....	8-10	2.10
44-580P.....	8-12	4.10
44-285P.....	10-8	2.35
44-286P.....	10-12	3.75
44-288P.....	12-8	4.95
44-378P.....	12-10	5.10
44-287P.....	12-12	3.20
44-289P.....	16-16	4.75



720-FSO ADAPTORS

O-ring Boss to female NPT.

44-382P.....	8-6	2.25
44-916P.....	8-8	4.25
44-917P.....	10-8	3.95
44-918P.....	10-12	6.95
44-290P.....	12-8	6.25
44-291P.....	16-12	8.50

721-FSO O. R. B. PLUG

44-919P.....	6	0.85
44-920P.....	8	1.15
44-921P.....	10	1.55
44-922P.....	12	2.35



S-3735 REDUCERS

SAE 37° flare adaptors

44-385P.....	8-6.....	2.10
44-274P.....	12-8.....	4.50
44-275P.....	16-12.....	7.95



S-3756 CAP NUTS

Cap steel nut 37° flare adaptor.

44-1100P.....	3/8".....	0.85
44-1101P.....	1/2".....	1.10
44-1102P.....	3/4".....	1.95
44-1103P.....	1".....	2.95



S-3758 TUBE PLUG

SAE 37° flare adaptor.

44-1110P.....	3/8".....	0.85
44-1111P.....	1/2".....	1.15
44-1112P.....	3/4".....	2.15
44-1113P.....	1".....	3.85



TRANSMISSION OIL COOLER

2" Diameter, 12" body length, 15" overall. All copper and brass construction. 1/2" NPT oil nuts.

44-562K.....	1" hose x 1/2" NPT.....	429.00
44-563K.....	1 1/4" hose x 1/2" NPT.....	429.00



HYDRAULIC OIL COOLER (HIGH PRESSURE)

Constructed of high quality brass and copper. 3" dia. body x 12" body length. Rated up to 375 psi. 1" NPT oil hose fittings, 1 1/2" water hose fittings. Simply install on a hydraulic return line and to suitable water supply.

44-1068M.....	High pressure.....	795.00
---------------	--------------------	--------



HIGH PRESSURE HYDRAULIC HOSE

44-363P.....	3/8" 4000 PSI.....	3.29/ft.
44-170P.....	1/2" 3500 PSI.....	3.49/ft.
44-171P.....	3/4" 2250 PSI.....	4.95/ft.
44-172P.....	1" 2000 PSI.....	7.85/ft.



HYDRAULIC RETURN LINE

Multi purpose hose used for oil return.

38-668R.....	5/8" 250 PSI.....	4.45
38-669R.....	3/4" 250 PSI.....	4.95
38-670R.....	1" 200 PSI.....	5.60
38-671R.....	1 1/4" 200 PSI.....	10.95
38-672R.....	1 1/2" 200 PSI.....	13.50
38-673R.....	2" 200 PSI.....	16.95



HYDRAULIC IN-LINE FILTERS

Model FSP1 - 15 gpm, 3/4" ports, 10 micron element.

44-347K.....	Complete Filter.....	49.95
44-348K.....	Element Only.....	19.95

Model FSP2 - 45 gpm, 1 1/4" ports, 10 micron element.

44-349K.....	Complete Filter.....	119.95
44-350K.....	Element Only.....	56.95



PETROWRAP ANTI-CORROSION TAPE

Petrowrap Tape has been developed for long term protection of metal surfaces that are underground, underwater, or exposed - even in the most severe environments. It consists of a cold applied system of petrolatum-based PetroWrap Anti-Corrosion Tape, PetroWrap Primer, and, where contouring is necessary, PetroWrap Mastic. PetroWrap adheres to surfaces without heating, even on damp and/or indifferently prepared areas. 50mm wide x 10m

44-1072K.....	High pressure.....	11.95
---------------	--------------------	-------



HYDRAULIC TANKS

Heavy duty construction, complete with 1 1/4" suction & return ports. Complete with breather cap and 3/8" drain plug.

17"L x 5"W x 17"H		
44-337K.....	Stainless steel, 6 gal.....	660.00
20"L x 8 1/2"W x 20"H		
44-338K.....	Stainless steel, 12 gal.....	789.00
22 1/4"L x 12 1/2"W x 21 1/4"H		
44-713K.....	Aluminum tank, 24 gal.....	917.00

Replacement breather cap		
44-594K.....	21.95



Visit us online at www.mercersmarine.com

- Updated Pricing
- Updated Products
- Available 24/7



SUPERDAN ROPE

Excellent anti-abrasion properties contribute to a prolonged working life. High ultra-violet light resistance. A cost effective super strength rope. A multi purpose rope ideal for general industrial & commercial fishing applications. An excellent rope for deep sea crabpot use. We sell genuine "SUPERDAN ROPE" from the worlds largest rope factory. Quality assured! **Price On Request.**

Ord.No.	Size	Approx. weight	Approx. Break Strength
Green			
66-950A	3/16"	13.14 lbs/1800 ft.	1000 lbs.
66-951A	1/4"	14.76 lbs/1200 ft.	1670 lbs.
66-952A	9/32"	21.6 lbs/1200 ft.	2420 lbs.
66-953A	5/16"	26.64 lbs/1200 ft.	3170 lbs.
66-954A	3/8"	33.6 lbs/1200 ft.	3920 lbs.
66-955A	7/16"	40 lbs/1200 ft.	4870 lbs.
66-956A	1/2"	58.56 lbs/1200 ft.	6870 lbs.
66-957A	9/16"	75 lbs/1200 ft.	9320 lbs.
66-958A	5/8"	102 lbs/1200 ft.	11500 lbs.
66-959A	3/4"	65.4 lbs/600 ft.	14600 lbs.
66-960A	1"	115.2 lbs/600 ft.	24300 lbs.
66-962A	1 1/4"	177.6 lbs/600 ft.	34600 lbs.
66-964A	1 1/2"	259.8 lbs/600 ft.	48500 lbs.
66-969A	2"	500.4 lbs/600 ft.	87800 lbs.

Yellow/Green Tracer

66-940A	9/32"	21.6 lbs/1200 ft.	2420 lbs.
66-941A	5/16"	26.64 lbs/1200 ft.	3170 lbs.
66-942A	3/8"	33.6 lbs/1200 ft.	3920 lbs.



POLYROPE

Polyrope on Spools

66-442J	3/16" x 2125'	40.95
66-443J	1/4" x 1300'	40.95
66-445J	5/16" x 975'	40.95
66-446J	3/8" x 630'	40.95
66-448J	1/2" x 335'	40.95
66-449J	5/8" x 200'	40.95

Polyrope by the Foot

66-416M	3/16"	0.03/ft.
66-417M	1/4"	0.04/ft.
66-418M	5/16"	0.05/ft.
66-419M	3/8"	0.08/ft.
66-420M	1/2"	0.15/ft.
66-421M	5/8"	0.25/ft.

DOUBLE BRAIDED NYLON ROPE BY THE COIL

Price on request.

Ord.No.	Size	Approx. wt./1200ft.	Approx. Break Strength
66-361A	1/4"	20 lbs.	2242 lbs.
66-362A	5/16"	32lbs.	3315 lbs.
66-363A	3/8"	44 lbs.	4777 lbs.
66-364A	1/2"	76 lbs.	8287 lbs.
66-365A	5/8"	144 lbs.	14820 lbs.
66-366A	3/4"	192 lbs.	18622 lbs.
66-367A	1"	156 lbs.x 600'	32760 lbs.

DOUBLE BRAIDED ROPE BY THE FOOT

66-126M	1/4"	0.35/ft.	66-129M	1/2"	1.09/ft.
66-127M	5/16"	0.49/ft.	66-131M	5/8"	1.75/ft.
66-128M	3/8"	0.75/ft.	66-132M	3/4"	2.40/ft.



3-STRAND TWISTED NYLON ROPE BY THE FOOT.

Ord.No.	Size	Approx. Break Strength	Price per ft.
66-428M	1/4"	1575 lbs.	0.12/ft.
66-429M	5/16"	2995 bs.	0.19/ft.
66-430M	3/8"	4275 lbs.	0.29/ft.
66-431M	1/2"	5850 lbs.	0.49/ft.
66-432M	5/8"	10125 lbs.	0.73/ft.
66-433M	3/4"	13500 lbs.	1.05/ft.





XLE-PERFORMER ROPE

XLE is made from the highest quality polyester yarns with marine finish on both core and cover. The balanced core to cover construction insures that XLE will remain easy to handle and splice while offering maximum abrasion resistance. Color fast cover yarns are solution dyed Firebrite 2000 polyester available in red, blue and black. This strong, low stretch double braid is ideal for all running rigging applications on performance cruisers and racing boats. 100% polyester double braid. **Approx. 600 feet per coil.**

Order No.	Size	Main Colour - Tracer Colour	Breaking Strength	Price/ft
66-1150M	5/16"	White - (Red x 2)	3500 lbs	0.60
66-1151M	5/16"	White - (Blue x 2)	3500 lbs	0.60
66-1156M	5/16"	Red - (White x 3)	3500 lbs	0.69
66-1157M	5/16"	Blue - (White x 3)	3500 lbs	0.69
66-1159M	5/16"	Black - (White x 3)	3500 lbs	0.69
66-1160M	3/8"	White - (Red x 2)	4900 lbs	0.75
66-1161M	3/8"	White - (Blue x 2)	4900 lbs	0.75
66-1166M	3/8"	Red - (White x 3)	4900 lbs	0.89
66-1167M	3/8"	Blue - (White x 3)	4900 lbs	0.89
66-1169M	3/8"	Black - (White x 3)	4900 lbs	0.89
66-1170M	7/16"	White - (Red x 2)	6200 lbs	0.89
66-1171M	7/16"	White - (Blue x 2)	6200 lbs	0.89
66-1175M	7/16"	Red - (White x 3)	6200 lbs	1.05
66-1176M	7/16"	Blue - (White x 3)	6200 lbs	1.05
66-1178M	7/16"	Black - (White x 3)	6200 lbs	1.05
66-1180M	1/2"	White - (Red x 2)	8500 lbs	1.09
66-1181M	1/2"	White - (Blue x 2)	8500 lbs	1.09
66-1186M	1/2"	Red - (White x 3)	8500 lbs	1.35
66-1187M	1/2"	Blue - (White x 3)	8500 lbs	1.35
66-1189M	1/2"	Black - (White x 3)	8500 lbs	1.35



SPECTEC-12 SYNTHETIC ROPE

SPECTEC-12™ is a hollow braided 12-strand rope using 100% Spectra fiber. It is designed with single ply construction. Spectec-12 yields one of the highest strength to weight ratios available in a synthetic rope. It comes standard with a urethane coating that provides additional abrasion resistance while remaining easy to handle and splice. SPECTEC-12™ has a Gravity of 0.98, Very High Strength, Low Elongation, Easy Handling, Fully Spliceable. SPECTEC-12™ is commonly used for Wire Rope Replacement, Mooring Lines, Winch Lines, Pulling Lines and Rigging Lines.

Ord.No.	Size	Approx. Weight lbs/100 ft	Approx. Break Strength	Price/ft
66-890K	1/8"	0.53	1600 lbs	0.52
66-891K	3/16"	1.04	3200 lbs	1.05
66-892K	1/4"	1.7	8800 lbs	1.50
66-893K	5/16"	2.9	14520 lbs	2.29
66-894K	3/8"	3.8	21120 lbs	2.79
66-895K	7/16"	4.3	16500 lbs	4.39
66-896K	1/2"	6.4	27500 lbs	4.95



BRAIDED CORKLINE

First quality, Canadian made corkline. 1/4" x 56 fathom spools. Used for headrope on herring, mackerel and char nets. Also good for clothesline rope.

66-138K.....43.95



LIFEBUOY SAFETY ROPE

Floating braided 5/16" polypropylene rope. Yellow with colored tracer. Used on lifebuoys, securing fenders and general purpose applications. 600 ft per spool.

66-534R 0.35 per ft.



WAXED SAIL TWINE & SAIL PALM

66-862K 1/4 lb spool.....28.95
 46-627P Right Hand Sail Palm25.95
 46-628P Left Hand Sail Palm.....25.95

SAIL NEEDLES

46-623P.....#11 (3 1/2" L)2.50
 46-625P.....#14 (2 3/4"L)2.50
 46-626P.....#16 (2 3/8"L)2.50



PREMIUM DOUBLE BRAIDED NYLON DOCKLINE

These light- and heat-stabilized lines are made from strong, multifilament nylon fiber that can absorb sudden shock loads without breaking. These dock lines offer greater wet strength and abrasion-resistance than other nylons, and are spliced for added strength. Resistant to UV light, rot, oil, gasoline, grease, marine growth, mold, mildew, and most chemicals.

Order No.	Size	Colour	Price
66-1300P	3/8" X 15 ft	White	19.95
66-1301P	3/8" X 20 ft	White	21.95
66-1302P	3/8" X 25 ft	White	26.95
66-1303P	1/2" X 20 ft	White	31.95
66-1304P	1/2" X 25 ft	White	36.95
66-1324P	3/8" X 15 ft	Black	21.95
66-1325P	3/8" X 20 ft	Black	26.95
66-1326P	3/8" X 25 ft	Black	28.95
66-1327P	1/2" X 20 ft	Black	34.95
66-1328P	1/2" X 25 ft	Black	39.95
66-1335P	3/8" X 15 ft	Gold/White	19.95
66-1336P	3/8" X 20 ft	Gold/White	22.95
66-1337P	3/8" X 25 ft	Gold/White	26.95
66-1338P	1/2" X 20 ft	Gold/White	33.95
66-1339P	1/2" X 25 ft	Gold/White	38.95

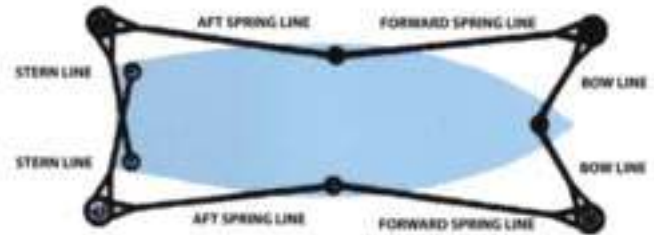

PREMIUM 3-STRAND TWISTED NYLON DOCKLINE

Three strand twisted nylon spliced, one end. Extremely strong rope designed to absorb sudden shock loads. Very good resistance to abrasion, rot, oils, gasoline and marine growth.

Order No.	Size	Colour	Price
66-1345P	3/8" X 10 ft	White	12.95
66-1346P	3/8" X 15 ft	White	13.95
66-1347P	1/2" X 15 ft	White	24.95
66-1348P	1/2" X 20 ft	White	26.95
66-1349P	1/2" X 25 ft	White	30.95





BRAIDED POLY TWINES

Supplied in 2 lb. balls.

66-829M.....1.5 mm (Orange)	P.O.R
66-830M.....1.75 mm (Orange)	P.O.R
66-831M.....2.0 mm (Orange)	P.O.R
66-832M.....2.5 mm (Orange)	P.O.R
66-833M.....3.0 mm (Orange)	P.O.R
66-834M.....4.0 mm (Orange)	P.O.R
66-836M.....5.0 mm (Orange)	P.O.R
66-838M.....6.0 mm (Orange)	P.O.R
66-840M.....1.5 mm (Green)	P.O.R
66-841M.....1.75 mm (Green).....	P.O.R
66-842M.....2.0 mm (Green)	P.O.R
66-843M.....2.5 mm (Green)	P.O.R
66-844M.....3.0 mm (Green)	P.O.R
66-845M.....4.0 mm (Green)	P.O.R
66-847M.....5.0 mm (Green)	P.O.R
66-849M.....6.0 mm (Green)	P.O.R
66-852M.....1.75 mm (Black)	P.O.R
66-853M.....3 mm (Blue)	P.O.R
66-854M.....4 mm (Blue)	P.O.R

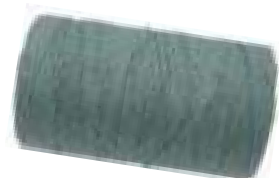

SPUN POLYESTER HANGING TWINES

Supplied in 1 lb. balls. Green

66-800M.....#10's /18	P.O.R
-----------------------------	-------



BROWNELL "HT" TWINES

This twine holds the knot you tie in it. Once tied, it will not tighten or loosen due to its unique bonding agent, which will not wash out. C-1 is the best twine available for hanging most types of fish nets, in particular monofilament gill and shrimp nets. It is suitable for use with polyethylene netting. The bonding gives the twine very high abrasion resistance. Non slip, heat treat coated. Supplied in 1 lb. balls.

66-879M.....#15 (brown)	P.O.R
66-880M.....#18 (brown)	P.O.R
66-882M.....#15 (green)	P.O.R
66-883M.....#18 (green)	P.O.R
66-885M.....#15 (white)	P.O.R
66-886M.....#18 (white)	P.O.R



TWISTED POLY TWINE

Supplied in 2 lb. balls.

66-824M.....#15 (orange)	P.O.R
66-825M.....#18 (orange)	P.O.R
66-827M.....#15 (green).....	P.O.R
66-828M.....#18 (green)	P.O.R



BRAIDED NYLON TWINES

Supplied in 2 lb. balls.

66-816M.....2.0 mm (white)	P.O.R
66-817M.....2.5 mm (white)	P.O.R
66-818M.....3.0 mm (white)	P.O.R
66-819M.....4.0 mm (white)	P.O.R
66-820M.....5.0 mm (white)	P.O.R
66-821M.....6.0 mm (white)	P.O.R



BRAIDED NYLON TWINES

Supplied in 1 lb. balls.

66-809M.....#12 (White)	P.O.R
66-810M.....#15 (White)	P.O.R
66-811M.....#18 (White)	P.O.R
66-812M.....#21 (White)	P.O.R
66-813M.....#24 (White)	P.O.R

66-802M.....#12 (Gold)	P.O.R
66-803M.....#15 (Gold)	P.O.R
66-804M.....#18 (Gold)	P.O.R
66-805M.....#21 (Gold)	P.O.R
66-806M.....#24 (Gold)	P.O.R



BIODEGRADABLE COTTON CRAB POT TWINE

Supplied in 1 lb. balls.

66-859M.....#96 BIO-DIG.....	P.O.R
------------------------------	-------



TARRED BRAIDED NYLON TWINE

Supplied in 2 lb. balls. Black.

66-873M.....#21	P.O.R
66-874M.....#24	P.O.R



MONO MENDING TWINE

Supplied in 1 lb. balls. Green.

66-861M.....#14	P.O.R
-----------------------	-------



BRAIDED NYLON MARKING TWINE #21

Supplied in 1 lb. spools. Commonly used for marking Lobster rope 3/8" and under.

Solid Colours

66-1520M.....#21 (Red).....	P.O.R
66-1521M.....#21 (Yellow).....	P.O.R
66-1522M.....#21 (Orange).....	P.O.R
66-1523M.....#21 (Brown).....	P.O.R
66-1524M.....#21 (Black).....	P.O.R
66-1525M.....#21 (Blue).....	P.O.R
66-1526M.....#21 (Green).....	P.O.R
66-1527M.....#21 (Grey).....	P.O.R
66-1529M.....#21 (Pink).....	P.O.R
66-1530M.....#21 (Purple).....	P.O.R

Mixed Colours

66-1540M.....2.5mm (Yellow/Black).....	P.O.R
66-1541M.....2.5mm (Black/White).....	P.O.R
66-1542M.....2.5mm (Red/White).....	P.O.R



TARRED NYLON MENDING TWINES

Black twisted. Supplied in 1 lb. balls.

66-870M.....210 / 6.....	P.O.R
66-871M.....210 / 9.....	P.O.R
66-872M.....210 / 12.....	P.O.R



TARRED POLYESTER TWINE

Black "Trapolin" mending. Supplied in 1 lb. balls.

66-867M.....1000D / 6.....	P.O.R
66-868M.....1000D / 9.....	P.O.R
66-869M.....1000D / 12.....	P.O.R

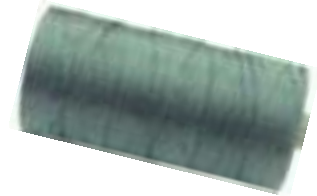

TWISTED NYLON MENDING TWINES

Supplied in 1 lb. balls. Green.

66-863M.....210 / 9.....	P.O.R
66-864M.....210 / 12.....	P.O.R
66-865M.....210 / 15.....	P.O.R
66-866M.....210 / 18.....	P.O.R



**Shop or Browse
Online 24/7
at
mercersmarine.com**



BRAIDED POLY MARKING TWINES 2.5MM

Supplied in 2 lb spools. Commonly used for marking Crab and Gill Net rope 7/16" and larger.

Solid Colours

66-1500M.....2.5mm (Red).....	P.O.R
66-1501M.....2.5mm (Yellow).....	P.O.R
66-1503M.....2.5mm (Brown).....	P.O.R
66-1504M.....2.5mm (Black).....	P.O.R
66-1505M.....2.5mm (Blue).....	P.O.R
66-1508M.....2.5mm (Grey).....	P.O.R
66-1509M.....2.5mm (White).....	P.O.R
66-1510M.....2.5mm (Pink).....	P.O.R
66-1511M.....2.5mm (Purple).....	P.O.R

Mixed Colours

66-1512M.....2.5mm (Black/White).....	P.O.R
66-1513M.....2.5mm (Yellow/Black).....	P.O.R
66-1514M.....2.5mm (Black/Blue).....	P.O.R
66-1515M.....2.5mm (Yellow/Green).....	P.O.R
66-1516M.....2.5mm (Red/White).....	P.O.R
66-1517M.....2.5mm (Pink/Blue).....	P.O.R
66-1518M.....2.5mm (Red/Green).....	P.O.R



For current prices on nets and leadrope, check our website at www.mercersmarine.com



HERRING AND MACKEREL WEBS

210/9 Nylon twine, Dark Green. All 56yds. Long.

HERRING MESH SIZES (KNOTTED)

- 66-415A2 1/8" Mesh x 150 Mesh DeepP.O.R
- 66-410A2 1/4" Mesh x 150 Mesh DeepP.O.R
- 66-411A2 1/2" Mesh x 150 Mesh DeepP.O.R
- 66-412A2 5/8" Mesh x 150 Mesh DeepP.O.R
- 66-413A2 3/4" Mesh x 150 Mesh DeepP.O.R
- 66-414A2 7/8" Mesh x 150 Mesh DeepP.O.R

HERRING MESH SIZES (KNOTLESS)

- 66-552A2 1/4" Mesh x 150 Mesh DeepP.O.R
- 66-555A2 1/2" Mesh x 150 Mesh DeepP.O.R
- 66-556A2 5/8" Mesh x 150 Mesh DeepP.O.R
- 66-557A2 5/8" Mesh x 200 Mesh DeepP.O.R

MACKEREL MESH SIZES(KNOTTED)

- 66-069A3" Mesh x 150 Mesh DeepP.O.R
- 66-070A3 1/4" Mesh x 150 Mesh DeepP.O.R

MACKEREL MESH SIZES (KNOTLESS)

- 66-466A3" Mesh x 150 Mesh DeepP.O.R
- 66-467A3 1/4" Mesh x 150 Mesh DeepP.O.R



TWISTED NYLON WEBS

Most commonly used for Trout and Arctic Char. 210/9 nylon twine x 56 yds. Color: Green. Check with D.F.O. for allowable catch species and legal mesh size in your area.

- 66-061A 3" Mesh x 50 Mesh DeepP.O.R
- 66-062A 3 1/4" Mesh x 50 Mesh DeepP.O.R
- 66-063A 3 1/2" Mesh x 50 Mesh DeepP.O.R
- 66-064A 4" Mesh x 50 Mesh DeepP.O.R
- 66-610A 4 1/2" x 50 Mesh DeepP.O.R
- 66-724A 5" x 25 Mesh DeepP.O.R



LARGE GILLNET BAGS WITH DRAWSTRING

Extra strong poly woven bags for hung nets, etc.

- Large Bags (52" x 30"W)
- 66-238A2.19 ea.



MONO GILLNETS

We stock only the best quality soft webs from some of the world's best manufacturers. All webs are 100 fathoms long.

Ord. No.	Size	Price
66-043A	#14 x 5 1/2" x 25MD	P.O.R.
66-045A	#14 x 6" x 25MD	P.O.R.
66-046A	#14 x 6 1/2" x 25MD	P.O.R.
66-047A	#14 x 7" x 25MD	P.O.R.
66-048A	#14 x 7 1/2" x 25MD	P.O.R.
66-049A	#14 x 8" x 25MD	P.O.R.
66-543A	#14 x 9" x 25MD	P.O.R.

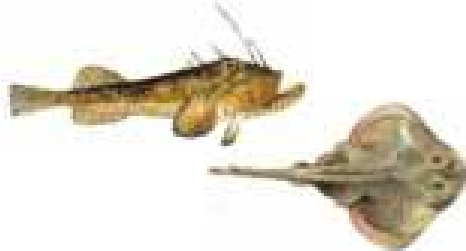

MONK & SKATE FISH NETS

#16 Mono Twine x 12" Mesh x 14 Mesh Deep x 150 Fathoms. Color: Green.

- 66-391AP.O.R.



LUMP FISH NETS

#14 x 10 1/2" mesh x 100 Fms.

- 66-059A10 Mesh DeepP.O.R
- 66-637A15 Mesh DeepP.O.R



GILLNET BAGS

Extra strong poly woven bags for hung nets, etc.

- (45" x 30"W)
- 66-237A1.39 ea.



LEADROPE (BRAIDED)

- 66-161A#40 (Approx. 20lb/50 Fms.)P.O.R.
 - 66-162A#27 (Approx. 27lb/50 Fms.)P.O.R.
 - 66-163A#33 (Approx. 33lb/50 Fms.)P.O.R.
 - 66-218A#85 (Approx. 42lb/50 Fms.)P.O.R.
- Double jacket bull braid**
- 66-219A#85 (Approx. 45lb/50 Fms.)P.O.R.
- (Not sold less than 50 fathom lengths.)



TUBULAR SPLICING FIDS FOR BRAIDED ROPE

- 46-930Pfor 1/4" rope9.50
- 46-932Pfor 3/8" rope10.95
- 46-933Pfor 1/2" rope12.75
- 46-934Pfor 5/8" rope15.95
- 46-935Pfor 3/4" rope19.50
- 46-936Pfor 7/8" rope23.95
- 46-937Pfor 1" rope30.95

Fid Pusher

- 46-938P1/4" to 1/2"6.40
- 46-939P5/8" to 1"10.75

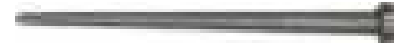

STAINLESS STEEL MARLIN SPIKES

- 46-891P6"16.25
- 46-892P8"23.95
- 46-893P10"27.95
- 46-894P12"34.95
- 46-895P14"42.95
- 46-896P16"67.95
- 46-897P18"74.95
- 46-898P20"87.95



SPLICING FIDS

Stainless steel with wooden handle.

- 46-589R13/16" x 6 11/16"7.95
- 46-590R1 1/4" x 11"9.95
- 46-591R1 7/8" x 15"28.95



NET NEEDLES

Type "A" Flat Style

- 66-242P1 1/4" x 10"2.39

Type "B" Norwegian Style

- 66-243P5/16" x 6" (8.5mm)5.49
- 66-244P3/8" x 7" (10mm)7.25
- 66-245P1/2" x 8" (14mm)8.25
- 66-246P5/8" x 8" (16mm)8.75
- 66-440P3/4" x 10" (20mm)11.95
- 66-441P1 3/8" x 11" (33mm)15.50

Commercial Fishing Products

COMMERCIAL FISHING GEAR

Prices are subject to change. Check our website for up to date prices. www.mercersmarine.com



#1 STYRO-FLOAT
66-080J.....31 lbs Buoyancy.....P.O.R

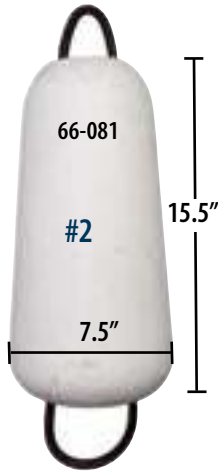

#2 STYRO-FLOAT
Extra Heavy Wire
66-081J.....19 lbs Buoyancy.....P.O.R

#3 STYRO-FLOAT
Extra Heavy Wire
66-082J.....19 lbs Buoyancy.....P.O.R



#5 STYRO-BOBBER
66-084J.....14 lbs Buoyancy.....P.O.R



#6 STYRO-BOBBER
66-085J.....7.5 lbs Buoyancy.....P.O.R

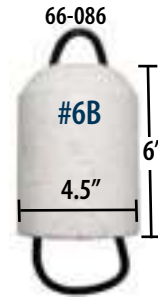

#6B STYRO-BOBBER
66-086J.....3 lbs Buoyancy.....P.O.R



#4 STYRO-FLOAT
66-083J.....13 lbs Buoyancy.....P.O.R



#12 STYRO-FLOAT
Heavy Wire Loops
66-095J.....65 lbs Buoyancy.....P.O.R



#8 STYRO-FLOAT (STAFF)
Centre hole 1 1/4"
66-088J.....26 lbs Buoyancy.....P.O.R



#10 STYRO-FLOAT
Centre hole 1 1/4"
66-093J.....10 lbs Buoyancy.....P.O.R



#9 STYRO-FLOAT
Centre hole 2"
66-092J.....28 lbs Buoyancy.....P.O.R

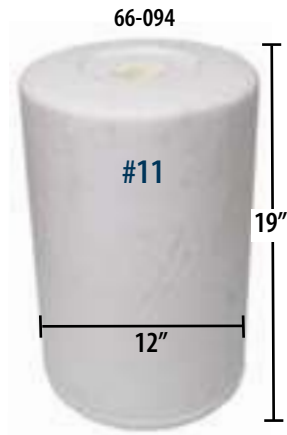

#11 STYRO-FLOAT
Centre hole 2 1/8"
66-094J.....65 lbs Buoyancy.....P.O.R



SINGLE EYE POLY BUOYS

The original POLYFORM™ all purpose buoy/"all round" fender with its well-known blue, rib-reinforced ropehold. Produced from the best marine grade Vinyl material by use of Provinor's in-house developed Welcotec moulding technology. The specially designed, solid and multiple rib-reinforced ropeholds guarantee the highest breaking strength available. POLYFORM™ buoys/fenders are designed to stand up to the most demanding use in commercial fishing, aquaculture and for general marking and floatation applications and they are a "must" for the protection of larger recreational crafts and yachts.

Red Colour

Ord. #	Size	Dia.	Price
66-191K	20"	6"	13.95
66-192K	30"	9"	29.95
66-193K	40"	12"	37.50
66-194K	50"	16"	52.95
66-195K	60"	19"	73.95
66-196K	75"	24"	101.95
66-357K	100"	32"	243.95

White Colour

Ord. #	Size	Dia.	Price
66-261K	50"	16"	52.95
66-262K	60"	19"	73.95
66-263K	75"	24"	101.95



ALUMINUM RADAR REFLECTOR

POLE MOUNT TYPE

18" x 18". Used extensively by fishers on staff buoys.

66-231K	23.50
---------	-------



LOW DRAG BUOY

This bullet shaped buoy is designed to reduce drag. Under some conditions, the drag can be reduced by up to 80% compared to spherical buoys. Designed as heavy-duty buoys for offshore environments and used by commercial fisherman.

HL-1 BUOY 18.5" Length x 9" Dia.

66-324K	Red	44.50
---------	-----	-------

HL-2 BUOY 24.4" Length x 11.8" Dia.

66-320K	Red	65.95
---------	-----	-------

HL-3 BUOY 29.3" Length x 13.8" Dia.

66-203K	Red	84.95
---------	-----	-------

66-211K	White	84.95
---------	-------	-------

66-213K	Yellow	84.95
---------	--------	-------

HL-4 BUOY 37.4" Length x 15.7" Dia.

66-314K	Red	121.50
---------	-----	--------



STAFF BUOYS

Ord. #	Size	Dia.	Price
66-199K	50"	16"	94.50
66-200K	60"	19"	147.95
66-201K	75"	24"	196.95



CCE3 MOORING BUOY

Comes with 3/4" diameter rod. Rod includes a swivel at the lower end and all rods are hot dipped galvanized.

Total Height, 29.1"(Rod included)

66-202K	207.00
---------	--------



JUMBO SHARPIE MAGNUM MARKER

Industrial-strength for the toughest marking jobs. Permanently marks on paper and most hard-to-mark surfaces including: corrugated cardboard, wood, metal, foil, stone, plastic, leather and more. Great for marking buoys or fish boxes. Marks on wet and oily surfaces.

68-849K	7.49
---------	------



SA-8 PLASTIC FLOAT (LOBSTER)

Plastic buoys made from 100% non-recycled material resistant to salt water, hard cold winters and UV rays with thicker walls and additional pressurization.

•8" Dia	
•14 1/2" Long	
•1 1/2" Eye Dia	
•Max Depth 45	
66-110A	Yellow P.O.R.



POLYFORM 2 EYE FENDERS

Outstanding quality, heavy duty twin-eye seamless fenders. Rotomoulded by use of our in-house developed and patented Polymatiq technology that ensures supreme control over the fusion process and guarantees an absolute even wall-thickness. Multiple rib-reinforced solid rope holds safeguard the highest breaking strength available. Resistant to all weather conditions. Tested in temperatures ranging from -30C to +60C.

	Dia. X Length	
66-204P	5" X 20"	32.95
66-205P	6" X 23"	46.95
66-206P	8" X 22"	64.95
66-207P	9" X 27"	73.95
66-208P	12" X 30"	152.95
66-669P	15" X 40"	262.95
66-638P	15" X 57"	342.95
66-639P	23" X 57"	462.95
66-675P	30" X 75"	875.00

POLYFORM 2 EYE UTILITY FENDERS

The POLYFORM™ G fenders are blow moulded from marine-grade vinyl material. These utility fenders are ribbed designed for added strength and abrasion resistance. The fenders are fitted with a POLYFORM™ non-return valve and securing valve screw.

The G fenders are suitable for smaller and medium size pleasure crafts.

	Dia. X Length	
66-1250P	4.5" X 16"	19.95
66-1251P	5.7" X 20"	26.95
66-1252P	6.7" X 23"	37.95
66-1253P	8.5" X 28"	52.95



MARINE FLUORESCENT ENAMEL

Interior/Exterior daylight fluorescent alkyd enamel for application where high visibility is required. Ideal for use as a safety marking, and for use on fire protection and life saving equipment, buoys and navigational aids. We recommend use of an undercoater before applying.

1 Litre can.

Coverage : 100 sqft/qt.

54-270K	Flame Orange	42.95
54-271K	Fire Red	42.95
54-272K	Flare Orange	42.95
54-273K	Signal Green	42.95
54-274K	Impact Yellow	42.95
54-275K	Ember Pink	42.95
54-276K	Lightning Yellow	42.95
54-279K	Horizon Blue	42.95



Because of limitations of printed reproduction, colours may not accurately match the bright, fluorescent colours.





5" & 6" LOBSTER & CRAB BLOCKS

Cast aluminum frames and sheaves, stainless steel shafts & bolts, galvanized swivel eye, grease fittings on shaft & swivel eye. Sheaves have stainless steel sleeves with bronze "Oilite" bushings. Drilled for spray shields.

46-520K5" - 1 1/2" throat clear.....	610.00
46-521K5" - 2 1/2" throat clear.....	635.00
46-522K6" - 3 1/2" throat clear.....	852.00

SPRAY SHIELDS

Complete with bracket for mounting on 5" or 6" blocks above. Stainless steel bracket, fabric reinforced rubber shield, stainless steel bolts.

46-746K5" Block	24.00
46-747K6" Block	24.00



WOODEN BLOCKS

Single sheave

46-280K 3"	22.95
46-281K 4"	30.95
46-282K 5"	43.95
46-283K 6"	60.95
46-284K 8"	109.95

Double sheave

46-274K 3"	37.50
46-275K 4"	54.95
46-276K 5"	74.95
46-277K 6"	116.95
46-278K 8"	194.95

Snatch Blocks

46-320M6"	124.95
46-319M8"	159.95

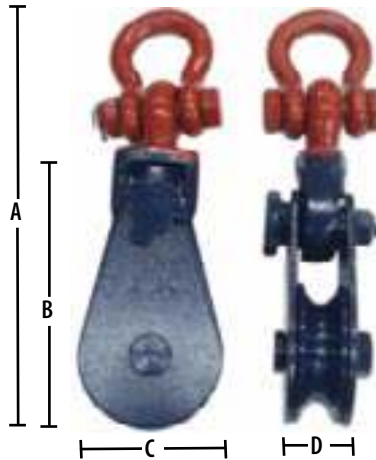

COMMERCIAL HEAVY-DUTY BLOCKS

3" Model

A = 9 1/2"; B = 6"; C = 3"; D = 3/4"

46-694MW.L.L. 4000lbs	54.95
---------	---------------------------	-------

4 1/2" Model

A = 14 1/2"; B = 9"; C = 4 1/2"; D = 1 1/8"

46-695MW.L.L. 8000lbs	97.95
---------	---------------------------	-------

6" Model

A = 19"; B = 12"; C = 6"; D = 1 7/16"

46-696MW.L.L. 16,000lbs	197.95
---------	-----------------------------	--------

8" Model

A = 21"; B = 13"; C = 8"; D = 2 3/8"

46-697MW.L.L. 16,000lbs	234.95
---------	-----------------------------	--------



CHAIN BLOCK

Commonly used on stabilizers to retrieve stabilizer fish. WLL 4:1, 3.6 tonnes.

46-570R	99.95
---------	-------	-------



YARDING BLOCKS

Pull pin to use as snatch block. Ideal for use on longliners. Super smooth bearing action with grease nipple. WLL 3:1

46-286M3" (1.5 ton)	34.95
46-287M4" (3 ton)	53.95
46-288M5" (4.5 ton)	87.95
46-289M6" (6 ton)	134.95
46-552M8" (8 ton)	236.95



STAINLESS STEEL YARDING BLOCKS

Same specs. as block above, but made of 316 stainless steel. WWL 3:1

46-851K8" (8 ton)	599.00
---------	-----------------------	--------



GALVANIZED CABLE

	Size	Min. Break Str.	Price per ft.
40-002R1/8"	1700	0.18/ft
40-003R3/16"	3700	0.34/ft
40-004R1/4"	7000	0.56/ft
40-005R5/16"	9800	0.83/ft
40-006R3/8"	14,400	1.14/ft

STAINLESS STEEL



STAINLESS STEEL CABLE (304)

	Size	Min. Break Str.	Price per ft.
40-049R1/8"	1700	0.45/ft
40-050R3/16"	3700	0.85/ft
40-051R1/4"	6400	1.30/ft
40-052R5/16"	9000	1.95/ft
40-053R3/8"	12,000	2.75/ft



SCEIN NETTING

CAPLIN (KNOTTED) 3/4" Mesh

- 66-180A#210/12 x 400MD x 100fms3/4"
- 66-181A#210/15 x 400MD x 100fms3/4"
- 66-183A#210/18 x 400MD x 100fms3/4"
- 66-184A#210/21 x 400MD x 100fms3/4"
- 66-182A#210/27 x 400MD x 100fms3/4"
- 66-179A#210/36 x 400MD x 100fms3/4"

All scein twines are price on request



HERRING AND MACKEREL (KNOTTED) 1 1/4" MESH

- 66-185A#210/15 x 400MD x 100fms1 1/4"
- 66-186A#210/18 x 400MD x 100fms1 1/4"
- 66-187A#210/21 x 400MD x 100fms1 1/4"
- 66-188A#210/27 x 400MD x 100fms1 1/4"
- 66-189A#210/30 x 400MD x 100fms1 1/4"
- 66-190A#210/36 x 400MD x 100 fms1 1/4"

SCEIN BORDER STRIPING (1 1/4" MESH)

- 66-980A#210/48 x 25MD x 100fms1 1/4"

All scein twines are price on request



CAST NET BALLS

- 66-223KP.O.R.



LOCALLY MADE CAST NETS FOR CAPLIN

- 66-033AP.O.R.



SCEIN FLOATS

Popular good quality scein float.

Hole with grommet for rope to 1 1/8" diameter

- 66-1120ASHE-20 7" X 5.3"P.O.R.
- 66-1121ASHE-25 7" X 5.8"P.O.R.
- 66-1122ASHE-30 7.5" X 6.2"P.O.R.



BARREL LEADS

For sinking cod traps or sceins, etc.

- 66-074A8ozP.O.R.
- 66-075A12ozP.O.R.
- 66-076A16ozP.O.R.



SALTER SCALE

Hanging scale. Plastic case to prevent rust. Weighs up to 220 lbs (100KGs)

- 70-096K195.00



PURSE SCEIN RINGS

Stainless Steel. Highly Polished

- 66-227K59.95
- REPLACEMENT SCEIN RING SPRINGS**
- 66-228KStainless 2.50



COVER SOLD SEPERATE FROM BOX

PLASTIC FISH BOX.

Assorted Colors.

- 66-072K150 lbs Capacity/No HolesP.O.R.
- 66-071KFISH BOX COVER.....P.O.R.



DEEP SEA PLASTIC FLOATS

- 66-210JP.O.R.



CRAB POTS

Call for further information on completed pots and jackets only. (#66-515)

- 66-511A.....5 3/8" x 4mmP.O.R.
- 66-515A.....5 1/2" x 4mmP.O.R.



CRAB POT NETTING

Compare our quality and price on crab pot netting. Inquire for size, color and other specs. Cut jackets also available, inquire.

- 66-602A.....4mm x 5 1/2" Mesh.....P.O.R.

Crab Jackets

- 66-502A.....4mm x 5 1/2" Mesh.....P.O.R.



BAIT BAG NETTING

Plastic netting in "Sock" design used to hold bait in lobster or crab pots. Also used for mussel socking.

- 66-358K.....Yellow (0.28" Mesh)0.24 per ft.
- 66-360K.....Black (0.52" Mesh)0.22 per ft.



CRAB POT CONES

- 66-225A.....P.O.R.



FISHTEK CRAB POT LIGHT

Advanced deep drop fishing light. Proven to increase catch rates in pot and trap fisheries. Auto immersion switch. Available in 3 colours.

4.13" x 1.57" x .87"

- 66-120A.....White.....P.O.R.
- 66-121A.....Green.....P.O.R.
- 66-122A.....Blue.....P.O.R.



PERFORATED BAIT JAR

Save costly bait by using our bait jar. Plastic construction, with vented screw lid and 4 tie tabs. 4 1/4" H x Approx. 4" diameter mouth.

- 66-516K.....P.O.R./ea.



CRAB POT SUPPLIES

SKIVERS

- 66-585A.....P.O.R./ea



CRAB MEASURE

Stainless Steel

- 66-434K.....95mm (3 3/4")12.95.



**Shop or Browse
Online 24/7
at**

mercersmarine.com



FINE MESH BAIT BAG

Bait bag with velcro closure and grommet.

9 3/4"W x 7 1/4" H

- 66-578K.....P.O.R./ea.



BAIT BAG (OC BRAND)

•Bait bag with velcro closure and 2 grommets.

•8.25" W x 9.25" H

•One side of bait bag is higher than other side for easy opening.

- 66-577K.....P.O.R./ea.

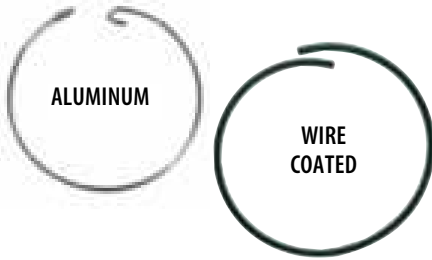

LOBSTER RINGS

ALUMINUM LOBSTER RINGS

66-369K.....5"	P.O.R.
66-370K.....5 1/2"	P.O.R.
66-371K.....6"	P.O.R.
66-372K.....7"	P.O.R.

WIRE "COATED" LOBSTER RINGS

66-376K.....5"	P.O.R.
66-377K.....5 1/2"	P.O.R.
66-378K.....6"	P.O.R.
66-379K.....7"	P.O.R.



LOBSTER BANDS

First quality, "cold water" lobster bands designed for cold North Atlantic waters.

66-139A.....1lb	P.O.R.
-----------------	--------



BUNGY - SHOCKCORD

Elastic cord used in lobster traps. Available in 500 ft spools or sold by the foot.

66-685K.....1/4"	0.25/ft
66-686K.....5/16"	0.38/ft
Shockcord Hook	
46-2105M..... Fits up to 5/16" Cord	0.49 ea



LOBSTER MEASURES

66-142K.....3 1/4" (Stainless Steel)	12.95
--------------------------------------	-------



LOBSTER BANDER

Top quality stainless steel tool designed to apply lobster bands over claws.

66-145K.....	15.95
--------------	-------

LOBSTER V-NOTCHER

66-514H.....	33.95
--------------	-------



LOBSTER POT HEADING TWINE

Commonly used for lobster pot heads. (Sold per pound)

210D/40 x 2 1/4" Mesh x 50 Mesh Deep	
66-217A.....Green	P.O.R
66-220A.....Yellow	P.O.R



NYLON SWIVELS

Stronger than plastic. Used on gillnets and lobster pots.

66-224K.....	2.69
--------------	------



LOBSTER POT ESCAPE HATCH

Used on lobster traps in NL. Manufactured with ABS plastic for long lasting life.

66-158K.....Single Clip 1 3/4"	1.79
--------------------------------	------





ESTERPRO SINKING TRAWL ROPE

Esterpro is a combination rope manufactured using continuous strands of high strength Polysteel fiber as an inner core being enveloped with specially matched polyester fibers. Offering more than 40% higher tensile strength than typical poly combo ropes and no lead core. It will not harden with age, has superior abrasion resistance, low elongation, excellent heat and UV resistance to rot and mildew. (samples available on request)

Ord. #	Size	Approx. lbs /coil	Price
66-720A	1/4" x 1800 ft	28 lbs	P.O.R.
66-721A	5/16" x 1800 ft	43 lbs	P.O.R.
66-722A	11/32" x 1200 ft	37 lbs	P.O.R.
66-723A	3/8" x 1200 ft	48 lbs	P.O.R.



POLYESTER TRAWL LINES

Black resined trawl lines. Approximately 300 fathoms per coil. Top quality!

66-484A	5.0 mm	P.O.R.
66-485A	5.2 mm	P.O.R.
66-486A	5.5 mm	P.O.R.
66-487A	5.8 mm	P.O.R.



BLACK BRAIDED GANGIONS

Braided nylon gangions. Supplied in 2 lb spools.

66-529K	#550 (Approx. 1000'/Spool)	P.O.R.
66-530K	#420 (Approx. 800'/Spool)	P.O.R.



BLUE TUNA LINE

Exceptionally strong with good stiffness. Used extensively as Gangions.

66-680A	150lb Test (Approx. 608')	P.O.R.
66-681A	200lb Test (Approx. 445')	P.O.R.
66-682A	300lb Test (Approx. 322')	P.O.R.
66-683A	400lb Test (Approx. 285')	P.O.R.



BROWNELL BLACK BRAIDED NYLON GANGION

The unique construction of Brownell's gangion resists twisting and tangling and will not unravel when cut. The material is treated with a specially bonded combination of type H and C-1 treatment to provide stiffness and excellent resistance to abrasion. 100% nylon. Supplied in 4 lb spools.

66-352K	#750 (Approx.2880' /Spool)	P.O.R.
66-353K	#550 (Approx.2120' /Spool)	P.O.R.
66-354K	#420 (Approx.1600' /Spool)	P.O.R.
66-355K	#280 (Approx. 1000' /Spool)	P.O.R.



SQUID ROLLER & JIGGERS

Flexible plastic sides (12" dia.) with 4" stainless steel center roller.

66-452A	Roller	P.O.R.
Color - Red. Sharp double hooks.		
66-368A	Jigger	P.O.R.



Stainless Steel

Steel

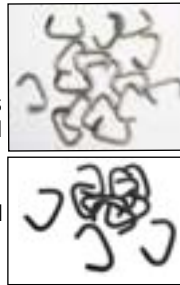

HOG RINGS & PLIERS

Supplied in 1 lb bags. Approx count per lb below.

66-673K	Hog Ring Pliers	P.O.R.
66-670K	3/8" S.S. Hog Ring (725 pcs)	P.O.R.
66-671K	1/2" S.S. Hog Ring (620 pcs)	P.O.R.
66-672K	3/4" S.S. Hog Ring (490 pcs)	P.O.R.
66-677K	1/2" Steel Hog Ring (465 pcs)	P.O.R.
66-678K	3/4" Steel Hog Ring (334 pcs)	P.O.R.



SNAP SWIVELS

66-781A	# 176 Halibut	P.O.R.
66-782A	#148 Mono (8/0)	P.O.R.

Not actual size.



HEAVY DUTY SHOVEL

Remco heavy duty, plastic type 14" shovel. Used extensively on fishing vessels and in fish plants.

20-388K	White	72.95
20-389K	Blue	72.95
20-390K	Red	72.95



FIBERGLASS HANDLE SHOVELS

13"W x 17"Deep Scoop.

20-555K	Fiberglass Handle 28"	58.50
20-556K	Fiberglass Handle 48"	70.95



WOODEN HANDLE SHOVELS

14"W x 18"Deep, Plastic Scoop.

20-386K	Wooden Handle 28"	41.95
13"W x 17"Deep, Aluminum Scoop.		
20-387K	Wooden Handle 28"	64.95



NORWEGIAN "GLOW" JIGGER

Popular Norwegian jigger with fluorescent glow coating.

66-454R.....5.3 oz. (150g)18.95



STINGSILD JIGGERS

Popular "herring shaped" jigger from Norway. Proven catch results over the years. 4 1/2 oz (125g).

66-640R.....Green/Silver12.95
66-643RYellow/Red12.95



SOLVPILK JIGGERS

Time Proven Cod catcher. 4 1/2 oz.

66-277RYellow/Red14.95
66-274RGreen/Silver14.95



JENSEN - PIRKEN LURES

The "Rolls Royce" of herring style lures. Cod can't resist.

66-402R.....Yellow/Gr./Red (2 oz)8.95
66-404R.....Green/Silver ,(2 oz)8.95



STINGSILD LURES

The worlds most famous lure. Special color combinations and hand painted eyes. 2.7 oz (75g)

66-400R.....Green/Silver8.95
66-401RGold/Red8.95

Genuine Norwegian

World's Best Selling Jigger!



NORWEGIAN JIGGERS

3oz. to 5oz. nickel plated. All others stainless steel.

66-001R.....3oz (75g)10.95
66-024R.....4 oz. (100g).....12.95
66-453R.....5.3 oz. (150g)13.95
66-002R.....6 oz. (175g).....17.50
66-004R.....9 oz. (250g).....17.95
66-005R.....14 oz. (400g).....22.95
66-006R.....18 oz. (500g).....24.95
66-007R.....21 oz. (600g).....26.95
66-008R.....26 oz. (750g).....29.95



NORWEGIAN JIGGER SWIVEL

66-572R.....2.95



STAINLESS STEEL RING

For use with Norwegian jigger.

66-330R.....Approx. 3/4" (19mm).....0.59 ea.
66-335R.....Approx 3/16" (11 mm).....0.29 ea.

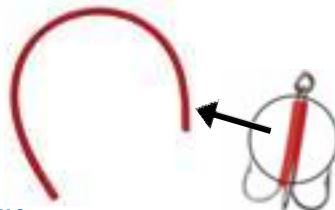

FISH TUBING

24" per pack. Red in colour.

66-1069RRED4.69
66-1068RORANGE4.69



DEEP DIVER LURES

4 1/2 oz with 4/0 triple hook.

66-1005R.....Green/Silver9.39
66-1006R.....Yellow/Orange9.39
66-1007RBlue/White9.39



COMPAC GLOW JIGG

Lead jigs coated with clear, hardened lacquers for a lustrous shine. Rigged with a nickel treble hook

66-1070R.....5 oz. (140g) Green12.29
66-1071R.....5 oz. (140g) Orange12.29
66-1072R5 oz. (140g) Silver.....12.29

66-1080R.....9 oz. (250g) Green19.49
66-1081R.....9 oz. (250g) Orange19.49
66-1082R9 oz. (250g) Silver.....19.49

SHOP 24/7 FROM THE COMFORT OF YOUR OWN HOME

- Up to date Pricing
- New Products
- Stock Status
- Additional product info
- And more



www.mercersmarine.com



COMPAC NEWFIE CHARM
66-1001R.....4 oz Silver12.59



COMPAC RIDGE MAC
40 grams / 1.5 ounces. Rigged with split ring and treble hook.

66-1375R Ridge Mac Nickel (1.5 oz)4.95
66-1376R Ridge Mac Blue (1.5 oz)4.95
66-1377RRidge Mac Chartreuse (1.5 oz).....4.95
66-1378R.....Ridge Mac Green (1.5 oz)4.95
66-1379RRidge Mac Red (1.5 oz)4.95



SAUCY DIVER
4 1/2 oz. 2/0 triple hook

66-1077R.....Yellow/Orange11.59
66-1084RGreen/White.....11.59
66-1101RSilver.....11.59



DIVING LURES DM140
Popular item for use with cod rods.

66-1008R Green 5oz (140g).....12.39
66-1054RYellow 5oz (140g).....12.39



COMPAC MAC JIG
4 oz / 110 grams. Glow-in-the-dark painted body. Rigged with skirted treble hook.

66-1105R Glo Mac Chartreuse (4 oz)11.49
66-1106R..... Glo Mac Green (4 oz)11.49
66-1107R..... Glo Mac Orange (4 oz)11.49



BULLET HEAD SQUID RIGS (3 HOOK)
80 lb test (main). 60 lb test (test). #7/0 hook. Ideal for cod, mackerel & haddock fishing.

66-011R Glow11.29
66-012R Pink11.29
66-013R..... Purple11.29



COMPAC SLIM MAC JIG MJ20
Ideal for herring, halibut, mackerel etc.

3/4 oz with #4 treble hook

66-1360R Slim Mac Blue (3/4 oz)5.39
66-1361R Slim Mac Green (3/4 oz)5.39
66-1362R Slim Mac Yellow (3/4 oz)5.39

5 oz lure with #3/0 treble hook

66-1367R Slim Mac Yellow (5 oz)12.69
66-1368R Slim Mac Green (5 oz)12.69
66-1369R Slim Mac Blue (5 oz)12.69



COMPAC FAT MAC JIG MJ40
Ideal for herring, halibut, mackerel etc.

1-1/2 oz with #4 treble hook

66-1363R Fat Mac Blue (1.5 oz)5.89
66-1364R Far Mac Green (1.5 oz)5.89
66-1365R..... Fat Mac Yellow (1.5 oz)5.89



FISH GAFF WITH HOOK
Locally made fish gaff with hook. Approx: 43" long.

66-032K15.95

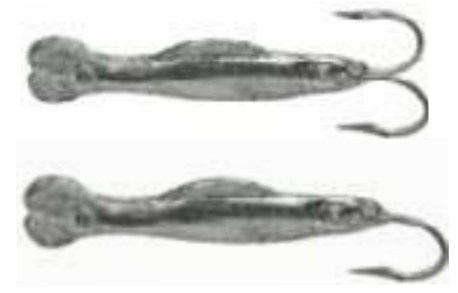

LEAD COD JIGGERS

66-016K.....16 oz. (1 hook)P.O.R.
66-017K.....16 oz. (2 hook).....P.O.R.
66-018K.....22 oz. (2 hook).....P.O.R.



HANDLINE LEADS
Used as sinker with baited hooks. Hole in top and bottom for attaching line and hook.

66-039RApprox. 10 oz.P.O.R.
66-040RApprox. 16 oz.P.O.R.



COMPAC NEEDLE JIG

- 66-1392R.....5 oz Green12.79
- 66-1393R.....5 oz Orange12.79
- 66-1394R.....5 oz Prism Silver.....12.79
- 66-1395R5 oz Prism Blue12.79



COMPAC NEEDLE JIG

- 66-1391R.....16 oz Silver.....27.95



SALT WATER TACKLE JADA GLOW FISH LURES

- 66-991P4oz.6.95



SALT WATER TACKLE DIAMOND FISH LURES

- 66-1031P4oz.7.19



SALT WATER TACKLE 5 OZ. FLUTED LURE

- 66-1020P5 oz.....7.19



SALT WATER TACKLE 5 OZ. EYEBALL LURE

- 66-1237P6.95



SALT WATER TACKLE 9 OZ. LURES

- 66-1233PYellow.....11.95
- 66-1234PGreen11.95
- 66-1235PRed11.95
- 66-1236PSilver.....11.95



SALT WATER TACKLE 5 OZ. CRIPPLED FISH LURE

- 66-1034P7.49



SALT WATER TACKLE 6 OZ. SHADE FISH LURE

- 66-992P6.95



SALT WATER TACKLE 4 OZ. PENCIL LURE

- 66-993P5.95



SALT WATER TACKLE 3 OZ. LURE

- 66-1227P5.95



SALT WATER TACKLE 5 OZ. BANANA LURE

- 66-1246P7.49



SALT WATER TACKLE 4 OZ. JADA LURE

- 66-1239PBlue6.95
- 66-1240PYellow6.95
- 66-1241PGreen6.95



SALT WATER TACKLE 7 OZ. LURE

- 66-1229P8.95



SALT WATER TACKLE 2 OZ. LURE

- 66-1226P4.95



SALT WATER TACKLE SILVER FISH LURES

- 66-1032P4oz.6.95



COMPAC COD CANDY

- 80 lb main line. 60 lb branch. 3, 7/0 hooks.
- 66-1079R.....3 hooks (Cod)7.39



SALT WATER TACKLE 5 OZ. HOT LIPS LURE

- 66-1243PYellow.....7.29
- 66-1244PPink.....7.29
- 66-1245PGreen7.29
- 66-1247PGlow7.29



SALT WATER TACKLE 5 OZ. GLOW SQUID WITH HOOK

- 66-1248P6" Long.....6.95



BAITED HOOKS C/W SWIVEL (RED)

Time proven method of catching cod. No bait required.

66-026P.....	6/0	1.59
66-027P.....	8/0	1.79
66-028P.....	10/0.....	2.39
66-030P.....	12/0.....	3.79



BAITED HOOKS C/W SWIVEL (YELLOW/RED)

Time proven method of catching cod. No bait required.

66-173P.....	10/0	2.39
66-175P.....	12/0	3.79



BRASS SNAP & BARREL SWIVELS

66-313R.....	5/0 SNAP SWIVEL	0.99
--------------	-----------------------	------



HEAVY DUTY HANDLINE SWIVELS

66-020R.....	6/0 HANDLINE SWIVEL	2.29
--------------	---------------------------	------



FLY BAITS

Proven method of catching cod and mackerel. Use with a handline lead or above your jigger. **Heavy Duty.**

66-387P.....	3 hooks (Cod)	6.49
66-388P.....	5 hooks (Cod)	6.95



RUBBER WORM BAITS

Feathered 704B hooks with green translucent rubber bait covering. Sold in packs of 3.

66-995P	5.09/pk.
---------------	-------	----------



RED DEVIL LURES

66-975R	4 1/4"	4.39
---------------	--------------	------

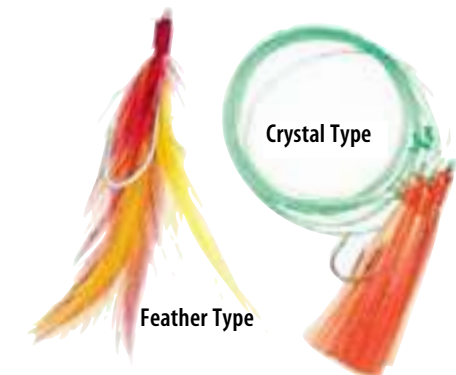

Crystal Type

Feather Type

BAITS WITH MONO LINE - COMPAC

Complete on Mono Line

Mackerel (Feather Type)

66-009R	3 hook/40 lb Test (Mackerel).....	2.79
66-010R.....	6 hook/ 40 lb Test (Mackerel)	3.79

Mackerel (Crystal Type)

66-015R.....	3 hook/40 lb Test (Mackerel).....	3.39
--------------	-----------------------------------	------

Cod (Feather Type)

66-019R ...	3 hook/ 120 lb Test 7/0 Hook (Cod)	3.49
-------------	--	------

Cod (Crystal Type)

66-1078R ..	3 hook/ 80 lb Test 6/0 Hook (Cod)	4.29
-------------	---	------



COMPAC FEATHERED SABIKI RIG

Three single 3" drop lines rigged to help position bait perfectly while preventing line twist. 52" monofilament line. 3" drop line. #2 hook.

66-1449R.....	Red/Yellow.....	4.09
---------------	-----------------	------



3 HOOK MACKEREL FLY BAITS

66-395P.....	80 lb	5.69
--------------	-------------	------



TRIPLE HOOKS

Without Red Bait. (Mustad)

66-1061K.....	6/0	P.O.R.
66-1063K.....	8/0	P.O.R.
66-1064K.....	9/0	P.O.R.
66-1065K.....	10/0	P.O.R.
66-1066K.....	11/0	P.O.R.
66-1067K.....	12/0	P.O.R.

Triple Hook with Bait & Ring. (Not Mustad)

66-977R.....	6/0	2.79
--------------	-----------	------



Red/Glow



Red/Blue

COMPAC WINGED SABIKI RIGS

Five single 3" drop lines rigged to help position bait perfectly while preventing line twist. 52" monofilament line. 3" drop line. #4 hook. 25lb test (main). 15lb test (branch).

66-1451R.....	Red/Glow	4.09
66-1450R.....	Green/Glow	4.09

COMPAC WINGED SABIKI RIGS WITH SWIVEL

Five single 3" drop lines rigged to help position bait perfectly while preventing line twist. 52" monofilament line. 3" drop line. #4 hook. 25lb test (main). 15lb test (branch). #7 swivel with safety snap.

66-1452R.....	Red/Blue	4.09
66-1453R.....	Red/Crystal	4.09



12 HOOK COMPAC MACKERAL LINE

98" main line, 250 lb test mono. 12 x 2.5" dropper lines, 180 lb test mono. Dropper spacing 6"

66-1460R.....	Green	19.95
66-1461R.....	Red	19.95

15 HOOK COMPAC MACKERAL LINE

119" main line, 250 lb test mono. 15 x 2.5" dropper lines, 180 lb test mono. Dropper spacing 6"

66-1462R.....	Green	23.95
66-1463R.....	Red	23.95

20 HOOK COMPAC MACKERAL LINE

119" main line, 250 lb test mono. 20 x 2.5" dropper lines, 180 lb test mono. Dropper spacing 6"

66-1464R.....	Green	29.95
66-1465R.....	Red	29.95



COMPAC WEIGHTED STRIPER RIGS

54" line. #6/0 O'Shaughnessy hook

66-1454R.....	2 oz.....	6.89
66-1455R.....	3 oz.....	7.39

COMPAC STRIPER RIGS

100 lb test. #2 barrel swivel. #6 coastlock snap. 24" nylon coated wire. 4" drop line

66-1456R.....	Orange	6.29
66-1457R.....	Red	6.29



KAMAKAZI HOOKS

Turned up eye reversed. Chemically sharpened, high carbon steel. Excellent tensile strength.

66-1466R.....	7/0 (4 per pk)	4.59
66-1467R.....	8/0 (3 per pk)	4.59



TEAR DROP LURES

Ideal for Perch, Bluegill, Small Mouth Bass and Trout. Chip resistant paint with epoxy finish for durability in extreme weather.

66-1469R.....	#10 Hook/Orange	2.79
66-1470R.....	#10 Hook/Red	2.79
66-1471R.....	#8 Hook/Orange	2.79
66-1472R.....	#8 Hook/Red	2.79

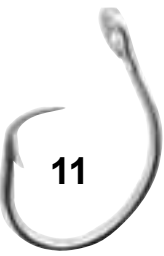

11



12



13



14



16



11/0



12/0

POWER BAITERS/E-Z BAITERS

66-296A.....	11/0	P.O.R.
66-297A.....	12/0	P.O.R.



Not actual size

GAFF HOOKS

7" LONG	
66-239P	LG 4.49
8" LONG	
66-240P	XL 5.99



#1 JIGGER HOOK (FLAT END)

66-302A	#1	P.O.R.
---------------	----------	--------

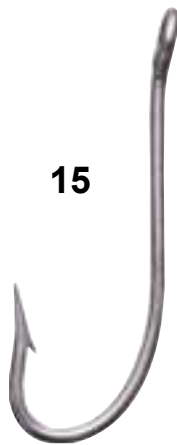

15



16

Approximate Sizes Shown



FISH GAFF WITH HOOK

Locally made fish gaff with hook. Approx: 43" long.	
66-032K	P.O.R.



#14
704B

SHORT SHANK CIRCLE HOOKS

Sold in boxes of 100 hooks.

66-738A.....	11/0	P.O.R.
66-739A.....	12/0	P.O.R.
66-740A.....	13/0	P.O.R.
66-741A.....	14/0	P.O.R.
66-742A.....	15/0	P.O.R.
66-743A.....	16/0	P.O.R.

GRAVITATION HOOKS

Sold in boxes of 100 hooks.

66-284A	#15	P.O.R.
66-285A	#16	P.O.R.
66-283A	#14 (704B)	P.O.R.

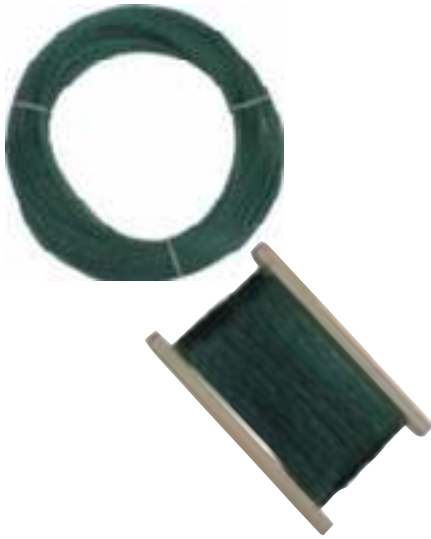

MERCER'S COD ROD MONO LINE

Soft monofilament line in 30lb test for use with "COD RODS". 300ft per spool.

66-1023R.....3.25



24" STAINLESS STEEL LEADER

3 leaders per card. Helps eliminate line twist when casting or trolling revolving spoons and spinner type lure. Black, nylon coated stainless steel wire. Rigged with a ball bearing swivel and a crosslock snap. Wire wound at both ends for extra strength. 40 lb test.

66-978R.....3 pcs per pk.11.95

MERCER MONO LINES & REELS

An excellent "super soft" mono line. Coils well. Compare our quality and price. Comes in 50 fathom coil.

66-146R.....	80lbs.....	2.50
66-154R.....	95 lbs.....	2.75
66-147R.....	125lbs.....	4.25
66-148R.....	150lbs.....	4.95
66-149R.....	185lbs.....	5.75
66-392R.....	220lbs.....	8.65
66-150R.....	250lbs.....	10.95
66-151R.....	300lbs.....	13.50
66-152R.....	400lbs.....	20.95
66-483R.....	500lbs.....	26.50



BRAIDED SURELINE

High knot strength with zero stretch. Waterproof and UV resistant. Special coating for smooth line feed. Great item for Cod Reels. 450' per roll.

66-1048R.....80 lb Test19.95

66-1049R.....100 lb Test19.95



HIGH VIZ LINE

High visibility yellow monofilament line. High knot strength. Superior abrasion resistance. Round profile helps prevent line from digging in. 150 yards / 137 m.

66-1102R.....20 lb Test6.39



WOODEN JIGGER REEL

Reel sold without line.

66-041K.....	Plain.....	4.95
66-042K.....	Stained/Coated.....	6.49



MACKEREL LINE

High visibility blue-green monofilament. High knot strength. Superior abrasion resistance. Near invisible under water. 450'

66-1044R.....20 lb Test6.39

66-1045R.....25 lb Test6.39



BRAIDED TROUT LINE

The Compac Braided Line in Spool offers all the characteristics that anglers love: smooth, long and easy casting, and durability. Comes with 50 yards per spool and are made to last in Canadian waters. Excellent for ice fishing.

66-1047R.....20 lb Test9.79



BRASS POCKET SCALE

70-127R.....50 lbs10.59



PERKO ROD HOLDER - ANGLED FLUSH MOUNT

Chrome Plated Zinc Alloy Flange. Angled Flush Mount (Approximately 65°). Anodized Aluminum Tube. Soft Black Liner. Includes Flange Gasket with Integral Flip-Up Cap. D01 & DPD - Integral Drain Bib for 5/8 Inch I.D. Flexible Hose.

46-1112R.....99.15



STAINLESS STEEL ROD HOLDER WITH CAP

Stainless steel flush mount rod holder. 1-7/8" x 9-1/2".

46-1107R.....19.95



CASPIAN HD RODS

5'6" medium-heavy action rod. Solid glass composite blank. Cushioned stainless steel hooded reel seat. Heavy duty stainless steel guides. Heavy duty EVA grips.

66-1021R.....5 1/2 ft, 1pc-Blue47.95

66-1022R.....5 1/2ft, 1pc-Red47.95



RAM-ROD 2007 ROD HOLDER

The RAP-340 consists of the RAM-ROD™ 2007 rod holder, single socket and 1.5" ball with a 2" X 2.5" flat surface base that contains the universal AMPs hole mounting pattern. Designed to mount horizontally in your boat or kayak, you can rotate the rod holder 360 degrees, while tilting the cradle forward and back for the optimum angle. Ideally suited for vessels as small as kayaks, to larger Tournament or Charter boats, this new line of products is guaranteed to please. Incorporating our one of a kind and patented ball and socket feature, perfect adjustment is a breeze and setting the hook could not be faster.

26-067K.....39.95



RAM-TUBE 2008 ROD HOLDER

The RAP-119 consists of the RAM-TUBE 2008 fishing rod holder and 2.5" diameter round base that contains the universal AMPs hole pattern. Offering the patented RAM rubber ball, socket and ratcheting feature, you can rotate the rod holder 360 degrees, while tilting the cradle forward and back for the optimum angle. The RAM-TUBE 2008 tube holder integrates the patented rubber ball and socket design with a self draining and quick to access tube for the butt of most any fishing rod. The tube is made of extremely durable composite. Ideally suited for anything from Kayaks to Tournament boats. Tube Dimensions: Inner diameter: 1.9" Inner tube length: 10" (from bottom to top of lip)

26-071K.....45.95



ZEBCO ROD/REEL COMBO

Heavy Boat Rod w/Stinger 80 Series Reel Combo. Reinforced graphite core. Aluminum reel collar. 6 Dyna Flow guides. Reel is pre-spooled with 165yds of 25lb test. 5.1:1 gear ratio. Ball bearing drive. Quick anti-reverse system. Graphite spool. Right or left retrieve

66-1420P 6', 1pc.....74.95



ROD HOLDER

6 Rod Storage Rack. Black, 13 1/2" long. Designed for Horizontal use. (Price per pair)

46-1108R.....10.95



SPARTAN BOAT RODS

Precision tapered solid blank. Stainless steel hoods. WEG bridge frame ceramic guides. EVA grips. Cushioned rubber butt cap. Available as a one piece or a two piece. Also available in White or Black.

- 66-1053R.....Med Light, 5 1/2 ft, 2pc44.95
- 66-1011R .Med Heavy (WHITE), 5 1/2ft, 1pc.....38.95
- 66-1012R .Med Heavy (BLACK), 5 1/2ft, 1pc.....38.95



HUSKY BOAT RODS

Solid glass blank. Black titanium oxide ring armour guides. Stainless steel hoods. EVA grips. Rubber butt cap.

- 66-1013R.....Medium Heavy, 5'6", 1pc.....49.95



CASPIAN BOAT RODS

6 ft glass solid blank. 4 double stainless steel foot guides. Non-slip EVA handle.

- 66-1037R.....Heavy, 6ft, 2pc62.95



HEAVY DUTY SHARK ROD

Solid fiberglass construction. Graphite reel seat with cushioned stainless steel hoods. Heavy duty aluminum roller guides & tip for smooth line feed. EVA handles with removable rubber butt cap for convenient placement into a rod holder.

- 66-1052R.....Heavy Duty, 5'6", 1pc.....148.95



WILD WATER ROD/REEL COMBO (WW550)

Reel Specs: 1 ball bearing. Oversized line roller. Stainless steel bail trip. Convenient clip on spool. Front drag. Left/right hand retrieve. Silent anti reverse. Fold down handle. Salt water safe. Line Capacity: 220yds/16lb; 170yds/20lb; 140yds/24lb. Gear ratio: 4.1:1.

Rod specs: 1 piece, 5'6" long. Precision tapered solid blank. Medium heavy action. Stainless steel hoods. WEG bridge frame ceramic guides. Cushioned rubber butt cap with EVA grips.

- 66-1050R..... 5'6", 1pc.....79.95



NORTH SEA COD KING ROD

1 piece 5 1/2' solid fiberglass construction. Luminous, rich grey blank, gold wraps on guides. Orange - black cross wrapping. Super heavy construction to handle the toughest of fish. Front & rear EVA handle with rubber butt cap. Graphite reel seat with cushioned stainless steel hoods. Heavy duty, silver and gold double foot ALOX guides and tip. Guides suitable for braided lines

- 66-1051R.....Heavy, 5'6", 1pc76.95



EMERY ROD & REEL COMBO

Front drag. 1 ball bearing. Silent anti-reverse. 5'6" solid glass blank. Stainless steel double foot guides, ceramic inserts. EVA grips with cushioned rubber butt cap. Graphite reel seats with stainless steel hoods. Available in blue or red.

- 66-1029R5 1/2 ft, Blue81.95
- 66-1030R5 1/2ft, Red81.95



STINGER ROD/REEL COMBO

The Emery Stinger is a great starter spinning combo. Expertly matched to bring out the best, this combo is great for those weekend trips up at the cottage. Counter weight reel handle. Black rod with gold trip. Single foot ceramic guides. Pre-spooled reel. 1 BB, Rear drag.

- 66-1046R 6', 1pc.....60.95



WILD WATER ROD/REEL COMBO (WW900)

Front drag. 1 ball bearing. Oversized line roller. 2 piece, tubular composite blank. Medium action. Double foot guides with ceramic inserts. Stainless steel hoods. EVA handle with rubber butt cap. Primarily used for fishing Bass, or Mackrel from onshore.

- 66-1024R 9', 1pc.....83.95



SEA MASTER SM360 REEL

1 ball bearing. Long cast system. Oversize line roller. Silent anti-reverse. Front drag. Right/left hand retrieve.

66-1040R.....58.95



FD 360

Line capacity (lb/yd): 14/340, 16/270, 18/220
Gear ratio 4.1:1. 1 ball bearing. Front drag. Silent anti-reverse. Oversized line roller. Graphite Construction. Right/Left hand retrieve.

66-1016R.....59.95



COMMANDER SPINNING REEL (FD460)

3 ball bearing. Graphite construction. Vented graphite spool. Front drag. Brass oversize line roller. Carbon steel main shaft. Zinc coated brass pinion gears. Right/left hand retrieve.

66-1039R.....66.95



FALCON FISHING REEL

One touch bait runner lever and tension dial. Aluminum spool. Infinite anti-reverse. Brass gear.

66-1014R.....87.95



DMAX 60 REEL

Line capacity (lb/yd): 15/250, 23/180, 32/110
6 ball bearing. Front drag. Infinite anti-reverse. Brass gears. Gear ratio 4.3:1. Vented aluminum spool. Spare/extra graphite spool included. Fold down handle with wood grip. Right/left hand retrieve. Long cast spool system.

66-1015R.....103.95



LEGEND™ DOWNRIGGER REEL (DRC500)

2 Stainless steel ball bearings. Durable & saltwater safe. Graphite frame and spool. Star drag.

66-1025R.....122.95



SPARTAN FISHING REEL

8 ball bearings. Zinc gears. Infinite anti-reverse. 1-way clutch. One touch Free Runner lever with tension dial. Aluminum spool & bail. Bonus graphite spool.

66-1042R.....142.95



SKR80 REEL

GEAR RATIO: 5.1:1. Line capacity: (LB/Yds) 30/260, 40/180, 50/150. Fully Shielded Stainless ball bearings for maximum protection against salt water. 5 ball bearing + 1 way clutch. Vented aluminum spool. Front drag. Long cast spool. Zinc gears. Copper line roller. Aluminum bail. Left/right hand retrieve. On/Off anti-reverse switch. Fold down handle with rubberized grip.

66-1041R.....135.95



PREDATOR REEL

Line counter (in feet). 3+1 ball bearings. Anodized aluminum spool. Lightweight corrosion-resistant frame & side plates. ON/OFF bait clicker. Star drag. Tension knob. Gear ratio 4.5:1. Line capacity (lb/yd) 25/490; 30/380

66-1026RRight Retrieve.....159.95

66-1027RLeft Retrieve.....159.95



FLY ROD "ELITE" TELESCOPIC
 IM7 graphite blank. Black aluminum reel seat. Dual locking rings. Grade AAA Portuguese cork grip. Western style handles. 8 sections telescope out to 9'0".
 20-1267M.....9' 2pc #8.....119.95



FLY ROD "ELITE"
 Elite is our basic fly rod series designed to introduce you to the incredible world of fly fishing. With two different style handles and a large variety of lengths and line weights, an Elite fly rod is the perfect way to develop a real feel for the sport. Features -IM7 graphite blank - Black aluminum / cherry wood reel seat -Dual locking rings -Grade AAA Portuguese cork grip.
 20-1268M.....9' 2pc #8/9 (Hard Case Inc.)145.95
 20-1270M.....9' 6" 2pc #8/9145.95
 20-1266M.....9' 6" 2pc #5145.95



FLY ROD "SERENITY"
 Serenity Series fishing rods are a pleasure to fish with as they provide entry level anglers to seasoned pros with an affordable, long casting rod that is easy to use. The Serenity is equipped with high end components including a graphite blank, carbon reel seat, strong titanium rings and grade AAA Portuguese grip. As an added bonus the rod now comes with a hard rod case.
 20-1275M9' 2pc #8/9215.95



"SUNSET" CRUISER ROD CASE 66"
 Protect your valuable fishing gear with the Streamside Sunset Cruiser Rod Tube. Case is 66" long, will fit up to 10' rods and features a padded shoulder strap and travel tag pockets.
 20-1296M.....67.95



"MAINSTREAM" ROD CASE 56"
 Transport and store your rods easily with the Streamside Mainstream Tube 56" rod case. Made of Denier Cordura material with heavy duty nylon interior lining, this case fits up to 9'6" rods. Crushproof.
 20-1295M.....45.95



FLY ROD "SERENITY"
 GX2 Graphite (IM8) blanks. SiC guides. Carbon reel seat. Titanium rings. Grade AAA Portuguese cork grip. Comes with a soft cloth fly rod bag and a hard rod case.
 20-1276M9' 4pc #8/9231.95



FLY REEL "ELITE"
 Aluminum die cast construction. Salt water safe.
 20-1283M.....LW-6/8.....62.95
 20-1284M.....LW-9/1172.95



FLY REEL "SYMPHONY"
 An excellent die cast black anodized aluminum reel with the versatility of large arbor performance and a wicked drag with red highlighted plate cover make this black widow beauty the envy of other anglers.
 Features
 -Rubberized handle grip
 -Convertible left/right hand retrieve
 20-901M.....LW-7/8121.95



FLY REEL "ACCORD"
 An excellent reel for salt water or fresh water conditions. Machined aluminum and anodized surface. Centre disc system. 1-way clutch. Medium arbour spool. Convertible left/right hand retrieve.
 20-1281M.....LW-7/8174.95
 20-1282M.....LW-9/10184.95



OLD TYPE TROUT BASKET WITH STRAP

Offers complete ventilation ensuring your catch stays fresh while you search for another. The creel is hand crafted and features an adjustable leather strap which can be set to your size for easy transportation.

Dimensions: 16" x 7" x 7"
20-192M74.95



WOODEN DIPNET

Dimensions: 20 1/2" Overall Length x 9 1/2" Width
20-916H22.95



SALMON SCALE AND TAPE MEASURE

Designed for accurate readings, this device allows you to weigh fish up to 28lbs/ 12kg, and measure up to 40".
20-1332M.....11.29



FAST LINE CLIPPER

Metal clipper on one end. Jig head eye cleaner on the other end
20-1330M4.89



SILICONE FLY CASE

Double sided. High density slit foam. Easy snap closure.
20-1305M4" X 3"24.95
20-1306M6" X 3.75"29.95



BL100S FLY-BACKING LINE (100YD)

Single Spool Fly Line Backing is designed so that it won't rot, grow mildew or tangle on you. Sporting a highly visible chartreuse colour, this backing is 20lbs of ultra-thin braided line.
20-1310M.....17.95



BACKWOODS KODIAK HUNTING KNIFE

All purpose knife. 10 1/2" overall length. Blade is 6". Comes complete with leather sheath.
22-060M145B54.95



BACKWOODS GUTTING KNIFE & HOOK - FOLDING

Easy-to-grip rubber handle. Folding blade with gut hook. Comes with nylon case.
22-092M.....3 1/2" Folding Blade18.95



BLL-50 LEADER LOOPS (50LB)

Braided Leader Loops will save you precious fishing time. The easy to use loops simply attach to the end of your fly line, allowing you to quickly add on a leader. Loops can be used with floating or sinking fly lines and come available in 3 packs.
20-1325M.....5.95



BACKWOODS GUTTING KNIFE & HOOK- FIXED

Easy-to-grip rubber handle. Fixed blade with gut hook. Comes with nylon case.
22-099M5 1/4" Fixed Blade.....26.95



BACKWOODS GUTTING KNIFE & HOOK

Easy-to-grip rubber camo handle. Comes with nylon case.
22-093M4" Fixed Blade.....22.95



DELUXE SALMON FLOAT LINE

105 ft, 32 meters, fluorescent orange line. Exposed loop allows for greater sensitivity and quick leader changes
20-1315M#836.95
20-1316M#936.95



GREEN RIVER™



BUTCHER KNIFE

- 22-019M6"(Model 012-6B).....31.95
- 22-506M8"(Model 012-8B).....38.95
- Heavy Duty Leather Sheath for 6" Model.
- 22-020K.....For 012-6B19.95



6" SKINNER- PELTING KNIFE

- 22-024M(Model 012G-6).....32.95
- Heavy Duty Leather Sheath
- 22-101K.....For 012G-619.95



5 1/4" SKINNING

- 22-021M(Model L012G)31.95
- Heavy Duty Leather Sheath
- 22-022K.....For L012G19.95



6" BONING KNIFE

- Wide blade style. (Cut-throat or Boning).
- 22-200M#21945-622.95



6" DEXTER BONER

- 22-030M(Model 1376R)31.95



6" BONING KNIFE

- 22-025M(Model S13G6NR)36.95



DEXTER DEBONING KNIFE 4 1/2" BLADE

- 22-505M4.5" blade.....18.95



SPLITTING KNIFE (Not Dexter/Green River)

Made exclusively for Mercer's Marine

- 22-111MRight Hand24.95
- 22-112M Left Hand24.95



DEXTER RUSSELL 8" BUTCHER KNIFE

- 22-033M(S112-8)46.95



DEXTER RUSSELL 8" TIGER EDGE SLICER KNIFE

- 22-126M(SG142-8TE)37.95



DEXTER RUSSELL 8" BREAKING KNIFE

- 22-515M(SG132N-8)47.95



DEXTER RUSSELL 5" CUT AND GUT KNIFE

- 22-511M(P11893).....19.95



DEXTER RUSSELL 4" NET KNIFE W/SHEATH

- 22-512M(P10885).....19.95



GREEN RIVER™



5" NARROW BONER

22-196M.....P9482014.95



4 1/2" TRIMMING KNIFE/SANI-SAFE

22-027M.....(Model S154-HG)25.95



6" BONING KNIFE/SANI-SAFE

22-026M.....Straight Blade (Model S156-HG)30.95

22-036M.....Serrated Blade (Model S156-SC)24.95



BONING KNIFE

"Good cut-throat style" 6" long, wide blade style.

22-197M.....P9481816.95



FILLET KNIFE

22-155MP94812 - 7"15.95

22-156MP94813 - 8"16.95



7" FILLET KNIFE/SANI-SAFE

22-149M(Model S133-7)35.95



PLASTIC KNIFE SHEATH

Sturdy Polypropylene. Works with all 5" to 8" Sani-Safe or Softgrip Handle, narrow or wide boning/filleting knives.

22-097M(WS-1)13.95



3 1/4" KNIFE

22-031MSerrated Blade (Model NTL-24)10.95



6" STIFF BONER/SANI-SAFE

22-028M(Model S136)31.95



6" BUTCHER KNIFE/SANI-SAFE

22-023M(Model S112-6)39.95

22-020KOptional Leather Sheath19.95



3 1/2" UTILITY/NET KNIFE & SHEATH

22-157M.....(S151SC-GWEWS)19.95



DIAMOND KNIFE SHARPENER!

DIAMONDS ARE IN... DULL IS OUT!!! Smoothest stroking. Sharpest results...

Once you've tried it you will use no other!!

22-100M.....10"59.95



6" V-LO NARROW BONING KNIFE

22-201M(V136N-PCP)36.95



7" V-LO FILLET KNIFE

22-202M.....(V133-7PCP)39.95



4 1/2" FISH OR SKINNING KNIFE

22-029M(1674-1/2)26.95



4" FISH KNIFE

22-065M(10281)23.95



Icel knives are known worldwide for quality and durability. Manufactured in Portugal since 1955, Icel is used by professionals throughout the food industry. The Icel "Fish" Knives with red handles below are manufactured with high carbon surgical steel blades & have poly/santoprene sure grip handles.



6" ICEL SKINNER/PELTING KNIFE

- 22-440M33.95
- 22-101KOptional leather sheath19.95



6" ICEL STIFF BONING/CUT THROAT KNIFE

- 22-441M28.95
- 22-103KOptional leather sheath19.95



7" ICEL FILLET KNIFE

- 22-442M28.95



5 1/2" ICEL TRIMMING KNIFE

- 22-446M21.95



10" BUTCHER KNIFE

- High Quality, European Made. Anti-Slip Handle & Polished Blade
- 22-445M10"56.95



ICEL POCKET KNIVES

- Model 142.1101
- 22-425PBlade = 2 5/8" (#9).....32.95
- 22-426PBlade = 3" (#10).....33.95
- 22-427PBlade = 3 3/8" (#11).....42.95
- 22-428PBlade = 3 5/8" (#12).....52.95



Rapala

RAPALA 4" CERAMIC UTILITY KNIFE

These knives feature a super-sharp, super-tough ceramic blade. 2X sharper and 15X edge retention compared to steel. That all translates to, you never need to sharpen them. Lightweight, non-porous and incredibly corrosion resistant, they never rust. Molded soft grip handle for ultimate comfort. Compression sheath holds tight for safe storage and transportation.

- 22-295M4" Blade - 4 1/2" Handle.....15.95



Rapala

RAPALA 6" FILLET

•Stainless steel blade with plastic sure-grip handle. One of the best buys in today's market!

- 22-182MModel 126.....10.95



Rapala

RAPALA "SOFT GRIP" FILLET KNIFE

•Famous Rapala flexible blade with "soft-grip" handle
•Comes complete with leather "Laplander" sheath with sharpener .

- 22-267M6" Model (BP-706-SH1).....28.95
- 22-268M7" Model (BP-707-SH1).....36.95



SWISS QUALITY SINCE 1855

The Blade: High quality stainless steel blades are hand finished in Switzerland by Victorinox® skilled Craftsman. The Handles: Victorinox handles are ergonomically designed for minimum wrist tension. Patented Fibrox® handles are NSF approved and slip resistant.



6" SKINNER / PELTING

22-233M.....#5.7803.1549.50
22-101K.....Optional leather sheath19.95



6" SKINNER

22-232M.....#5.7703.1549.50



12" CIMETER

22-209M.....#5.70303.3199.95



6" BONER

22-172M.....#5.7603.1549.50



6" BONER

22-171M.....#5.6003.1536.50



FLANK KNIFE

22-178M.....7"48.50
22-179M.....8"48.50



3 1/4" TWINE KNIFE

22-234M.....#5.0631.....9.49
22-341M.....belt sheath10.95

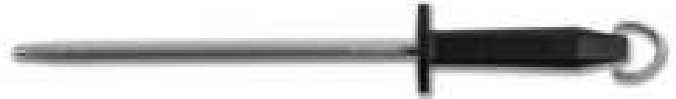

10" REGULAR CUT STEEL

22-175M.....#7.8991.3248.50



FLANK KNIFE

22-178M.....7" (41511)48.50
22-179M.....8" (40534)48.50



6" BONER

22-231M.....#5.6503.1536.50



VICTORINOX PARING KNIFE

22-235M.....Straight Blade 3-1/4"10.29



VICTORINOX PARING KNIFE

Pointed tip.Ergonomic handle.Dishwasher safe.

22-236M.....Orange Handle9.49
22-237M.....Yellow Handle.....9.49



VICTORINOX BLADE GUARD

Universal design in 3 different sizes to meet most knife storage needs. Keeps sharp knife edges safe for transport or storage. Knife not included.

22-305M.....For 4.5" Blades5.95
22-306M.....For 6" Blades.....6.50
22-307M.....For 8" Blades.....7.95

MORAKNIL



6" MORA FILLET KNIFE

6" Cold-rolled stainless steel blade with high friction rubber grip. Medium flex blade. Easy clean vented plastic sheath. Comes with 2 interchangeable belt attachments. Made in Sweden.

22-012M55.95

TRAMONTINA KNIFE

Stainless steel blade. Antimicrobial handle.

22-910M7"26.95

22-911M10"25.95



TRAMONTINA 12" SALMON FILLET KNIFE

Stainless steel blade. Antimicrobial handle.

22-912M12"21.95



6" MORA BUTCHER KNIFE

Blade of Swedish stainless knife steel that can be sharpened to extreme sharpness and high edge retention. Blade hardened by deep refrigeration. Handle: Polyamide handle with a microblasted structure for optimum friction. Significant finger guard and finger grips.

22-905M58.95



5" MORA BONING KNIFE

The knife has a polypropylene handle with a rough structure, a valuable property. The blade is 5" long and made of Swedish cold-rolled stainless steel, hardened by means of deep refrigeration.

22-907M31.95

8" MORA FILLET KNIFE

Plastic molded handles with rough surface. Flexible stainless steel blades.

22-900M8"57.95

DEXTER



4 INCH BONING HOOK 1/4 INCH DIAMETER

22-508MS193H20.95



CLIPPER KNIFE & CASE

Fluorescent orange colour. Ideal for search and rescue. Non-slip grip handle. 4" stainless steel blade. With sheath.

22-011MStraight Blade25.95

22-014MSerrated Blade31.95



MORA KNIFE & CASE

3.6-inch fixed-blade utility knife with Sandvik stainless steel blade. Impact-resistant plastic handle with larger shape fits comfortably in the hand. Hard plastic Combi-Sheath allows for the connection of a second knife and sheath. Made in Sweden

22-303M15.95



GRUNDENS DECK KNIFE

Features a sheath with a belt clip and a secure clamp so it can be worn with pants or waders. Thin 440 stainless blade, easy to hold ergonomic handle.

18-3055KDeck Knife & Case26.95

18-3054KBelt for Knife12.95



19" STAINLESS MEAT SAW

ABS handle. 4-3/4" tension handle. 19-1/2" x 5/8" stainless steel blade. Heavy-duty plated rectangular frame. 6" clearance teeth inside of frame.

20-128M19"57.50

20-129MReplacement blade (19")10.95



Quality knives since 1890



OPINEL LOCKABLE KNIVES

Manufactured in France. Carbon steel blade with wooden handle complete with lockable ring •Sharp & easy to sharpen!

- 22-037P#7, 3" blade22.00
- 22-038P#8, 3 5/16" blade23.00
- 22-039P#9, 3 1/2" blade25.00
- Sheaths**
- 22-718PFits #7 & #8 Knives38.95
- 22-719PFits #9 Knives44.95



STAINLESS STEEL BLADES

OPINEL LOCKABLE KNIVES (STAINLESS BLADE)

Manufactured in France. Stainless steel blade with wooden handle complete with lockable ring •Sharp & easy to sharpen!

- 22-700P#7, 3" blade22.00
- 22-701P#8, 3 5/16" blade23.00
- 22-702P#9, 3 1/2" blade25.00
- Sheaths**
- 22-718PFits #7 & #8 Knives38.95
- 22-719PFits #9 Knives44.95



KIDS OPINEL LOCKABLE KNIVES

New Rounded point to prevent injury. Manufactured in France. Stainless steel blade with wooden handle complete with lockable ring •Sharp & easy to sharpen!

- 22-707PFuchsia - 3" blade.....25.00
- 22-709P Blue - 3" blade25.00
- 22-710P Red - 3" blade25.00
- 22-708P Natural - 3" blade25.00
- Sheaths**
- 22-718PFits Kids Knives38.95



OPINEL JUNIOR KNIVES

This knife features a round ended tip for added safety around children. The synthetic polymer handle provides a superior grip for smaller hands and features a pea-less safety whistle that works when cold, hot, or wet.

- Blade Length: 3.20"
- Blade Steel: Sandvik 12C27 Stainless Steel
- Overall Length: 7.45"
- Handle Material: Red Polymer
- Weight: 1.3 oz.
- Made in France
- 22-711P#7, 3" blade29.00
- 22-712P#7, 3" blade29.00
- Sheaths**
- 22-718PFits Junior Knives38.95



STAINLESS STEEL BLADES

OPINEL LADIES KNIVES

It is small enough to be placed in a pocket or purse and will "deliver" when needed. Stabilized colored beechwood is ultra-resistant and comfortably contoured to fit the hand. The blade is made from stainless steel, which will not rust.

- Blade Length: 2.875"
- Stainless Steel blade
- Overall Length: 6.5"
- Handle Material: Strawberry Beechwood
- Weight: 1.2 oz.
- Made in France
- 22-715P#6, 3" Blade25.00
- Sheaths**
- 22-718PFits Ladies Knife38.95



COAST BX213 POCKET KNIFE

If you are looking for a super compact pocket knife for your keychain or daily carry, the BX213 Knife is your solution. It has a fiberglass-filled nylon handle for easy grip and a back lock for simplicity and extra safety. Blade Length: 2.5"

- 22-800P16.95



COAST FX220 POCKET KNIFE

Comes equipped with two useful tools, a bottle opener and a money clip. The bottle opener is easy-to-use and can be a valuable tool for work or pleasure. The pocket clip is also specially designed to act as a money clip if needed. The FX220s Frame Lock mechanism keeps the knife secure and the user safe. Stainless steel blade. Blade Length: 2"

- 22-815P16.95



COAST LX305 POCKET KNIFE

With a checkered fiberglass-filled nylon handle with finger grooves carefully placed, the LX305 Knife is the perfect fit for your hand. The knife opens easily and stays open safely with a liner lock. With Coasts commitment to quality, the LX305 Knife is backed by Coasts lifetime warranty against defects in materials and workmanship. Blade Length: 3.25"

- 22-816P19.95



COAST DX440 POCKET KNIFE

The DX440 comes with a checkered fiberglass-filled nylon for all-around utility. Utilizing our Liner Lock technology, anyone can work with confidence knowing that the added safety prevents the knife from accidentally closing. The nylon handle features honeycombed texture that makes for easy cleaning. The knife easily opens with one hand using the thumb studs on the blade, and you can keep it secure with a deep-carry pocket clip. Blade Length: 3.50"

- 22-817P22.95



ACCUSHARP FOLDING SPORT KNIFE

Made of anodized aluminum and stainless steel. Will not Rust. Has patent pending wheel that locks blade open or closed. Also has emergency glass breaker on end of handle. Comes with belt clip.

Approx. Blade Size 2.75" L x 1" W . Overall Length : 7" open

- 22-419R.....Black23.95
- 22-420RCamo.....25.50



ACCUSHARP SPORT KNIFE & SHARPENER COMBO

2-Step Knife Sharpener provides exactly what someone needs to care for and maintain their blades. The Accusharp Folding Sport Knife is constructed of anodized aluminum and stainless steel. With the patent-pending wheel lock, you have the ability to open and close this knife with one hand. Also has a glass breaker feature.

- 22-423R.....31.95



ACCUSHARP SPORT KNIFE & SHARPENER COMBO

Combo includes the classic Accusharp sharpener. The Accusharp Folding Camo Sport Knife is constructed of anodized aluminum and stainless steel. With the patent-pending wheel lock, you have the ability to open and close this knife with one hand. Also has a glass breaker feature.

- 22-421R.....46.95



ROPE KNIFE RKR GH

Craftsman's knife with friction grip and serrated blade that is optimized for cutting through hard or tough surfaces as well as ropes and strapping bands especially where tension to the material is applied. It features a unique function for attaching the holster around a button on your work clothes so that it does not come loose whilst still being easy to remove. The blade is made from 2.0 mm German stainless steel.

- 22-1504M3.6" Blade.....23.95



CRAFTSMAN'S KNIFE HVK

Knife developed and adapted to meet the needs of craftsmen, with a blade made from Japanese knife steel. It features a unique function for attaching the holster around a button on your work clothes so that it does not come loose whilst still being easy to remove. The blade is made from 2.5 mm carbon steel.

- 22-1502M3.6" Blade.....10.95



RESCUE KNIFE OKR GH

Craftsman's knife with friction grip and serrated blade that is optimized for cutting through hard or tough surfaces as well as ropes and strapping band especially where tension to the material is applied, designed with a dull point to minimise sharps injuries. It features a unique function for attaching the holster around a button on your work clothes so that it does not come loose whilst still being easy to remove. The blade is made from 2.0 mm German stainless steel.

- 22-1505M3.5" Blade.....27.95



CRAFTSMAN'S KNIFE RFR GH

Craftsman's knife with friction grip. Developed and adapted to the needs of craftsmen. It features a unique function for attaching the holster around a button on your work clothes so that it does not come loose whilst still being easy to remove. The blade is made from 2.5 mm German stainless steel.

- 22-1506M3.6" Blade.....18.95



OUTDOOR FOLDING KNIFE OKF

Robust folding knife with black coated aluminium, stainless steel parts and a coated black blade in stainless knife steel. A perfect companion in the forest or on the fishing trip. Compact design with a big area of use. Simple and safe locking of the blade with a button on the side of the handle. The belt clip is reversible and can be mounted on both sides of the handle.

- 22-1516M2.75" Blade.....64.00



CHISEL KNIFE STK

Robust knife with V-ground chisel function. It features a unique function for attaching the holster around a button on your work clothes so that it does not come loose whilst still being easy to remove. The blade is made from Japanese knife steel, 3 mm carbon steel.

- 22-1503M2.8" Blade.....15.95



ATTENTION FISHERMAN & PLANT WORKERS!
STEELS FROM ACCUSHARP.



ACCUSHARP SHARPENING STEEL

Fast-sharpening and long-lasting Sharpening Steel will keep all your household knives properly honed. The rubber over-molded handle ensures a secure grip with the collar guard for additional safety. Available in 9 inch and 14 inch.

22-430R.....9"24.95



FILES

- 22-015R.....8" Flat Smooth7.50
- 22-016R.....10" Flat Smooth9.95
- 22-017R.....8" Flat Bastard6.50
- 22-018R.....10" Flat Bastard9.50
- 22-042R.....8" Half Round Bastard.....9.95
- 22-043R.....10" Half Round Bastard.....12.95
- 22-045R.....6" 3-sided Machinest File6.50
- 22-046R.....8" Axe File (11 1/2" Overall)8.95
- 22-080R.....8" Chainsaw File (3/16").....2.95



ACCUSHARP DIAMOND SHARPENING STEEL

Fast-sharpening and long-lasting, the AccuSharp® Diamond Sharpening Steel will keep all your professional knives properly honed. The durable diamond surface quickly returns the edge of a good blade in around 10 strokes. The rubber over-molded handle ensures a safe and secure grip, and the collar guard safely keeps hands out of the way. Available in 9 inch and 14 inch.

22-434R.....9"50.95



SHARPENING STONE

8"x2 1/2"x1 1/4" (2 sides).

22-177R.....3.95



HEAVY DUTY BAIT CHOPPER

Great value! 17 1/2" O.L. length, 12" blade. (Not from Russell.)

22-040R.....29.95



TRAMONTINA 14" HOOK CHOPPER KNIFE

Carbon steel blade. Wooden handle.

22-004M.....14.95



10" DEXTER-RUSSELL STEEL

22-069M.....(Rough).....41.50

22-070M.....(Coarse)35.95

22-071M.....(Smooth)35.95



12" SHARPENING STEEL

Medium grit, plastic handle. (Not Victorinox)

22-001M.....25.95



12" DIAMOND OVAL SHARPENER

22-000M.....49.95



SCALLOP KNIFE

O.L. is 8", 4 3/4" blade. (Not from Russell.)

22-041R.....12.50



TRAMONTINA 10" BUSH KNIFE

Carbon steel blade. Wooden handle.

22-002M.....9.95



2 1/2" ROE KNIFE

Stainless steel blade with plastic handle. Comes with sheath.

22-144M.....46.95

Knives & Sharpeners

COMMERCIAL FISHING GEAR



Accusharp Knife & Tool Sharpener.

Finally a knife sharpener anyone can use. Simple and Easy. Sharpens knives in about 10 seconds with no mess or oils. Sharpening blades are diamond horned tungsten carbide for years of reliable use.



STURDYMOUNT KNIFE SHARPENER

The AccuSharp SturdyMount Knife Sharpener mounts easily to cutting boards, kitchen counters, filet boards, workbenches, butcher blocks, cleaning tables, you name it. No more messy oils or stones.

22-408R.....14.95



AUGERSHARP SHARPENER

The AugerSharp Ice Auger Sharpener is the Ice Fisherman's dream. If you ice fish, you know what work it is when your auger blades are dull. Now you can spend more time fishing and less time drilling holes in the ice.

22-412R.....14.95

ACCUSHARP KNIFE & TOOL SHARPENER

A fast and easy way to sharpen knives, tools and equipment.

22-409R.....White.....14.95

22-410R.....Camo.....20.95



ACCUSHARP PULL-THROUGH KNIFE SHARPENER

This commercial grade knife sharpener combines our diamond-honed tungsten carbide sharpening blades with fine ceramic rods. The heavy duty, ergonomically designed handle with the rubber over-molded grip provides a stable and comfortable platform for sharpening all your knives.

22-438R.....Orange/Green.....30.95



SHEARSHARP / SCISSOR SHARPENER

ShearSharp is an amazing device designed to take the mystery out of sharpening your general purpose scissors, hedge clippers and tin snips.

22-413R.....12.95



ACCUSHARP REPLACEMENT BLADES

These blades fit all of our products except ShearSharp. We use only the finest American Made carbide available, and Diamond Hone to a mirror finish for the best possible sharpening edge. The result is the finest line of carbide sharpeners on the market today at any price. These blades are reversible for double life and most users report an average life of 5-10 years between replacements. Beware of other brands that use cheap imported carbide! Insist on AccuSharp!

22-415R.....9.50



ACCUSHARP DIAMOND PADDLE SHARPENER

This double-sided sharpener features an aggressive coarse diamond grit surface, a fine diamond surface for honing and finishing, and also includes a groove for sharpening hooks and darts. The folding handle allows you to fold and store your sharpener with ease.

22-437R.....40.95



GARDENSHARP TOOL SHARPENER

The GardenSharp Tool Sharpener is designed to sharpen all those single edged, hard to sharpen items in your tool shed, such as lawnmower blades, pruning shears (secateurs), limb loppers, hoes, shovels, scythes.

22-414R.....14.95



ACCUSHARP SHARP'N'EASY

2 step ceramic knife sharpener. Features pre-angled coarse and fine ceramic rods that maintain an accurate edge. Just 3 or 4 strokes across the coarse rods restores the edge, then 3 or 4 strokes across the fine rods finishes and polishes the edge for a smooth sharp finish. Lightweight. Rubber molded grip and feet for safety. Lanyard hole, allows for easy attachment to string or cord. Only 2 1/2" x 2"

22-424R.....6.95



ACCUSHARP DIAMOND PRO 2-STEP KNIFE SHARPENER

Features pre-angled coarse diamond and fine ceramic rods to sharpen, restore, and then polish a blade's edge. The diamond rods are aggressive enough to sharpen all types of blades. The flip side consists of two ceramic rods used to finish and polish the edge for a smooth, sharp finish. The Diamond-PRO 2-Step exterior is made of brushed aluminum and finished with a rubber molded grip and rubber feet for safety.

22-418R.....19.95



ACCUSHARP SHARPENING STEEL

Fast-sharpening and long-lasting Sharpening Steel will keep all your household knives properly honed. The rubber over-molded handle ensures a secure grip with the collar guard for additional safety.

22-430R.....9"24.95



ACCUSHARP DIAMOND ROD SHARPENER

The AccuSharp® Diamond Rod Sharpener is an unbreakable diamond-coated steel rod used to sharpen all kinds of knives, including serrated edges. The retractable rod is engineered with a cone-shaped end for use on serrations and tight spaces. The diamond-coated steel rod also has sharpening grooves for use with all kinds of hooks, darts, and pointed objects and comes complete with a shirt pocket clip for easy storage.

22-403R.....17.50

ACCUSHARP TRI-STONE SHARPENING SYSTEM

This rotating, three-stone system is equipped with coarse diamond, medium alumina-oxide, and fine ceramic stones and an angle guide to assist in maintaining a consistent angle. The base features slip resistant feet, but can also be attached to a work surface if preferred.

22-436R.....71.95



ACCUSHARP DIAMOND SHARPENING STEEL

Fast-sharpening and long-lasting, the AccuSharp® Diamond Sharpening Steel will keep all your professional knives properly honed. The durable diamond surface quickly returns the edge of a good blade in around 10 strokes. The rubber over-molded handle ensures a safe and secure grip, and the collar guard safely keeps hands out of the way. Available in 9 inch and 14 inch.

22-434R.....9"50.95



ACCUSHARP POCKET STONE

Offers traditional sharpening for all kinds of straight-bladed knives. The aggressive cutting feature can sharpen all types of steel. The Stone also comes equipped with a groove to sharpen all varieties of hooks and darts and comes complete with a handy AccuSharp carrying pouch with a built-in belt loop for convenience.

22-405R.....9.95



ACCUSHARP 4-IN-1 KNIFE AND TOOL SHARPENER

Combines every sharpening necessity into one pocket-sized unit. Featuring coarse tungsten carbide sharpening blades and fine ceramic rods, the unit comes with a retractable diamond-tapered rod used for deep serrations. The rod also has a groove for all of your hooks and darts. Plus, the unit comes with a retractable flat diamond stone for users who prefer a continuous surface for their sharpening needs. Molded rubber feet to keep the unit steady while in use.

22-417R.....22.95



ACCUSHARP WHETSTONE/SHARPENER

Includes two sharpening stones for traditional coarse and fine sharpening, plus a convenient bottle of honing solution, all in a single kit. The product features a 3" fine and a 3" medium natural whetstone plus a 1 oz. bottle of superior honing solution. The stones and honing solution stay organized and ready for you each time you need to sharpen your knives and tools.

22-404R.....31.95



Endeavor Gown



Endeavor Apron



Ansell Apron

ENDEAVOR APRONS AND GOWNS

These products surpass the protective standards of PVC, vinyl, neoprene, nitrile, and Hycar. This high quality material is FDA and Agriculture Canada approved. Has a cold flexibility to -65 degrees Fahrenheit. Anti-static, seamless, non-toxic, odorless and non-corrosive.

- 16-446M50" Gown (Blue).....29.95 16-440M 45" Apron (Blue).....10.95

ANSELL ALPHATEC PVC APRONS

Wherever oil, grease and chemicals are present Ansell aprons help workers keep clean and protected from harmful contact. PVC (Vinyl) aprons traditionally offer excellent protection where splashes from acids and caustic bases are a concern. The PVC construction is flexible yet offers resistance to abrasion and puncture. Sealed grommets allow for size adjustment without tear-out. Adjustable ties ensure optimal fit for a wide range of users.

PVC Non-Stitched - 44"

- 16-005RBlue2.19

Ansell



ANSELL TNT DISPOSABLE GLOVES

Durable, 5 mil nitrile gloves. Soft and comfortable. Textured fingers for exceptional grip. Powder free. 100 gloves per box.

- 16-494PSm18.49
 16-495PMed18.49
 16-496PLg18.49
 16-497PXL18.49

NEW



NITRIFORCE DISPOSABLE GLOVES

Latex-free. Weight: 5 Grams. Enhanced tensile strength versus latex or vinyl. Easy to pull on rolled cuff. Medical / Examination Grade (AQL 1.5). 100 gloves per box.

- 16-800PSm14.95
 16-801PMed14.95
 16-802PLg14.95
 16-803PXL14.95

NEW

Ansell



ANSELL MICROFLEX DISPOSABLE GLOVES

MODEL 92-134

Made of a soft nitrile formulation for comfortable fit and feel. Lightweight construction for tactile sensitivity and fine motor control. Designed for a broad range of applications across all industries. Textured on the fingertips for secure handling of tools and materials.

- 16-465PXS16.95
 16-466PSm16.95
 16-467PMed16.95
 16-468PLg16.95
 16-469PXL16.95

NEW



TACTICAL PLUS NITRILE DISPOSABLE GLOVES

Latex-free. Weight: 5.4 Grams. Black colour hides dirt and grease. Enhanced tensile strength versus latex or vinyl. Easy to pull on rolled cuff. Medical / Examination Grade (AQL 1.5) 100 gloves per box.

- 16-805PSm14.95
 16-806PMed14.95
 16-807PLg14.95
 16-808PXL14.95

MERCER'S
 210 MARINE DRIVE, CLARENVILLE, NL
 Visit us online at www.mercersmarine.com
 Our website has Up to Date Pricing & Live Inventory
 TEL: 709.466.7430
 info@mercersmarine.com

GRUNDENS



GRUNDENS BRIGG 26 SLEEVES

These heavy-duty sleeves feature neoprene cuffs to give fishing industry workers the ultimate protection against water, blood, slime and grime. To prevent intrusion at the upper arm, the Brigg 26 features an elastic opening here with an additional hook-and-loop closure. Made from heavyweight 100% impervious PVC-coated cotton material that maintains its flexibility even in frigid temperatures.

18-2157K.....One Size52.95



RANPRO "SL-35-155" 17" SLEEVES

100% waterproof and windproof. Fabric is resistant to all marine and fish oils. Increased tear and wear resistance.

16-302M.....One Size29.95/pr



GLOVE/SLEEVE COMBO

Atlas Model

Shoulder length nitrile. Totally liquid proof. 26" lined rough finish.

16-244P.....Med21.95
 16-245P.....Lg21.95
 16-246P.....XL21.95

GRUNDENS



GRUNDENS BRIS 22 SLEEVES

These lightweight protective sleeves are designed for fishermen, processors and other professionals who need to keep their arms dry and clean while doing messy work. These full-length sleeves are impervious to water, slime, scales and fish oil. Elastic arm and wrist closures protect your arms and clothing against intrusion while comfortably securing the sleeves in place.

18-2156K.....One Size31.95



DISPOSABLE SLEEVES

18" Blue with elastic.

16-980R126.95 (pk/2000)



JACKFIELD GLOVE/SLEEVE

Top quality PVC-Nitrile coating unique in North America. PVC welded cuff. 100% acrylic lining. Pebble palm. Flexible and resistant. Elastic adjustment cord. 28 inches.

16-1222P Lg29.95
 16-1223PXL29.95



JACKFIELD PVC GLOVE/SLEEVE

Triple dipped PVC, fully coated, rough finish. Interlock lining. Heat sealed sleeve with elastic. 28 inches long.

16-1239PSm17.95
 16-1240PMed17.95
 16-1241PLg17.95
 16-1242PXL17.95
 16-1243P2X17.95



ARM SLEEVES

Economy PVC Sleeves

Vinyl, 8 mils, elastic at both ends. Heat sealed.

16-000R.....1.79/pair

Endeavor 19 1/2" Sleeves

Features higher quality at a lower cost. FDA approved. Excellent tear resistance. Anti-static. Resists most chemicals, acids, oils, and fats. Very flexible.

16-449MBlue7.59/pair

MERCER'S
 Phone : 709 466 7430
 www.mercersmarine.com
 Email : info@mercersmarine.com
 Find us on



BOUFFANTS (LATEX FREE)

Bouffant Caps, Disposable soft spunbond polypropylene. Latex Free elastic, hypoallergenic. Sold in bags of 100.

White		
16-960R.....	19"	7.49 (pk/100)
16-962R.....	21"	7.59 (pk/100)
16-964R.....	24"	9.09 (pk/100)
Blue		
16-961R.....	19"	7.49 (pk/100)
16-963R.....	21"	7.59 (pk/100)
16-965R.....	24"	9.09 (pk/100)

NEW



LATEX FREE HOOD/BALACLAVA

The hood offers maximal head protection for workers with long hair or with beards or mustaches. The eye and neck openings have latex free elastics to prevent allergic reactions.

16-983R29.95 / pk of 100



SCOURING PADS

Used extensively in fish plants. #96 medium.

16-220P.....6" x 9". 1.49/ea.



HAIR NETS

Lightweight Mesh Hairnet. Soft chain knit nylon. 1/4" mesh. Priced per quantity of 144. Atlantic Canada's most used hairnet.

16-971R#375, Standard.....51.95 (pk/144)

HAIR NET WITH VISOR

16-969R1.29 /ea.

NEW



DISPOSABLE FACE SHIELD

Made in Canada to help fight COVID19. Sturdy, wrap-around plastic shield constructed from 10 mil-thick PET provides excellent visibility while protecting face and neck. 1" adjustable elasticized head strap holds shield firmly and comfortably in place with silicone grip coating. Added comfort provided by soft, 1" open-cell polyurethane foam-strip along the top edge of the shield. Fits comfortably over glasses and N95 masks.

16-920P8.95



DISPOSABLE SHOE COVERS

SPP shoe cover with Non-slip sole.

16-975RSizes 6 - 10 (Small)..19.95 (pk/100)

16-976RSizes 10 - 13 (Large)..22.95 (pk/100)



DISPOSABLE SHOE COVERS

PE shoe cover. Waterproof.

16-972R.....Sizes 6 - 10.....6.59 (pk/100)

16-973R.....Sizes 10 - 13.....6.59 (pk/100)



BEARD NETS

Beard Guard. Spunbond polypropylene. 1 loop. Disposable.

16-966R.....White9.59 (pk/100)

16-967R.....Blue9.59 (pk/100)



**Shop or Browse
Online 24/7**

at

mercersmarine.com



DISPOSABLE BOOT COVER

PE boot cover. Elastic at top.

16-974R.....Sizes 6 - 11.....15.99 (pk/50)





FISHERS' WHITE GLOVES

Standard type glove used in the commercial fishery. Polyester/nylon blend.

16-007R.....Sm	0.85
16-008R.....Med	0.85
16-009R.....Lg	0.85
16-010R.....XL	0.85



SUREKNIT SPECKLED HEAVYWEIGHT NYLON GLOVES

The new 'FAT' glove provides even more insulation, wear and cushioning than other heavyweights. Nylon is tough, long-wearing and won't get heavy when wet, meaning it will dry faster. You get the benefits of a thicker glove, without taking on more absorption. CFIA approved for food handling.

16-750R.....Sm	0.99
16-751R.....Med	0.99
16-752R.....Lg	0.99
16-753R.....XL	0.99



NEOPRENE GLOVES

16-129P.....Sm / Med - Green	27.50
16-130P.....Lg / XL - Green	27.50
16-131P.....Sm / Med - Black.....	32.95
16-132P.....Lg / XL - Black.....	32.95

Industrial Gloves



THERMO MAXX-GRIP GLOVE

Textured rubber grip over seamless warm cotton knit. Rubber palm for puncture, wear, and liquid protection. Breathable stretch knit wrist and back for comfort. Ideal for cold weather or padded glove applications

16-058R.....Sm	3.49
16-059R.....Med	3.49
16-060R.....Lg	3.49
16-061R.....XL	3.49



GRIPPER GLOVE

The "Gripper" features a PVC criss-cross pattern for added life wear, abrasion resistance and "Sure Grip" Nylon knit is lightweight and comfortable.

16-026P.....	6.95
--------------	------



WORK KING GLOVES Model 761 (White)

Since the beginning of the 20th century "Work King" has become the name to trust in canvas chore gloves. Long lasting quality.

16-064P.....	10.29
--------------	-------



VIKING THERMO JOURNEYMAN

Dual layered protection against cold weather. Stretchy and form fitting design. 15 gauge exterior nylon knit with PVC coating. Very Comfortable.

16-761P.....Med	7.99
16-762P.....Lg	7.99
16-763P.....XL	7.99



COMMERCIAL FISHING GEAR



NORTH SEA WINTER NITRILE COATED GLOVES

Nitrile rubber offers good puncture and abrasion resistance and stands up extremely well to chemicals and oils. Specially formulated to stay flexible in cold conditions, so gloves will not stiffen, crack, or lose their oil-resistant properties even in extreme cold. The full winter-fleece lining cushions hands while keeping them warm and dry.

16-388P.....Med	17.95
16-389P.....Lg	17.95
16-390P.....XL	17.95
16-391P.....2X	17.95



ANSELL ALPHATEC GLOVES

MODEL 87-208
Heavy duty with 0.73 mm / 29 mils thickness. 50% thicker than standard flock lined gloves. Highly resistant to many ketones, salts, detergents, alcohols, alkalis and fats. Excellent resistance to mechanical hazards ,providing increased chemical protection. Chlorinated. 100% cotton flock lining to help absorb perspiration

16-109P.....Sm/7	3.69
16-110P.....Med/8	3.69
16-111P.....Lg/9	3.69
16-112P.....XL/10	3.69
16-113P.....2X/12	3.69



Model 37-501 (Formally model G25B)

Blue Nitrile
Nitrile formula for resistance to oil based chemicals. Flock lined with superior raised diamond grip pattern. Open cuff allows ventilation to keep hands cool. Good puncture resistance.

16-310P.....Sm	3.49
16-311P.....Med	3.49
16-312P.....Lg.....	3.49
16-313P.....XL.....	3.49
16-314P.....2X.....	3.49



SHOWA GLOVE MODEL 600

Wrist length cotton glove with a soft PVC coating. Feel what you touch.

16-171P.....Sm	5.89
16-172P.....Med	5.89
16-173P.....Lg	5.89
16-174P.....XL	5.89



SHOWA GLOVE MODEL 4500

Nitri-Flex Lite is a super-breathable nylon shell. Green, nitrile dipped palm. Seamless nylon liner. Strong abrasion and puncture resistance. Knit wrist. High tactile sensitivity

16-260P.....XS (6)	5.19
16-261P.....Sm (7).....	5.19
16-262P.....Med (8).....	5.19
16-263P.....Lg (9).....	5.19
16-264P.....XL (10)	5.19

SHOP 24/7 FROM THE COMFORT OF YOUR OWN HOME

- Up to date Pricing
- New Products
- Stock Status
- Additional product info
- And more



www.mercersmarine.com



INSULATED NITRI-PRO

Nitrile with triple layer foam insulated liner. This glove is especially popular with people working on fuel delivery trucks and people dealing with fuel.

16-085P.....	10.49
--------------	-------



GLOBE TRADE GLOVES

A good quality, economy PVC glove.

16-115P.....12" model.....	5.49
----------------------------	------



D-FLEX CUT RESISTANT GLOVE

Engineered with HPPE and fiberglass, the SHOWA 8127 cut-resistant glove offers superior cut protection.

•Machine washable •Cut-resistant •Breathable •Form-fitting •HPPE reinforced •Seamless knit •Wire-free liner

16-270P.....Sm	14.29
16-271P.....Med	14.29
16-272P.....Lg	14.29
16-273P.....XL	14.29



SHOWA 257 CUT RESISTANT GLOVE

A 13 gauge lightweight design offers high dexterity, very high cut resistance, and can be laundered multiple times without compromising the glove's cut resistance and performance. The sponge nitrile coating protects against abrasion, snags, and punctures.

16-284P.....Sm	14.59
16-285P.....Med	14.59
16-286P.....Lg	14.59
16-287P.....XL	14.59
16-288P.....2X	14.59



JACKFIELD WATERPROOF THERMAL KNIT GLOVE

13 gauge polyester knit. 100% acrylic 7 gauge thermal lining. Waterproof membrane. Nitrile palm, sandy finish. Elastic cuff 30 cm long. Meets EN 388 (4121xx) and EN 511 (x11) standards. Abrasion resistant, impact protection and waterproof.

16-1230P.....Med	13.49
16-1231P.....Lg	13.49
16-1232P.....XL	13.49
16-1233P.....2X	13.49



JACKFIELD LATEX COATED GLOVE

10 gauge polyester and cotton knit. Latex palm, wrinkle finish. Uncoated knuckles and back for a better dexterity. Elastic cuff.

16-022P.....Sm	4.99
16-023P.....Med	4.99
16-024P.....Lg	4.99
16-025P.....XL	4.99



JACKFIELD PVC GLOVES WITH PEBBLE PALM

Top quality PVC-Nitrile coating unique in North America. Heavy Jersey lining. Pebble palm. Flexible and resistant. 12 inches.

16-1226P.....Lg	14.95
16-1227P.....XL	14.95



JACKFIELD ACRYLIC LINED GLOVE

Double dipped water base PU, fully coated, rough finish. 100% acrylic yellow sherpa lining. 12 inches long.

16-1217P.....Med	27.95
16-1218P.....Lg	27.95
16-1219P.....XL	27.95
16-1220P.....2X	27.95



JACKFIELD THERMAL PVC GLOVE WITH PEBBLE PALM

Top quality PVC-Nitrile coating unique in North America. 100% polyester sherpa lining. Pebble palm. Flexible and resistant. Velcro adjustment on cuff. 12 inches.

16-1236P.....Lg	21.95
16-1237P.....XL	21.95



Soft, Flexible, Showa Gloves



The new standard for comfort, fit and flexibility. Will not stiffen in the cold and allows a "sense of feel" for baiting hooks, processing fish or any required task.



Showa Model 660

Unlined, 12 inch gauntlet regular fit. Used quite often in fishplants for crab processing. Many other uses.

16-175P.....Med	5.99
16-176P.....Lg	5.99
16-177P.....XL	5.99
16-178P.....2X	5.99



Showa Model 620

Unlined, 12" gauntlet regular fit. Our most popular glove.

16-120P Sm	5.99
16-121P Med	5.99
16-122P Lg	5.99
16-123P XL	5.99
16-124P 2X	5.99



HIGHLY RECOMMENDED ITEM

ATLAS TEMRES 282

Warmth, Breathability, and Flexibility have all been combined into a Liquid-Proof glove. The TEMRES provides the wearer with protection from liquids in cold conditions while still allowing them the comfort of a breathable glove. The abrasion-resistant polyurethane coating and insulated acrylic liner were specially designed to retain warmth while reducing perspiration. The thin, yet durable coating maximizes comfort and flexibility in very cold environments. Nitrile was added to the fingertips to increase protection. Launder at 40°C (104°F) using a neutral detergent.

16-265PMed (8).....	29.95
16-266PLg (9).....	29.95
16-267PXL (10).....	29.95
16-268P2X (11).....	29.95



Showa Model 481

Lined 12 inch gauntlet. Similar to model 660 only a little heavier quality with a light fleece lining. Very wear resistant.

16-036P.....Med	9.49
16-037P.....Lg	9.49
16-038P.....XL	9.49



Showa Model 495

Fully coated, extra coating over entire hand. Topstitched edge. Rough finish over entire surface. Antibacterial and anti-odour treatment. Special hydrocarbon treatment.

Anatomical shape. Seamless knit. **Removable acrylic lining. Seals and protects the hand against chemicals while remaining flexible, up to -20°C external temperature**

16-256PMed	22.95
16-257PLg	22.95
16-258PXL	22.95



Showa Model 460

12 inch gauntlet. Lined with seamless, napped acrylic lining. Warm glove for cold conditions. Still retains the sense of touch.

16-040P.....Med	18.95
16-041P.....Lg	18.95
16-042P.....XL	18.95



SHOWA MODEL 377

Offering premium protection against a wide range of chemicals, SHOWA 377 is championed for its ultra-tactile grip and superior durability—enabling you to handle the toughest jobs with ease, even in the most slippery environments. Superior foam over-dip ensures excellent grip even in oily applications. Liquid resistant to end of coated area. Warmth, protection and comfort.

16-275PSm (6).....	8.79
16-276PMed (7).....	8.79
16-277PLg (8).....	8.79
16-278PXL (9).....	8.79
16-279P2X (10).....	8.79



SHOWA MODEL 477 (INSULATED)

Insulated liner protects provide barrier from cold ensuring warmth and comfort all day long. Fully double engineered coating protects against liquids and water penetration. Impermeable for working in damp or greasy environments, keeps your hand dry. Dual nitrile coating technology provides optimal grip longevity. Highly flexible and resistant to abrasion and tearing. Replicates the natural curvature of human hand and so reduces hand fatigue.

16-280PMed (7).....	17.39
16-281PLg (8).....	17.39
16-282PXL (9).....	17.39
16-283P2X (10).....	17.39

Ansell

Great Glove.
Great Value.



ANSELL PRO-FLEX GLOVE (MODEL 4-644) FORMALLY 660

Unlined, 12 inch gauntlet regular fit. Used quite often in fishplants for crab processing. Many other uses.

16-676PMed (8)5.89	16-678PXL (10)5.89
16-677PLg (9)5.89	16-679P2X (11)5.89



JACKFIELD PVC GLOVE

Double dipped PVC, fully coated, rough finish. Jersey lining. 12 inches long. Large cuff

16-1210PXL4.69
----------	---------	-----------



POLAR GRIP GLOVES

Vinyl coated, foam insulated, turn out liner for quick drying. Maximum cold weather protection. 11"

16-191MModel 23-700 (Size 9)20.59
16-158MModel 23-700 (Size 10)20.59



JACKFIELD PVC AND NITRILE GLOVE

Triple dipped PVC and nitrile, fully coated, rough finish. 100% polyester yellow boa lining. 12 inches long

16-1211PSm14.95
16-1212PMed14.95
16-1213PLg14.95
16-1214PXL14.95
16-1215P2X14.95



ANSELL ACTIVARMR Model 97-681

PVC coated flexible nylon exterior even in the coldest temperatures. Protects against liquid and mechanical risks, including cuts. Soft and insulative acrylic interior provides comfort and warmth.

16-506PSm (8)20.95
16-507PMed (9)20.95
16-508PLg (10)20.95
16-509PXL (11)20.95

Ansell



ANSELL POWERFLEX

Model 80-400

Excellent Insulation, Added Grip. PowerFlex Hi Viz Yellow gloves offer high visibility with their yellow thermal terry liner while the bright blue crinkled palm provides added grip. Gloves offer excellent insulation for temperatures as low as -25°C or -13°F. ergonomic design and unmatched comfort. Additional features include excellent wet and dry grip and superior dexterity.

16-290RMed (8)8.99
16-291RLg (9)8.99
16-292RXL (10)8.99
16-293R2X (11)8.99

Ansell



ANSELL ACTIVARMR Model 97-011

2-ply acrylic brushed liner keeps hands warm in extreme cold, as well as cut and abrasion protection. Tested to perform at -4°F/-20°C. ¾ double-dipped nitrile coating has a sandy finish for excellent wet/oily and dry materials handling. Superior all-day comfort reduces hand fatigue. More breathable than leather, keeping hands dry and comfortable. Increases worker safety when high visibility is a must.

16-498PSm (8)10.69
16-499PMed (9)10.69
16-500PLg (10)10.69
16-501PXL (11)10.69

Ansell



ANSELL VERSATOUGH

Model 23-202

Good dexterity and pliability at low temperatures. Inner polar acrylic seamless liner, gauge 13. Soft integral PVC coating. Roughened sandblast finish on the glove and smooth finish on the cuff. Designed to protect at temperatures down to -30°C. 21 CFR (USA) and European Directive compliant for food applications. VersaTouch 23-202 was previously known as the P56B Insulator

16-318PMed (8)14.29
16-319PLg (9)14.29
16-320PXL (10)14.29

www.mercersmarine.com

- Always Open
- Safe & Feature Items
- View Catalogue
- Thousands of products
- Updated Regularly
- Up to date Pricing
- Mobile Friendly
- Shop from anywhere at anytime

Also find us on



ENDURA WORK GLOVES UNLINED

Endura fitters gloves stand up to heavy-duty rugged wear. They provide excellent protection from cuts, scrapes and abrasions because of the smooth top grain cowhide from which they are made. Oil and water resistance. Elastic backs also ensure a snug fit.

- 16-737POne Size-Unlined (Model 76BUL)6.95
- 16-738POne Size-Lined (Model 76B)6.95
- 16-743P...One Size-BOA Lined (Model 76BOA)12.49



ENDURA AMERICAN DRIVER GLOVE

Endura® cowhide gloves provide comfortable, dependable hand protection. They are naturally durable, offer good dexterity and water repellency. Driver styles provide a snug fit and a good sense of touch. Available in lined and unlined.

Unlined	Lined
16-396PSm	16-400PSm
16-397PMed	16-401PMed
16-398PLg	16-402PLg
16-399PXL	16-403PXL
16-395P2X	

Unlined 7.95 Lined 8.95



HI-VIZ FITTER'S COWGRAIN GLOVE

One-piece palm. Reflective. Inside elastic, rubberized cuff.

- 16-1000P Orange (Lg)9.29



INSULATED FITTERS COWGRAIN GLOVE

One-piece palm. Fully fleece lined. Knit cuff.

- 16-086POne Size 12.49



LEATHER "SHUCKS"

LINED MODEL

Removable BOA liner.

12-584PMed	46.95
12-585PLg	46.95
12-586PXL	46.95
12-587P2X	46.95

UNLINED MODEL

12-581PLg	29.95
12-582PXL	29.95
12-583P2X	29.95



ONE FINGER LEATHER "SHUCK"

12-588PLg	27.95
12-589PXL	27.95
12-590P2X	27.95



TOUGH-DUCK WORK GLOVE

10 oz. cotton brown twill. Palm lined. Premium cowhide. Rubberized safety cuff. Leather knuckle strap and finger tips.

13-7874MMed	19.95
13-7875MLg	19.95
13-7876MXL	19.95
13-7877M2X	19.95



ENDURA WINTER LINED WORK GLOVE

Endura winter-weight fitter features smooth heavy-weight cowgrain leather for durability and good oil and water resistance. Gunn-custyling features leather fingertips, index finger and knuckle strap to protect against scrapes and abrasions. Cotton backs are elasticized for snug fit. Protective safety cuff for easy on and off. Full acrylic BOA lining for optimal warmth.

Model 76 BOA

- 16-743POne Size 12.49



ENDURA WINTER LINED GLOVE

Brushed jersey-fleece interior lined with 100g Thinsulate for winter protection in temperatures down to -15°C / 5°F. High tensile strength goatskin provides outstanding abrasion resistance. Cut-and-sewn construction combined with elasticized backs provide an optimal, comfortable fit.

16-412PXS	14.95
16-413PSm	14.95
16-414PMed	14.95
16-415PLg	14.95
16-416PXL	14.95
16-417P2X	14.95



DELUXE 5 FINGER LINEMAN GLOVE (6" CUFF)

These deluxe gloves are made with heavyweight 3.5oz grain horse hide leather which is treated with WaterStop to give the leather water, oil and stain resistant quality. Performance thumb/palm patch which reinforces particular areas. 3M scotchlite reflective striping for night time visibility. All gloves sewn with "Kevlar" thread.

Unlined (Model 365DLX6)

16-718M.....Med	32.95
16-719M.....Lg.....	32.95
16-720M.....XL.....	32.95

Lined (Model 365DLXFTL)

Same as above but hand features fully "Thinsulate C100" lining.

16-714M.....Med	39.95
16-715M.....Lg.....	39.95
16-716M.....XL.....	39.95

DELUXE 5 FINGER LINEMAN GLOVE (2" CUFF)

These deluxe gloves are made with heavyweight 3.5oz grain horse hide leather which is treated with WaterStop to give the leather water, oil and stain resistant quality. Performance thumb/palm patch which reinforces particular areas. 3M scotchlite reflective striping for night time visibility. All gloves sewn with "Kevlar" thread. This glove is very popular with A.T.V. users.

Unlined (Model 365DLX2)

16-730M.....Med	32.95
16-731M.....Lg.....	32.95
16-732M.....XL.....	32.95

Lined (Model 365DLX2TL)

Same as above but hand features fully "Thinsulate C100" lining.

16-734M.....Med	39.95
16-735M.....Lg.....	39.95
16-736M.....XL.....	39.95

DELUXE 1 FINGER LINEMAN MITT (6" CUFF)

These deluxe mitts are made with heavyweight 3.5oz grain horse hide leather which is treated with WaterStop to give the leather water, oil and stain resistant quality. Performance thumb/palm patch which reinforces particular areas. 3M scotchlite reflective striping for night time visibility. All mitts sewn with "Kevlar" thread.

Unlined (Model 361DLX6)

16-710M.....Med	32.95
16-711M.....Lg.....	32.95
16-712M.....XL.....	32.95

Lined/Thinsulate (Model 361DLXFTL)

Same as above but hand features fully "Thinsulate C100" lining.

16-706M.....Med	39.95
16-707M.....Lg.....	39.95
16-708M.....XL.....	39.95

Lined with "Removeable Liner" (Model 361DLXWL)

Same as above but hand features fully "Thinsulate C100" lining.

16-701M.....Med	41.95
16-702M.....Lg.....	41.95
16-703M.....XL.....	41.95



PIONEER COWGRAIN WORK GLOVE

One-piece palm. Inside elastic, rubberized cuff.

16-1006P.....One Size	7.79
-----------------------------	------



JACKFIELD LEATHER WORK GLOVE

One piece palm. Cow grain leather A grade. Yellow with blue stripes cotton back. Safety cuff.

Unlined Model

16-1201P.....Lg.....	7.29
16-1202P.....XL.....	7.29
16-1203P.....2X.....	7.29



ENDURA CHAINSAW GLOVES

See page 344 for more info.

16-019M.....Med	43.95/pr.
16-020M.....Lg.....	43.95/pr.
16-021M.....XL.....	43.95/pr.



"LITTLE KIDS" WORK GLOVES

Just like mom & dad's! Kid's love this item. Cowgrain leather.

16-070M.....Sm	9.29
16-071M.....Med	9.29



Marine Equipment





POWER STEERING HELMS

The helms have various displacement to control the amount of turns from full port to full starboard. They come with internal check and by-pass valves to prevent kick-back from the wheel. Fluid is by-passed internally to protect your steering system. 1/2" ORB ports.

44-1475K	9.7 cu.in.....	630.00
44-1478K	14.0 cu.in.....	675.00



PARKER POWER STEERING PUMPS

Exceptionally compact and lightweight for their capacity, these fixed displacement gear pumps from Parker are a great choice for a hydraulic power steering system. Featuring built-in flow control set at 5 GPM, and integral pressure relief at 1000 psi. 1.178 cu. in. displacement. Maximum speed 4000 rpm, maximum pressure 2500 psi. Inlet port - 1" SAE straight thread ORB. Outlet port - 1/2" SAE straight thread ORB. To be used with a pump mount bracket or bolted directly to engine.

3/4" keyed shaft. SAE - "A" 2-bolt mount.

44-1297K	Counter clockwise.....	1055.00
44-1298K	Clockwise	1055.00

5/8" 9-tooth spline shaft. SAE - "A" 2-bolt

44-1300K	Counter clockwise.....	1055.00
44-1301K.....	Clockwise	1055.00

3/4" 11-tooth spline shaft. SAE - "A" 2-bolt

44-1302K	Counter clockwise.....	1150.00
44-1303K.....	Clockwise	1150.00

Seal kit

44-1312K.....		289.00
---------------	--	--------



SEASTAR POWER ASSIST STEERING SYSTEM

SeaStar Power Assist steering brings automotive-type steering comfort and control to powerboats. The addition of a Power Assist unit will greatly reduce steering effort and enhance the boating experience for everyone. The SeaStar Power Assist steering unit is designed for use with SeaStar manual hydraulic steering systems and is suited for all heavy / high torque steering applications. (See diagram below)

Features

- Dramatically reduces wheel torque
- Easy to install
- Simple 'add on' to an existing SeaStar manual system (optimal performance achieved when used with SeaStar 1.4 – 2.0 pumps)
- OEM or Retro fit
- Compatible with power purge system
- Reverts to manual mode in the case of power loss.
- Suitable for use with autopilots
- 12v or 24v operation
- Wall or floor mounted
- 15' Wiring harness, and mounting bracket included
- Ignition protected (SAE J-1171)
- ABYC, CE, NMMA, ISO 10592 Approved

42-776K.....	Model PA-1200-2.....	P.O.R.
--------------	----------------------	--------



STEERING COLUMNS

Stainless steel steering column with "oilite" bearing and stainless steel acorn nut.

44-985K	5" diameter.....	614.00
44-965K	7" diameter.....	640.00

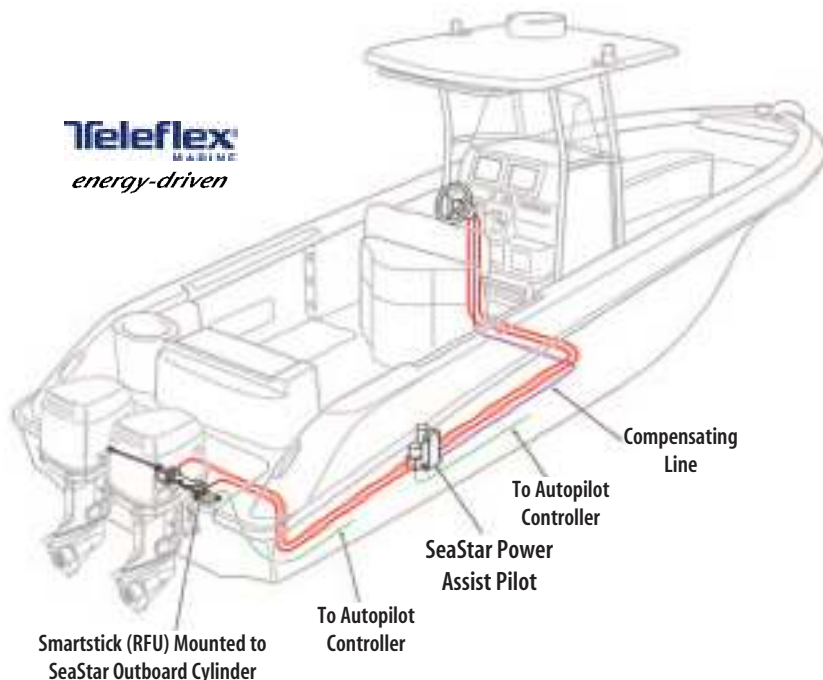

Teleflex
MARINE
energy-driven

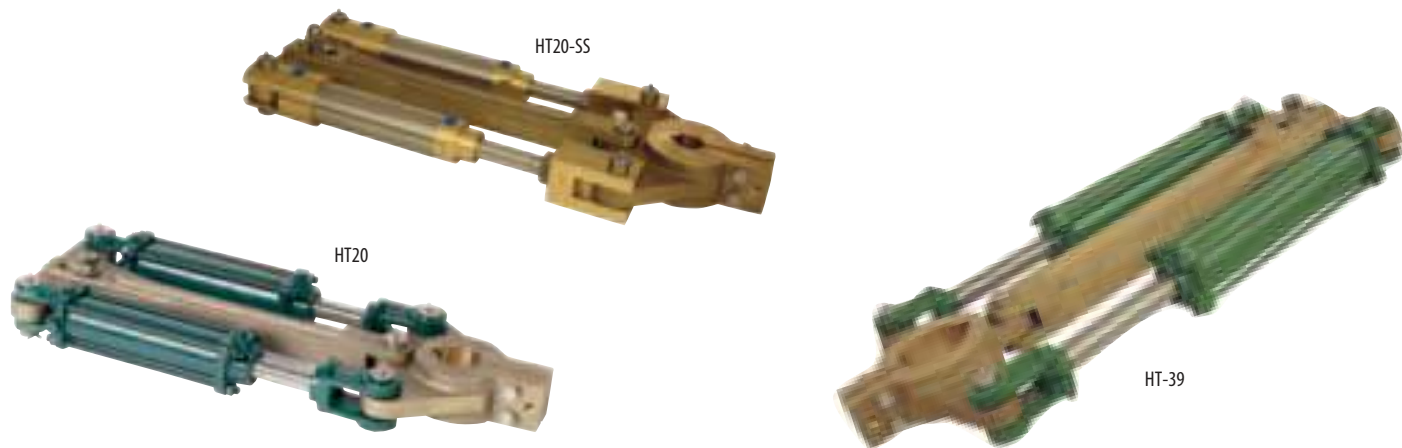

DUAL CYLINDER HYDRAULIC POWER STEERING SYSTEMS

Hydraulic power steering systems offering 20,200 in.-lb. of rudder torque and 45 degrees of rudder in each direction. 3.3 turns of the wheel lock-to-lock. Suitable for most boats up to 65 ft. Rugged, oversized construction for high strength and long life. Painted steel cylinder barrels and clevises, stainless steel cylinder rods, manganese bronze tiller arm, quadrant frame and mount, stainless steel clevis pins and fastenings, glass filled teflon sliding bearing.

Contact Mercer's Marine for information on your specific application.

HT20 QUADRANT ASSEMBLY

Complete assembly consisting of dual cylinders with stainless steel cylinder rods mounted on a durable corrosion resistant quadrant. Complete with mount and tiller arm bored for rudder shafts ranging from 1 1/2" – 2 1/2".

44-978K.....	1 1/2"	3545.00
44-979K.....	1 3/4"	3545.00
44-980K.....	2"	3545.00
44-981K.....	2 1/4"	3545.00
44-982K.....	2 1/2"	3545.00

Replacement parts

44-986K.....	Quadrant frame	975.00
44-987K.....	Quadrant mount	267.00
44-988K.....	Slide Bearing.....	32.50
44-989K.....	Clevis pin (3 1/4").....	51.95
44-949K.....	Clevis pin (2 7/8").....	49.50
44-990K.....	Cylinder	360.00
44-964K.....	Cylinder, stainless steel.....	950.00

HT20-SS QUADRANT ASSEMBLY

Now available corrosion resistant stainless steel and brass cylinders. With proper installation and maintenance, this system will outlast your boat.

44-1140K.....	1 1/2"	4740.00
44-1141K.....	1 3/4"	4740.00
44-1142K.....	2"	4740.00
44-1143K.....	2 1/4"	4740.00
44-1144K.....	2 1/2"	4740.00

44-991K.....	Cylinder seal kit.....	55.00
44-992K.....	1 1/2" tiller arm	1285.00
44-993K.....	1 3/4" tiller arm	1285.00
44-994K.....	2" tiller arm	1285.00
44-995K.....	2 1/4" tiller arm	1285.00
44-996K.....	2 1/2" tiller arm	1285.00

HT39 QUADRANT ASSEMBLY

Serious offshore-capable equipment for the most demanding fishing and workboat applications. Offering 39,000 in. -lb. of rudder torque and 45 degrees of rudder in each direction. 3.2 turns of the wheel lock-to-lock. Components are overbuilt for strength and durability. Painted steel cylinders are upgraded with stainless steel piston rods. Manganese bronze castings, stainless steel clevis pins and fastenings, glass filled teflon sliding bearing, add up to quality and performance.

Complete assembly consisting of dual cylinders with stainless steel cylinder rods mounted on a durable corrosion resistant quadrant bored for rudder shafts ranging from 2 1/2" – 3 1/2".

44-1150K.....	2 1/2"	6459.00
44-1151K.....	2 3/4"	6459.00
44-1152K.....	3"	6459.00
44-1153K.....	3 1/2"	6459.00

Replacement parts

44-1160K.....	Quadrant frame	2350.00
44-1161K.....	Quadrant mount	371.00
44-1162K.....	Slide Bearing.....	55.75
44-989K.....	Clevis pin (3 1/4").....	51.95
44-1163K.....	Cylinder	415.00
44-1164K.....	Cylinder seal kit.....	75.00
44-1165K.....	2 1/2" tiller arm	2450.00
44-1166K.....	2 3/4" tiller arm	2450.00
44-1167K.....	3" tiller arm	2450.00
44-1168K.....	3 1/2" tiller arm	2450.00



SINGLE CYLINDER HYDRAULIC POWER STEERING SYSTEM

Complete assembly consisting of a single cylinder with stainless steel cylinder rod, bronze tiller arm and cylinder mount, suitable for most boats up to 45 ft. Offering 45 degrees of rudder in each direction. Solid bronze tiller arm and bronze cylinder mount. Tiller arms are bored for rudder shafts ranging from 1 1/4" - 2". No steel bushings to rust, seize or crack. Clevis pins are stainless steel and complete with grease grooves and stainless steel grease fittings. All fasteners are stainless steel.

44-1314K.....	1 1/4"	1650.00
44-1315K.....	1 1/2"	1650.00
44-1316K.....	1 3/4"	1650.00
44-1317K.....	2"	1650.00

44-1320K.....	Cylinder mount.....	320.00
44-989K.....	Clevis pin (3 1/4").....	51.95
44-1321K.....	Cylinder	415.00
44-991K.....	Cylinder, seal kit.....	55.00
44-1322K.....	1 1/4" tiller arm	855.00
44-1323K.....	1 1/2" tiller arm	855.00
44-1324K.....	1 3/4" tiller arm	855.00
44-1325K.....	2" tiller arm	855.00

Capilano

Teleflex Hydraulic steering systems are Atlantic Canada's first choice.

It is essential that a correct matching of helms, rams and other related products be achieved for maximum performance and safety. Give us the information and our staff will recommend the correct match for your boat.



SEASTAR CAPILANO HELM PUMPS

The SEASTAR/CAPILANO series of helm pumps allow the user the freedom to adjust the number of turns required from hard over to hard over, thus allowing the operator to react to different weather conditions and maneuvering requirements. Both pumps have port size of 3/8" NPT.

1250v Helm Pump (HH5250)		
42-021K.....	1.7 to 3.4 cu.in.....	2045.00
1275v Helm Pump (HH5275)		
42-022K.....	2.7 to 5.4 cu.in.....	2195.00

Replacement Parts for 1250 & 1275

42-252P.....	Seal Kit (HS5161).....	86.00
42-320P.....	Dip Stick / Filler.....	9.95
42-306P.....	Shaft Lock Nut.....	18.95
42-314P.....	Shaft Key.....	19.95

SEASTAR / CAPILANO CYLINDERS

These cylinders are constructed of stainless and bronze and have adjustment tilt capability on base mounting plate for alignment. Bleeder tees are located on top of the cylinder to allow for easy removal of air locks. We supply these cylinders with "Clevis Ends" but ball joint ends may be provided if required. Inquire

BA175-7 TM Cylinder		
42-079K.....	HC5319.....	1299.00
BA200-7 TMC Cylinder		
42-025K.....	HC5357.....	1750.00
BA-200-11 Cylinder		
42-346K.....	HC5379.....	1950.00
SEAL KITS FOR ABOVE		
42-253P.....	HS5182 for BA150 7TMC.....	93.00
42-254P.....	HS5183 for BA175 7TMC.....	102.00
42-255P.....	HS5184 for BA200 7TMC.....	105.00
42-347P.....	HS5185 for BA200 11TMC.....	101.00

CAPILANO 1250V / 1275V SYSTEM
(DUAL STATION SHOWN)

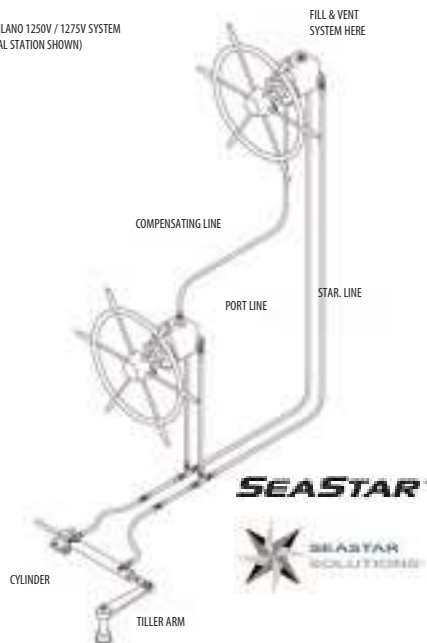

COPPER TUBING

This soft copper tubing is heavy walled refrigeration type. The only one that should be used.

42-036M.....	3/8" x 50'.....	152.95
42-038M.....	1/2" x 50'.....	174.95



TILLER ARMS

Bolt and keyway style.

Manganese Bronze		
42-800M.....	1 1/4" Bore x 9 1/2".....	175.00
42-802M.....	1 1/2" Bore x 15 3/4".....	365.00
42-803M.....	1 3/4" Bore x 15 3/4".....	330.00
42-804M.....	2" Bore x 15 3/4".....	482.00
42-805M.....	2 1/4" Bore x 17".....	439.00

SEASTAR HELM PUMPS

Helm rotor supported by three roller bearings for durability. Ball bearing piston race for smooth operation. Easily replaceable shaft seal for fast field repair. 1/4" NPT ports. Built-in lock valve for positive rudder lock, no extra plumbing. Patented bleed tubes make bleeding the helm a snap. Internal air pocket eliminates oil expansion overflow. Integral relief valve.



SEASTAR 1 "FRONT MOUNT" HELM PUMP

Compact, stylish design. 1.7 cubic inch displacements. Convenient front of dash fill. Small 3.0" hole cutout on dash. Complete with elbow fittings and ORB to NPT. For light displacement boats up to approx. 30'.
42-441K HH5271-3 945.00



SEASTAR 1 "TILT MOUNT" HELM PUMP

5 wheel positions allow adjustment to most comfortable steering position. 48 degree tilt range (18 down - 30 up). 1.7 cubic inch displacements. Convenient front of dash fill. Complete with elbow fittings. For light displacement boats up to approx. 30'.
42-033K HH6541-3 1485.00



BAYSTAR "FRONT MOUNT" HYDRAULIC STEERING HELM

Super low friction, fixed displacement helm pump from the world's foremost manufacturer of manual hydraulic steering systems. Provides 4 1/2" turns lock-to-lock when used with Baystar outboard cylinder. Suitable for use on outboard installations up to 150HP. Requires a 3" diameter cut-out. 1/4" NPT ports. 3/4" standard taper shaft.

42-620K HH4314 620.00



SEASTAR 1 "REAR MOUNT" HELM PUMP

Behind dash mounting configuration. 1.7 cubic inch displacements. Top of dash fill point. Complete with elbow fittings. For light displacement boats up to approx. 30'.
42-032K HH5261-3 1075.00



SEASTAR 1 "PRO-TILT MOUNT" HELM PUMP

Pre loaded dual taper bearings ensures minimal excess free play. Smooth operation and feel. Shaft seals to prevent water ingress. 48 degrees of tilt articulation. 5 positive lock positions. Compact footprint. Maintenance free. Fits most styled and formed dashes. For light displacement boats up to approx. 30'.
42-438K HH6489-3 1550.00



BAYSTAR "TILT" HYDRAULIC STEERING HELM

BayStar allows you to install all of the safety, reliability and comfort of hydraulic steering onto your boats rated to a MAXIMUM of 150 HP (total). Displacement: 1.4 cu inch. Shaft: 1/2" threaded. Mounts:(3) 3/16" diameter holes. Cutout: 3" diameter. Designed for smaller outboards. 4.5 turns from lock-to lock. Super low friction helm for smooth comfortable steering.

42-621K HH4315 995.00



SEASTAR 2 HELM PUMP

Specifically designed to be used on smaller fishing vessels involved in the Lobster and Crabbing Industries. The Commercial Helm Pumps are designed with a stainless steel shaft and heavy duty shaft seal and wiper. This new shaft and seal help protect the Helm Pump from the abrasive effects of sediment that is brought on board by the operator handling Traps or Pots. 2.4 cu.in. displacement. For light displacement boats up to approx. 36'.
42-442K HH5224 Commercial 1275.00

2.4 cu.in. displacement. For light displacement boats up to approx. 36'.
42-440K HH5272 Front Mount 1075.00



Replacement Helm Nut Kit

Includes nut, key, shaft seal, and seal plate.
42-306P HP-6032 18.95



SEASTAR OIL

For use with SeaStar I & II Systems. 1 litre.
42-029K 31.50

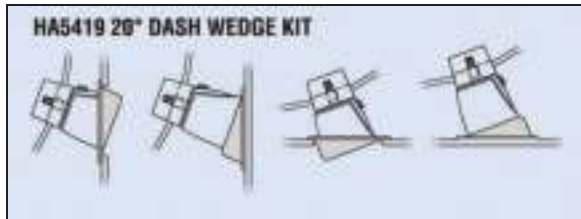

20° Wedge Kit

This kit is designed to mount the helm at a 20° angle to the mounting surface. 4 possible mounting configurations are available.
42-351K HA5419 129.95

SEASTAR



FRONT MOUNT

SIDE MOUNT

INBOARD

SEASTAR FRONT MOUNT "OUTBOARD" CYLINDERS

Single and multiple non-power-assisted outboard engine applications up to 350 hp for singles (700 hp for counter-rotating twins). Patented "Pivot" design allows independent engine tilt in dual engine installations. Suitable for speeds up to 60 mph and dual station use.

42-321K	HC5345	1090.00
42-452K	HC5347	1220.00
42-461K	HC5348	1220.00
42-471K	HC5358	1125.00

SEAL KIT

42-458P	HS5167	202.00
---------------	--------------	--------

SEASTAR SIDE MOUNT "OUTBOARD" CYLINDERS

Unbalanced cylinder with 4.8/5.7 turns lock to lock. Suitable for installation in shallow splashwells. Single and dual non-power assisted outboard engines up to 300hp that have standard engine tilt tube. Suitable for speeds up to 60 mph and dual station use.

42-027K	HC5370	820.00
SEAL KIT		
42-258P	HS5153	96.00

SEASTAR INBOARD CYLINDERS

Anodized aluminum construction. Suitable for single or dual engine applications. O-ring ports with bleeder fitting.

BA150-7ATM Cylinder

42-015K	HC5314	1020.00
SEAL KIT		
42-312P	HS5156	73.00

BA175-7TM Cylinder

42-079K	HC5319	1299.00
---------------	--------------	---------

SEASTAR



SEASTAR NYLON TUBING

Non-corrosive tubing designed for use on SeaStar I Steering Systems. Fits hardware supplied with SeaStar I cylinders. Not suitable for use with SeaStar II Systems.

42-030K	3/8" x 50' coil	168.00
---------------	-----------------------	--------

SEASTAR



BAYSTAR HYDRAULIC FRONT MOUNT CYLINDER

Compact, front mount, balanced cylinder for use with the Baystar helm pump on single outboard installations up to 150HP. Fits most splashwells 32" or more in width. Complete with bleeder tees installed in both ports.

42-622K	HC-4645H	725.00
42-623K	HC-4647H	725.00
42-624K	HC-4648H	725.00
42-625K	HC-4658H	725.00

SEASTAR

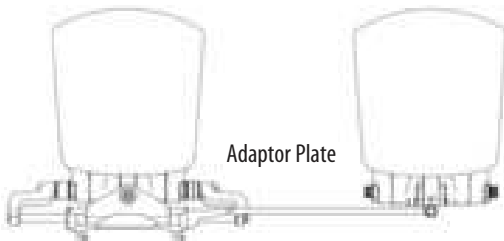

Adaptor Plate



Tie Bar

ENGINE TIE BARS

For installation of two O/B motors, a tie bar and adaptor plate kit are normally required. Contact us with your engine type, horsepower and model year.

Engine Tie Bar Kits

42-341K	HO-6001	735.00
42-342K	HO-6002	785.00
42-344K	HO-6003	745.00

Universal Tie Bars

(No Adaptor Plates)

42-304K	HO-5009	485.00
---------------	---------------	--------

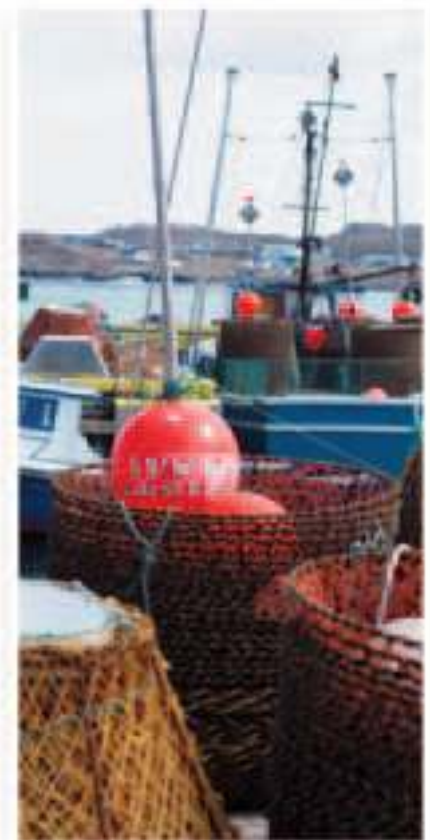



SEASTAR



SEASTAR OUTBOARD STEERING KIT

Single and dual non-power assisted outboard systems. Allows independent engine tilt in dual engine applications. Rated to 60 mph. Rated for single outboards up to 300 hp or twin engines up to 600 hp. 5 turns lock to lock.

Kit Includes:

SeaStar Helm HH5271, Front Mount Cylinder HC5345, 2 L SeaStar Oil

42-045K.....HK6400A..... 2066.50



SEASTAR



SEASTAR OUTBOARD STEERING KIT- YAMAHA

For use with single engine up to 350 hp. Rated to 60 mph. 5 turns lock to lock.

Kit Includes:

SeaStar Helm HH5271, Front Mount Cylinder HC5358, & 2 L SeaStar Oil

42-047K.....HK6500Y..... 2133.00



SEASTAR



SEASTAR SIDE MOUNT STEERING KIT

Single and dual non-power assisted outboard engines up to 300hp that have standard engine tilt tube. Rated to 60 mph. 4.8/5.7 turns lock to lock.

Kit Includes:

SeaStar Helm HH5271, Front Mount Cylinder HC5370, & 2 L SeaStar Oil

42-049K..... 1828.00



SEASTAR



SEASTAR CLASSIC TILT STEERING KIT

For use with single engine up to 350 hp. Rated to 60 mph. 5 turns lock to lock.

Kit Includes:

SeaStar Helm HH6541, Front Mount Cylinder HC5345, & 2 L SeaStar Oil

42-051K.....HK6400TC..... 2638.00



STERNFLEX RIGGING HOSE & FLANGE

Shields sternflex has a polyethylene co-polymer wall with a integral polyeththlene helix. This hose is used as a protective cover for the harness, hoses and cables on outboard mounted engines. 2" ID tubing.

42-278R.....Rigging Flange..... 13.95
42-279R.....2" Rigging Hose.....5.19/ft.



SEASTAR

HYDRAULIC HOSE KITS

- 42-183K2 Hoses, 14' long.....196.00
- 42-184K2 Hoses, 16' long.....212.00
- 42-185K2 Hoses, 18' long.....230.00
- 42-186K2 Hoses, 20' long.....248.00
- 42-187K2 Hoses, 22' long.....278.00
- 42-188K2 Hoses, 24' long.....294.00
- 42-189K2 Hoses, 26' long.....348.00
- 42-191K2 Hoses, 30' long.....389.00
- 42-192K2 Hoses, 34' long.....489.00



SEASTAR
BAYSTAR

BAYSTAR HYDRAULIC FRONT MOUNT STEERING SYSTEM

"Baystar" hydraulic steering is brought to you by the manufacturers of SeaStar. The BayStar system allows the boater to install all the safety, reliability and comfort of a hydraulic steering system on boats "rated to 150 H.P." This is a single engine system only and is not designed for commercial use. Fits most engines from 1990 to date.

Kit includes: BayStar helm, BayStar front mount cylinder with linkage arm, fittings, 2 litres of oil and 2 x 20' pieces of tubing which can be cut to desired length.

42-610K.....HK-4200A..... 1350.00



SEASTAR

HYDRAULIC "BULKHEAD" HOSE KITS

- 42-265K2 Hoses, 14' long.....315.00
- 42-266K2 Hoses, 16' long.....328.00
- 42-267K2 Hoses, 18' long.....349.00
- 42-268K2 Hoses, 20' long.....368.00
- 42-269K2 Hoses, 22' long.....389.00
- 42-270K2 Hoses, 24' long.....408.00
- 42-271K2 Hoses, 26' long.....429.00
- 42-273K2 Hoses, 30' long.....464.00



ELECTRIC TRIM TAB SYSTEMS

Lenco Electric Trim Tab Kits make your boat ride smoother, drier, faster and with increased safety. The Lenco ballscrew design is more reliable, three times more powerful and features an instant response, which makes them very user friendly compared to typical hydraulic systems. 12V -high torque, 5 amp motors are completely enclosed within a high impact UV resistant cylinder case. Lenco fast response electric actuators are fully submersible with all plug & play waterproof Deutsch connections. Trim Tab blades are 12 Gauge - 304 SS with a 5/8" flared trailing edge and 1/8" diameter hinge pin. Kits include standard actuators with 5/16" SS bolts. **Please Note : Switches Sold Separately**

- For Boats 14' to 18'**
42-580P9" x 9"975.00
- For Boats 16' to 25'**
42-581P9" x 12"995.00
- For Boats 22' to 30'**
42-582P9" x 18"1075.00
- For Boats 26' to 40'**
42-583P9" x 24"1250.00
- For Boats 30' to 50'**
42-584P9" x 30"1395.00
- Replacement Actuators**
42-595P12V375.00
42-596P24V450.00



LENCO EXTENSION CABLES

- Deutsch Connected Actuator Extension Harness
42-597P7 ft42.95
42-598P14 ft49.95



LED INDICATOR SWITCH KIT

The switch itself is completely waterproof, and has an over-molded connector to eliminate water intrusion. L.E.D. indicator lights let you know exactly where your trim tabs are at all times. A backlit keypad automatically illuminates graphics for night viewing.

- Kit Contents : •Self-contained sealed Key Pad •Control box •36" Power Pigtail.
42-591P12/24V595.00



STANDARD SWITCH KIT

- The switch itself is completely waterproof, and has an over-molded connector to eliminate water intrusion.
Kit Contents : •Key Pad •Control Box •36" Power Pigtail.
42-590P12V349.00



DOUBLE ROCKER SWITCH KIT

- Kit Contents : •#122 Carling Double Rocker Switch
•Deutsch Connectors •36" Power Pigtail.
•Installation hardware included.
42-592P12/24V158.00



LENCO GLAND SEAL KIT

- Allows you to route the actuator wires through the transom above or below the waterline.
42-594P34.95



HYDROFOIL STABILIZERS

Eliminates bow rise, cavitation and prop blow-out. Significantly improves planing time, top speed, handling and safety. For all outboards and stern drive boats from 25 to 365 H.P. Easy installation. •StingRay Jr. is for smaller engines (from 1 1/2-40hp)

- 42-296MClassic114.95
Junior (For smaller engines 1.5-40hp)
42-298MJunior84.95



STARFIRE HYDROFOIL

- Gets boats on plane quicker. Keeps boats on plane at lower speeds. Improves holeshots. Maximizes stabilization. Saves fuel. Promotes safety by increasing visibility at lower speeds. Reduces chinewalking, porpoising, cavitation, and ventilation.
42-299M142.95



RETROFIT KIT FOR BENNETT TRIM TABS

Bennett Hydraulic-to-Lenco Electric Conversion and Performance Upgrade Kit. The simple Bennett RetroFit Kits include everything necessary to upgrade your current boat without drilling or filling. You simply discard the hydraulic pump unit and the two Bennett cylinders. Connect the new actuator wiring to the existing harness (jumper wires are included for attaching to current switch). Complete installation instructions are included.

- 42-587P12V599.00

SEASTAR



NFB SAFETY 4.2 STEERING HELM

The NFB 4.2 is a "No Feedback" helm for about the cost of an old fashioned steering replacement helm •Designed for boats up to 24', the NFB 4.2 makes steering easier than ever with smooth, responsive control •Rated for V-6 and smaller outboard engines, subject to speed / horsepower limitations •3/4" standard tapered shaft •Steering wheels up to 16" diameter.

42-476R.....SH-4910P295.00

SEASTAR



BIG-T STEERING HELM

The original Teleflex steering system! Designed for use with inboards to 34' with 1 or 2 engines, using single or dual stations, subject to speed / horsepower limitations. 3/4" standard tapered shaft (steering wheels up to 20" diameter).

42-041R.....SH-5000P399.95

SEASTAR



SAFE-T QC STEERING HELM

World's largest selling mechanical steering system! •Patented quick connect cable makes installation a snap •For boats up to 24' subject to horsepower / speed limitations •Standard 3/4" tapered shaft, for wheels up to 16" diameter.

42-134R.....SH-5094P169.00



BIG-T BEZEL

2 piece bezel allows for mounting at 90° or 20°.

42-054R.....285.00



SAFE-T HELM BEZELS

42-053R.....90°46.50

42-121R.....20°62.50



NFB SAFE-T 4.2 BEZELS

42-477R.....90°55.95

42-121R.....20°62.50

NEW



CABLE BOOT

Made of PVC. Size: 4.72"(Dia.)/ 2.75"(Dia.) x 3.75"(H). Nylon outer ring included.

42-241R.....14.95



HELM CABLE ADAPTOR

You can now fit the newer QC cables to your older SAFE-T or BIG-T helms with threaded spigots •The adaptor simply threads into your helm and quick connect cables then snap in place.

42-297R.....SA-27620P31.75



THREADED TUBE WITH BALL

Splashwell threaded tube with ball.

42-063R.....SA-36316P76.95



PLASTIC TRAVEL TUBE

Screws to threaded spigot of SAFE-T / BIG-T helms to protect cable end from corrosion and debris.

42-262R.....SA-35680P15.50



CABLE BOOT

For use in running steering and throttle cables through splash well walls. Zips tight around cables.

42-237R.....2"13.95

42-239R4 1/2"21.50



OVAL MOTOR WELL BOOT

For use in running steering and throttle cables through splash well walls.

42-068R.....5" x 2"4.95





NEW XTREME SSX176 MECHANICAL STEERING KITS

Smoothest and lowest steering effort mechanical helm offered in the market place yet still offers easy installation.

- Complete steering system including new helm, high efficiency XTREME™ steering cable design and new style bezel.
- Quick connect feature on both steering cable and spent travel tube for easy quick installation.
- Installs in same mounting pattern and bracket location as current SeaStar Solutions® steering systems.
- Smallest footprint possible to accommodate small/tight dash helm stations.
- This kit contains : 1 - SHX7606P, XTREME NFB helm, Bezel kit and mounting hardware.

1 - SSCX64XX, Steering Cable.

42-860P	11'	585.00	42-868P	19'	585.00
42-861P	12'	585.00	42-869P	20'	585.00
42-862P	13'	585.00	42-870P	21'	585.00
42-863P	14'	585.00	42-871P	22'	585.00
42-864P	15'	585.00	42-872P	23'	585.00
42-865P	16'	585.00	42-873P	24'	585.00
42-866P	17'	585.00	42-874P	25'	585.00
42-867P	18'	585.00				

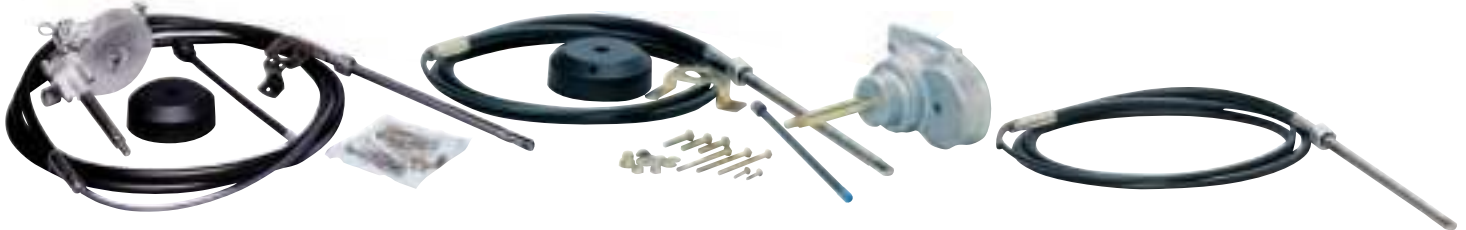

SAFE-T QC STEERING KITS

Safe-T QC® is ideal for power steered boats in which "No feedback™ systems" are not required. Compact rotary helm unit occupies minimum space behind the dashboard, 2 turns lock to lock for standard level, variety of bezels offer mounting flexibility. Stainless steel cable output ends minimize corrosion, standard 3/4" tapered shaft. Exceeds A.B.Y.C. safety standards.

42-122P	10'	355.00
42-123P	11'	355.00
42-124P	12'	355.00
42-125P	13'	355.00
42-126P	14'	355.00
42-127P	15'	355.00
42-128P	16'	355.00
42-129P	17'	355.00
42-130P	18'	355.00
42-131P	19'	355.00
42-132P	20'	355.00
42-133P	21'	415.00
42-179P	22'	425.00
42-180P	23'	435.00

NO FEEDBACK (NFB) 4.2 O/B STEERING KITS

The NFB 4.2 no feedback kit is a heavy duty system with 4.2 turns lock-to-lock, designed for V6 and smaller engines up to 50 MPH with wheel diameters up to 16" . Ultra smooth steering. Helm has standard 3/4" tapered shaft to fit most wheels. Snap in installation with Teleflex's quick connect cable. Kit includes: Helm, Cable and 90° bezel. For boats with speeds in excess of 50 MPH.

42-480P	10'	499.00
42-481P	11'	499.00
42-482P	12'	499.00
42-483P	13'	499.00
42-484P	14'	499.00
42-485P	15'	499.00
42-486P	16'	499.00
42-487P	17'	499.00
42-488P	18'	499.00
42-489P	19'	499.00
42-490P	20'	499.00

QUICK CONNECT & NFB REPLACEMENT CABLES (CABLE MODEL SSC-62)

42-135P	10'	219.00
42-136P	11'	219.00
42-137P	12'	219.00
42-138P	13'	219.00
42-139P	14'	219.00
42-140P	15'	219.00
42-141P	16'	219.00
42-142P	17'	219.00
42-143P	18'	219.00
42-144P	19'	219.00
42-145P	20'	219.00
42-242P	21'	334.00
42-146P	22'	344.00
42-243P	23'	353.00
42-244P	24'	363.00
42-382P	25'	372.00
42-349P	26'	382.00
42-383P	27'	391.00
42-350P	28'	400.00
42-355P	30'	419.00



LINK ARM KIT

Fits Johnson and Evinrude

42-061RSA27361P182.95



SPLASHWELL MOUNT KIT

42-062RSA27253P319.95



CLAMP BLOCK KIT (O/B)

42-059RSA27055P189.95



INBOARD CLAMP KIT

42-245RSA27578P196.95



ALUMINUM SUPPORT TUBE

42-064RSA27274P45.95



TRANSOM SUPPORT MOUNT KIT

42-058RSA27256P309.95



CABLE GUARD

This guard provides protection against salt and sand corrosion to your QC cable steering rod.

42-250RSA-39329P23.50



CLEVIS KIT

42-060RSA27314P82.95

Installation Guidelines for Teleflex Rotary Mechanical Steering Systems

New Installation:

Measure cable routing path from wheel center line to engine connection, as follows :

A = Center line of wheel to gunwale (or deck, if routed downward),

B = Dash to transom,

C = Gunwale to centerline of cable connection at centered tiller.

For Cable installations through the Engine Tilt Tube: Add A, B & C + 6", and round up to the next foot. Order that cable length.

For Cables Mounted to Transom, Splashwell or Stringer: Add A, B & C, then subtract 6" and round up to the next foot. Order that length cable.

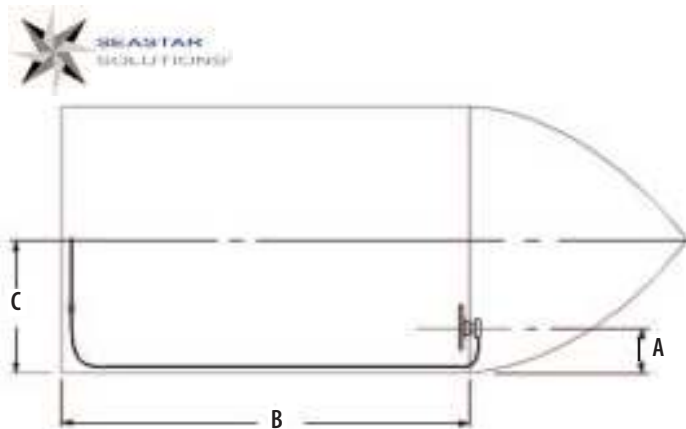

How to Measure SSC62 Steering Cables from Teleflex

Replacement of Existing Cable

If possible, find part number stamped on the plastic jacket of the old cable. If you removed the old cable, measure for the replacement cable as follows:



For Rotary Steering Cable Replacement, Measure Existing Cable as follows: Measure plastic cable jacket ("Y" dimension, shown in above drawing) in inches, add 18" and round up to the next foot. Order that length cable..



SCHMITT VISION FX STAINLESS STEEL WHEEL

316 cast stainless steel. Stainless steel finger grip rim. 3/4" tapered shaft. (Centre Faux nut sold separately)

- 42-104M13 1/2" Dia. - NO KNOB219.00
- 42-105M15 1/2" Dia. - NO KNOB239.00
- 42-106M13 1/2" Dia. - WITH KNOB279.00
- 42-107M15 1/2" Dia. - WITH KNOB309.00

- 42-108MCentre Faux Nut28.95



STEERING WHEEL WITH BALL

Deep dish, 304 stainless steel steering wheel complete with stainless steering ball. 3/4" standard taper shaft will fit all our helms. Comes with plastic hub cover.

- 42-034R13 1/2" Diameter105.00
- 42-035R15 1/2" Diameter115.00



TELEFLEX "ACE" STEERING WHEEL

Rugged, stylish design. 13.5" diameter. Fits standard 3/4" tapered shafts.

- 42-001R13 1/2"62.95



STAINLESS STEEL WHEEL

Stylish heavy-duty construction. Used extensively in locations where netting can be tangled with wheel. 5 spoke, 15 1/2" wheel. 3/4" tapered bore.

- 42-013R15 1/2"109.00



STAINLESS STEEL SPORT WHEEL

With finger grips and control knob.

- 42-042R15 1/2" Dia249.00



TELEFLEX "CHAMPION" STEERING WHEEL

Black textured finish, moulded finger grips, exceeds safety standards. 3/4" tapered bore.

- 42-005R13 1/2"94.95



13.5" STEERING WHEEL

3 spoke, easy to hold and use. Aluminum hub with tapered bore (3/4"). Non-Magnetic, will not affect the compass. Aluminum frame, PU sleeves.

- 42-003R13 1/2"66.95



TELEFLEX "VIPER" STEERING WHEEL

A deluxe black urethane, foam covered wheel. Sturdy aluminum spokes in satin finish. 3/4" tapered bore.

- 42-006R14"219.95



FOAM COVERED WHEEL

Stainless steel hub and spokes. Rim is covered with black foam for non-slip effect. Black plastic hub with 3/4" tapered bore.

- 42-007R15 1/2"149.95



STAINLESS STEEL STEERING KNOBS

3/4" to 1" Clamp

- 42-014RStandard21.95
- 42-043RDeluxe26.95



ENOMY PLASTIC STEERING WHEEL

3/4" tapered bore. Great wheel at a great price.

- 42-002R13 1/2"29.95



Kobel products have a global reputation for durability and performance, and are constantly being improved upon. Most of our products are patented, evidence of the Kobelt commitment to better design and efficiency. We are unique in the marketplace as we are the only manufacturer providing a non-corrosive product for the marine environment. Using the best materials for construction and skillful engineering have enabled us to offer our customer the best warranty in the industry.



KOBELT ENGINE CONTROLS

Twin lever MEDIUM DUTY controls

This medium duty control is one of the most used in Atlantic Canada.

Requires connection kit.

Model 2009 for either single or twin stations. 3" cable stroke.

42-287K.....Model 2009..... 818.00



KOBELT ENGINE CONTROLS

Twin lever HEAVY DUTY controls

This heavy duty control is designed to move the stiffest of throttles and clutches. Constructed of all bronze and stainless steel. Trouble free!

Model 2011 Suitable for single or twin stations. 3" cable stroke.

Requires connection kit.

42-288K.....Model 2011..... 1060.00



KOBELT CABLE CONNECTION KITS

1 kit required for each cable.

For 33C / 3300 series cables

42-290K2009 (2009-0901).....46.75

42-289K2015 (2015-0901).....46.75

42-291K2011 (2011-0901).....46.75

For 43C / 4300 series Cables

42-293K2009 (2009-0902).....52.00

42-292K2015 (2015-0902).....52.00

42-294K2011 (2011-0902).....52.00

KOBELT ENGINE CONTROLS

Twin lever MEDIUM DUTY controls

This control incorporates all standard features of Kobelt's push/pull control. Medium duty control using all bronze and stainless steel construction. Requires connection kit.

Model 2015 single or twin stations. 3" cable stroke.

42-286K.....Model 2015..... 830.00



www.mercersmarine.com

- Always Open
- Sale & Feature Items
- View Catalogue
- Thousands of products
- Updated Regularly

- Up to date Pricing
- Mobile Friendly
- Shop from anywhere at anytime

find us on



S AND TWIN S CONTROLS

Single function, single or twin lever. "S" series controls have a highly polished, corrosion resistant brass plated cover, with stainless steel hanger plates. Friction control levers. Accepts 33C / 3300 and 43C / 4300 series cables.

Single lever for clutch or throttle
 42-491M.....CH-5210P 335.00

Twin levers for clutch and throttle
 42-492M.....CH-5200P 419.00

Parts and Accessories

Clutch detent kit

Gives detent feel in forward, neutral & reverse.

42-493M.....22328 35.95

Throttle hold kit

42-494M.....306997 93.95

Replacement control knobs

42-495M.....Red..... 12.50
 42-496M.....Black..... 12.50



MT-3 CONTROLS

Dual function, single lever for single engine applications. Dual function, dual lever for twin engine applications. This rugged, top mount control allows one hand to control all engine functions. Start and warm ups are done by pulling out the control lever in the neutral position. This disengages the clutch and allows the throttle to advance forward in the neutral position, thus allowing an increase in RPMs. Returning to the neutral position re-engages the clutch. Built in friction drag to prevent throttle slippage and creep, neutral safety switch to prevent starting in gear. Uses TeleflexMorse 33C / 3300 series cables.

Single lever / Clutch and throttle for single engine
 42-499M.....CH-5310P 610.00

Twin levers / Clutch and throttle for twin engines
 42-500M.....CH-5300P 1075.00

Replacement control knobs

42-495M.....Red..... 12.50
 42-496M.....Black..... 12.50



ECONOMY CONTROL

Exceptional value! Solid brass, chrome-plated. Dual station capabilities. Use either 33C / 3300 or 43C / 4300 series cables.

Not a Teleflex or Kobelt product

42-065R.....299.00



SINGLE LEVER TOP MOUNT CONTROLS

The 7500 series controls offer options that most top mount controls in the market do not. The standard items on these controls are the shapely and balanced hand grip that gives you a very smooth yet solid feel. The neutral safety switch, and the neutral warm up button. These controls can not only use the 3300/33C style controls cables, but will accept most OEM control cables without adaptation.

No Trim

42-788M CH7540P418.95

With Trim

42-790M CHX8141P649.00

Omega Series Gauges

FEATURES

- Instruments available for most outboards, stern drives and gasoline-powered inboards.
- Scratch-resistant domed glass lenses
- Enhanced illumination: through-dial and perimeter lighting for excellent readability at night.
- Low-range speedometers
- U.S. and metric scales, with ISO symbols, where appropriate



TEMPERATURE GAUGE

42-832R.....57904P54.95



FUEL GAUGE

42-840R.....57902P57.95



OIL PRESSURE GAUGE

0-80 psi
42-834R.....57903P54.95



ENGINE HOUR METER

42-844R84760P99.95



AMMETER

42-836R.....Ammeter (68356P)53.95



VOLTMETER

42-838RVoltmeter (57901P)57.95

HEAVY DUTY VOLTMETER

42-219R.....20V to 32V, Voltmeter90.95



TRIM GAUGE

Trim, Mariner/Merc,Cobra,Volvo DP/SX, Yamaha 2001+

42-842R57905P57.95



HEAVY DUTY DIESEL TACHOMETER

Diesel Tachometer - (0-3500 RPMs)
42-208R82302P171.95



TEMPERATURE SENDERS

42-220R.....1/8" Single Station35.95
42-221R.....1/4" Single Station23.95
42-222R.....3/8" Single Station25.95
42-223R.....1/2" Single Station25.95
42-224R.....3/8" Dual Station39.95
42-225R.....1/2" Dual Station28.95

OIL PRESSURE SENDERS

For Single Station

42-226RIA-1500146.95

For Dual Station

42-227RIA-1500353.95



Model 33C / 3300 Xtreme



Model 43C / 4300 Xtreme



TELEFLEX ENGINE CONTROL CABLES

33C / 3300 Xtreme Cables

10-32 threads, 3" travel, 4" minimum bend radius.

42-550P.....6'	71.74
42-551P.....7'	73.30
42-552P.....8'	77.45
42-553P.....9'	77.01
42-554P.....10'	78.78
42-555P.....11'	80.60
42-556P.....12'	82.50
42-557P.....13'	84.30
42-558P.....14'	86.05
42-559P.....15'	87.93
42-560P.....16'	89.75
42-561P.....17'	91.54
42-562P.....18'	93.43
42-563P.....19'	95.20
42-564P.....20'	97.05
42-565P.....21'	98.90

42-566P.....22'	100.70
42-567P.....23'	102.53
42-568P.....24'	104.36
42-569P.....25'	107.80
42-570P.....26'	110.76
42-571P.....28'	116.70
42-572P.....30'	122.60
42-573P.....32'	149.65
42-574P.....34'	165.62
42-575P.....36'	181.68
42-576P.....38'	197.65
42-577P.....40'	213.68
42-578P.....42'	229.66
42-579P.....44'	245.60

43C / 4300 Xtreme Cables

1/4" threads, 3" travel, 5" minimum bend radius.

(Replaces 43C cables)

42-163M.....10'	133.50
42-164M.....12'	138.85
42-165M.....14'	144.50
42-166M.....16'	149.90
42-167M.....18'	155.25
42-168M.....20'	160.50
42-169M.....22'	165.85
42-170M.....24'	171.35
42-171M.....26'	176.70
42-172M.....28'	182.25
42-173M.....30'	187.65
42-174M.....32'	193.00
42-175M.....34'	198.45
42-176M.....36'	203.75
42-177M.....38'	209.25
42-178M.....40'	215.00

CABLE CONNECTION FITTINGS



UNIVERSAL CONNECTION KIT

Contains 2 ball joints and 2 brackets for throttle and clutch cables.

Complete Kit - 33C & 3300 Cables

42-088R.....99.95

Bracket Only - 33C & 3300 Cables

42-090R.....20.50

Ball Joint Only - 33C & 3300 Cables

42-089R.....25.95

Ball Joint Only - 43C & 4300 Cables

42-282R.....43.95



CLAMPS & SHIM KITS

42-093R.....33C & 3300 cables.....16.50 pk.

42-283R.....43C & 4300 cables.....53.95 pk.



CLEVIS

For connecting second engine control in series with primary engine control. For use with dual lever controls.

42-092R.....33C & 3300 cables.....34.75 ea.

42-284R.....43C & 4300 cables.....32.95 ea.

CONNECTION PIVOT

42-094R.....33C & 3300 cables.....17.50 ea.

42-285R.....43C & 4300 cables.....22.95 ea.



DC CONTROL

This control can be used for throttle, choke, air or fuel shutdown as well as a governor or valve control. Can be flush or side mounted. Mounting with stainless steel angle bracket is optional. Use 33C or 3300 cables. Cables not included.

42-600M.....Model 301916.....138.95

Optional Stainless Steel mounting bracket

42-601M.....Model 48210.....100.75



PARALLEL CONNECTION KIT CA-27328

For parallel connections for clutch or throttle cables in dual station hook ups •One kit required for each cable.

42-091R.....33C & 3300 cables.....149.95

42-328R.....Dual Bracket only.....64.95



TERMINAL EYE

42-462R.....33C & 3300 cables.....16.50

42-459R.....43C & 4300 cables.....30.95

TERMINAL EYE PIN KIT

42-460R.....3300/4300 cables.....22.95



CC205 (479) CONTROL CABLES

For most OMC / Johnson / Evinrude engines from 1979 to present using OMC controls. Before ordering, please check cables carefully as exceptions may apply.

42-702P	10'	67.06
42-703P	11'	68.32
42-704P	12'	69.45
42-705P	13'	70.60
42-706P	14'	71.75
42-707P	15'	72.90
42-708P	16'	74.10
42-709P	17'	75.20
42-710P	18'	76.50
42-711P	19'	77.61
42-712P	20'	78.80
42-713P	21'	107.23
42-714P	22'	109.20
42-715P	23'	116.35
42-716P	24'	117.25

CC179 (600A) CONTROL CABLES

Fits most Mercury/Mariner/Mercruiser engines except pre-1993 models up to 40HP. Before ordering, please check cables carefully as exceptions may apply.

42-722P	10'	65.32
42-723P	11'	67.15
42-724P	12'	69.30
42-725P	13'	71.25
42-726P	14'	73.12
42-727P	15'	75.03
42-728P	16'	76.62
42-729P	17'	78.42
42-730P	18'	79.84
42-731P	19'	81.70
42-732P	20'	83.15
42-733P	21'	99.45
42-734P	22'	101.50
42-735P	23'	104.10
42-736P	24'	106.25

CC210 (630) CONTROL CABLES

Fits pre-1993 Mariner engines up to 40HP. Before ordering, please check cables carefully as exceptions may apply.

42-742P	10'	87.83
42-743P	11'	89.61
42-744P	12'	91.30
42-745P	13'	93.40
42-746P	14'	95.10
42-747P	15'	97.17
42-748P	16'	98.89
42-749P	17'	100.60
42-750P	18'	102.70
42-751P	19'	104.41
42-752P	20'	106.60
42-753P	21'	109.59
42-754P	22'	112.09
42-755P	23'	122.82
42-756P	24'	125.65

How to Measure Control Cables "Measure Twice. Order Once"

Outboards:

Measure from control along unobstructed cable routing to the center of outboard. Add 4 feet to allow for loop which provides unrestricted engine movement. Round up to the next foot and order required cable part number.



Typical Outboard Cable Routing:

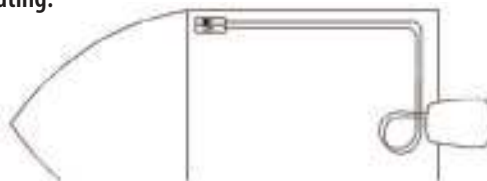

Inboards & Stern Drives:

Measure from control along unobstructed cable routing to shift and/or throttle connection. Round this dimension up to the next foot and order required cable part number.

Typical Stern Drive (I/O) or Inboard Cable Routing:

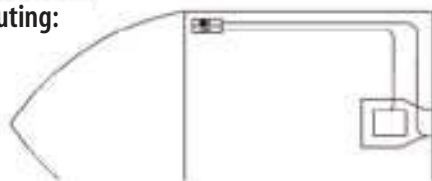

CCX189 MERCURY GEN 2 CONTROL CABLES

Premium Mercury generation 2 cables. Designed to fit Mariner, Mercury, Mercruiser any other engines using the Mercury 2003 to present 4000 series controls.

42-675P	8'	74.83
42-676P	9'	76.74
42-677P	10'	78.60
42-678P	11'	80.56
42-679P	12'	82.45
42-680P	13'	84.35
42-681P	14'	86.28
42-682P	15'	88.16
42-683P	16'	90.05
42-684P	17'	91.99
42-685P	18'	93.87
42-686P	19'	95.78
42-687P	20'	97.72
42-688P	21'	99.58
42-689P	22'	101.50
42-690P	23'	103.40
42-691P	24'	105.30
42-692P	25'	107.23
42-693P	26'	109.80



ENGINE INSTRUMENT PANELS

These superior quality engine instrument panels are made from attractive and sturdy ABS plates. They are all corrosion resistant and are fitted with the best marine instruments and come with a heavy-duty plug for connection to wiring harness. (Not a Teleflex Product.)

DIESEL ENGINE PANEL

Complete with tachometer, oil pressure, temperature, volt and engine hour gauges. Glow plug, ignition switch and panel light. 12V negative ground.

42-234M.....799.00

WIRING HARNESS

20 ft. heavy-duty harness. Fits both panels. 8 pin connection. One end to plug into panel.

42-236M.....269.00



PROPELLER BUSHINGS

Allows use of a propeller with oversize bore. Nylon construction. C/W brass key.

Allows 1 1/4" prop. to fit 1" Shaft

44-135R.....97.00

Allows 1 1/2" prop. to fit 1 1/4" Shaft

44-136R.....121.00

Allows 1 3/4" prop. to fit 1 1/2" Shaft

44-137R.....178.00

Allows 2" prop. to fit 1 1/2" Shaft

44-138R.....192.00

Allows 2" prop. to fit 1 3/4" Shaft

44-139R.....192.00

Allows 2 1/4" prop to fit 2" Shaft

44-140R.....279.00

Allows 2 1/2" prop to fit 2" Shaft

44-590R.....289.00

Allows 2 1/2" prop to fit 2 1/4" Shaft

44-591R.....299.00



S. S. COTTER PINS

44-191T.....3/32" x 1 1/2"0.50 ea

44-054T.....1/8" x 1 3/4"0.75 ea

44-055T.....5/32" x 2"0.65 ea

44-056T.....3/16" x 2 1/2"1.85 ea

44-057T.....1/4" x 3"1.70 ea

44-305T.....1/4" x 4"1.90 ea



STANDARD STEADY BEARING

2 Bolt Base, 2 Bolt Cap

44-684K.....1"159.00

44-685K.....1 1/4"179.00

44-686K.....1 1/2"219.00

44-687K.....1 3/4"289.00

44-688K.....2"359.00



STANDARD STEADY BEARING

4 Bolt Base, 2 Bolt Cap

44-689K.....2"389.00

44-690K.....2 1/4"475.00

44-691K.....2 1/2"595.00

44-692K.....2 3/4"650.00

44-693K.....3"825.00



4 Bolt Base, 4 Bolt Cap

44-694K.....3 1/2"1175.00

44-695K.....4"1525.00

44-696K.....4 1/2"2395.00

44-697K.....5"3325.00

44-698K.....5 1/2"4375.00



LOVEJOY COUPLINGS

Join two shafts of equal or different size by using two couplings plus Lovejoy coupling insert. **Type L0-95**

44-511P1/2" Shaft18.95

44-512P5/8" Shaft18.95

44-513P3/4" Shaft18.95

44-514P7/8" Shaft18.95

44-515P1" Shaft18.95

LoveJoy Coupling Insert

44-510P(Fits all above)5.95



RUDDER STUFFING BOX

Bronze, complete.

44-009M.....1 1/4"525.00

44-010M.....1 1/2"750.00

44-011M.....1 3/4"1075.00

44-012M.....2"1095.00

44-675M.....2 1/4"1950.00



RUDDER BEARING FLANGE

44-676PFor 1 1/4" Shaft96.00

44-677PFor 1 1/2" Shaft103.00

44-678PFor 1 3/4" Shaft179.00

44-679PFor 2" Shaft179.00

44-680PFor 2 1/4" Shaft248.00



BRONZE PROPELLER NUTS

Heavy Nut & Jam Nut Style.

44-1511K.....For 1 1/4" Shaft.....27.95

44-1512K.....For 1 1/2" Shaft.....60.95

44-1513K.....For 1 3/4" Shaft.....73.95

44-1514K.....For 2" Shaft.....119.95

44-1515K.....For 2 1/4" & 2 1/2" Shaft208.00



MACHINE BRONZE PROPELLER NUTS

44-015K.....For 1 1/2" Shaft185.00

44-016K.....For 1 3/4" Shaft339.00

44-017K.....For 2" Shaft.....349.00

44-018K.....For 2 1/4" & 2 1/2" Shaft519.00



PILLOW BLOCK BEARINGS

44-038R.....	5/8"	22.95
44-039R.....	3/4"	23.50
44-040R.....	1"	23.95
44-304R.....	1 1/8"	31.95
44-041R.....	1 1/4"	34.95
44-042R.....	1 1/2"	44.50
44-043R.....	1 3/4"	48.95
44-601R.....	1 15/16"	56.95
44-044R.....	2"	60.50



FLANGE BEARINGS

44-620R.....	5/8"	22.95
44-621R.....	3/4"	23.50
44-622R.....	1"	23.95
44-623R.....	1 1/4"	34.95
44-624R.....	1 1/2"	44.50
44-625R.....	1 3/4"	48.95
44-626R.....	1 15/16"	56.95
44-627R.....	2"	60.50



STEEL SPLIT COUPLINGS

"High-Strength" solid steel machined couplings. Supplied as female, but converts to male with connection spigot below. All 5" couplings have 4 bolt holes. All other couplings have 6 holes.

Borg Warner

44-805K.....	5" Dia x 1 1/2" shaft	825.00
44-806K.....	5" Dia x 1 3/4" shaft	825.00
44-807K.....	5" Dia x 2" shaft	825.00
44-808K.....	5 3/4" Dia x 1 3/4" shaft	835.00
44-809K.....	5 3/4" Dia x 2" shaft	835.00
44-810K.....	5 3/4" Dia x 2 1/4" shaft	835.00

CONNECTION SPIGOTS

Converts all female coupling above to male. Note: To connect two shafts, you require 2 female couplings plus one spigot.

44-818K.....	5" Coupling Spigot	57.95
44-819K.....	5 3/4" Coupling Spigot	84.95
44-820K.....	7 1/4" Coupling Spigot	84.95



SPLIT COUPLINGS - DUCTILE IRON

MALE 5" Dia. Couplings. 4 Hole
(Fits Velvet Drive)

44-026M.....	5" Dia. x 1 1/4" shaft	225.00
44-027M.....	5" Dia. x 1 1/2" shaft	225.00
44-028M.....	5" Dia. x 1 3/4" shaft	250.00
44-029M.....	5" Dia. x 2" shaft	250.00

5" Dia. Flange available in "Male Half Only"

FEMALE 5 3/4" couplings. 6 hole

Comes as "Female" but can convert to male with "Insert Ring" below.

44-1613M.....	5 3/4" Dia. x 1 1/2" shaft	499.00
44-1614M.....	5 3/4" Dia. x 1 3/4" shaft	499.00
44-1615M.....	5 3/4" Dia. x 2" shaft	499.00



STUFFING BOX PACKING

Price Per Foot

44-058R.....	1/4"	1.85
44-059R.....	5/16"	2.59
44-060R.....	3/8"	3.75
44-061R.....	1/2"	6.50
44-062R.....	5/8"	9.95
44-387R.....	3/4"	16.50

Price Per 10 LB. Reel

44-370R.....	1/4" (346 ft)	P.O.R.
44-371R.....	5/16" (219 ft)	P.O.R.
44-372R.....	3/8" (157 ft)	P.O.R.
44-373R.....	1/2" (85 ft)	P.O.R.
44-374R.....	5/8" (54 ft)	P.O.R.
44-375R.....	3/4" (39 ft)	P.O.R.





KEEL COOLER PIPE & FITTINGS

Type "K" Hard Copper Pipe and Fitting. The only type that should be used for keel coolers.



NAVAL BRASS, RUBBER SLEEVE BEARINGS

Ord. No.	Codes	Size A	OD"B"	Length	Price
44-459M	ACID	7/8"	1 1/4"	3 1/2"	117.95
44-089M	BACK	1"	1 1/4"	4"	114.95
44-090M	BAIT	1"	1 3/8"	4"	120.95
44-091M	BALE	1"	1 1/2"	4"	118.95
44-1030M	BEAM	1 1/8"	1 1/2"	4 1/2"	149.95
44-092M	BIRD	1 1/4"	1 3/4"	5"	152.95
44-093M	BITE	1 1/4"	2"	5"	159.95
44-094M	BLOW	1 1/4"	2 1/8"	5"	175.95
44-095M	BOSS	1 1/2"	2"	6"	210.95
44-096M	BRAD	1 1/2"	2 3/8"	6"	223.90
44-097M	BROW	1 3/4"	2 3/8"	7"	259.95
44-098M	BUCK	1 3/4"	2 5/8"	7"	266.95
44-099M	CALL	2"	2 5/8"	8"	296.50
44-100M	CALM	2"	3"	8"	303.75
44-101M	CARE	2 1/4"	2 15/16"	9"	369.95
44-667M	CARD	2 1/4"	3"	9"	327.90
44-102M	CART	2 1/4"	3 1/8"	9"	385.50
44-103M	CASE	2 1/4"	3 3/8"	9"	425.00
44-104M	CORD	2 1/2"	3 1/8"	10"	454.70
44-105M	CORN	2 1/2"	3 3/8"	10"	457.95
44-668M	COVE	2 1/2"	3 1/2"	10"	486.95
44-106M	CROW	2 3/4"	3 3/8"	11"	529.95
44-107M	CURD	2 3/4"	3 3/4"	11"	557.00
44-669M	DANE	3"	3 3/4"	12"	596.00
44-108M	DARE	3"	4"	12"	615.00
44-109M	DARN	3 1/4"	4"	13"	709.00
44-110M	DINE	3 1/2"	4 1/4"	14"	796.00
44-111M	DOCK	3 1/2"	4 1/2"	14"	803.00
44-1069M	DONE	3 3/4"	4 1/2"	15"	918.00
44-112M	EARN	4"	5"	16"	1230.00
44-665M	EASE	4"	5 1/4"	16"	1325.00
44-607M	EDIT	4 1/4"	5 1/2"	17"	1478.00
44-113M	EPIC	4 1/2"	5 1/2"	18"	1575.00
44-666M	EDGE	4 1/2"	5 3/4"	18"	1680.00
44-460M	FACE	5"	6 1/8"	20"	2255.00
44-461M	FIND	5 1/2"	7"	22"	3150.00

BRONZE STUFFING BOX

Heavy-Duty, 4 Hole.

Left Hand

44-001K.....	1 1/2"	P.O.R.
44-002K.....	1 3/4"	P.O.R.
44-003K.....	2"	P.O.R.

Right Hand

44-005K.....	1 1/2"	P.O.R.
44-006K.....	1 3/4"	P.O.R.
44-007K.....	2"	P.O.R.



Copper Pipe

38-091K.....	1" x 12'	199.00
38-092K.....	1 1/4" x 12'	249.00
38-093K.....	1 1/2" x 12'	309.00



Bronze Solder Inlet Fitting

38-105J.....	1"	155.40
38-106J.....	1 1/4"	215.25
38-162J.....	1 1/2"	259.95



Return Bends

38-096K.....	1"	60.00
38-097K.....	1 1/4"	159.00
38-183K.....	1 1/2"	199.00



90° Elbows

38-099K.....	1"	7.50
38-100K.....	1 1/4"	12.00
38-184K.....	1 1/2"	19.00



Couplings

38-102K.....	1"	5.35
38-103K.....	1 1/4"	6.30
38-185K.....	1 1/2"	9.95



DRIVESAVERS

- A flexible, non-metallic impervious barrier between transmission and shaft that reduces drive train vibration and noise, blocks electrical currents from the water and helps control damage and misalignment from torsional engine movement.
- The DriveSaver absorbs the extreme shock and torque of collision and breaks apart, leaving transmission and engine intact.
- Works under normal conditions for the life of the drive train, with no lubrication or maintenance
- Installs quickly without cutting or machining shaft ; seperate drive flanges, insert coupling, align and bolt.

PLUS RATED DRIVESAVERS - PR MODELS

- For more powerful commercial diesel engine applications
- Model may vary according to gear reduction ratio.

Transmission Model	Flange Dia.	Bolts	Bolt Dia.	Bolt Circle	Pilot Dia.	Torque ft.-lb.	Model	Item #	Price
DRIVESAVERS									
Yanmar	100 mm	4	10 mm	78 mm	50 mm	550	424Y	44-1588M	\$731.00
Yanmar	120 mm	4	10 mm	100 mm	65 mm	675	524Y	44-1589M	\$941.00
Velvet Drive 71C with 5" Dia. Coupling	5"	4	7/16"	4 1/4"	2 1/2"	675	504	44-1590M	\$785.00
Velvet Drive 72C	5"	4	7/16"	4 1/4"	2 1/2"	675	504	44-1590M	\$785.00
Hurth HBW 400	5"	4	7/16"	4 1/4"	2 1/2"	675	504	44-1590M	\$785.00
Newage PRM 210	5"	4	7/16"	4 1/4"	2 1/2"	675	504	44-1590M	\$785.00
Velvet Drive 73C	5 3/4"	6	1/2"	4 3/4"	3"	1800	5756	44-1592M	\$1075.00
Newage PRM 310	5 3/4"	6	1/2"	4 3/4"	3"	1800	5756	44-1592M	\$1075.00
Newage PRM 610	5 3/4"	6	1/2"	4 3/4"	3"	1800	5756	44-1592M	\$1075.00
Twin Disc MG506 (Requires Bushing Kit**)	5 3/4"	6	1/2"	4 3/4"	3"	1800	5756	44-1592M	\$1075.00
Twin Disc MG507 (Requires Bushing Kit**)	5 3/4"	6	1/2"	4 3/4"	3"	1800	5756	44-1592M	\$1075.00
**Bushing Kit for Model 5756 - used to reduce required bolt size from 5/8" to 1/2" Diameter.								44-1598M	\$267.00
Capitol 4HE-10700	7 1/4"	6	5/8"	6"	3 3/4"	3200	7256	44-1595M	\$1118.00
Capitol HY-22000	7 1/4"	6	5/8"	6"	3 3/4"	3200	7256	44-1595M	\$1118.00
Capitol HY-400	7 1/4"	6	5/8"	6"	3 3/4"	3200	7256	44-1595M	\$1118.00
Alison M	7 1/4"	6	5/8"	6"	3 3/4"	3200	7256	44-1595M	\$1118.00
Newage PRM 60	7 1/4"	6	5/8"	6"	3 3/4"	3200	7256	44-1595M	\$1118.00
Twin Disc MG506(Requires Bushing Kit*)	7 1/4"	6	5/8"	6"	3 3/4"	3200	7256	44-1595M	\$1118.00
Twin Disc MG507(Requires Bushing Kit*)	7 1/4"	6	5/8"	6"	3 3/4"	3200	7256	44-1595M	\$1118.00
Twin Disc MG509(Requires Bushing Kit*)	7 1/4"	6	5/8"	6"	3 3/4"	3200	7256	44-1595M	\$1118.00
*Bushing Kit for Model 7256 - used to reduce required bolt size from 3/4" to 5/8" Diameter.								44-1599M	\$276.00
PLUS RATED DRIVESAVERS									
For Diesels over 120 hp	5"	4	7/16"	4 1/4"	2 1/2"	1600	504 PR	44-1591M	\$910.00
For Diesels over 250 hp	5 3/4"	6	1/2"	4 3/4"	3"	1800	5756A PR	44-1593M	\$1135.00
For Diesels over 250 hp	5 3/4"	6	1/2"	4 3/4"	3"	1800	5756 PR	44-1594M	\$1154.00
For Diesels over 350 hp	7 1/4"	6	5/8"	6"	3 3/4"	4400	7256 PR	44-1596M	\$1185.00

$$\text{ft.-lb.} = \frac{\text{Engine Horsepower}}{\text{Engine rpm}} \times 5250 \times \text{Reduction Rate}$$



DO-NUT SHAFT ZINC ANODES

38-614R	3/4" Shaft	14.30
38-615R	7/8" Shaft	12.35
38-616R	1" Shaft	16.60
38-617R	1 1/8" Shaft	16.85
38-000R	1 1/4" Shaft	15.95
38-618R	1 3/8" Shaft	24.95
38-001R	1 1/2" Shaft	20.40
38-002R	1 3/4" Shaft	33.75
38-003R	2" Shaft	31.25
38-004R	2 1/4" Shaft	39.50
38-005R	2 1/2" Shaft	49.95
38-006R	2 3/4" Shaft	48.95
38-007R	3" Shaft	48.95
38-249R	3 1/2" Shaft	78.95
38-250R	4" Shaft	74.95



COMMERCIAL ANODES

Suitable for bolting or welding. Popular teardrop style.
Size: 3" x 9" x 1 1/4".
Zinc Model - Steel Straps
38-014R5 lbs.....42.95
Aluminum Model - Steel Straps
38-648R2.25 lbs24.95



TEARDROP ANODES

38-253R.....1 3/4" x 3 1/2"5.85
38-018R.....2" x 5 1/4"12.75



HULL ANODES

Comes with 2 tabs for welding or bolting. Size: 3" x 12" x 1 1/4".
Zinc Model - Steel Straps
38-015R10.5 lbs84.95
Aluminum Model - Steel Straps
38-649R5.25 lbs52.95



I/O AND O/B ANODES

For Mercury and Mercruiser.
38-262RSmall tab (31640)19.95
38-263RLarge tab (34127)22.95
Mercruiser Nut
38-261R7/16" NPT core (55989).....7.50



STREAMLINED SHAFT ANODES

38-619R	3/4" Shaft	18.75
38-251R	7/8" Shaft	16.50
38-008R	1" Shaft	16.50
38-009R	1 1/8" Shaft	16.50
38-010R	1 1/4" Shaft	19.95
38-620R	1 3/8" Shaft	21.50
38-011R	1 1/2" Shaft	20.95
38-012R	1 3/4" Shaft	29.50
38-013R	2" Shaft	29.50



Large anodes with 4 tabs for welding or bolting.
Size: 6 1/2" x 14" x 1 1/4".

Zinc with Steel Tabs
38-019R24 lbs174.95
Aluminum Model - Steel Straps
38-650R11.75 lbs104.95



DIVERS DREAM HULL ANODE

Size: 12" x 6" x 1/2".
38-654R7.5 lbs92.95

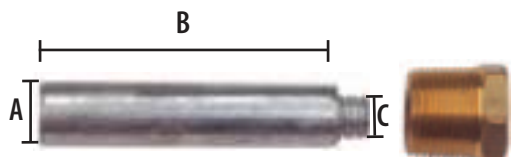

Brass Plugs

ENGINE ANODES

Zinc "Pencil" type anodes for engine blocks & heat exchangers.

Pencil Zincs (Plug Not Included)

Ord. No.	MFG#	Width A	Length B	UNC C	Price
38-656R	(E0Z)	3/8"	1 3/4"	5/16"	1.39
38-657R	(E1Z)	1/2"	2"	3/8"	2.19
38-658R	(E2Z)	5/8"	2"	7/16"	2.95
38-659R	(E3Z)	3/4"	2"	1/2"	3.95
38-660R	(E4Z)	3/4"	3 3/8"	1/2"	5.50
38-661R	(E5Z)	3/4"	3 5/8"	1/2"	5.95

Brass Plugs (Zinc Not Included)

38-664R	1/4" MPT x 5/16" UNC	2.89
38-665R	3/8" MPT x 3/8" UNC	4.95
38-666R	1/2" MPT x 7/16" UNC	8.75
38-667R	3/4" MPT x 1/2" UNC	14.25



ROUND RUDDER ZINC ANODES

38-252R	2 13/16" dia	14.50
38-016R	3 3/4" dia	22.95
38-017R	5" dia	42.50
38-621R	6 7/16" dia	108.95

PACER PUMPS

Pacer Pumps

All Pacer pumps share these same quality features: Self-priming with a maximum suction lift of 25ft. Self flushing volute. Built in check valve to prevent back flow. Self lubricating shaft seal. Stainless steel internal fastenings. Light weight and portable. Complete wet end (body,volute, impeller, bracket) made from corrosion resistant glass and reinforced polyester. Buna-N O-ring Seals.



2" HYDRAULIC MOTOR DRIVEN PUMP

32-480K.....Model SE2JB, HYC.....1018.00
240 gpm @ 3450 rpm.

Replacement Parts

32-546K.....Seal Kit.....155.00
32-533K.....Repair Kit.....82.50
32-543K.....Impeller.....40.50
32-544K.....Volute.....82.50
32-536K.....Check Valve.....37.50
32-537K.....Bracket.....102.00
32-538K.....Body.....134.00
32-539K.....Hardware Kit.....38.95
32-540K.....Fill Plug.....7.95
32-541K.....Drain Plug.....6.50
32-547K.....Hydraulic Motor.....530.00

3" HYDRAULIC MOTOR DRIVEN PUMP

32-495K.....Model SE3LB, HYC.....1118.00
280 gpm @ 3450 rpm

Replacement Parts

32-546K.....Seal Kit.....155.00
32-533K.....Repair Kit.....82.50
32-543K.....Impeller.....40.50
32-544K.....Volute.....82.50
32-536K.....Check Valve.....37.50
32-537K.....Bracket.....102.00
32-545K.....Body.....240.00
32-539K.....Hardware Kit.....38.95
32-540K.....Fill Plug.....7.95
32-541K.....Drain Plug.....6.50
32-547K.....Hydraulic Motor.....530.00



2" ELECTRIC MOTOR DRIVEN PUMP

32-510K.....Model SE2CB, G1.0.....1265.00
100 gpm, 1 hp electric motor.

32-512K.....Model SE2HB, C3.0.....2570.00
180 gpm, 3 hp electric motor.

Replacement Parts

32-533K.....Repair Kit.....82.50
32-534K.....Impeller.....40.50
32-535K.....Volute.....82.50
32-536K.....Check Valve.....37.50
32-537K.....Bracket.....102.00
32-538K.....Body.....134.00
32-539K.....Hardware Kit.....38.95
32-540K.....Fill Plug.....7.95
32-541K.....Drain Plug.....6.50

3" ELECTRIC MOTOR DRIVEN PUMP

32-542K.....Model SE3LB, C5.0C.....2950.00
270 gpm, 5 hp electric motor.

Replacement Parts

32-533K.....Repair Kit.....82.50
32-543K.....Impeller.....40.50
32-544K.....Volute.....82.50
32-536K.....Check Valve.....37.50
32-537K.....Bracket.....102.00
32-545K.....Body.....240.00
32-539K.....Hardware Kit.....38.95
32-540K.....Fill Plug.....7.95
32-541K.....Drain Plug.....6.50



2" PEDESTAL MOUNTED PUMP

32-450K.....Model SE2HB, CSS.....765.00
180 gpm. Requires 3 hp.

Replacement Parts

32-533K.....Repair Kit.....82.50
32-548K.....Impeller.....40.50
32-549K.....Volute.....82.50
32-536K.....Check Valve.....37.50
32-537K.....Bracket.....102.00
32-538K.....Body.....134.00
32-539K.....Hardware Kit.....38.95
32-540K.....Fill Plug.....7.95
32-541K.....Drain Plug.....6.50

3" PEDESTAL MOUNTED PUMP

32-465K.....Model SE3LB, CSS.....858.00
280 gpm. Requires 5hp.

Replacement Parts

32-533K.....Repair Kit.....82.50
32-543K.....Impeller.....40.50
32-544K.....Volute.....82.50
32-536K.....Check Valve.....37.50
32-537K.....Bracket.....102.00
32-545K.....Body.....240.00
32-539K.....Hardware Kit.....38.95
32-540K.....Fill Plug.....7.95
32-541K.....Drain Plug.....6.50



PERKO**PERKO WATER INTAKE STRAINERS**

PERKO Water Strainers are designed for easy installation and cleaning. Features include mounting lugs cast into both sides to assure universal mounting, four outside tie rods and a 304 stainless steel strainer basket to minimize electrolysis. Screen hole size diameter .007 inches, 46% open area. Hinged lugs for the cast bronze cover permit easy removal and cleaning of the strainer basket. A drain plug in the bottom casting is provided for easily removing sediment and draining for winterizing.

MODEL 493 STRAINER

38-708M3/4"402.70
38-490M1"563.15
38-491M1 1/4"568.90
38-492M1 1/2"896.70
38-493M2"1112.45
38-709M2 1/2"1153.00

REPLACEMENT TRANSPARENT CYLINDERS

38-712M3/4"102.25
38-498M1"130.65
38-499M1 1/4"130.65
38-500M1 1/2"185.05
38-501M2"230.40
38-713M2 1/2"230.40

REPLACEMENT "CORK" GASKET KIT**(OLDER MODEL PERKO STRAINERS)**

38-714M3/4"27.05
38-502M1" & 1 1/4"32.55
38-504M1 1/2", 2" & 2 1/2"46.70

REPLACEMENT "RUBBER" GASKET KIT**(NEW MODEL PERKO STRAINERS)**

38-761M3/4"27.05
38-762M1" & 1 1/4"33.25
38-763M1 1/2", 2" & 2 1/2"47.35

REPLACEMENT BASKET STRAINERS

38-710M3/4"96.95
38-494M1"122.80
38-495M1 1/4"138.60
38-496M1 1/2"184.55
38-497M2"239.85
38-711M2 1/2"265.70

REPLACEMENT BOLT KIT

38-716M53.95
---------	-------	------------

**BRONZE SCOOPED STRAINER**

38-119R5" x 3 1/4"55.25
38-120R6 1/4" x 4 1/4"78.60
38-121R8 1/2" x 5 1/2"102.75

**ROUND BRONZE STRAINER**

38-115R3 1/2" dia.30.70
38-116R5" dia.64.95
38-117R6" dia.89.95
38-118R8" dia.142.10

**GROCO WATER STRAINER**

For installation on the suction side of engines and pumps. ARG series strainers are designed with a durable one-piece molded sight glass to eliminate tie rods and gaskets, and construction is with bronze head castings.

38-1000M1/2" - ARG500319.00
38-1002M3/4" - ARG750339.00
38-1004M1" - ARG1000475.00
38-1006M1-1/4" - ARG1250532.00
38-1008M1-1/2" - ARG1500765.00
38-1010M2" - ARG2000829.00
38-1012M2-1/2" - ARG25001075.00
38-1016M3" - ARG30001195.00

**FULL PORT BALL VALVES**

Brass. Threaded for pipe.

38-126R1/4"6.85
38-127R3/8"6.95
38-128R1/2"8.75
38-129R3/4"13.50
38-130R1"20.95
38-131R1 1/4"29.95
38-132R1 1/2"46.95
38-133R2"68.95
38-701R2 1/2"148.95
38-705R3"195.95
38-706R4"369.95

FULL PORT BALL VALVES WITH STAINLESS STEEL HANDLE

Brass. Threaded for pipe.

38-684R3/8"7.95
38-685R1/2"9.95
38-686R3/4"14.75
38-687R1"24.95
38-688R1 1/4"34.50
38-689R1 1/2"50.95
38-690R2"90.95

316 STAINLESS STEEL VALVES

Top quality valves threaded for pipe.

38-514M3/8"17.25
38-515M1/2"17.95
38-516M3/4"25.50
38-517M1"36.95
38-518M1 1/4"54.50
38-519M1 1/2"71.95
38-520M2"114.95

**FUEL TRANSFER VANE PUMP**

Light duty, 45 min rated diesel pump with integral reversing switch. 6 gpm at 10 ft head. Self Priming up to 9 ft vertical lift. -30C to 40C operating temp. range. Duty cycle 35 min at 10 ft. Complies with USCG 183.410 and ISO 8846 Marine. Connections for 1/2" NPT.

8" long x 4 3/4" Wide x 3 3/8" High. 5.5 lbs. Approx. 8 amp draw. Recommended fuse size is 15 amps.

32-333M18680-1000, 12V635.00
---------	----------------------	-------------



1 1/2" ELECTRIC CLUTCH PUMP

A heavy duty pump constructed of bronze body, brass cams and wear plates for increased serviceability. Pump operates in either direction and comes with 7" single groove pulley for 5/8" Dia. "B" Belts. C/W Neoprene impeller. 1 1/2" Ports. Capacity - 3400 G.P.H.

32-122P.....12V(50200-9203).....1475.00
 32-123P.....24V(50200-9303).....1499.00

Replacement Parts

Impeller

32-050R.....(836-0003).....81.95

Seal

32-130P.....(21849).....139.95

Bearing

32-131P.....(92600-0040).....69.95

Cam

32-132P.....(834-0001).....86.95

Cam Screw

32-133P.....(91005-0040).....12.50

End Cover Gasket

32-134P.....(816-0000).....8.25

End Cover Screw

32-135P.....1.50

Clutch Coils

32-032P.....12V.....118.00

32-033P.....24V.....143.00



2" ELECTRIC CLUTCH DRIVEN PUMP

Bronze body, neoprene impeller. 7" single groove, 5/8" pulley. Made by Jabsco.

32-200P.....12V.....2290.00

32-201P.....24V.....2360.00

32-053R.....Repl. Impeller.....142.95

Clutch Coils

32-032P.....12V.....118.00

32-033P.....24V.....143.00



GROCO VANE PUMP

GROCO Vane Pumps are self-priming, instantly reversible, and are capable of operation in either direction. Relatively high flow (more than gear pumps) makes them suitable for general purpose duties such as deck-wash, bilge pumping (filtered inlet), fuel transfer, ballast transfer, and oil change. 1/2" NPT. Max GPM = 6.5. Breaker DC = 30 amp(12V Model)/15 amp(24V Model)

32-151P.....SPO-60-N 12V.....639.00

32-152P.....SPO-60-N 24V.....649.00



GROCO CIRCULATING PUMP

Silent running, simple to service and operate, and can handle small solids without pump damage. They provide high GPM flow but relatively low pressure. Will not self-prime; a flooded inlet is required. Max GPM is 17. Inlet is threaded 3/4" NPT. Discharge is threaded 1/2" NPT inside. Garden hose adaptor included. Motor is "Ignition Protected" and has a #316 stainless steel shaft. Continuous duty mechanical shaft seal.

32-153P.....CP-20 12V.....439.00

32-154P.....CP-20 24V.....459.00

WATER PUPPY

Cast bronze body with reusable O-ring. End cover seal. Ports have 1/2" internal pipe thread and 1" external hose barb. Includes 2 adaptors for garden hose. Self priming from 2 to 4 feet. 12V, 6.8 amps, 379 G.P.H.

32-105P.....18660-0123.....339.00

Replacement Parts

Impeller

32-119R.....(6303-0003).....36.50



1" FLEXIBLE IMPELLER PUMP

JABSCO Pedestal mount pump constructed of corrosion resistant bronze. Ideal for engine cooling, wash down or circulation. Permanently lubricated ball bearing for long life. 5/8" shaft. Self priming and can operate in either direction. To maximum speed, 3000RPM. 1" PT Ports. 1560 G.P.H.

32-018P.....777-9001.....706.00

Replacement Parts

Impeller

32-054R.....(17937-0001).....52.95

Seal

32-137P.....(96080-0080).....98.00

Bearing

32-138P.....(92600-0060).....65.10

Cam

32-139P.....(934-0000).....54.00

Cam Screw

32-140P.....(91004-0090).....4.95

End Cover Gasket

32-141P.....(890-0000).....6.25

End Cover Screws

32-142P.....(91003-0010).....8.50



1/2" FLEXIBLE IMPELLER PUMP

Similar construction to 1" model in the top right corner only has 1/2" FNPT Ports. Maximum RPM's - 3600. Capacity - 678 G.P.H.

32-017P.....01673-1001.....649.00

Replacement Parts

Impeller

32-048R.....(1210-0001).....49.95

Seal

32-143P.....(92700-0060).....42.95

Bearing

32-144P.....(18753-0130).....12.50

Cam

32-145P.....(490-0001).....64.50

End Cover Gasket

32-146P.....(1835-0000).....16.50

Screw Kit (contains 6 end cover screws plus cam screw)

32-147P.....18753-0134.....17.95

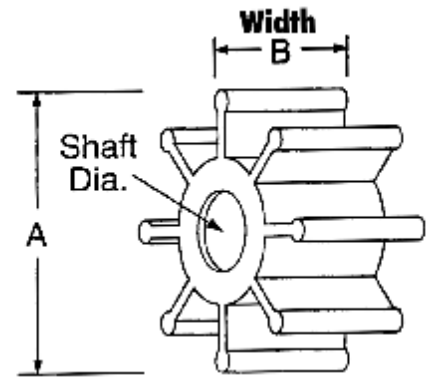

NEOPRENE IMPELLERS

Ord. No.	Model No.	No. of Fins	Diameter - A	Width - B	Shaft Dia.	Drive	Price
32-155R	4528-0001	6	1 9/16"	3/4"	3/8"	P	70.95
32-129R	18948-0001	12	2 9/16"	1 5/8"	5/8"	K	79.95
32-046R	4568-0001	12	2 1/4"	1 1/4"	5/8"	K	83.95
32-047R	4598-0001	8	2 9/16"	2"	5/8"	K	112.50
32-048R	1210-0001	12	2 1/4"	1 1/4"	5/8"	S	49.95
32-052R	17935-0001	12	3 3/4"	2 1/2"	1"	S	91.95
32-053R	17936-0001	12	3 3/4"	3 1/2"	1"	S	142.95
32-054R	17937-0001	10	2 9/16"	2"	5/8"	S	52.95
32-119R	6303-0003	6	2"	7/8"	5/16"	SF	36.50
32-050R	836-0003	9	3 3/4"	2 1/2"	1"	S	81.95

SP	SLOTTED SHAFT PIN DRIVE		
P	THROUGH HOLE PIN DRIVE		
K	KEY DRIVE		
SF	SINGLE FLAT DRIVE		
DF	DOUBLE FLAT DRIVE		
D	DING DRIVE KEYWAY		
S	SPLINE DRIVE		
RK	RIBBED SEGMENT KEY <small>Supplied on shaft type 4</small>		



MASKA V-BELT PULLEYS

MASKA Quick Mounting V-Belt sheaves are made from fine grained grey iron castings with accurately machined and polished grooves, carefully balanced to provide true running, vibration free operation. Fitted with tapered bushings, MASKA sheaves are fast and easy to install - or remove.

To form a "Complete Pulley", you require one sheave and one bushing.

All pulleys will accept 1/2" (A) Belts or 5/8" (B) Belts. Diameters shown are for "B" belts. Deduct 1/2" for "A" belts.

V-BELT SHEAVES

SINGLE

32-319P	4.2" Dia. (MBL42)	47.95
32-320P	5.2" Dia. (MBL52)	58.95
32-321P	6.2" Dia. (MBL62)	70.95
32-322P	7.2" Dia. (MBL72)	78.95

DOUBLE

32-323P	4.2" Dia. (2MBL42)	81.95
32-324P	5.2" Dia. (2MBL52)	97.95
32-325P	6.2" Dia. (2MBL62)	141.95
32-326P	7.7" Dia. (2MBL77)	132.95

TYPE "L" BUSHINGS

32-327P	5/8" Bore	19.95
32-328P	3/4" Bore	19.95
32-329P	1" Bore	19.95
32-330P	1 1/4" Bore	17.95

V-BELTS (INDUSTRIAL B-BELTS. "B" - 5/8" DIA.)

44-192P	45"	23.90	44-210P	63"	29.35
44-193P	46"	24.40	44-211P	64"	29.65
44-194P	47"	24.85	44-212P	65"	30.05
44-195P	48"	25.20	44-213P	66"	30.35
44-196P	49"	25.55	44-214P	67"	30.70
44-197P	50"	25.90	44-215P	68"	30.95
44-198P	51"	26.25	44-216P	69"	31.30
44-199P	52"	26.60	44-217P	70"	31.80
44-200P	53"	26.75	44-703P	71"	32.25
44-201P	54"	27.05	44-704P	72"	32.60
44-202P	55"	27.20	44-705P	73"	32.85
44-203P	56"	27.45	44-706P	74"	33.40
44-204P	57"	27.60	44-707P	75"	33.80
44-205P	58"	27.70	44-708P	76"	34.25
44-206P	59"	28.00	44-709P	77"	34.80
44-207P	60"	28.15	44-710P	78"	35.20
44-208P	61"	28.50	44-711P	79"	35.65
44-209P	62"	28.90	44-712P	80"	36.15



LINK BELT

Allows adjustment of approximately 1" with interlocking links. Allows you to create a belt of desired length. Sold by the foot.

44-417K	(A) 1/2"	24.95 per ft.
44-418K	(B) 5/8"	27.25 per ft.



GROCO

BRONZE INSERT ADAPTORS - STRAIGHT INSERT

Part#	Pipr Size	Hose Size	Price
38-234R	1/2"	1/2"	5.25
44-1179R	1/2"	5/8"	3.30
44-1180R	3/4"	1/2"	4.75
38-076R	3/4"	3/4"	10.75
38-077R	1"	1"	14.95
38-078R	1 1/4"	1 1/4"	26.95
38-079R	1 1/2"	1 1/2"	32.95
38-080R	2"	2"	43.95
38-720R	2 1/2"	2 1/2"	85.95
38-721R	3"	3"	116.95



GROCO

90° BRONZE INSERT ADAPTER

Part#	Pipr Size	Hose Size	Price
38-235R	1/2"	1/2"	13.95
38-236R	3/4"	3/4"	16.95
38-237R	1"	1"	25.95
38-238R	1 1/4"	1 1/4"	38.95
38-239R	1 1/2"	1 1/2"	53.95
38-240R	2"	2"	76.95
38-722R	2 1/2"	2 1/2"	132.95
38-723R	3"	3"	169.95



IN-LINE CHECK VALVES

Stainless steel spring loaded bronze poppet for positive sealing and self cleaning. 200 WOG-corrosion resistant material. Neoprene O-ring seal.

38-513R	1/2"	20.95
38-287R	3/4"	27.95
38-288R	1"	32.95
38-289R	1 1/4"	52.95
38-290R	1 1/2"	74.95
38-291R	2"	121.95



GROCO

BRONZE THRU-HULL LOCKNUTS

38-107R	1/2"	5.95
38-108R	3/4"	6.95
38-109R	1"	10.95
38-110R	1 1/4"	17.95
38-111R	1 1/2"	23.95
38-112R	2"	36.95
38-095R	2 1/2"	49.95
38-123R	3"	86.95



GROCO

BRONZE THRU-HULLS FOR PIPE

(Reg. length c/w nuts)

Part#	Size	Length	Price
38-070R	1/2"	2.20"	23.95
38-071R	3/4"	2.20"	25.95
38-072R	1"	2.85"	37.95
38-073R	1 1/4"	2.90"	62.95
38-074R	1 1/2"	3.15"	81.95
38-075R	2"	3.90"	121.95
38-328R	2 1/2"	3.56"	239.00
38-329R	3"	4.00"	339.00



GROCO

EXTRA LONG THRU-HULLS FOR PIPE

Bronze (5 1/2" long c/w nut)

Part#	Hose Size	Thread Length	Price
38-065M	3/4"	5.33"	40.95
38-066M	1"	5.33"	52.95
38-067M	1 1/4"	5.45"	84.95
38-068M	1 1/2"	5.45"	92.95
38-232M	2"	5.58"	129.95



GROCO

BRONZE THRU-HULLS FOR PIPE

Part#	Hose Size	Thread Length	Price
38-241R	3/4"	1 1/4"	33.95
38-242R	1"	1 1/4"	47.95
38-243R	1 1/4"	1 1/4"	63.95
38-244R	1 1/2"	1 1/4"	79.95
38-245R	2"	2"	104.95



Thorne Trawl

MEGA FLOW STAINLESS THRU-HULLS / HOSE

Light weight construction. Allows for larger flow. High density marine-grade #316 stainless steel ensures strength and prevents crevice corrosion.

38-691R	3/4"	32.95
38-693R	1 1/8"	36.95
38-695R	1 1/2"	42.95



GROCO

SCOOPED BRONZE THRU-HULLS FOR PIPE

Part#	Size	Length	Price
38-081R	1/2"	2.20"	39.95
38-082R	3/4"	2.20"	49.95
38-083R	1"	2.85"	67.95
38-084R	1 1/4"	2.90"	97.95
38-069R	1 1/2"	3.15"	109.95
38-802R	2"	3.60"	185.95



GROCO

GROCO STAINLESS STEEL THRU-HULLS

NPSM thread. #316 Stainless Steel.

Part#	Size	Length	Price
38-1025R	1/2"	2.20"	24.95
38-1026R	3/4"	2.20"	24.95
38-1027R	1"	2.85"	68.95
38-1028R	1 1/4"	2.90"	76.95
38-1029R	1 1/2"	3.15"	79.95
38-1030R	2"	3.90"	109.95



GROCO

GROCO STAINLESS STEEL THRUHULLS FOR HOSE

NPS Thread With Hose Connection. #316 Stainless Steel.

Part#	Size	Length	Price
38-1034R	3/4"	2.70"	38.95
38-1036R	1 1/8"	2.80"	47.95
38-1037R	1 1/2"	2.80"	94.95
38-1038R	2"	2.80"	117.95



Thorne Trawl

90° SHORT THRU HULL

Cast stainless steel construction. Ideal for limited space and can eliminate a kink in hose.

38-717R	3/4"	29.95
38-718R	1 1/8"	31.95
38-719R	1 1/2"	56.95



BRITE PLATE THRU-HULLS FOR HOSE

Brite plate Thru-Hulls offer the economy of "plastic" with the look of "Stainless Steel".

38-726R.....	3/4"	11.95
38-727R.....	1 1/8"	15.95
38-728R.....	1 1/2"	24.95



PLASTIC THRU-HULLS FOR HOSE

38-088R.....	3/4"	4.50
38-089R.....	1 1/8"	7.85
38-090R.....	1 1/2"	10.95



90° PLASTIC THRU-HULLS / HOSE

38-314R.....	3/4"	5.95
38-315R.....	1 1/8"	13.95
38-316R.....	1 1/2"	28.95



X-LONG PLASTIC THRU-HULLS/HOSE

38-229R.....	1 1/8"	8.75
38-228R.....	1 1/2"	16.50



1.5" THRU-TRANSOM SCUPPER

The rubber flapper opens to drain water out and closes to prevent backwash. Acetal construction.

For 1-1/2" I.D. hose.

Dimensions 6-1/4" L x 2-7/8" dia.

Max. Hull Thickness 3-1/8"

Installation Hole Size 2"

Caution: Thru-Hull connectors are designed for installation above the water line only.

38-310M.....	1 1/2"	26.20
--------------	--------	-------	-------

GROCO

NEW



GROCO SPANNER WRENCH

Cast bronze with stainless steel pins to fit 1/4" and 5/16" holes. Opens to service deck plates or strainer caps with key holes up to 7" apart. Hangs conveniently near the strainer(s) location.

46-135M.....	SW-2531.....	35.95
--------------	--------------	-------	-------



90° STREET ELBOWS

BRONZE

38-584R1/4"2.95
38-585R3/8"3.95
38-204R1/2"6.50
38-205R3/4"11.25
38-206R1"15.95
38-207R1 1/4"26.95
38-208R1 1/2"35.95
38-209R2"55.75

316 STAINLESS STEEL

38-587R3/8"6.50
38-340R1/2"7.21
38-341R3/4"9.73
38-342R1"15.53
38-343R1 1/4"19.12
38-344R1 1/2"22.54
38-345R2"34.92

GALVANIZED

38-588R1/4"2.15
38-589R3/8"2.15
38-409R1/2"1.85
38-410R3/4"2.89
38-411R1"4.35
38-412R1 1/4"6.65
38-413R1 1/2"8.25
38-414R2"13.25

TEES

BRONZE

38-590R1/4"4.15
38-591R3/8"6.25
38-210R1/2"8.25
38-211R3/4"13.95
38-212R1"23.50
38-213R1 1/4"35.50
38-214R1 1/2"47.50
38-215R2"73.95

316 STAINLESS STEEL

38-593R3/8"6.27
38-346R1/2"8.82
38-347R3/4"13.14
38-348R1"14.08
38-349R1 1/4"21.07
38-350R1 1/2"23.13
38-351R2"43.07

GALVANIZED

38-594R1/4"2.49
38-595R3/8"2.49
38-421R1/2"2.25
38-422R3/4"3.75
38-423R1"5.65
38-424R1 1/4"8.65
38-425R1 1/2"11.25
38-426R2"17.50

REDUCER BUSHINGS

BRONZE

38-602R3/8" x 1/4"1.09
38-222R1/2" x 3/8"1.99
38-223R3/4" x 1/2"3.50
38-224R1" x 3/4"6.25
38-225R1 1/4" x 1"11.75
38-226R1 1/2" x 1 1/4"14.75
38-227R2" x 1 1/2"20.75

316 STAINLESS STEEL

38-603R3/8" x 1/4"3.80
38-547R1/2" x 3/8"4.58
38-358R3/4" x 1/2"5.50
38-359R1" x 3/4"8.93
38-360R1 1/4" x 1"13.63
38-361R1 1/2" x 1"16.72
38-362R1 1/2" x 1 1/4"16.72
38-533R2" x 1 1/2"27.48

GALVANIZED

38-604R3/8" x 1/4"1.50
38-704R1/2" x 3/8"1.50
38-456R3/4" x 1/2"1.60
38-457R1" x 3/4"2.50
38-458R1 1/4" x 1"3.95
38-459R1 1/2" x 1 1/4"4.95
38-460R2" x 1 1/2"7.50

PIPE CAPS

BRONZE

38-597R3/8"2.95
38-467R1/2"7.50
38-468R3/4"5.85
38-469R1"9.25
38-470R1 1/4"14.50
38-471R1 1/2"18.50
38-472R2"28.50

316 STAINLESS STEEL

38-599R3/8"2.89
38-385R1/2"4.01
38-386R3/4"4.90
38-387R1"6.76
38-388R1 1/4"12.05
38-389R1 1/2"14.89
38-390R2"19.08

GALVANIZED

38-601R3/8"1.40
38-438R1/2"1.40
38-439R3/4"1.85
38-440R1"2.75
38-441R1 1/4"3.85
38-442R1 1/2"4.65
38-443R2"7.25

PIPE PLUGS

BRONZE

38-473R1/2"3.25
38-474R3/4"4.25
38-475R1"6.25
38-476R1 1/4"9.50
38-477R1 1/2"13.95
38-478R2"18.50

GALVANIZED

38-450R1/2"1.20
38-451R3/4"1.60
38-452R1"2.25
38-453R1 1/4"3.95
38-454R1 1/2"4.75
38-455R2"7.95

PIPE UNIONS

BRONZE

38-880R1/2"16.95
38-881R3/4"23.95
38-882R1"25.95
38-883R1 1/4"39.95
38-884R1 1/2"51.95
38-885R2"64.95

GALVANIZED

38-630R1/2"8.75
38-631R3/4"11.25
38-632R1"12.95
38-633R1 1/4"19.95
38-634R1 1/2"27.95
38-635R2"39.50

INSERT ADAPTORS

GALVANIZED

38-929R1/2"2.45
38-930R3/4"2.95
38-931R1"4.35
38-932R1 1/4"5.95
38-933R1 1/2"7.80
38-934R2"10.95
38-935R2 1/2"31.95
38-936R3"34.95

HOSE TO HOSE COUPLER

GALVANIZED

38-957R1/2"2.40
38-958R3/4"3.20
38-959R1"4.35
38-960R1 1/4"7.50
38-961R1 1/2"8.75
38-962R2"11.95



TEFLON TAPE

White : For sealing pipe fittings.

56-034R1/2"1.25
---------	-----------	-----------

Pink : For Gas, Oils, Propane, etc.

56-004R1/2" X 260'3.95
---------	------------------	-----------



BILGEFLEX BILGE PUMP HOSE

Shields Bilgeflex is a single layer corrugated polyethylene hose. It is resistant to mild chemicals and salt water and there is a clamping cuff every foot. This hose is primarily used for bilge pump discharge. Do not attach to thru hull fitting below the water line.

- 38-026R.....3/4"0.95 ft.
- 38-027R1 1/8"1.15 ft.
- 38-028R1 1/2"1.95 ft.



BILGEVAC BILGE PUMP HOSE

Shields Bilgevac is a black PVC hose with a flexible vinyl helix. It is very flexible, abrasion resistant and is resistant to mild chemicals and saltwater. This hose is primarily used for bilge pump discharge and drains (sinks, shower, scupper, and livewell). Do not attach to thru hull fitting below the water line.

- 38-021R.....3/4"2.15 ft.
- 38-022R1 1/8"2.75 ft.



BLOWER VENT HOSE

Vinylent Ducting Hose is PVC supported by anodized wire helix. It is resistant to UV and the ozone. This hose is primarily used for venting of bilge fumes.

- 38-795R.....3"0.95 ft.
- 38-796R.....4"0.95 ft.



SANITATION HOSE

Shields Super PVC Sanitation Hose is smooth off white PVC with a vinyl helix. It contains an anti-fungus/bacterial agent to inhibit odour causing growth. It is resistant to mild chemicals, saltwater, and permeation. This hose is primarily used for toilet to holding tank (self draining lines) and holding tank pump out. It has a five year limited warranty. Do not use ethylene glycol based anti-freeze in hose.

- CAUTION – Do not use for potable water.
- 38-030R.....1"6.50 ft.
 - 38-029R1 1/2"6.95 ft.



FUEL LINE HOSE (FIRE-ACOL)

Shields Fire-Acol 15 – Low Permeation Fuel Hose has a special design NBR tube with an embedded plastic barrier layer to limit permeation. The design of this hose provides easy coupling insertion and the NBR/PVC cover is weather and UV resistant. The hose is also polyester reinforced and fire-resistant. This hose is primarily used for fuel feed (gasoline up to 85% ethanol blended fuels/diesel/bio-diesel all blends). The temperature range is -20°F to 212°F.

- 38-032R.....3/8"3.90 ft.
- 38-033R1/2"5.25 ft.



"PREMIUM" G. PURPOSE HOSE

100% rubber. Soft and bendable, used for engine cooling, plumbing, pumping, etc.

- 38-668R5/8" I.D.4.45 ft.
- 38-669R3/4" I.D.4.95 ft.
- 38-670R1" I.D.5.60 ft.
- 38-671R1 1/4" I.D.10.95 ft.
- 38-672R1 1/2" I.D.13.50 ft.
- 38-673R2" I.D.16.95 ft.



FUEL LINE HOSE (OUTBOARDS)

Silverado 4000 Outboard Fuel Line is resistant to ethanol blended fuels. This hose is EPA and CARB compliant. Silverado 4000 has a THV barrier layer to prevent permeation, polyester reinforcement for strength and a weather and UV resistant CPE cover. The gray color keeps hose cooler and helps prevent vapor lock. This hose is for above deck primer bulb applications, and is NOT fire retardant.

- 38-035R.....3/8"2.95 ft.



FUEL TANK VENT HOSE (FIRE-ACOL)

Fire-acol fuel vent hose resists gasoline/alcohol blended fuel and is fire resistant. It features a weather/UV resistant NBR/PVC cover. This hose is primarily used for fuel vent lines (gasoline up to 85% ethanol blended fuels/diesel fuels). It meets USCG Type A2 requirements for pleasure boats and meets SAE J1527 Type A2, ISO 7840 Type A2 and NMMA/CE Type accepted standards. The temperature ranges from -20°F to 160°F.

- 38-037R.....5/8"4.25 ft.



LAY FLAT WATER DISCHARGE

100% PVC water discharge hose. Easily coiled and stored away.

- 38-674R.....1 1/2" I.D.1.19 ft.
- 38-675R.....2" I.D.1.49 ft.



FUEL FILL HOSE (FIRE-ACOL)

Shields Fire – Acol – Fuel Fill Hose resists gasoline/alcohol blends and is compounded for low permeation. It is abrasion resistant and it is reinforced with wire helix imbedded between plies of HD synthetic cord. This imported hose is primarily used for fuel fill (gas or diesel) and is for pleasure boats only. It meets SAE J1527 Type A2 and ISO 7840 Type A2 NMMA/CE Type Accepted standards.

38-173R	1 1/2"	14.95	ft.
38-174R.....	2"	20.95	ft.



FRESH WATER HOSE

All Clear Polyester Reinforced Red Tracer PVC Tubing has a clear heavy wall FDA formula vinyl. It has a polyester braid reinforcement and 250# psi burst pressure. This hose is primarily used for pressurized water system supply (hot or cold), drain lines (sink, shower, icebox), wash down pump connections and head intake.

38-786R.....	3/8"	1.20	ft.
38-787R.....	1/2"	1.59	ft.
38-788R.....	5/8"	1.85	ft.
38-789R.....	3/4"	2.19	ft.
38-790R.....	1"	3.15	ft.



HEAVY DUTY BILGE/WATER HOSE

Shields Vac Extra Heavy Duty/Commercial Grade Hose has a smooth cover and clear FDA formula PVC with a white vinyl helix. It is rated for full vacuum and is resistant to mild chemicals and saltwater. This hose is primarily used for bilge pump intake and discharge, potable water tank fill, drains (sinks, shower, and scupper), livewell intake and drain, and sanitation (intake, vent and pump out). This hose is utilized for below the waterline connections. Do not use glycol based antifreeze in hose. Do not use in pressurized water systems.

38-165R.....	3/4"	2.25	ft.
38-166R.....	1"	2.85	ft.
38-167R.....	1 1/8"	3.35	ft.
38-168R.....	1 1/4"	3.85	ft.
38-169R.....	1 1/2"	4.09	ft.
38-170R.....	2"	6.50	ft.



INDUSTRIAL GRADE WATER HOSE

Heavy duty machined brass ends. Non-marking, soft and flexible. 300psi. Temp. rating : -26°C to +66°C

38-810K.....	1/2" I.D. x 50ft.	69.95
--------------	-------------------	-------	-------



38-807



38-809

WATER HOSE NOZZLES

38-807K.....	7.95
38-809K.....	8.95



FOOT VALVES

Two piece stainless steel, spring loaded, bronze poppet with neoprene seal. Stainless steel end cap, red brass body.

38-484R.....	1/2"	17.95
38-485R.....	3/4"	21.95
38-486R.....	1"	32.95
38-487R.....	1 1/4"	46.95
38-488R.....	1 1/2"	67.95
38-489R.....	2"	105.95



www.mercersmarine.com

- Always Open
- Sale & Feature Items
- View Catalogue
- Thousands of products
- Updated Regularly
- Up to date Pricing
- Mobile Friendly
- Shop from anywhere at anytime

find us on   



HEAVY DUTY T-BOLT CLAMPS

Stainless steel construction. 3/4" wide band, stainless steel locknut with nylon insert.

Order #	Size Range	Price
38-890R	1 1/2" (1 3/8" - 1 5/8")	8.65
38-891R	1 3/4" (1 5/8" - 1 7/8")	7.85
38-892R	2" (1 3/4" - 2 1/8")	7.95
38-893R	2 1/4" (2 1/8" - 2 3/8")	7.95
38-894R	2 1/2" (2 9/32" - 2 19/32")	8.25
38-895R	2 3/4" (2 17/32" - 2 27/32")	9.25
38-896R	3" (2 25/32" - 3 3/32")	9.25
38-897R	3 1/4" (3 1/32" - 3 11/32")	8.95
38-898R	3 1/2" (3 9/32" - 3 19/32")	8.95
38-899R	3 3/4" (3 17/32" - 3 27/32")	9.50
38-900R	4" (3 25/32" - 4 19/32")	9.50
38-901R	4 1/4" (4 1/32" - 4 11/32")	9.50
38-902R	4 1/2" (4 8/32" - 4 19/32")	9.50
38-908R	4 3/4" (4 1/2" - 4 7/8")	9.50
38-903R	5" (4 3/4" - 5 1/8")	10.50
38-904R	5 1/4" (5 1/8" - 5 3/8")	10.50
38-905R	5 1/2" (5 3/8" - 5 5/8")	10.50
38-906R	5 3/4" (5 17/32" - 5 27/32")	10.50
38-907R	6" (5 3/4" - 6 1/4")	11.25



STAINLESS STEEL HOSE CLAMPS

All stainless steel including the screw.

Order #	CL #	Size Range	Price
38-326R	4	1/4" to 5/8" (Sm. band)	0.89
38-327R	6	3/8" to 7/8" (Sm. band)	0.99
38-043R	6	3/8" to 7/8"	1.09
38-044R	8	7/16" - 1"	1.09
38-280R	10	9/16" - 1 1/16"	1.09
38-045R	12	9/16" - 1 1/4"	1.09
38-046R	16	1 1/16" - 1 1/2"	1.15
38-047R	20	3/4" - 1 3/4"	1.15
38-048R	24	1" - 2"	1.15
38-264R	28	1 3/4" - 2 3/8"	1.15
38-049R	32	1 1/2" - 2 1/2"	1.19
38-281R	36	1 13/16" - 2 3/4"	1.25
38-050R	40	2 1/16" - 3"	1.30
38-051R	48	2 9/16" - 3 1/2"	1.35
38-052R	56	3 1/16" - 4"	1.40
38-053R	64	3 5/16" - 4 1/4"	1.65
38-054R	88	4 1/16" - 6"	1.95



TRANSOM EXHAUST FLANGE & FLAPS

Cast bronze with integral flange.

38-246P	3"	219.00
38-247P	3 1/2"	365.00
38-248P	4"	399.00

Rubber Flaps

Prevent water from coming back through your exhaust. C/W S.S. clamp.

38-274R	For 2 3/8" to 3" exhausts	10.95
38-275R	For 3 1/2" to 4" exhausts	12.95

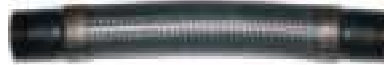

STAINLESS STEEL EXHAUST BELLOWS

Use on dry exhaust systems.

This unit absorbs dry exhaust vibrations. Manufactured from 304 or 300 stainless, it's a corrugated flex hose with stainless steel braided covering, 18" long.

Available with male pipe thread ends or welded nipples.

Welding Nipples

Order No.	Size	Price
44-1486M	2" x 18"	P.O.R.
44-1488M	3" x 18"	P.O.R.
44-1490M	4" x 18"	P.O.R.
44-1491M	5" x 18"	P.O.R.
44-1492M	6" x 18"	P.O.R.



RED RUBBER GASKET MATERIAL

Used as gasket for stern bearings, stuffing boxes and thru-hull fittings, etc. 36" wide by 1/8" thick. Sold by minimum size of 12" x 12".

44-134M	3.78 Sq. Ft.
---------	--------------



EXHAUST LAGGING

Fiberglass filled lagging. Replaces asbestos. Withstands temperatures to 1000°F. Will not rot and is oil resistant.

44-077P	3/4" Dia x 100ft Coil	P.O.R.
44-078P	1" Dia x 100ft Coil	P.O.R.



EXHAUST TAPE WRAP

Fiberglass construction. For use on exhaust systems. Will not rot and rated to 1000°F. Oil Resistant. 1/8" x 3" wide.

44-081P	100 ft. Coil	59.95
44-080P		2.29/yd



FIRE-RESISTIVE COATING

A white, fire resistive resin emulsion insulation lagging coating, which dries to a tough, flexible, weather-resistant finish. Resistant to water, mild acids, alkalis, petroleum solvents and salt solutions. Washable finish. Fire resistive. Contains fungicide. Brush consistency. Indoor or outdoor use.

52-433J	Gallon	69.95
---------	--------	-------

PAR MAX PUMPS

- Efficient, high-flow, self-priming pump serving 2 outlets
- Multi-diaphragm design self primes to 1.8m vertical lift, can run dry without damage
- Supplied with snap-in ports for hose
- Quiet running
- Motor protected by automatic thermal overload cut-out

- Includes bypass feature to provide smooth, quiet flow, No need for accumulator tank
- Connections: for 1/2" bore hose
- Dimensions: 9.1" long x 4.2" wide x 4.2" high
- Fuse Size: 10 amp



PAR MAX 2.0 PUMP

- Output: 2.0 gallons/minute open flow
- PRESSURE SWITCH - cuts out at 2.1bar (30psi)
- Maximum Current: 6.0 amps

Model 31295-3512		
32-212P12V.....	185.00
Model 31295-3524		
32-213P24V.....	229.00
Repl. Pressure Switch		
32-203P18916-1050	51.95

PAR MAX 3.0 PUMP

- Output: 3.0 gallons/minute open flow
- PRESSURE SWITCH - cuts out at 2.8bar (40psi)
- Maximum Current: 6.2 amps

Model 31395-4012		
32-214P12V.....	199.00
Model 31395-4024		
32-215P24V.....	245.00
Repl. Pressure Switch		
32-203P18916-1050	51.95

PAR MAX HD PUMPS

These Heavy Duty models feature a heavy duty motor and cast aluminum lower housing which allow for long-life, even at high pressures.

- Efficient, high-flow, self-priming pump serving multiple outlets
- Multi-diaphragm design self primes to 3m vertical lift, can run dry without damage
- Supplied with snap-in ports for hose

- Protection Class (IP Rating): IPX6
- Includes bypass feature to provide smooth, quiet flow. No need for accumulator tank

- Connections: for 1/2" bore hose
- Quiet running, smooth flow



PAR MAX 4 HD PUMP

- Output: 4 gallons/minute open flow
- PRESSURE SWITCH - cuts in at 1.7bar (25psi) - cuts out at 2.8bar (40psi)
- Dimensions: 4.7" H x 5" W x 9.6" L
- Fuse Size: 15 amp

Model Q401J-118S		
32-216P12V.....	289.00
Model Q402J-118S		
32-217P24V.....	332.00
Repl. Pressure Switch		
32-204P16470-0060	51.95

PAR MAX 5 HD PUMP

- Output: 5 gallons/minute open flow
- PRESSURE SWITCH - cuts in at ca. 3,2 bar (45 psi) and cuts out at 4,1 bar (60 psi)
- Dimensions: 4.7" H x 5" W x 9.6" L
- Fuse Size: 20 amp

Model P501J-118S		
32-220P12V.....	355.00
Repl. Pressure Switch		
32-204P16470-0060	51.95

PAR MAX 6 HD PUMP

- Output: 6 gallons/minute open flow
- PRESSURE SWITCH - cuts in at ca. 3,2 bar (40 psi) and cuts out at 4,1 bar (60 psi)
- Dimensions: 4.7" H x 5" W x 10.2" L
- Fuse Size: 25 amp

Model P601J-218S		
32-222P12V.....	385.00
Model P602J-218S		
32-223P24V.....	429.00
Repl. Pressure Switch		
32-204P16470-0060	51.95

MERCER'S
210 MARINE DRIVE, CLARENVILLE, NL

Visit us online at
www.mercersmarine.com

Our website has
Up to Date Pricing &
Live Inventory

TEL: 709.466.7430
info@mercersmarine.com

Pumps, Hoses & Plumbing

MARINE EQUIPMENT

FLOJET



HIGH VOLUME WATER PRESSURE SYSTEM WITH ACCUMULATOR TANK (4.5 GPM)

Integrated pump and accumulator tank system
 •Compact design installs easily in convenient locations
 •May be mounted vertically or horizontally •Supplies 4.5 GPM (17.0l/Min) up to 6 GPM (22.7l/Min) with fully charged tank •Can run dry without harm •FDA materials in pump and accumulator tank for drinking water •Self-priming up to 10 ft. (3.1 M) •Includes assorted ports for easy installation •Accumulator tank has total volume of 1.1 Gal. (4.1 Lt.) •Dimensions: 7.2”h x 11.3”w x 12.8”l
 •Pressure Shut Off: 40 PSI (2.8 bar)

- 32-303P.....12V, max. amps 10975.00
- 32-304P.....24V, max. amps 5999.00
- 32-299P.....115V, max amps 1.5995.00
- Repl. Pressure Switch
- 32-307P2090-10471.95

FLOJET



PRESSURE WATER SYSTEM (3.3 GPM)

Delivers smooth, steady water flow from 1 to 3.3 GPM without the need for an accumulator tank •Pumps over 3.3 GPM •Special internal bypass feature eliminates pulsating water and pressure switch chatter •Designed for up to 5 fixtures •Runs dry without harm to the pump. Self priming to 6 ft suction lift. C/W snap-in ports for 1/2” hose barb and 1/2” thread (QEST Type)

- Dimensions: 3.75”h x 6.3”w x 8.2”l •Pressure shut off 35 PSI.
- 32-296P115V, 0.4 amps@10PSI336.00
- Repl. Pressure Switch
- 32-307P2090-10471.95

FLOJET



HIGH PRESSURE WATER SYSTEM (4.5 GPM)

Flojet’s premium plus water pressure system has become a favorite for both recreational and commercial users •Self priming, smooth flow operation •Includes plug in fittings for 3/4” hose barb and 3/4” garden hose •Pump inlet strainer •270 GPH capacity •Pressure shut off 40 PSI. Self priming to 10 ft suction lift.

- 32-298P115V, 0.5 amp @ 10 PSI475.00
- Repl. Pressure Switch
- 32-307P2090-10471.95



ACCUMULATOR TANK

This Accumulator Tank is intended for installation in any pumped water system controlled by a pressure switch.

The Accumulator Tank smooths water flow and reduces on/off cycling of the pump by lessening the variation in pressure and flow between the pump and the outlets in the system.

- 32-179P30573-0000156.00

For replacement pressure switches for pumps not shown in this catalogue, please contact us with the Pump Model #



JABSCO WASHDOWN PUMP & NOZZLE (4 GPM)

12 Volt. Connections: for 1/2” and 3/4” bore hose and US GHT. Fuse Size: 20 amp. Maximum Current: 11 amps. Output: 15 litres/minute (4 gallons/minute) open flow. PRESSURE SWITCH - cuts out at 4.1bar (60psi). Efficient, high-flow, self-priming pump. Multi-diaphragm design self primes to 2.4m vertical lift, can run dry without damage. Supplied with snap-in ports for hose 1/2” and 3/4” and 3/4” US Garden Hose Thread (1 pc). Strainer and Trigger Nozzle included. IPX6 rated. Dimensions: 9.4” long, 4.2” wide, 3.8” high

- 32-315PQ401J-118N-3A279.00
- Repl. Pressure Switch
- 32-204P16470-006051.95



INLET WATER STRAINER

Keeps debris from entering your water system. Features stainless steel, 40 mesh screen and transparent threaded cover, allowing for easy cleaning. 1/2” hose barb ports.

- 32-313P33.75



MANUAL GALLEY PUMP

Chrome plated zinc alloy, plastic body, above base 5” high, full body 10” high, use 3/8” hose. Manual operation.

- 32-076R69.95



STAINLESS STEEL ROUND SINK

10 1/4" I.D. x 11 1/2" O.D. x 7 1/8" Deep
32-118R.....159.00



STAINLESS STEEL ROUND SINK

9 7/8" I.D. x 11 1/2" O.D. x 5" Deep
32-117R.....115.00



BARKA RECTANGULAR SINK

13" x 13" x 7" Deep
32-205K.....304.00



GALLEY FAUCET

An exceptional quality faucet constructed of heavy-duty chrome plated brass with swivel spout. 1/2" male pipe thread. Uses 1/2" coupling and insert adaptor to connect to 1/2" hose.

32-074P.....82.00

Adaptor fitting

Adapts above faucet from 13mm to 1/2" hose barb.
32-160P.....5.25



TWIN FAUCET

Same high-quality as single faucet(32-074). This unit is designed for boats with hot and cold water systems. Comes with adaptor for 1/2" male pipe thread. Uses 1/2" coupling & insert adaptor to connect to 1/2" hose.

32-075P.....133.00



SINK DRAIN

Drain fits both "Round" sinks above. Designed for 5/8" hose.

32-077K.....28.50



FLUSH MOUNT SHOWER UNIT

Manufactured from high tech plastic material. Flush mount design allows for installation in transom or head. Spray shower head comes with water conserving button and 10' of hose. 10.3" W x 5.75"H x 4.65"D.

32-334P.....299.00



HOSE ADAPTOR

38-265P.....1 1/2" pump to 1 1/8" hose.....13.95

IN-LINE CHECK VALVES

Prevents water back flow.

38-700P.....Heavy Duty, 1 1/2" hose.....34.50

32-103P.....Medium Duty, 1" and 1 1/2" hose.....8.95



SHOWER & BASIN FAUCET

An attractive style faucet for use in either basin or shower. Hot/Cold. Pull out flexible extension hose is approx. 4' in length. Supplied with 2 fittings which accept 1/2" NPT coupling.

32-065M.....172.00



WHALE FAUCET/SHOWER COMBO

Ideal for tight interior spaces. Robust ABS construction. For pressure or microswitch systems. For use with all types of galley pumps. Multi-function spray head with 1.7 m retracting hose. Water flow can be temporarily shut off on shower head.

•Hose Size: 1/2" Threaded •Depth beneath surface: 3-1/8" •Base plate: 6-3/4" x 2-1/2"

32-064K.....149.95



500/800 GPH BILGE PUMPS

These pumps offer quality features while keeping size to a minimum. These Rule pumps are unmatched in pumping power and longevity. Uses 3/4" discharge outlet.

500 GPH
Dimensions: 3.9" high x 2.5" x 2.9"
32-081P12v, 1.6 amps52.95

800 GPH
Dimensions: 4.37" high x 2.5" x 2.9"
32-090P12v, 3.4 amps82.95



2000 BILGE PUMPS

Engineered to commercial standards, the rule 2000 is the best selling, high capacity, submersible pump in the world. 1 1/8" discharge outlet.

32-084P12v, 8.4 amps254.00
32-085P24v, 4 amps279.00
32-086P32v, 3.1 amps279.00
32-098PRepl. Strainer16.95



1100 BILGE PUMP

Submersible, ignition protected. Built-in thermal cut-off provides added protection for pump and vessel. Stainless steel shaft. Uses 1" or 1 1/8" discharge hose.

Dimensions: 4.37" high x 2.5" x 2.9"
32-082P12V, 3.7 amps93.95



1500 BILGE PUMP

High pumping capacity and reliability at a lower cost. More exclusive design features than any comparable competitive pump. 1 1/8" discharge outlet.

32-083P12V, 4 amps182.00
32-098PRepl. Strainer16.95



3700 BILGE PUMPS

Heavy duty construction for both commercial and pleasure boat use. 1 1/2" discharge outlet. For automatic use, a "Superswitch" is recommended.

32-012P12v, 15.5 amps, 3700 gph419.00
32-013P24v, 6.9 amps, 3500 gph441.00
32-014P32v, 5.0 amps, 3500 gph436.00
32-099PRepl. Strainer15.95



GENERAL PURPOSE PUMPS

This model is designed for use as a washdown pump, but can also be used for fire fighting. This unit is not self priming and must be mounted below the waterline. Although not designed as a high pressure pump, it delivers lots of water.

Requires 1 1/2" intake and discharge hose.
32-015P12v, 15.5 amps, 3800 gph468.00
32-314P24v, 6.9 amps, 3700 gph479.00
32-016P32v, 5.0 amps, 3700 gph522.00



RULE-MATE AUTOMATIC BILGE PUMPS

Automatic Bilge Pumps feature a pump and a non-mercury float switch in a single, compact housing. There is no on/off cycling and therefore, no power use until the pump comes on. The pump remains on until the float drops and the pump senses no load against the impeller.

1 1/8" discharge hose.
32-337P12v, 4.8 amps, 1500 gph379.00
32-338P12v, 8.4 amps, 2000 gph489.00
32-339P24v, 8.4 amps, 2000 gph499.00



ECO-FRIENDLY RULE-MATE AUTOMATIC BILGE PUMPS

Connections: For 3/4" or 1" bore hose on inlet and outlet. Straight or 90° Elbow. Fully automated bilge pump with integral sensor. Back up feature to prevent dry running if sensor is fouled, pump reverts to 2.5 minute cycle mode. Compact pump for smaller vessels. Back flow prevention to reduce the amount of water left over in the bilge. Quick release inlet strainer allows rapid cleaning. Ignition protected and built in thermal cut-off.

32-335P12v, 1.8 amps, 500 gph119.95
32-336P12v, 3.8 amps, 1100 gph211.95



LOPRO 900 GPH BILGE PUMP

900 GPH Low Profile Bilge Pump. Fits in hard to reach places. Threaded discharge ports with multiple fittings available (3/4", 1" & 1 1/8"). Features a tricuspid check valve to minimize back flow of water. Height of the pump is only 2-1/4". The entire discharge body swivels up to 180° for ease of installation. The hose attached can also swivel 360° to route the hose perfectly.

Non-automatic, requires float and or panel switch to automate.
32-024P12V, 4 amps93.95
Automatic
32-025P12V, 4 amps126.50



DRY BILGE PUMP - 4GPM

Drains the bilge almost dry. Filter-free design. Self-priming to 9.5'. Able to run dry without damaging the pump. Up to 4.0 GPM flow. Back flow prevention. Connections for 3/4" hose barbs. Rotating pump head and ports. Compact and simple design. 3/4" (19 mm), plastic, 90° thru-hull fitting included.

32-236P DB412, 12V, 8 amps.....429.00



LIVEWELL PUMP "STC" TOURNAMENT SERIES

Removable motor cartridge. For Thru-Hull Applications Straight 4 3/4" (121mm) Pickup Tube. Flow Rate 800 gph (3028 lph). Discharge 1 1/8 inch (28.6 mm). Voltage 12 Vdc. Amp Draw 2.8 amp. Fuse Size 5.0 amp.
32-355PModel 403-STC (Straight)107.50



LIVEWELL PUMP "C" TOURNAMENT SERIES

Removable motor cartridge. For Thru-Hull Applications Angled 4" (102mm) Pickup Tube. Flow Rate 800 gph (3028 lph). Discharge 1 1/8 inch (28.6 mm). Voltage 12 Vdc. Amp Draw 2.8 amp. Fuse Size 5.0 amp.
32-357PModel 403-C (90 degrees).....107.50



RULE-A-MATIC FLOAT SWITCH

Year after year this switch is the choice of most yachtsmen, commercial fishers and boatbuilders the world over. For use with pumps drawing up to 14 amps.

32-091P69.95



SUPERSWITCH

The RULE Super Switch is designed for the toughest applications. Good for all voltages up to 110v. Sets the industry standard. C/W built-in fuse.

32-011P 101.50



ECO SWITCH

An ecologically sound automatic bilge pump switch, featuring non-mercury design. As water rises in the bilge, air is forced up the tube which is attached to the switch. The air pressure activates the switch and controls the pump. There are no moving parts, all wiring is out of the water and there are no submerged electrical connections. For pumps drawing up to 20 amps.

32-350P12V.....117.00

32-351P24V.....120.00



RULE IN-LINE SUBMERSIBLE PUMP 500GPH

Multi-application submersible for water and diesel. Delivers 500GPH. Pumps fresh, sea water and diesel. Rapid diesel refueling and transfer with no spillage. Easy pump-out in tight areas. **water transfer; deck showers; general wash-down; baitwell tank aeration.** Robust, slim-line with clip on easily cleaned filter. Continuous duty. Pump size 1 1/2" Dia x 6 1/2"L. Supplied with 13 ft of hose and power cable. Removable shut-off nozzle for inline installation if required.

32-168P Pump Only, 12V, 6 amps.....115.50

32-169PComplete Pump Kit.....169.00





RULE INFLATOR/DEFLATOR PUMP

Inflates a typical four man dinghy in as little as 50 seconds. 12v, 25amps, maximum. 2.6psi, 20 CFM. 10ft.cable length with battery clips. Pre-lubricated and sealed bearings to ensure long life. Supplied with an adaptor for all major inflatable boats. Grip pad for one handed operations.

32-175P	12V	142.00
32-176P	Inflator Adaptor Kit	19.50



AMAZON UNIVERSAL HAND DIAPHRAGM PUMP

The Amazon hand pump from Jabsco gives 1320 gph flow rate. Excellent solids handling capability. Quick release clamp ring gives quick access for blockage clearance. Includes one push-fit elbow which swivels 360 degrees for flexible installation. Connections for 1-1/2" hose. Comes with detachable handle.

32-162P	189.00	
Replacement Parts		
32-165P	Universal Thru-deck kit	35.50
32-166P	Addition push-fit 90 degree elbow	21.50
32-167P	Diaphragm Service Kit	51.95



HAND PUMP

Deluxe Rule Model

Consists of ABS plastic with comfortable grip handle. 1-1/2" diameter. 24" in length. Hose not included. 1-1/8" required.

32-080P	96.50
---------------	-------

Imported Model

Plastic construction with removable foot valve for easy cleaning. 24" overall length. Supplied with 36" of 1-1/8" hose.

32-070P	28.95
---------------	-------



ECONOMY HAND PUMP

Nylon. For 1" & 1.5" hose.

32-041R	44.95
---------------	-------



- Always Open
- Sale & Feature items
- View Catalogue
- Thousands of products
- Updated regularly
- Up to date pricing
- Mobile friendly
- Shop from anywhere at anytime

www.mercersmarine.com

Also find us on





HIGH WATER BILGE ALARM

This unit consists of a float switch and an indash gauge that features visible & audible alarms. This unit allows unmanned compartments to be constantly monitored. For additional compartments just add a Rule-A-Matic switch.

- 32-094P12 volt139.00
- 32-106P24 volt139.00



3-WAY BILGE PUMP SWITCH PANEL

Very attractive rocker switch design. Controls any pump equipped with an automatic float switch. This unit features a black plastic panel, has a built-in fuse holder and an internally lighted rocker switch with 3 positions (automatic, off, or manual) with Rule "fail-safe" spring return to "off" from the "manual" position.

- 32-294P12V63.95



3 WAY BILGE PUMP SWITCH PANEL

Controls any pump equipped with an automatic float switch. Toggle has 3 positions (automatic, off, or manual) and has a "fail-safe" spring return to "off" from the "manual" position. Panel is black stainless steel and has red indicator light and fuse holder.

- 32-092P12V62.50
- 32-093P24V & 32V64.95



WATERPROOF BILGE PUMP SWITCH

3-position rocker switch has auto/off and spring control to manual position. Comes with indication LED's. Uses AGC fuses. Aluminum face plate is 2"W x 3 1/2"H.

- 32-037R12V15.95



ROTARY BARREL PUMP

Diamond brand

Comes with pipe and 8' of vinyl discharge hose. 18L per minute capacity.

- 32-067M69.95



3-WAY BILGE PUMP SWITCH

Material: ABS, Black. Voltage: 12VDC. Auto-Off-Manual switch with spring return from manual position.

- 3 1/4" x 2 7/16"
- 32-039R25.95



3-WAY BILGE PUMP SWITCH AND ALARM

Material: ABS, Black. Voltage: 12VDC. Auto-Off-Manual switch with spring return from manual position. Has bilge level alarm. 4 1/2" x 2 7/16"

- 32-040R32.95



ENGINE OIL CHANGE PUMP

Comes with 1/4" hose to fit dipstick hole. Brass and neoprene construction.

- 32-066R26.95



ELECTRIC DRILL PUMP

A great little pump from JABSCO designed to pump most liquids and especially useful for Engine Oil Changes. This pump will pump hot oil and comes with 3' of 1/2" discharge hose and 40" of 1/4" hose suitable for dipstick hole. Two 3/4" garden hose adaptors are also supplied. Fits into 1/4" or 3/8" drill. Drill not included.

- 32-110PCap. - 200 GPH89.95



"LITTLE PAL" UTILITY PUMP

Compact multi purpose hand pump does many draining and liquid transfer jobs, yet small enough to fit into a tool box. Includes 2 feet of hose and draw tube for draining crank case oil through dipstick tube.

- 32-332P99.95



SHOWER DRAIN BOX

A compact, full capacity shower drain system. Automatically turns on after the water starts, and shuts off when the water is removed. Activated by a Rule-A-Matic® float switch. Other features include a clear screw down cover, a removable strainer for easy cleaning, and an internal check valve to prevent back flow.

- Flow rate : 800GPH. Discharge : 3/4".
- 3 Inlet Ports Accept 3/4", 1", 1 1/8" & 1 1/2"
- 32-348P12V258.00
- 32-349P24V265.00



MANUAL MARINE TOILET

This Jabsco Manual Toilet is both functional and stylish. The pump assembly is angled forward to provide a natural smooth stroke while the convenient dry bowl selector is easy to operate. The base assembly is fully skirted to eliminate the debris traps associated with most toilets. The 2" pump body is made of white cycloac and can be installed on the left side if required. All fasteners are stainless steel and bronze.

1 1/2" outlet & 3/4" intake.

Compact Bowl (17 3/4" W x 16 3/4"D x 13 1/4"H)
 38-146P29090 – 3000**345.00**

Regular Bowl (18 5/16" W x 19 1/4"D x 13 5/8"H)
 38-150P29120 – 3000**375.00**

REPLACEMENT PARTS FOR JABSCO TOILETS

Complete pump assembly for above model	
38-147P	195.00
Service kit for above model 29090 toilet including all valves, o-rings, gaskets, etc.	
38-148P	For 29090-3000 Model141.00
Toilet Base complete with plug and o-ring assembly for above 29090 toilet.	
38-646P	84.95
Seat, lid & hinge set for all Jabsco toilets shown	
38-282P	109.95



ELECTRIC MARINE TOILET

This Jabsco Electric Toilet is equipped with a dual function pump which eliminates having to mess with hand pumps and dry bowl valves. With the simple push of a button the self priming flush pump rinses the bowl as the macerator pump grinds up waste and pumps it out. Includes heavy-duty push button switch and 1 1/2" to 1" adaptor for discharge hose. 3/4" inlet, 1" outlet.

Compact Bowl (17 3/4" W x 19 3/4"D x 13 3/4"H)
 38-152M12v (37010-0090)**849.00**
 38-153M24v (37010-0096)**895.00**

Household Bowl (19 3/4" W x 21 3/4"D x 14 5/8"H)
 38-158M12v (37010-1090)**895.00**
 38-159M24v (37010-1096)**895.00**

SEAL & GASKET SERVICE KIT	
38-155M	37040-000099.00
REPLACEMENT PARTS	
38-277M	12v 37064-0000 motor285.00
38-278M	24v 37065-0000 motor323.00
38-285M	37020-0000 switch96.50
COMPLETE MACERATOR KIT (MOTOR INCL.)	
38-750M	12v #37041-0010449.00
38-751M	24v #37041-0011485.00
Replacement Impeller	
32-119R	6303-000336.50

The JABSCO Electric Toilet is designed to lift water to a height of 4 feet. For installation where the toilet is located more than 4 feet above the waterline, an inline auxiliary pump may be required. Inquire.



SEALAND 510+ FLUSH TOILET

This toilet is designed to operate with an independent outside water source. Many options are available in different voltages. Please inquire! This unit is a large toilet with a 3" discharge outlet. When the water source is provided, you simply raise the side lever to the required amount of water then press the lever to flush. A standard 5" floor flange which accepts 3" ABS pipe is optional. Color: White

38-741KToilet**659.00**

Replacement Parts for 510+	
38-745K	Floor flange.....35.95
38-744K	Water Valve Kit (#314349)79.95
38-746K	Spring Cartridge Kit (#236096)62.95
38-748K	Ball & Shaft Kit (#318162)109.95
38-743K	Pedal Cover Kit (#310114)61.95
38-747K	Floor flange Seal Kit (#310063)47.95

Replacement Parts for Sealand 310 ONLY	
38-735K	Water Valve Kit (#311641)79.95



MACERATOR PUMP

These pumps are the ideal answer to simple holding tank pumpouts. The macerator section grinds waste into small particles so it easily passes through the pump's 1" hose barbed discharge port. The pumps are self-priming and can empty a typical 30 gallon (115 litre) holding tank in less than 3 minutes. The intake port with 1 1/2" NPT can be screwed directly into a tank's female discharge fitting or the pump may be positioned remotely for installation versatility.

38-284P12 volt**350.00**
 38-302P24 volt**375.00**



VENTED LOOPS

Used where toilets are installed below the waterline to prevent siphoning.

Cast Bronze Construction
 38-233P 3/4"**84.95**
 38-156P1 1/2"**184.95**
Nylon Construction
 38-157K1 1/2"**44.95**



Y-VALVES

For a quick changeover in pumping waste either overboard or into holding tank. Also useful for pumping two bilges with one pump.

Jabsco model - Lockable
 38-283P1 1/2"**145.00**
Imported model (Plastic)
 32-062R1"**17.95**
 32-063R1 1/2"**18.95**



DOMETIC 962 PORTABLE TOILET (2.5 GAL)

The simple, self-contained and adult-sized SaniPottie 962 Portable Toilet provides recreational boaters with convenience and user-friendly performance. The bellows-style flush delivers a bowl-clearing rinse every time. Its durable, easy-to-clean construction and secure locking side latches ensure a reliable performance for a long time. 2.5 gal. (9.5L) waste tank capacity. (12 1/2" H x 14 1/2"W x 16 1/2"D)

38-730PModel 301096206.....179.00

Powerful Flushing at the touch of a button without constant pumping or batteries. High-strength ABS . Prismatic tank level indicator allows easy tank level monitoring construction withstands harsh environments; smooth, easy-to-clean finish. Push-button flush clears bowl instantly. Full-size seat for comfort; latching lid for security.



Push Button Operation

DOMETIC 972 PORTABLE TOILET (2.8 GAL)

(12 1/2" H x 13 2/16"W x 15 1/4"D)

38-736PModel 301097206.....269.00



Rear View

DOMETIC 974MSD PORTABLE/PERMANENT TOILET (2.6 GAL)

•Includes mounting brackets, discharge and vent fittings for permanent installation

(12 1/2" H x 13 2/16"W x 15 1/4"D)

38-737PModel 301197406.....359.00



Push Button Operation

DOMETIC 975 PORTABLE TOILET (5 GAL)

(15 1/4" H x 13 2/16"W x 15 1/4"D)

38-738PModel 301097506.....369.00



Rear View

DOMETIC 975MSD PORTABLE/PERMANENT TOILET (5 GAL)

•Includes mounting brackets, discharge and vent fittings for permanent installation

(15 1/4" H x 13 2/16"W x 15 1/4"D)

38-739PModel 301197506.....399.00



TOILET TREATMENT (320Z)

Toilet chemical for holding tanks. Non-formaldehyde, non-staining, biodegradable formula allows pump out at any dumping station. Lubricates drain valves. One ounce treats five gallons.

52-282RLemon.....27.95

RACOR. DIESEL FUEL FILTER/WATER SEPARATORS

"Fuel is your biggest expense, don't make it your biggest headache as well"; install a RACOR Filter in your fuel line today. We have models from 30 GPH to 360 GPH. RACOR's Turbine Series are available in single or double manifold series which allows for isolation of one unit, while servicing the other.

You can determine your engine's approximate fuel flow rate by using this simple formula: Fuel Flow = HP x 0.18

RACOR.



MODEL 500 FG

Flowrate: 60 GPH. 3/4" - 16 SAE Ports.

Complete with 2 micron element. Plastic bowl.

44-144M..... 459.00



MODEL 900 FH

Flowrate: 90 GPH. 7/8" - 14 SAE Ports.

Complete with 2 micron element. Plastic bowl.

44-148M..... 649.00



MODEL 1000 FH

Flowrate: 180 GPH. 7/8" - 14 SAE Ports.

Complete with 2 micron element. Plastic bowl.

44-151M..... 725.00

RACOR.



MODEL 500 MA

Flowrate: 60 GPH. 3/4" - 16 SAE Ports.

Complete with 2 micron element. Plastic bowl, comes with metal shield.

44-654M..... 565.00



MODEL 900 MA

Flowrate: 90 GPH. 7/8" - 14 SAE Ports.

Complete with 2 micron element. Plastic bowl with metal shield.

44-655M..... 850.00



MODEL 1000 MA

Flowrate: 180 GPH. 7/8" - 14 SAE Ports. Complete with 2 micron element. Plastic bowl with metal shield.

44-596M..... 815.00



RACOR.



MODEL 75/500 FGX

Flowrate: 120 GPH, 3/4" - 16 SAE Ports, pressure differential gauge and isolation valve, complete with 2 micron elements. Plastic bowls.

44-541K..... 1895.00



MODEL 75/900 FHX

Flowrate: 180 GPH, 7/8" - 14 SAE Ports. Complete with pressure differential gauge and isolation valve. C/W 2 micron elements. Plastic bowls.

44-1366K..... 2695.00



MODEL 75/1000 FHX

Flowrate: 360 GPH, 7/8" - 14 SAE Ports. Complete with 2 micron elements with pressure gauge and isolation valve. Plastic bowls.

44-578K.....2795.00

Fuel Filters & Engine Acc.

RACOR.



MODEL 75/500 MAX

Flowrate: 120 GPH, 3/4" - 16 SAE Ports, Complete with pressure differential gauge and isolation valve. C/W 2 micron elements. Plastic bowls with metal shields.

44-598K.....2095.00



MODEL 75/900 MAX

Flowrate: 180 GPH, 7/8" - 14 SAE Ports. Complete with pressure differential gauge and isolation valve. C/W 2 micron elements. Plastic bowls with metal shields.

44-804K.....3095.00



MODEL 75/1000 MAX

Flowrate: 360 GPH, 7/8" - 14 SAE Ports. Complete with 2 micron elements with pressure gauge and isolation valve. Plastic bowls with metal shields.

44-597K..... 3075.00

RACOR.



RACOR AQUABLOC ELEMENTS

Always rely on Racor Aquabloc replacement elements. Elements are available in 2, 10, and 30 micron protection ratings. The lower the micron rating, the finer the protection. The 2 micron element (SM) is for secondary/final filtration and has brown end caps. The 10 micron element (TM) can be used for primary or secondary/final filtration and has blue end caps. The 30 micron element (PM) is for primary filtration and has red end caps.

MODEL 500 REPLACEMENT ELEMENTS PARTS

44-145M2010SM, 2 micron (Brown)20.95
44-797M2010TM, 10 micron (Blue).....20.95
44-798M.....2010PM, 30 micron (Red).....20.95
Replacement Parts
44-146Mrepl. bowl with seal169.95
44-147Mdrain valve with seal.....83.95

MODEL 900 REPLACEMENT ELEMENTS PARTS

44-149M.....2040SM, 2 micron (Brown)21.95
44-799M2040TM, 10 micron (Blue).....21.95
44-800M.....2040PM, 30 micron (Red).....21.95
Replacement Parts
44-150Mrepl. bowl with seal139.95
44-147Mdrain valve with seal.....83.95

MODEL 1000 REPLACEMENT ELEMENTS PARTS

44-152M2020SM, 2 micron (Brown)25.95
44-801M2020TM, 10 micron (Blue).....25.95
44-802M.....2020PM, 30 micron (Red).....25.95
Replacement Parts
44-150Mrepl. bowl with seal 139.95
44-147Mdrain valve with seal..... 83.95

MARINE EQUIPMENT



SIERRA TURBINE SERIES RACOR REPLACEMENT ELEMENTS

Filters offer lift tabs on top of end cap for easy removal. Sierra's fuel water separating media is OEM tested & approved. Replacements offered for 500, 900 & 1000 turbine series. Available in 2, 10 & 30 micron ratings. Matches Original manufactures colour codes. All Sierra filters are designed to meet or exceed engine manufacturers requirements.

500 SERIES REPLACEMENT ELEMENTS

- 90-340R2 micron (Brown) #18-9918615.95
- 90-341R10 micron (Blue) #18-9918215.95
- 90-342R30 micron (Red) #18-9918315.95

900 SERIES REPLACEMENT ELEMENTS

- 90-343R2 micron (Brown) #18-9919117.95
- 90-344R10 micron (Blue) #18-9918517.95
- 90-345R30 micron (Red) #18-9918417.95

1000 SERIES REPLACEMENT ELEMENTS

- 90-346R2 micron (Brown) #18-9918723.95
- 90-347R10 micron (Blue) #18-9918120.95
- 90-348R30 micron (Red) #18-9918020.95



MODEL 230

Flowrate: 30 GPH. 1/4" NPT Ports. Complete with 2 micron element. Plastic bowl.

- 44-141M295.00
- Replacement Element & Parts For Model 230 Filter**
- 44-656M.....Repl. Element (R20S - 2 Micron)44.95
- 44-147M.....Drain Valve83.95
- 44-143MRepl. Bowl (For Models 220/230)185.00



Metal Bowl

Clear Plastic Bowl

UNIVERSAL GAS FILTER / WATER SEPARATOR

Universal inboard or I/O gas filter. A multi-port head allows easy installation anywhere in engine compartment. 1/4" NPTF ports. Flowrate: 60 GPH. Complete unit includes mounting head, metal bowl and element.

Metal Bowl

- 44-153MModel 320-RAC-02199.95
- 44-154MReplacement Element S-3228UL46.95

Clear Plastic Bowl

- 44-155M320-RAC-01159.95
- 44-156MReplacement Element S322748.95



UNIVERSAL IN-LINE FUEL FILTER

A quality Racor Filter is suitable for O/B motors and other installations where fuel contamination can be troublesome. Designed for gas or diesel. 1/4" female NPT ports.

- 44-657MModel 025/RAC-02234.95
- Replacement Element**
- 44-658MS25-0258.95



SIERRA FUEL FILTERS

Sierra AquaVue and metal bowl separator filters allow water to be drained from the filter to extend service life. Use the AquaVue bowl for outboard, above deck installations. Use flame resistant metal bowl below deck. Comes with 1/4" pipe plugs.

- 90-300PAquaVue Bowl (Clear)116.00
- 90-301PMetal Bowl173.00

- 90-305PReplacement Element33.95
- 90-307PReplacement Clear Bowl42.95



SPIN ON ELEMENT

For Model 220 Filters
R24 S - 2 micron element.

- 44-142M49.95

PERKO



PERKO P-TRAP VENT VALVE

Stainless steel escutcheons, aluminum shaft & polymer body with splash guard and flame arrestor. Allows vapor to vent from tank during thermal expansion of fuel and while refueling. Allows fresh airflow into the tank during thermal contraction of fuel and when engine is running. Protects canisters and fuel systems from water. Deflector style vent opening reduces water volume entering assembly. Internal P-Trap and check valve prevents water from passing through assembly into fuel system. Straight hose connection.

5/8" hose. Max Hull thickness 1"

38-149R.....58.00

PERKO



PERKO 1 1/2" COMBINATION FILL & TANK VENT

Chrome plated bronze cap with black plastic base and straight neck. Vent hose 5/8".

38-293R.....Gas.....85.65
38-294R.....Diesel.....85.65
38-295R.....Water.....85.65



PERKO DECK PLATE KEYS

Fits "Perko" deck fills above.

38-144R.....1 1/2" Perko Deck Fill.....7.35
38-145R.....2" Perko Deck Fill.....8.90

PERKO



"PERKO" DECK FILLS FOR PIPE

Our most popular Commercial Quality Deck Fill. Plain cast bronze. Complete with key. Unmarked.

38-134R1 1/2"166.40
38-135R2"248.05

REPLACEMENT COVER

38-267R1 1/2"110.35
38-268R2"161.50

REPLACEMENT O-RING SEALS

46-566P.....2"12.90 pk/2

PERKO



PERKO 1 1/2" COMBINATION FILL & TANK VENT

Black plastic construction with integral tank vent with flame arrestor. No deck key or ground wire required. Flip top cap.

38-139R90° neck - Gas.....42.70
38-140R90° neck - Water.....42.70
38-141R35° angled neck - Gas.....42.70

PERKO



PERKO 1 1/2" DECK FILLS FOR HOSE

Chrome plated brass deck plate. Excellent quality, comes with O-ring and key.

38-136R.....Gas.....180.75
38-137R.....Diesel.....180.75
38-138R.....Water.....180.75



DECK FILLS FOR HOSE

316 Stainless, C/W key. (Not from Perko)

1 1/2" MODEL
38-642R1 1/2" Gas.....56.95
38-643R1 1/2" Diesel.....56.95
38-644R1 1/2" Water.....56.95
2" MODEL
38-639R2" Gas.....69.95
38-638R2" Diesel.....69.95
38-640R2" Water.....69.95



1 1/2" NYLON DECK FILL FOR HOSE

A nylon deck plate, very economical. Comes with I.D. labels.

38-286R1 1/2"12.50



PERKO 1 1/2" LOCKABLE DECK FILL (HOSE)

Chrome plated zinc with black plastic flange and cap. Lockable cap has cover for keyhole. C/W 2 keys.

38-506R.....Gas.....85.60



FUEL TANK VENTS

Chrome Plated Brass

38-142R90° x 5/8" hose.....20.95
38-143R.....Straight x 5/8" hose.....20.95
38-624RStraight x 1/2" NPT.....21.95

Fuel Filters & Engine Acc.

MARINE EQUIPMENT



HOSE TO ENGINE FITTINGS

FUEL LINE ASSEMBLIES

HOSE TO TANK FITTINGS

Approx. OL Length = 7ft

Keep your fuel lines operating at peak performance to insure your outboard motor runs smoothly. Moeller offers a wide variety of OE compatible replacement assemblies.



OMC
48-011R058227.95

OMC Hose Kit
3/8" I.D. hose Bombardier (Johnson/Evinrude) fuel line assembly.
48-003R0748649.95

OMC
48-011R058227.95



Yamaha
48-010R058157.95

Yamaha Hose Kit
3/8" I.D. hose Yamaha fuel line assembly.
48-004R0748949.95

Yamaha
48-010R058157.95



New Merc.
48-070R057917.25

New Style Merc. Hose Kit
3/8" I.D. hose Mercury two prong clip style fuel line assembly. 1998 and newer engines.
48-002R0748251.95

New Merc.
48-012R057937.50



FEMALE PIPE ADAPTORS

44-382P3/4" - 16 SAE x 3/8"FNPT2.25
44-916P3/4" - 16 SAE x 1/2"FNPT4.25
44-917P7/8" - 14 SAE x 1/2"FNPT3.95
44-918P7/8" - 14 SAE x 3/4"FNPT6.95

BRASS HOSE COUPLERS

HOSE BARB TO MALE PIPE

44-1169R1/8" NPT x 1/4" hose1.09
44-1170R1/8" NPT x 3/8" hose1.09
44-1171R1/4" NPT x 1/4" hose1.19
44-1172R1/4" NPT x 5/16" hose1.39
44-1174R3/8" NPT x 5/16" hose2.45
44-1173R1/4" NPT x 3/8" hose1.19
44-1175R3/8" NPT x 3/8" hose1.89
44-1177R1/2" NPT x 3/8" hose2.95
44-1176R3/8" NPT x 1/2" hose1.99
44-1178R1/2" NPT x 1/2" hose3.25
44-1179R1/2" NPT x 5/8" hose3.30
44-1180R3/4" NPT x 1/2" hose4.75

90° ELBOW HOSE BARB

44-1181R1/8" NPT x 1/4" hose2.95
44-1183R1/8" NPT x 3/8" hose3.65
44-1184R1/4" NPT x 1/4" hose2.85
44-1186R1/4" NPT x 3/8" hose3.25
44-1187R1/4" NPT x 1/2" hose6.15
44-1189R3/8" NPT x 3/8" hose3.50
44-1190R3/8" NPT x 1/2" hose4.60
44-1191R1/2" NPT x 3/8" hose4.25
44-1192R1/2" NPT x 1/2" hose6.50

3.2 US Gal



6.6 US Gal



3 US Gal



6 US Gal



9 US Gal



PORTABLE FUEL TANKS

Portable tanks are lightweight, with stout handles for easy transport. Tanks are non-corrosive, unbreakable, and dent resistant. Features 90 degree 1/4" NPT fuel withdrawl elbow that rotates 360 degrees eliminating a kinked fuel line hose. Includes mechanical direct-sight gauge with easy to read indicator.

48-021R.....	3.2 US Gal.....	79.95
Dimensions 14.25"L x 10.25"W x 9"H		
48-022R.....	6.6 US Gal.....	89.95
Dimensions 21.25"L x 14"W x 9.75"H		
48-090R.....	9 US Gal.....	109.95
Dimensions 22.9"L x 14.30"W x 11.75"H		

NEPTUNE OUTBOARD MOTOR TANKS

Non-corrosive "Neptune" tanks are tough and light weight with baffled, manually vented closure caps and a universal 1/4" NPT fuel pick-up adapter. Meets ABYC standards. ISO and CSA certified.

48-029R.....	3 gal.....	52.95
Dimensions 16.75" L x 10.75" W x 8.00" H		
48-030R.....	6 gal.....	61.95
Dimensions 20.50" L x 12.75" W x 10.50" H		

FUEL TANK CONNECTORS

Screws into O/B tanks at top of page



48-006R	04068	10.95
---------------	-------------	-------



48-008R	04075	11.50
---------------	-------------	-------



48-056R	05837	13.95
---------------	-------------	-------



48-074R	18-80400	13.95
---------------	----------------	-------



48-067

Replacement Cap/Funnel Kit

JERRY CANS

Virtually indestructible, manufactured from high-density, unbreakable polyethylene that is rustproof, crush-resistant and noncorroding.

48-017K	6.6 US Gallons (16.5"H x 9.5"W x 13.75"D)	22.50
48-035K.....	5.3 US Gallons (15.5"H x 9.75"W x 11.75"D)	19.95
48-019K.....	5.3 US Gallons TALL (18"H x 7"W x 13"D)	24.50
48-018K.....	2.5 US Gallons (SELF VENTED) (11.5"H x 7.5"W x 11.25"D)	12.50
48-016K.....	1.25 US Gallons (SELF VENTED) (9.75"H x 6.25"W x 8.5"D)	9.75
48-067K.....	Replacement Cap/Funnel Kit	7.50



20 US Gal



12 US Gal



TOPSIDE FUEL TANKS

Topside fuel tanks have a manually vented fuel cap which ensures easy gripping with exclusive ribbed design that floats. Features 90 degree 1/4" NPT fuel withdrawal elbow that rotates 360 degrees eliminating a kinked fuel line hose. Includes mechanical direct-sight gauge with easy to read indicator. **ATTN: 20 gal tank uses 1/4" NPT fitting (This tank will not accept outboard Fuel Tank Connectors).**

20 US GALLON

Dimensions 28"L x 15"W x 12.37"H
48-025R.....579.00

12 US GALLON

Dimensions 24.3"L x 18.1"W x 10.75"H
48-092R.....118.95

DIESEL JERRY CAN 5.3 GALLONS

Virtually indestructible, manufactured from high-density, unbreakable polyethylene that is rustproof, crush-resistant and noncorroding.

Dimensions: 15.5"H x 9.75"W x 11.75"D

48-034K5.3 US Gallons.....19.95



42-840

"SWINGARM" ELECTRIC FUEL SENDERS

Gather fuel level information the same way as the mechanical sending units. It connects to a dash mounted gauge without a conversion capsule. Internal components will not rust or corrode.

For Tanks 6" to 12"
42-812R.....035722-1049.95
For Tanks 12" to 24"
42-813R.....035729-1052.95

"REED SWITCH" ELECTRIC FUEL SENDERS

Collect fuel level information more consistently than swingarm senders. They achieve this by taking the measurement from the float(which is a moving part). However, the fluctuation is much less because the range of motion is much less. Stainless Steel construction provides efficient performance.

For Tanks 7"
42-815R.....035774-10114.95
For Tanks 9"
42-816R.....035761-10118.95
For Tanks 11"
42-817R.....035762-10119.95

FUEL INDICATOR KIT

Complete fuel sending kit. Easy to install, great accuracy, and great looks at an economical price. For tanks from 4" to 24".

42-229RKit.....149.95
42-840R.....Gauge Only (57902P)57.95
42-228R.....Fuel Sender Only (90424P)67.95



SHUT OFF VALVE

1/4"FNPT Female/Female Brass shut-off. Meet ABYC H-24 requirements and provide anti-siphon protection.
48-095R.....1/4" FNPT.....51.95



PRIMER BULBS

Original equipment quality. UV and alcohol resistant. Fits 3/8" diameter hose. Use stainless steel clamps.

48-013R.....13.95



MOTOR FLUSHERS

For use with outboards or inboard/outboards with side wall inlets. Flushes away salt by connecting to a fresh water garden hose.

46-542R..... 6.95



HEAVY DUTY DUAL FEED MOTOR FLUSHERS

A customer-favorite for all engines over 50 HP. Improved water flow with rectangular cups will virtually eliminate water leakage for higher-pressure flushing. For use on all lower units with side water inlets; includes Volvos.

46-541R..... 39.95



2 IN 1 FUNNEL

Plastic funnel with strainer. 5 1/2" dia. Comes with a 10" flexible extension spout.

48-014M..... 4.50



DURAMAX 14 GAL PORT-A-TANK SYSTEM

Composed of a durable, high density polyethylene in vibrant red for use with gasoline, diesel, or kerosene fuels. Comes complete with a patented Flo n' Go hand pump and pump holder handle. Sturdy 152mm wheels make maneuverability a breeze over rough terrains. Dual mechanical shut-off valves, at both tank and hose, for spill proof Flo n' Go disconnection. Meets D.O.T. and UN transportation requirements.

48-027M.....215.00



MILITARY STYLE WATER CAN

Easy to tie to stanchions & railings. Small footprint takes up less room. Complete with rear vent. CSA / Standards Australia /UN certified. Self venting spout included

48-036K5.3 US Gallons.....21.95



48-040



48-041

9" FUNNEL WITH STRAINER

Plastic funnel with strainer. 4.09 litre capacity. Rugged and flexible. Available with or without anti-splash guard.

48-040MWithout anti-splash 17.50

48-041M.....With anti-splash 16.50



JERRY-BUDDY

The outboard engine adaptor for all vented fuel cans. Will connect any standard fuel cell to supply any outboard engine. No more spills from can to can transferring from inside a moving boat. Attach this easy to use supply line instead. You can provide a tension free connection for your snap on style adaptor, or bypass it all together and connect any standard size marine fuel line with whats included in this kit.

48-050M.....41.95



4 PIECE FUNNEL SET

48-015M..... 2.95



FUNNEL

Tapered rim. 8" diameter.

48-039M..... 16.95



NEW



NEW



NEW

ALUMINUM OUTBOARD MOTOR BRACKET (35HP)

Up to 35hp - 263 lbs max - 10" of lift - 2 or 4 stroke engines

Adjust to five vertical running positions for changing water or load conditions. The anodized aluminum bracket is built to handle the increased weight and torque output of today's four strokes with long or short shafts. Hand-adjustable with just the turn of a knob, stainless steel torsion springs counterbalance motor weight making adjustments a breeze, while the 2"-thick, extra-wide mounting board, along with aircraft-type stainless steel hardware deliver heavy-duty performance.

90-320P.....Model 55-0410.....459.00

ALUMINUM OUTBOARD MOTOR BRACKET (35HP)

Up to 35hp - 263 lbs max - 16" of lift - 2 or 4 stroke engines

Adjust to four vertical running positions for changing water or load conditions. The anodized aluminum bracket is built to handle the increased weight and torque output of today's four strokes with long or short shafts. Hand-adjustable with just the turn of a knob, stainless steel torsion springs counterbalance motor weight making adjustments a breeze, while the 2"-thick, extra-wide mounting board, along with aircraft-type stainless steel hardware deliver heavy-duty performance.

90-322P.....Model 55-0416.....585.00

ALUMINUM OUTBOARD MOTOR BRACKET (15HP)

Up to 15hp - 132 lbs max - 10" of lift - 2 or 4 stroke engines

Adjustable outboard motor bracket is designed for 2- and 4-stroke motors up to 15 HP or 132 lbs. Constructed of hard-coat anodized aluminum and hand adjustable with the turn of a knob. Stainless steel torsion springs counterbalance the motor weight making adjustments a breeze. 10" of travel and 5 vertical running positions let you fine tune the motor height for optimal performance. Meets ABYC Standards.

90-324P.....Model 55-0407AL.....429.00



NEW



NEW



NEW

STAINLESS STEEL HD OUTBOARD MOTOR BRACKET

Up to 15hp 4-stroke or 20hp 2-stroke
132 lbs max - 11" of lift

Adjustable Stainless Steel outboard motor bracket. Works with 4-Stroke motors up to 15hp or 2-Stroke motors up to 20hp, max weight 132lbs. Twist-knob Safety Locks provide increased torque rating while helping secure bracket in place. Built extra-tough and extra-wide for secondary, higher-torque, four-stroke engines. Motor's weight is counterbalanced by heavy-duty stainless steel torsion springs for easy lifting. Boasts a 2" thick, weatherproof and maintenance-free polypropylene mounting board along with aircraft-type stainless steel hardware. Four-position lock bar and 11" of travel allow for a better range of trim adjustment. Meets ABYC Standards.

90-326P.....Model 55-0408S.....499.00

ALUMINUM OUTBOARD MOTOR BRACKET

Up to 20hp - 115 lbs max - 11" of lift - 2 stroke engines

The adjustable bracket is designed for motors up to 20HP or 115 lbs max weight. Heavy duty, light weight aluminum is designed for fresh water use on both power boats and sail boats. Manual operation means no power is required to raise and lower your auxiliary outboard motor. Spring loaded (11" of travel with 5 stops).

Motor pad is 8.5" x 10.5" x 1.75"
90-328P.....Model 55-0021.....318.00

SWIM PLATFORM OUTBOARD MOTOR BRACKET

Up to 20hp - 2 & 4 stroke engines

Constructed of black powder coated aluminum and can be adjusted to fit most platform heights and motor shaft lengths for optimum prop depth and performance. Comes complete with transom support bar for weight support and torque resistance.

90-330P.....Model 55-0030.....499.00



NEW

FIXED OUTBOARD MOTOR BRACKET

Up to 35hp - 263 lbs max - 2 & 4 stroke engines

Rugged Polypropylene mounting board (2" thick). Includes stainless steel mounting hardware and safety cable.

90-334P.....Model 55-0028.....195.00



ECONOMY STAINLESS O.B. MOTOR BRACKET

304 Stainless Steel. Rated for lighter engines up to 20 H.P. (Not recommended for heavy 4 stroke). Plastic board size 8 1/4"W x 10 3/8"H x 2"Thick.
 46-950PModel 72533.....359.00



ECONOMY ALUMINUM O.B. MOTOR BRACKET

Rated for lighter engines up to 20 H.P. (Not recommended for heavy 4 stroke). Plastic board size 8-1/4"W x 10-3/8"H x 2"Thick.
 46-401PModel 72534.....289.00

FULTON



OUTBOARD MOTOR LOCK

Keep your Outboard motor safe and secure with the FULTON Outboard Motor Lok. Heavy-duty barrel key lock mechanism for maximum security. Foam filler insert reduces noise and vibration. Mounts on most outboard motors.

46-665P58.95



ANGLED TRANSOM SAVER

MD Angled Adjustable Reach Transom Saver. Adjusts from 30" to 60". Unique angle adjustment from 0 to 36 degrees (in 12 degree increments). Locking feature prevents unintentional detachment. Heavy duty rubber pads prevent scratching on the lower unit
 46-667P.....Model 460.....219.95



OUTBOARD MOTOR EXTENSION HANDLE

Outboard Engine Extension Handle, Telescopic Type. 25" to 45". Material: Aluminum Tubing & Plastic Handle. Size: 28.5mm(O.D.) Tubing
 46-397P16.95



DELUXE OUTBOARD MOTOR EXTENSION HANDLE

Telescopic Type and twist and lock. Material: Aluminum Tubing & Plastic Handle. Extends 24" to 52.75". Twist lock extensions with foam grip. Corrosion-Resistant construction and comfortable grip. Unique U-Joint swivel 360° for control or converts to rigid straight extension with the twist-lock sleeve.
 46-400P.....44.95



HEAVY DUTY TRANSOM SAVER

Protect your investment with Attwood Transom Savers. A lifted outboard puts hundreds of foot-pounds of pressure on the transom - especially during trailering. Support the cantilevered weight of the motor. Stabilize engine and steering mechanism when trailering
 46-666PModel SP-400099.95



NEW



BOARDING LADDERS

Aluminum with pvc steps. Approx Step Width 12". Approx Step Height 11"

24-200R.....	3 step	64.95
24-201R.....	4 step	79.95

NEW



3 STEP TELESCOPIC LADDER

304 Stainless steel. 11" Wide. 14.75" long when stowed. 34.65" long when deployed.

24-202R.....	189.95
--------------	--------

LOCK



TELESCOPING DROP LADDER

3 step telescoping ladder conveniently folds over flat on platform for storage. Step treads have plastic covering for safety and comfort. Made from 304 polished stainless steel. 32" deployed, 14 1/2" stowed, 12" wide.

24-030P.....	209.00
--------------	--------

NEW



LOCK



OUTBOARD SWIM PLATFORM

Designed for outboard boats. High density polyethylene platform measures 15 1/2"L x 18"W x 15 1/2"D. Uses one 1" stainless steel wrap around rail and one underside rail. Reversible. Available with or without ladder.

24-060P	with ladder	455.00
24-059P	without ladder	275.00

UNDER PLATFORM LADDER

Stainless steel. Extended length 35", width 11.4". Assembled 14.5". Three steps.

24-112R.....	3 step	249.00
--------------	--------------	--------



SAFETY LADDER

Bag pulls open and ladder unfolds instantly, helping a person get back onboard. Bag is canvas with one handle to attach the bag alongside the boat and another for the person fallen overboard to grab.

50-040P.....	4 Step Ladder	139.95
50-041P.....	5 Step Ladder	164.95



SEAPOST SIERRA PILOT SEAT PACKAGE

The SeaPost Sierra standard marine pilot seat has been proudly serving marine customers for over 15 years. It offers complete adjustability and ergonomic support for ultimate occupant comfort. A "Best Value" product has been enjoyed by many SeaPost customers.

- Molded, enhanced-formula foam for better fit and increased comfort
 - Built-in adjustable lumbar support
 - Adjust backrest from 90° to 125°
 - Flip-up armrests: 3 angle positions
 - Suspension seat cushion for shock reduction
 - 6" fore/aft adjustment
 - 6" pedestal height adjustment
 - 4 seat angle positions
 - Swivel 360° (locks in every 45°)
 - 3 footrest height options
 - Easy fold-up footrest (0° - 90°) with anti-skid surface
 - 3 fixed base height options: 2", 7", and 11"
 - Floor slide options available - quick-release floor slide movement
 - Marine grade trim material: Vinyl & Cloth
- | | | |
|---------------|-------------------|--------|
| 24-240K..... | Black Vinyl | P.O.R. |
| 24-241K | Black Cloth | P.O.R. |



HIGH BACK HELM SEATS

Offshore quality Helmsman seat. Fold up armrests with angle adjustments. Built in lumbar support. Serpentine seat springs isolate shock from heavy seas while high density seat cushions are padded and contour molded for added comfort. Seat Size including arm attached: 24" W x 21"D x 34 1/2"H

Seat without Arms

- 24-250K.....Black Vinyl (NO ARMS).....P.O.R.
- 24-251K.....Black Cloth (NO ARMS)P.O.R.

Arms

- 24-253KBlack Vinyl ArmsP.O.R./pair
- 24-254KBlack Cloth ArmsP.O.R./pair



SEAPOST SIERRA TORSION ASSEMBLY & COVER

Attaches to Seapost Sierra Seat. DOES NOT ATTACH TO SEAPOST MODULE OR BASE ASSEMBLY (24-258 and 24-260).

The high strength torsion bar is an engineering marvel allowing 4" of shock absorbing ride zone. Built in damper smooths out the roughest ride. Front hand wheel adjusts the weight control of this mechanical suspension seat to isolate shock and operate smoothly between 110 and 275 pounds. 7" fore and aft slide offers finger tip adjustment. Serpentine seat springs isolate shock from rough seas while seat cushions and padding are contour molded for added comfort

- 24-262K.....P.O.R.



HIGH BACK HELMSMEN SEAT "MODULE"

7" fore and aft travel with fingertip adjustment. Fold up footrest adjusts to 3 height positions. Adjustable seat tilt allows 4 different positions. 9" diameter polymer swivel is the largest and most dependable made and assures dependability in heavy seas.

Module Size: 18" High

- 24-258K.....P.O.R.



SEAPOST MEDIUM BASE ASSEMBLY

Base Assembly Size: 19 1/2" W x 19 1/2"D x 8"H

- 24-260K.....P.O.R.

SEA POST REPLACEMENT PARTS

Sea Post replacement covers are available. Contact us for further information.



FISH PRO 1 FOLD-DOWN SEATS

Premium high quality upholstery & cushions, durable light weight injection molded frame. Designed to provide maximum comfort & support. Concealed pinch proof hinges allow the seat to fold down when not in use.

Universal mounting 5"x 5" & 5"x 12"

Seat dimensions: 26.5"H x 19.5"W x 23.5"D

24-490P.....Grey/Charcoal.....485.00 24-491P.....Grey/Blue.....485.00

PREMIUM SKIPPER FOLDING SEATS

Contour lumbar cushion cradles your back for maximum support. Designed for style, comfort and durability.

Folds down easily. Injected plastic frame. Folds down easily. T-nuts installed into seat for better mounting durability. Universal mounting pattern: 5" x 5"

24-524P.....Charcoal/Grey.....425.00

24-523P.....Blue/Grey.....425.00



DOUBLE BUCKET SEAT

Bench seating for two. Unique flip back feature allows for fore and aft seating. Thick foam padding covered in marine grade vinyl over a high-strength composite substrate. Works with pedestals or box style mounting. Provides 35-1/2" of seating area.

Seat dimensions: 21"H x 41"W x 24"D

24-538P.....White.....1195.00



SWINGBACK COOLER SEAT

Back rest conveniently flips in either direction. Thick foam. Padding covered in marine grade vinyl. Seat/Lid opens up to cooler, keeping your drinks and food fresh all day. Aluminum rails with stainless steel hardware.

72 qt.

Seat dimensions: 37" H x 32" W x 18-1/2"D

24-539M.....1399.00



HIGH BACK FOLDING SEATS

Now a comfortable cushioned seat to support your backside. Durable upholstery, folds easily, strap with snap to keep seat secure. Rigid injection molded frame. Heavy-duty aluminum powder coated hinges. Swivel not included. Seat dimensions: 21.5"H x 16"W x 15.5"D

24-517P	Blue/Grey	189.00
24-518P	Grey/Charcoal	189.00
24-519P	Red/Grey	189.00
24-520P	White/Blue	189.00
24-521P	Camo	219.00



ECONOMY FOLDING SEATS

Now a comfortable cushioned seat to support your backside. Durable upholstery, folds easily, strap with snap to keep seat secure. Rigid injection molded frame. Heavy-duty aluminum powder coated hinges. Swivel not included. Seat dimensions: 19"H x 16"W x 15.5"D

24-509P	Off White	149.00
24-510P	Red	149.00
24-511P	Blue	149.00
24-512P	Grey	149.00
24-516P	Camo	185.00



TRAVELER FOLDING SEATS WITH CUSHION

Super strong copolymer frame. Extra wide contoured seat with curved back. Durable strap holds seat closed when folded down. Swivel not included. Seat dimensions: 14"H x 20"W x 18"D

24-498P	White Shell/Blue-White Cushion	179.95
24-499P	Grey Shell/Charcoal-Grey Cushion	179.95
24-500P	Grey Shell/Blue-White Cushion	179.95
24-501P	White Shell/Solid Blue Cushion	179.95
24-504P	Camo	179.95



FIRST MATE SEAT

First mate molded seats are one piece molded shells, made from PP plastic. Durable and lightweight, for years of care free use.

Universal Mounting Pattern 5" x 5".

Seat Dimensions: 15"H x 17.5"W x 15.5"D

24-508PGrey59.95



DELUXE CAPTAIN'S SEAT

Perfect for riding out rough conditions. High density foam cushions for maximum comfort. Plastic durable frame with anodized aluminum arms and back support bars. Foam padding covered in marine grade vinyl. Armrests are padded 3" thick. Seat Dimensions: 19"H x 24"W x 20"D

24-585PWhite525.00



24-586PBlack525.00



TRAVELER FOLDING SEAT WITHOUT CUSHION

Super strong copolymer frame. Extra wide contoured seat with curved back. Durable strap holds seat closed when folded down. Swivel not included.

Seat Dimensions: 14"H x 20"W x 18"D

24-505PWhite149.95



YACHTSMAN MOULDED SEAT

Designed for comfort, durability, and good looks. Springfield Marine's "Yachtsman" Chair comes complete with a reinforcing plate on the bottom & a removable cushion set.

Seat dimensions: 17"H x 21.5"W x 16"D

24-580PWhite325.00



DELUXE SPORT SEAT

Premium high quality upholstery and cushions for maximum support and comfort. Blow Molded Frame with molded foam. Weather resistant marine grade vinyl. Universal mounting pattern: 5" x 5" and 5" x 12" Seat dimensions: 24.5"H x 15"W x 19.5"D

24-575PWhite/White695.00

24-576PWhite/Charcoal695.00



DRINK HOLDER SET

Suction cup type. I.D. 2 3/4" PVC

46-946R9.50 pr.



IN-DASH DRINK HOLDERS

Stainless Steel In Dash with Drain

46-1017R ...3 1/2" H x 2 5/8" D x 3 7/16" I.D.12.95



LED DRINK HOLDER

LED Drink Holder, with 3 x 5mm LEDs. 12VDC, Made of S.S. 304. 3.5"(Opening I.D.); 3"(Depth); 2 11/16"(Base Dia.) 3/8" drain tube

46-1023RBlue LED17.95

46-1024RRed LED17.95



DRINK HOLDERS

Plastic Folding

Constructed of tough plastic. Folding side mount style.

46-064RBlack5.25

46-065RWhite5.25



SEAT PEDESTALS AND TOP SPIDER

Pedestals are made of anodized aluminum tubing 2 7/8" dia. – base dia. is 9".

- 24-054P9" Fixed205.00
- 24-058P18" Fixed229.00
- 24-004P18" – 24" Adj.....309.00
- 24-005P30" Fixed272.00



TOP SPIDER

Fits any 2 7/8" diameter pedestal.

- 24-048P92.00



ADJUSTABLE ACTIVE SEAT ABSORBER

Absorbs and minimizes up to 75% of the shock, jolt, and vibration transmitted to the passenger from the forces of roll, pitch, and yaw. Reduces the feelings of seasickness and nausea by absorbing excessive movement with 1" of damped vertical travel.

- 24-001P 325.00



STAINLESS STEEL SEAT SWIVEL

Heavy duty design with the offshore market in mind. Rotates 360° - fits most standard seat hole patterns. Self lubricated non-corrosive poly swivel bearings.

Fits Garelick seats. Will fit some Springfield seats. Please inquire.

- 24-020P7502064.50



SEAT SWIVEL

360° Seat swivel. Fits all our seats. Ball bearing construction. **Fits Garelick seats. Will fit some Springfield seats. Please inquire.**

- 24-047P6" x 6" (75016)31.50



SEAT SLIDE

This unit allows the boat seat to travel fore & aft. Mounts between seat & pedestal.

- 24-095P8 1/2"W x 13"L, 7" travel218.00



ADJUSTABLE SEAT SWIVEL CLAMP

Accepts standard boat seats, fits tank or bench tops. Durable – All metal construction. Quick mounting and dismounting, includes 360° swivel. Vinyl covered clamps.

- Width adjusts from 8" - 18"
- 24-049P139.95



STOWABLE TABLE PEDESTALS

Allows removability of dinette tables. Constructed of anodized marine aluminum. Special design assures solid table. Post is 2 1/4" O.D.

- 24-055P28 3/4" Post77.95
- 24-056PFlush Mount Base84.95
- 24-057PSurface Mount Base85.95



STAINLESS TABLE BRACKET

This stainless steel bracket set allows removal / replacement of table with ease. C/W 2 wall plates and 2 brackets. 3 3/4"L x 2"W x 3/4"H.

- 46-325R 18.95 ea.



ADJUSTABLE FOOT REST

Fits any 2 7/8" pedestals. Cast aluminum construction with non-slip strips for footrest.

- 24-006P 299.00

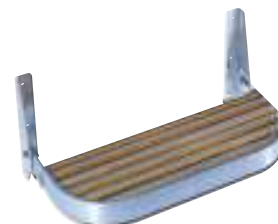

TEAK FOOTREST

Heavy duty wrap around aluminum extrusion with brushed anodized aluminum & teak inserts. 7 1/2"H x 15"W x 8 1/4"D.

- 24-043P325.00



SPRINGFIELD SEAT SLIDE/MOUNT

2-7/8" post mount with bushing for snug fit. Made of high-strength aluminum. Large 7-1/4" x 13" seat mounting platform, travels 5-1/4" forward and backward on self lubricating pads. Centrally located locking handle, easy to reach with left or right hand. Rotates 360°. Adds 1-1/4" to height of pedestal. For use with 2-7/8" pedestals

24-568P193.00



SPRINGFIELD "NON-LOCKING" TRAC-LOCK SWIVEL

2-7/8" post mount with bushing for snug fit. Made of high-strength aluminum, with powder coat finish. Rotates 360° Adds 3/4" to height of pedestal. For use with 2-7/8" pedestals.

24-569P83.00



SPRINGFIELD "LOCKING" TRAC-LOCK SWIVEL

2-7/8" post mount with bushing for snug fit. Made of high-strength aluminum, with powder coat finish. Centrally located locking handle, easy to reach with left or right hand. Rotates 360°. Adds 3/4" to height of pedestal. For use with 2-7/8" pedestals.

24-570P96.00



SPRINGFIELD FIXED HEIGHT PEDESTAL

14" Locking Anodized Pedestal With 9" Round Polished Base. Use With 2-7/8" Locking Trac-Lock Slide Or Swivel.

(sold separately). Overall height is 14-1/2" before attaching slide or swivel.

24-565P155.00



SPRINGFIELD SLIDE & SWIVEL PEDESTALS

2-7/8" Locking Pedestal With 9" Round Base, Anodized Finish. Includes Locking Trac-Lock™ Slide & Swivel.

24-557P12" Height269.00

24-558P18" Height309.00

24-559P24" Height389.00



SPRINGFIELD SEAT SWIVEL CLAMP

Seat Clamp Adjusts From 8" To 19" To Fit Most Bench Seats. E-Coated Steel To Resist Corrosion.

24-050R73.95



SPRINGFIELD SEAT SUSPENSION

High-Strength Aluminum Seat Mount. Mounts To Deck. Heavy-Duty Springs Provide A Comfortable Ride.

24-548P136.95



SEAT SWIVEL

6-3/4" Square x 1-1/8" High, With 4 Hole Mounting Pattern. 0-Degree Non-Locking Swivel. Rotates 360° Mild Steel E-Coat Finish. Also fits most Garelick and Wise seats. Some exceptions may apply.

24-550P28.95



SPRINGFIELD STAINLESS STEEL SWIVEL

6-3/4" Square x 1-1/8" High, With 4 Hole Mounting Pattern. 0-Degree Non-Locking Swivel. Rotates 360° Stainless Steel.

24-551P92.00



REMOVABLE BRACKET

Non-Locking 7" x 7" Removable Seat Bracket. Fits "Springfield" swivel to the left. Marine Grade Black Plastic.

24-553P31.95

DIAMOND / SEA-GLAZE

Diamond Sea-Glaze windows are known world wide for quality. We can supply sizes and types for most vessels.

Offshore ocean-going to inshore recreational, Diamond Sea-Glaze has the right window for you.

Below see some sketches of common types of windows.

Call us for additional information.

Special Order Custom Styles

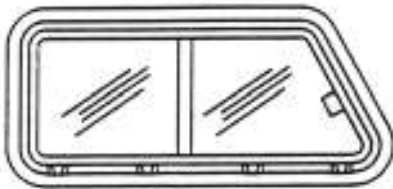

HORIZONTAL SLIDER



FIXED - MITERED OR RADIUS CORNERS



HALF DROP OR FULL DROP

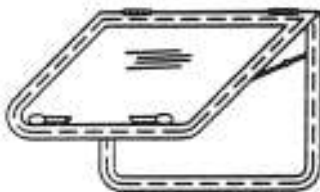

FULL VENT



1/3 & 1/2 VENT



Outside view of Right hand dutch door (Old type lockset & Door Division)



Outside view of Left hand dutch door (New type lockset & Door Division)

Mercer's Marine is your exclusive Atlantic Canada distributor of Diamond Sea-Glaze windows and doors.

•We can "custom order" your size requirements, please allow approx. 10 weeks for delivery.

•We keep the following "common sizes in stock" for immediate delivery. **Check our website for pricing.**

WEATHER TIGHT INSULATED DOORS

Diamond Sea-Glaze weather tight aluminum doors are pre-hung in a frame and are double skin constructed. Comes with gasketed seams, stainless steel hinges and tightening dogs. Includes lockset with 2 sets of keys on floating key ring. Mill finish. 4" radius corners.

R250 Double Panel Doors (Dutch)

Ord. No.	Hinged	Cut Out Size	Price
34-097K	Right Hand	20"W x 55"H	P.O.R.
34-098K	Left Hand	20"W x 55"H	P.O.R.
34-173K	Right Hand	20"W x 67"H	P.O.R.
34-174K	Left Hand	20"W x 67"H	P.O.R.

34-093K	Right Hand	24"W x 62"H	P.O.R.
34-094K	Left Hand	24"W x 62"H	P.O.R.

34-079K	Right Hand	28"W x 66"H	P.O.R.
34-080K	Left Hand	28"W x 66"H	P.O.R.

34-171K	Right Hand	32.5"W x 66"H	P.O.R.
34-172K	Left Hand	32.5"W x 66"H	P.O.R.

R250 Single Panel Door

Ord. No.	Hinged	Cut Out Size	Price
34-095K	Right Hand	24"W x 62"H	P.O.R.
34-096K	Left Hand	24"W x 62"H	P.O.R.
34-083K	Right Hand	28"W x 66"H	P.O.R.
34-082K	Left Hand	28"W x 66"H	P.O.R.

INFORMATION GUIDE

We can supply custom made doors and windows in most sizes. When ordering, please advise us on "Cutout Size". This is also known as "Rough-Stud Opening". To determine if you require a left or right hand door, note the following: When viewing the door from "OUTSIDE" your vessel, HINGES on the left indicate LEFT HAND door, HINGES on the right indicate RIGHT HAND door. Remember, these marine doors open "OUTWARDS" only. Powder Coating available by special order. Allow 10 weeks delivery.

Available by special order. DSG "Sliding Doors". Please call for details.

DIAMOND / SEA-GLAZE

ANODIZED ALUMINUM MARINE WINDOWS

Features: •Windows glazed with 6mm glass •Extruded aluminum frames •Clear anodized finish •Water tight seals
 •Flanged for 7/8" wall thickness, with inside clamp-on trim ring •Dimensions given are cut out size (rough stud opening)
 •Please note: Window photos show outside window frame •Inside finished trim rings are included in price.
 •Quality window designed for inshore vessels. **Check our website for pricing**



RECTANGULAR FIXED

24"W x 18"H.	
34-077K	P.O.R
28"W x 20"H.	
34-076K	P.O.R



SHAPED SLIDERS

30" long length x 22 3/4" short length x 20" high. For use on starboard side with long length at bottom or port side with long length at top.

34-073K	P.O.R.
For use on port side with long length at bottom or starboard side with long length at top.	
34-072K	P.O.R.



SQUARE FIXED

20"H x 20"W.	
34-085K	P.O.R



RECTANGULAR SLIDER

28" wide x 20" high, can be used either on port or starboard side. Can be installed horizontally or vertically.

34-074K	P.O.R.
---------------	--------



SQUARE SLIDER

20"H x 20"W. Can be used port or starboard, vertically or horizontally.

34-075K	P.O.R.
---------------	--------

PLEASE NOTE
 No slider window is 100% watertight in all sea conditions. The track in which the glass slides must be drilled with a small bit to allow water drainage. Call for details.



Beckson



RECTANGULAR PORTS

Durable white ABS construction. Features: watertight neoprene gasket, stainless steel hardware and self-draining. Opening models come complete with screens. Opening ports have 1" spigot on interior. Non-opening ports have 2" spigot.

34-030P	7" x 14" opening	379.00
34-031P	7" x 14" non-opening	286.00
34-032P	5" x 12" opening	324.00
34-033P	5" x 12" non-opening	251.00

Beckson



BECKSON PORTS

Opening Model

Same description as model above. (With Screen)

34-034P	8" dia	322.00
---------------	--------------	--------

Beckson



BECKSON FIXED PORTS

34-035P	6" dia	51.50
34-036P	8" dia	82.00



FIXED PORT

Economical non opening port. 304 Stainless Steel construction. Approximately 15" x 5"

34-026R	79.95 ea
---------------	----------



“ANCHOR” BRAND DECK HATCHES

- Meets ISO 12216 Standards (Under 80 feet).
- Stainless steel corrosive-free frame
- Marine grade aluminum corrosion-resistance plate
- Anti-corrosion design: no chemical reaction from aluminum to stainless steel contact.

- Anti-slip surface safety pattern
- Watertight
- Secure sealing system
- Installs flush with deck

Order No.	Clear Opening	Deck Cutout	O.D. Flange	Price
34-124K	10" x 10"	12 1/2" x 12 1/2"	15 1/2" x 15 1/2"	438.00
34-125K	14" x 22"	16 1/2" x 24 1/2"	19" x 27"	599.00
34-126K	22" x 22"	24 1/2" x 24 1/2"	27" x 27"	802.00
34-127K	18" x 28"	20 1/2" x 30 1/2"	23" x 33"	799.00
34-128K	22" x 28"	24 1/2" x 30 1/2"	27" x 33"	959.00
34-131K		Stainless Socket Wrench		89.00
34-133K		Gasket Material/Per Foot		8.95/ft.



10" ROUND ANCHOR HATCHE

- Anodized Aluminium cover and frame, stainless steel compression latches (Quick Release).
- Clear opening: 9"
- Deck cut-out: 10 1/2"
- Over deck flange: 12"

34-123K.....420.00



BOMAR GASKET MATERIAL

Fits all "BOMAR" hatches above. Peel off adhesive.

34-084K 13.95 /ft.

www.mercersmarine.com



- Always Open
- Sale & Feature items
- View Catalogue



- Thousands of products
- Updated Regularly
- Up to date Pricing



- Mobile Friendly
- Shop from anywhere at anytime

Also find us on





Freeman Marine hatches are used on a wide variety of fishing boats, tugs, barges, rescue craft and other workboats. The hatches are fast acting and easy to use. Simply grasp the handle and pull, the shaft slides into place, and with less than a quarter turn, completely disengages the locking mechanism. The dogs and linked handle do the work smoothly in just a second. Our easy lift system allows simple removal. With the locking mechanism disengaged, the hatch is resting on the deck ring and can be lifted out with one hand.

- Watertight hatches are designed to seal up to 30 foot intermittent head, the double sealing gasket seals tighter under pressure.
- Dogging mechanism assures smooth consistent action, no binding or jamming.
- Hatch comes complete with deck trim ring.



FREEMAN ROUND HATCH

34-240K.....15".....P.O.R
 Compression seal with an aluminum ring.
 Clear opening - 15"
 Deck Cutout - 17.88"
 OD Flange - 21.6"

34-241K.....18".....P.O.R
 Compression seal with an aluminum ring.
 Clear opening - 18"
 Deck Cutout - 21.24"
 OD Flange - 24.5"

34-242K.....20".....P.O.R
 Compression seal with an aluminum ring.
 Clear opening - 20"
 Deck Cutout - 22.66"
 OD Flange - 26.53"

34-243K.....24".....P.O.R
 Compression seal with an aluminum ring.
 Clear opening - 23.75"
 Deck Cutout - 27.12"
 OD Flange - 30.75"



FREEMAN SQUARE HATCH

34-252K20" x 20"P.O.R
 Lift out, knife edge seal with a steel ring.
 Clear opening - 20.14" x 20.14"
 Cutout - 23.07" x 23.07"
 OD Flange - 26.5" x 26.5"

34-253K24" x 24"P.O.R
 Lift out, knife edge seal with a steel ring.
 Clear opening - 24.6" x 24.6"
 Cutout - 27.96" x 27.96"
 OD Flange - 31.2" x 31.2"

34-254K30" x 30"P.O.R
 Lift out, knife edge seal with a steel ring.
 Clear opening - 30.1" x 30.1"
 Cutout - 33.1" x 33.1"
 OD Flange - 36.7" x 36.7"



FREEMAN OVAL 15 X 24 (LIFE OUT) HATCH

34-246K15" x 24"P.O.R
Aluminum cover, Aluminum ring.
 Clear opening - 14.79" x 23.73"
 Cutout - 18" x 27"
 OD Flange - 21.3" x 30"

34-260K15" x 24"P.O.R
Aluminum cover, Steel ring.
 Clear opening - 15.3" x 24.2"
 Cutout - 18" x 27"
 OD Flange - 21.3" x 30"



FREEMAN OVAL 15 X 24 (HINGED) HATCH

34-247K15" x 24"P.O.R
 Compression seal with an aluminum ring.
 Clear opening - 15" x 24"
 OD Flange - 23.4" x 30.6"



COMMERCIAL DUTY DECK HATCHES

Strong cast aluminum hatch with heavy tinted insert and reinforcing bars. S.S. adjuster and 2 tie down dogs.

Commercial Fishers' Choice!

Model 139 MEDIUM

Hole Cut-Out : 19 7/16" x 19 7/16"

O.D. Flange : 22 3/8" x 22 3/8"

Cut Out Radius : 3/4"

O.D. Radius : 2 1/4"

34-007K.....2695.00

Model 139 LARGE

Hole Cut-Out : 24" x 24"

O.D. Flange : 27 1/8" x 27 1/8"

Cut Out Radius : 1 1/16"

O.D. Radius : 2 9/16"

34-008K.....2995.00

Model 139 Gasket Material

Fits all 139 series hatches.

34-090K 13.95/Ft.



HATCH ADJUSTER

Chrome plated brass.

46-059R.....Adjusts from 10" to 17" 32.95

46-069R.....Adjust from 12 3/4" to 20 3/8" 58.95



FLUSH LIFTING HANDLES

Chrome plated zinc. Perko Product – so you know it's good! Countersunk for #8 screws.

46-436R.....3" x 2 1/4"30.70

As above, only stainless steel. Imported. Countersunk for #6 screws. Good quality.

46-731R.....3" x 2 1/4"23.95



NIBO DECK HATCHES

Bomar anodized heavy duty aluminum frame. Heavy tinted acrylic lens. Heavy hinge and adjusters. 2 Dogs. Superb finish. Used on many custom yachts.

Model 1070-10A

Hatch Opening:15-7/16" x 15-7/16"

Hole Cut-Out:16-1/2" x 16-1/2"

O.D. Deck Flange:18-3/16" x 18-3/16"

34-019K.....825.00

34-165K.....Inside Trim Ring89.95

34-168K.....Screen Kit94.95

Model 1039-10A

Hatch Opening:19-1/8" x 19-1/8"

Hole Cut-Out:20-1/4" x 20-1/4"

O.D. Deck Flange:21-7/8" x 21-7/8"

34-020K.....895.00

34-166K.....Inside Trim Ring109.95

34-169K.....Screen Kit109.95

Model 1049-10AX

Hatch Opening:24" x 24"

Hole Cut-Out:25-1/8" x 25-1/8"

O.D. Deck Flange:26-3/4" x 26-3/4"

34-021K.....1499.00

34-167K.....Inside Trim Ring169.95

34-170K.....Screen Kit129.95

NIBO GASKET MATERIAL

Fits hatches above.

34-089K13.95 /Ft.



STAINLESS STEEL DECK PLATE

High polished, stainless steel. Countersunk for #10 screws.

34-041R.....4" I.D.119.95



GRAY LEXAN DECK HATCHES

Our best selling hatch, now with improved mechanism and hardware. This hatch is manufactured by Bomar and carries the reputation for quality. Made of tough injection molded polycarbonate with stainless steel hardware, tinted lens allows light to enter, low profile, quick acting handles, replaceable gasket, totally waterproof. Color: Molded Black.

Model G-966 : Hole Cut-Out 16-7/8" x 16-7/8"

34-013K.....475.00

34-014K.....Inside Trim Ring54.95

Model G-995 : Hole Cut-Out 19-3/4" x 19-3/4"

34-016K.....675.00

34-017K.....Inside Trim Ring64.95

Gray Gasket material

Fits all Gray hatches above.

34-090K13.95 / Ft.



HEAVY DUTY BRONZE DECK PLATES

Machined finished. •Opening I.D. 6" •Hub O.D. 6 1/2"

•Length under flange 3/4" •Flange O.D. 8 1/8" • #12 screw size • Heavy Duty - Weight 5 lbs.

34-120M6" Model399.00

Machined finished. •Opening I.D. 4" •Hub O.D. 4 3/8"

•Length under flange 5/8" •Flange O.D. 5 3/4" • #12 screw size • Heavy Duty - Weight 3 lbs.

34-110M.....4" Model258.00



BOMAR INSPECTION HATCHES

Features: Molded high impact polycarbonate UV stabilized, locking smooth action "T" handles, extra heavy duty construction, stainless steel hinge pins, flush mount, tapered edges, non-skid surface, and quality finish.

Ord. #	Opening	Cut Out Size	Flange O.D.	Handles & Color	Price
34-200M	7" x 11"	8 3/16" x 12 3/16"	10 1/4" x 14 1/4"	1 & White	109.00
34-201M	7" x 11"	8 3/16" x 12 3/16"	10 1/4" x 14 1/4"	1 & Black	109.00
34-204M	9 3/4" x 19 1/2"	12" x 21 1/16"	13 3/4" x 23 1/2"	2 & White	199.00
34-205M	9 3/4" x 19 1/2"	12" x 21 1/16"	13 3/4" x 23 1/2"	2 & Black	199.00
34-208M	14" x 16"	16 1/4" x 17 5/8"	18 1/8" x 20 3/16"	2 & White	169.00
34-209M	14" x 16"	16 1/4" x 17 5/8"	18 1/8" x 20 3/16"	2 & Black	169.00
34-212M	9 3/4" x 26 3/4"	11 3/8" x 28 3/8"	14" x 31"	2 & White	229.00
34-213M	9 3/4" x 26 3/4"	11 3/8" x 28 3/8"	14" x 31"	2 & Black	229.00



ABS HATCH

14.5" X 10.5" Hatch, Plastic with twist and lock handle.
 O.D. Flange = 14 3/4" x 10 7/8"
 Cut Out Size = 11 5/8" x 7 3/4"
 Clear Opening = 10 3/4" x 6 7/8"
 Requires 10 pieces #10 screws or 10/32 M bolts
 34-397R.....49.95



ABS DECK PLATES

TWIST & LOCK LID

Watertight with o-ring. Seal on lid. White

34-047R	4" I.D. - 5 3/4" O.D.	15.50
34-048R	6" I.D. - 8" O.D.	18.95
34-049R	8" I.D. - 9 7/8" O.D.	36.95



POLYCARBONATE DECK PLATES

UV Stabilized. O-ring sealed lid.

7 5/16" I.D. - 10 9/16" O.D. - 8 1/2" cut out	
34-215P	8" dia., white76.00
34-216P	8" dia., black.....76.00

9 1/4" I.D. - 12 1/2" O.D. - 10 1/2" cut out	
34-218P	10" dia., white89.00
34-219P	10" dia., black.....89.00



RING PULL

Hand cast brass, triple chrome plated. Often used on lighter hatches as a lift.
 46-086R.....2 1/2" x 1 7/8"12.95



ABS HATCH

15" X 15" Hatch, Plastic with twist to lock handles.
 O.D. Flange = 14 7/8" x 14 7/8"
 Cut Out Size = 11 5/8" x 11 5/8"
 Clear opening = 10 7/8" x 10 7/8"
 Requires 12 pieces #10 screws or 10/32 bolts
 34-398R.....64.95



STAINLESS STEEL CLAM SHELL VENTS

304 stainless steel construction.

- 34-220R6 3/16" L x 5 3/4" W x 2 3/8" H19.95
- 34-221R7 5/8" L x 6 7/8" W x 2 13/16" H.....26.95



PERKO

Model 870 CHR

Model 1312 CHR

COWL VENTS

Model 870 CHR

Flanged front with air intake for 3" hose. Heavy chrome plated. 5" L x 4" H x 2 3/4" W.

- 34-062R62.60

Model 1312 CHR

Chrome plated with black plastic base. Uses 3" blower hose which threads into intake. 5 1/2" L x 4 1/2" W x 2 1/2" H.

- 34-063R51.45



SOLAR POWERED VENTILATORS

A simple way to ventilate your boat using the sunlight to operate the fan. Waterproof and totally safe. Cut out hole is 4 9/16". Outside flange is 8 1/2".

- 34-055RPlastic.....64.95
- 34-057RStainless Steel.....84.95



P.V.C. VENTS WITH COVER

- 34-050R3" Opening28.95
- 34-051R4" Opening34.95



P.V.C. VENTILATOR WITH COVER

Low profile.

- 34-052R4" Opening29.95



STAINLESS STEEL LOUVERED VENTS

Used for ventilation of engine compartments or wherever ventilation is required. Inset = 1". Screw size is #6.

3 Louvered Vent

Outside flange 4 5/16" x 8".

Cutout 3 3/8" x 7 3/8"

- 34-067R14.95

5 Louvered Vent

Outside flange 4 5/16" x 12 5/8".

Cut out 3 3/8" x 12".

- 34-068R19.95



STAINLESS STEEL VENTILATOR

No more dampness, mildew or condensation. Provides good air circulation. A closable lid can be activated from inside the boat if weather conditions require. 8" dia. stainless steel dome with 3" deck opening.

- 34-056R59.95



STAINLESS STEEL ROUND LOUVERED VENT 5"

Stainless Steel

- 34-069R5"4.95



STAINLESS STEEL LOUVERED VENTS

- 34-064RApprox. 4 1/2" x 5"5.45
- 34-065RApprox. 5" x 9"8.95
- 34-066RApprox. 6" x 10"13.95



MUSHROOM VENT

6" flange.

- 34-054R4" Opening14.95



STAINLESS STEEL BUTTERFLY VENT 5"

Open or closed option vent. Stainless Steel

- 34-070R5"8.95



Very Important
 For proper operation and cooling, the ventilation instructions for these refrigerators must be followed. Please read your owner's manual before installing your new refrigerator.

AC / DC / PROPANE (3-WAY)

Improved - replaces the N500. Largest capacity - 5.5 cubic feet - in its class. Adjustable thermostat so user can adjust to own preference. Automatic re-ignite on gas if flame goes out. Superior cooling performance. Convenient, eye-level controls. Easy-to-clean, no-tarnish white powder-coated shelves. Adjustable, removable door bins. One-gallon container shelf storage, and 2-liter and 1/2 gallon door bin storage. Made in America. 3-year warranty! Draws 14.2 amps. Shipping weight: 109lbs.

Approximate Freezer Compartment Size: 17" W x 6"H x 13"D

Cut out size : 42-5/8"H x 23-11/16"W x 24"D

72-001K.....5.5 cu. ft. (N512.3)..... 1995.00



HOT WATER HEATERS

Heat your water by running your engine's cooling water through the built in heat exchanger. Also has 120 VAC x 1500 Watt electric heater for dockside use. Constructed of aluminum tanks and insulated stainless steel housings. Unique to Force 10 is the addition of a temperature control valve (TCV Optional). It controls coolant flow through the heat exchanger, preventing excessively high water temperature and reducing the risk of scalding. Complete with ignition protected controls and pressure relief valve. For convenience, all connections are located on the same side of the units. "GALVANIC ISOLATOR" is highly recommended.

Galvanic corrosion is not covered under warranty. UL marine approved.

36-300K.....6gals (15.6"x19.5"x13.6"H) **Model 11810**..... 575.00
 36-302K.....11gals (18.75"x21.5"x16"H) **Model 11840**..... 725.00
 36-304K.....20gals (18.75"x18.75"x29.5"H) **Model 11870**..... 1095.00





DICKINSON PROPANE SEA•B•QUE

These barbeques are excellent in design and application. Manufactured from high-grade 20 gauge 304 stainless steel in an octagonal shape. Handles attached to the rollaway top allow for effortless opening and closing even when the the barbeque is hot. The design prevents flame-out in the windiest of conditions.

Small Sea•B•Que

Sturdy, neat and compact. The ideal small stainless steel barbeque for two people.

Dimensions: 24.2" W x 10"D x 12.4" H.

- 36-217M495.00
- 36-251PBBQ Cover (Black).....52.00

Large Sea•B•Que

One of the largest and most robust stainless boat barbeques on the market. Cooking barbequed food for you and your friends has never been more satisfying.

Dimensions: 28" W x 12.25"D x 14.5" H.

- 36-218M595.00
- 36-252PBBQ Cover (Black).....54.00

DICKINSON SPITFIRE 180 BARBEQUE

- Mirror finish 304 marine grade stainless lid.
- Brushed finish 304 marine grade stainless body.
- Sturdy construction for maximum strength.
- Features a 10,000 BTU burner.
- High strength octagonal design.
- Thermally insulated silicon side handles.
- Roll away hood with front handle.
- Will not flame out in high winds.
- CSA approved/ ABYC approved.

The Spitfire180 Barbeque comes with deck legs, drip tray, 2 removable stainless grill sections, a spark igniter for easy lighting, a thermometer and stainless latch to keep the hood closed while storing. Black vinyl all weather cover included.

Dimensions: 24" W x 14.75"D x 13" H.

- 36-219M635.00



S.S. FOOD TRAY & CUTTING BOARD

- 36-221PSm BBQ59.95
- 36-222PLg BBQ65.95



BBQ SCOTTY "POST AND SOCKET" TYPE MOUNT

This kit attaches to a Scotty type fishing rod holder or instrument mount socket. It fits all BBQ models and features the quick release snap latch kit for easy removal or replacement of your BBQ. The universal angle knuckle allows positioning at any angle.

- 36-209P132.00



PEDESTAL MOUNT

The Dickinson pedestal mount is the perfect way for you to mount your Sea-B-Que in locations such as a deck, or patio, boat, swim platform or pontoon boat. Features the quick release latch for easy removal and storage of your Barbeque. BBQ NOT INCLUDED.

- 36-224P176.00

VERTICAL/HORIZONTAL RAIL MOUNT KIT

Strong and sturdy mount for any Dickinson BBQ. Use with square or round rail 7/8" to 1 1/4" thick. Use on vertical, horizontal or some angled portions of rail

- 36-214P106.00



BBQ FISHING ROD HOLDER MOUNT

A versatile mounting kit for your BBQ. Crafted from the most durable materials, the fishing rod holder mount kit adapts to most fishing rod holders and has a universal level joint and a quick release snap latch for easy use.

- 36-213P132.00

BBQ TAFF RAIL MOUNT

The Taff Rail Mount Kit uses high quality stainless steel tubes and sockets to create a stand off mount for your BBQ that can be installed in a cap rail or taff rail, and the rails slide out and fold for easy storage

- 36-212P116.00



STRAIGHT-THRU FITTING

For LPG hose (1/4" & 1/8" ID) Copper Tube (1/4" to 3/8" ID). Nylon and rubber sealing gland. Liquid and vapor tight. Fits over and seals around 1/4" to 3/8" LPG copper tubing (before flare nuts attached) through bulkheads and decks up to 1/2" thick.

- 36-238K29.95



KUMMA STOW-N-GO BBQ

Designed for high pressure, disposable 1 lb. propane canisters or larger refillable tanks with hose attachment. Canisters, tanks and hoses sold separately.

Small BBQ (Model 125)

Weight: 14.5 lbs.

Cooking Surface Area: 125 square inches.

Dimensions: 20" W x 11.25"D x 11" H.

36-315P389.00



Medium BBQ (Model 160)

Weight: 16 lbs.

Cooking Surface Area: 160 square inches.

Dimensions: 23.25" W x 11.25"D x 11" H.

36-316P405.00



LARGE KUUMA STOW N GO 216 ELITE GRILL

Connections: Connects to 1 lb. disposable propane bottle. Easy to Transport: Grill features latch and handle for convenient portability. Features built-in thermometer, push button igniter, removable lift-and-clean liner, grease tray, latching lid and stay cool handle and fold away legs for easy grilling on any flat surface. Constructed of durable 304 stainless-steel and comes fully assembled. Cooking Surface Space: 216 square inches of cooking surface (including a top warming rack); Heat Output: 13,000 BTU/HR; Weight: Weighs approximately 21 lb.

36-317P579.00



KUUMA STOW N GO FOOD TRAY

Provides a convenient place to put your food while grilling. Comes with utensil hooks.

36-318PFor Model 12589.95

36-319PFor Model 160 & 216134.95



KUMMA RAIL MOUNT

Designed to mount your Kuuma Grill to your boat's railing. Can be used on 7/8"-1 1/4" round or square horizontal rail. This mount allows your grill to hang outside the rail to protect fiberglass from spills and splatters. Made of anodized aluminum with stainless steel hardware.

36-324P79.95



KUUMA BBQ COVERS

Helps protect Kuuma Grills from outdoor elements. Great for storing or covering your grill when not in use. Zipping closure for a secure fit. Works on mounted grill or as a tote. Made of durable, UV-resistant fabric.

36-320PFor Model 125 & 16071.95

36-321PFor Model 21692.95



KUUMA RV HOLDER MOUNT

Easily mount your grill to your RV's mounting rail. Fits all Kuuma brand grills. Made of durable stainless steel and aluminum. Mount is anodized black for a lasting finish. Thumbscrews for easy mounting and stability.

36-326P124.95



KUMMA ROD HOLDER MOUNT

Kuuma's rod holder mount enables you to turn any fishing rod holder into a grill mount. The rod holder mount has a 60 degree angle and an adjustable height. Fits into most rod holders with cross pins.

36-325P77.95



The name is
your assurance
of quality
workmanship
& reliability

Dickinson stainless steel stoves and heaters offer quality and dependability. The cookstoves feature cast iron tops, stainless steel construction, sea rails, and fast efficient oven heat. Both the cookstoves and stainless steel heaters are supplied with a 12 Volt blower and speed control. For 24 Volt or 32 Volt you must add a resistor, or damage will occur.



BERING (DIESEL COOKSTOVE)

Economical model. Overall size is 24"W x 15"D x 20"H. Heat output of 6500 BTU - 16250 BTU. Oven size 10.5"W x 13"D x 10.5"H. Weighs 80 lbs. Flue Size 5".

36-254P2695.00



PACIFIC (DIESEL COOKSTOVE)

Mid-size model. Overall size 22"W x 18"D x 20"H. Heat output of 6500 BTU - 16250 BTU. Oven size 10.5"W x 13"D x 10.5"H. Weighs 110lbs. Flue size 5".

36-255P3250.00



ADRIATIC (DIESEL COOKSTOVE)

For Medium size boats. Overall size is 26"W x 18"D x 20"H. Heat output of 6500 BTU - 16250 BTU. Oven size 15"W x 13"D x 10.5"H. Weighs 125 lbs. Flue size 5".

36-256P3650.00

Propane BBQ Accessories



Propane Hose with Standard Connector

36-245P6ft62.00
36-246P8ft68.00

Propane Hose "T" Type

36-248P8ft89.00

Accessory "T" Connector

Enables on board propane system to be used without disconnecting other appliances.

36-092P 69.95

Dickinson Gas Control with Regulator

36-244P69.95



ATLANTIC (DIESEL COOKSTOVE)

For larger boats. Overall size is 30"W x 20"D x 25"H. Heat output of 8125 BTU - 24375 BTU. Oven size is 16"W x 14.5"D x 12"H. Weighs 160lbs. Flue size 5".

36-257P4895.00



MEDITERRANEAN 3 BURNER PROPANE STOVE

This stove/oven features 2 efficient 7,000 BTU burners, and one larger 11,000 BTU burner, all equipped with safety 'flame-out' protection. 100% stainless steel. Thermostatically controlled oven complete with broiler. 7000 BTU oven burner and 4500 BTU over broiler. Pot holders. Removable cutting board.

Overall dimensions: 20 3/8" W x 20 1/4" D x 21 3/4" H. Cut out dimensions: 22" W x 20" D x 23 3/4" H.

36-204K.....Model 00-MED3B2950.00

Gimbal Installation Kit

36-205K.....49.95



3 BURNER SUBURBAN PROPANE STOVE

22" Suburban gas range offers high efficiency, well insulated oven with an especially large broiler. Door is black textured steel. Piezo ignitor. 9000 BTU/h front burner with linear valve. 2 6500 BTU rear burners.
Cut out size – 20 5/8"W x 21 3/4"H x 18 5/8"D
36-242K1095.00

dickinson



DICKINSON TWO BURNER PROPANE DROP-IN COOKTOP

The perfect galley solution for small boats or for all applications where space is at a premium. The dickinson Two Burner Drop-in Cooktop features heavy duty stainless steel construction with powerful 11,000 and 7,000 BTU burners. The unit is easily installed and comes with pot holders and a hardwood cutting board.
Cut out Dimensions: 21 1/2" W x 12 1/2"D x 4 1/4" H.
36-220K995.00



DICKINSON NEWPORT PROPANE CABIN HEATER

The Newport propane heater is beautifully crafted in stainless steel and is an attractive and functional addition to any boat interior. Boaters enjoy the comfort of dry heat and the ambiance of a warm cozy fireplace. Large ceramic glass flame-viewing window with high radiant efficiency. Easy to install – easy to use. Two models to choose from.

Kit includes: Blower fan to enhance hot air circulation. Stainless steel wall mounting plate. Exclusive Dickinson stainless steel, flexible direct-vent pipe 2.5" x 28". Exclusive Dickinson stainless steel direct-vent through deck fitting & flue cap.

Model P9000

Dimensions: 8 1/2" W x 5 1/2"D x 14" H.
Fuel Consumption: Low: 1 lb - 7 hours, 20lb -140 hours
High: 1 lb - 5 hours, 20lb -100 hours
Heat Rating: Low: 5,500 BTU High:7,500 BTU
36-048K1395.00

Model P12000

Dimensions: 10" W x 7 1/4"D x 16" H.
Fuel Consumption: Low: 1 lb - 5.5 hours, 20lb -110 hours
High: 1 lb - 3.9 hours, 20lb - 78 hours
Heat Rating: Low: 7,000 BTU, High:9,700 BTU
36-049K1950.00

NEW



NEWPORT (WOOD HEATER)

Designed for casual use ideal for boats 20-25ft. This heater burns one to two 1" thick wood or presto log, a handful of charcoal briquettes or coal. Removable ash drawer and damper control.
Overall size is 7.88"W x 10"D x 14.7"H.
Heat output of 3000 BTU - 8000 BTU.
Weighs 15lbs. Flue size 3".
36-285K675.00

dickinson



NEWPORT (DIESEL HEATER)

Bulkhead mounted heater. Overall size is 9"W x 10"D x 19"H. Heat output of 6500 BTU - 16250 BTU.
Weighs 20lbs. Flue size 3".
36-278K1360.00

dickinson



ALASKA (DIESEL HEATER)

Free standing heater. Overall size 9"W x 10"D x 20"H.
Heat output of 6500 BTU - 16250 BTU. Weighs 20lbs.
Flue size 3".
36-230K1299.00

dickinson

NEW



ANTARCTIC DIESEL HEATER

Floor mounted. Requires 3" diameter chimney parts.
Overall size is 13"W x 14"D x 25"H. Weighs 27 lbs.
Heat Output:Low: 6500 BTU - High: 16250 BTU
36-279K 1495.00



METHYL HYDRATE

Guaranteed pure; use for thinning shellac. Excellent fuel for alcohol stoves. Smokeless when burned.
52-014MLitre9.49
52-015M 4 Litre17.49



COOKSTOVE ACCESSORIES (5" PIPE AND FLU)

36-040P5" x 22" S.S. Stove Pipe.....	75.00
36-100P5" S.S. Thru-Deck C/W Dress Ring.....	195.00
36-041P5" x 45° S.S. Elbow	82.00
36-133P5" Barometric Damper	142.00
36-035P5" Stainless Steel "DP" Cap	210.00
36-141P5" Stainless Steel H-Cap	211.00

HEATER ACCESSORIES (3" PIPE AND FLU)

36-015P3" x 22" S.S. Pipe	52.00
36-073P3" S.S. Thru-Deck C/W Dress Ring.....	139.00
36-042P3" x 45° S.S. Elbows	68.00
36-132P3" Barometric Damper	113.00
36-074P3" x 18" S.S. Pipe Guard	108.00
36-014P3" Stainless Steel "DP" Cap	158.00
36-142P3" Stainless Steel H-Cap	158.00



DICKINSON REPLACEMENT STOVE PARTS

36-004P12v Blower Motor C/W Fan	139.95
36-020PSuper Heater for 6" Pot	53.00
36-023PDiesel oil Carburetor (Atlantic)	315.00
36-009PDiesel oil Carburetor (Bering, Pacific, Adriatic)	315.00
36-008PDiesel oil Carburetor (Alaska, Newport).....	315.00
36-011PRep. Cast Iron Top (Bering)	679.00
36-005PRep. Cast Iron Top (Pacific)	745.00
36-019P6 3/4" x 10" Stove Lid	119.00
36-057P5" Flue Collar (Inside Tabs)	42.00
36-051P6" Burner Pot for Bering	269.00
36-139P6" Burner Pot for Pacific/Adriatic	275.00
36-052P6" Burner Ring	30.00
36-054P7" Burner Ring Set.....	158.00
36-060PFire Brick 4" x 8" x 1"	24.00
36-058P5lb. Bag Furnace Cement	54.00
36-059PMICA Window For Bering	30.00



BLOWER SPEED CONTROL

Supplied on all new Dickinson stoves and heaters. Separate on/off switch with a variable potentiometer for more control of blower speed. Parts can easily be removed from enclosure for replacement on older stove models.

36-001P12V.....	79.95
36-002P24V.....	79.95
36-003P32V.....	79.95



FUEL PUMP

Adjustable pressure pump with built in regulator makes it ideal for internally vented systems. Prevents excessive fuel pressure build up from occurring at carburetor. Reduces chances of vapor lock. For non fuel-injection applications. An ideal pump for oil stoves when a gravity fed system is not possible or preferred. Adjustable from 1.75 to 5 psi. Factory set at 2.5 psi.

36-006P	355.00
---------	-------	--------





2 VENT CABIN HEATER KIT 9"

•28000 BTU output • Kit includes 2 adjustable louvers, mounting brackets, stainless steel mounting hardware, 3 speed switch and plate, 9' wiring harness, 25' of 3" vent hose. •Requires 5/8 water hose. •Built in cooling duct to direct cool air across the motor to extend motor life.

•Amp Draw @12V , 4.9/6.6/9.6

Dimensions 9.5"W x 6.5"H x 9"D

36-330P	12V	589.00
36-331P	24V	625.00



3 VENT CABIN HEATER KIT 16"

•40000 BTU output • Kit includes 3 adjustable louvers, mounting brackets, stainless steel mounting hardware, 3 speed switch and plate, 9' wiring harness, 37' of 3" vent hose. •Requires 5/8 water hose.

•Amp Draw @12V , 5.7/7.1/11.6

Dimensions 15.9"W x 7"H x 9.6"D

36-333P	12V	625.00
36-334P	24V	649.00



4 VENT CABIN HEATER KIT 16"

•40000 BTU output • Kit includes 4 adjustable louvers, mounting brackets, stainless steel mounting hardware, 3 speed switch and plate, 9' wiring harness, 50' of 3" vent hose. •Requires 5/8 water hose.

•Amp Draw @12V , 5.5/7.1/11.6

Dimensions 15.9"W x 7"H x 9.6"D

36-336P	12V	629.00
36-337P	24V	655.00



9" GRILL CABIN HEATER KIT

•28000 BTU output • Heater mounts using grill front panel, 3 speed switch and plate, 9' wiring harness • Built in cooling duct to direct cool air across the motor to extend motor life •Requires 5/8 water hose.

•Amp Draw @12V , 4.9/6.6/9.6

Dimensions 9.5"W x 6.5"H x 9"D

36-342P	12V	409.00
36-343P	24V	425.00



16" GRILL CABIN HEATER KIT

•40000 BTU output • Heater mounts using grill front panel, 3 speed switch and plate, 9' wiring harness •Requires 5/8 water hose.

•Amp Draw @12V , 5.5/7.1/11.6

Dimensions 15.9"W x 7"H x 9.6"D

36-345P	12V	469.00
36-346P	24V	489.00



REPLACEMENT PARTS

36-356P	12V Single Blower Motor	185.00
36-357P	24V Single Blower Motor	195.00
36-358P	12V Double Blower Motor	199.00
36-359P	24V Double Blower Motor	199.00
36-362P	4 Position Switch with Knob	24.95
36-363P	3" Dome Style Louvered Vent	25.95
36-366P	Maradyne Repl. Core 2 Outlet	159.00
36-367P	Maradyne Repl. Core 3 & 4 Outlet ...	189.00



RADEX CABIN HEATERS

Heat your cabin by using your engine's hot water. Stainless steel construction, 12V fan, 3/4" hose connections.

Radex I

10" W x 7" H x 5" D. (One - 100 CFM fan).

36-045K	12,000 BTU	359.00
---------------	------------------	--------

Radex II

17" W x 7" H x 5" D. (Two - 100 CFM fans).

36-046K	24,000 BTU	499.00
---------------	------------------	--------

Radex Motor & Fan

36-144P	12V (100 CFM)	69.95
---------------	---------------------	-------

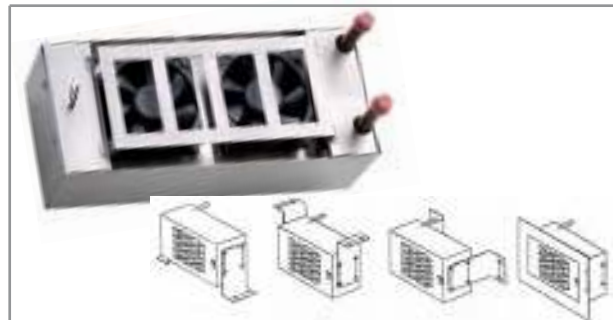

RADEX MOUNTING BRACKETS

Bulkhead Flush Mount

36-095P	For Radex 1	54.00
36-096P	For Radex 11	63.00
Floor, Ceiling or Regular Bulkhead Mount for Radex I or II		
36-094P		47.00



SOLAR-RAY SEARCHLIGHTS - 10" & 12"

PERKO "Solar-Ray" searchlights have served seafarers world wide for years. Features include: Heavy gauge brass and cast bronze construction. "Perko-Kote" white finish for added protection. Parabolic mirror reflectors. Good heat dissipation with Perko quality construction.

Supplied without socket or bulb - See below for components to suit your requirements.

10" SOLAR-RAY SEARCHLIGHTS

30-500K"J" Length - 20 1/8""E" Length - 8 1/2"2498.35
30-501K"J" Length - 28 1/4""E" Length - 8 1/2"2780.80
30-502K"J" Length - 44 3/4""E" Length - 8 1/2"3153.15
30-503K"J" Length - 20 1/8""E" Length - 15 1/2"2605.30
30-504K"J" Length - 28 1/4""E" Length - 15 1/2"2887.80
30-505K"J" Length - 44 3/4""E" Length - 15 1/2"3311.60

SOCKETS FOR 10" SOLAR-RAY SEARCHLIGHTS

30-506K12V - 2 Pin (875-001)368.60
30-507K24V - 2 Pin (876-001)368.60
30-508K32V - 2 Pin (878-001)368.60
30-510K120V - 2 Pin (879-001)368.60

SOLAR-RAY BULB DATA FOR 10" SEARCHLIGHTS

Ord. No.	Bulb Type	Candle Power	Beam:Hor./Vert.	Price
30-511K12V - 2 Pin(1,168,000 CP)1.7 ⁰ / 1.4 ⁰86.35
30-512K24V - 2 Pin(891,000 CP)2.6 ⁰ / 1.5 ⁰64.35
30-513K32V - 2 Pin(571,000 CP)2.6 ⁰ / 1.7 ⁰59.95
30-515K120V - 2 Pin(908,000 CP)4.3 ⁰ / 1.9 ⁰62.60

SOLAR-RAY REPLACEMENT PARTS

30-516KReflector for 10" Lt. (890-001)718.90
---------	--------------------------------------	-------------

12" SOLAR-RAY SEARCHLIGHTS

30-521K"J" Length - 22 1/8""E" Length - 8 1/2"3200.15
30-522K"J" Length - 30 1/4""E" Length - 8 1/2"3482.50
30-523K"J" Length - 46 3/4""E" Length - 8 1/2"3841.95
30-524K"J" Length - 22 1/8""E" Length - 15 1/2"3307.10
30-525K"J" Length - 30 1/4""E" Length - 15 1/2"3589.55
30-526K"J" Length - 46 3/4""E" Length - 15 1/2"4000.35

SOCKETS FOR 12" SOLAR-RAY SEARCHLIGHTS

30-527K12V - 2 Pin (875-002)368.60
30-528K24V - 2 Pin (876-002)368.60
30-529K32V - 2 Pin (878-002)368.60
30-531K120V - 2 Pin (879-002)368.60

SOLAR-RAY BULB DATA FOR 12" SEARCHLIGHTS

Ord. No.	Bulb Type	Candle Power	Beam:Hor./Vert.	Price
30-511K12V - 2 Pin(1,617,000 CP)1.5 ⁰ / 1.2 ⁰²86.35
30-512K24V - 2 Pin(1,349,000 CP)2.2 ⁰ / 1.5 ⁰64.35
30-513K32V - 2 Pin(865,000 CP)2.4 ⁰ / 1.6 ⁰59.95
30-515K120V - 2 Pin(1,410,000 CP)4.3 ⁰ / 1.9 ⁰62.60

SOLAR-RAY REPLACEMENT PARTS

30-532KReflector for 12" Lt. (890-002)765.50
---------	--------------------------------------	-------------

INFORMATION GUIDE Lights with lever control assembly, E-length of 8 1/2" are for maximum ceiling thickness of 4 1/2". If ceiling thickness exceeds 4 1/2" you will require "E" length assembly of 15 1/2".



19" SOLAR-RAY SEARCHLIGHTS

All Aluminum - White Perko*Kote Finish - 32, 120 or 230 Volts

The 1900 Series - Solar-Ray Searchlights are designed and built with the commercial users in mind, where maximum size and brilliance count. These units are constructed of marine aluminum with heavy duty castings and heavy gauge reinforced bodies for extra durability. They are finished in our white PERKO*KOTE finish; an advanced process that eliminates the need for painting while providing a scratch resistant and chip-proof surface for painting when necessary to match the color of the vessel.

Available with Lever/Gear or Distant Electric Remote Controls. All models feature halo deflectors, parabolic glass mirror reflectors for maximum light output and ventilation covers for quick dissipation of heat to help prolong bulb life. Hinged front doors have quick release stainless steel latches to provide easy access for bulb replacement.

Supplied without socket or bulb - See below for components to suit your requirements.

19" SOLAR-RAY SEARCHLIGHTS

30-343K.....Lever/Gear Control (Model 1902).....P.O.R.

30-344K.....Distant Electric Remote Control (Model 1901).....P.O.R.

30-467K.....Electric Remote Control (Model 1902DE4).....P.O.R.

SOCKETS FOR 19" SOLAR-RAY LIGHTS

30-346K.....120V, Mogul Prefocus.....P.O.R.

BULBS FOR 19" SOLAR-RAY LIGHTS

120V Mogul Pre Focus

1500Watt, Beam:Hor./Vert. - 5.9° /5.7°

30-328K.....5,596,000 Candle Power.....P.O.R.

SOLAR-RAY REPLACEMENT PARTS

30-361K.....Reflector for 19" light (890-004).....P.O.R.

www.mercersmarine.com



- Always Open
- Sale & Feature items
- View Catalogue



- Thousands of products
- Updated Regularly
- Up to date Pricing



- Mobile Friendly
- Shop from anywhere at anytime

Also find us on





PRECISION "WIRELESS" CONTROLLED SPOTLIGHT

The innovative Marinco Precision Wireless Controlled Light addresses the most common issues found in marine-grade spotlights. In doing so it has become the most versatile, durable, consistent and easy-to-use spotlight on the market. Its unique, totally enclosed housing design protects all critical components from moisture, salt, shock and vibration for long-lasting operation. Easy snap-in mount system. Whether mounted upright or suspended upside down, you get 370 deg sweep rotation and 120 deg tilt (75 deg up, 45 deg down) in a durable IP56 weatherproof housing. Inside, a brilliant 100 Watt H3 Halogen lamp with an optimized parabolic reflector pierces the ultra clear lens to provide a consistent light pattern. **Universal 12 & 24 Volt circuit (shipped with 12 Volt bulb installed / 24 Volt bulb included).**

- 30-560M.....White 675.00
- 30-561MBlack..... 675.00
- Replacement Bulbs**
- 30-565P12V.....10.95
- 30-566P24V.....11.95



BRIDGE MOUNTED HARDWIRED REMOTE

Optional for searchlight above. For 12 or 24V.
30-567P.....77.90



HANDHELD WIRELESS REMOTE

Optional for searchlight above. For 12 or 24V. Range approx. 200 ft. Floats. Glow in the dark remote buttons. Battery included
30-568P.....126.95



MARINE HALOGEN SPOTLIGHT

1400 Lumens. 450 Meters Long Range Beam Distance. Direct use with 12V DC plug adapter. Heavy gauge coiled cord extends up to 10 ft. (3M). Aluminum Reflector with tempered glass colored lens. On/Off sliding switch. Durable ABS plastic housing. Retractable metal hanging bracket. Contoured rubberized grip. High Intensity 100 Watt Halogen Bulb.

- 30-272M.....64.95



LED RECHARGEABLE MARINE SPOTLIGHT

Super bright CREE XM-L2 10 Watt LED. Powered by 152P rechargeable Li-ion battery (3.7V 4400mAh) – included. Dual recharge, either AC/DC charger or 12V DC car plug adapter – both included. Durable ABS Poly Carbonate housing with rubberized grip & bezel. Auto brightness reduction after 5 minutes. High/Low/Off. Adjustable foot stand. Charging indicator.

- 30-276M.....109.95



LED Model

LED ECONOMY CABIN CONTROLLED SEARCHLIGHT

An economical searchlight for small boats. S.S. construction. Material: S.S. 304. White LED Beam (18pcs x 2W White LED). Size: 8"(H) above deck. Effective Lumen: 1100LM.

Voltage: 10-30VDC. 4 1/2" Diameter beam.
30-076R12V.....149.95





GOLIGHT SEARCHLIGHTS

UV Ray and saltwater resistant. Permanent Mount. 370° rotation x 135° tilt. 225,000 Candela, Max beam distance 3113 ft. 5.5 Amp at 13.8V. 8° Beam angle. 65 Watts. Comes with Mounting hardware and lens cover. Available with wireless remote or wired remote. See models below. Approximately 7" x 7" x 6.5"

Model 2000GT - Wireless handheld remote
 30-570P12V..... 499.00
 30-595PReplacment Bulb..... 34.95

Model 2020GT - Hardwired dash mount remote
 Comes with 20' wiring harness with quick disconnects for easy installation.
 30-574P12V..... 479.00
 30-595PReplacment Bulb.....34.95
 30-598P20' Extension Cable.....74.95



GOLIGHT STRYKER SEARCHLIGHT WITH WIRELESS REMOTE

Model 3000ST
 Permenent mount. 370° Rotation x 135° Tilt. 200,000 Candela, Max Beam Distance 2,933 ft. 5.5 amps. 10° Beam Angle. 65 watts. UV Ray and Saltwater Resistant. Weather Proof for Land and Sea Applications. Stainless Steel Mounting Plate.

Package includes:
 •Wireless handheld remote.
 •Rockguard Lens Cover
 •Stainless steel Mounting system
 Approximately 7" x 7" x 6.5"

30-580P12V..... 649.00
 30-596PReplacment Bulb.....39.95



GOLIGHT SEARCHLIGHT WITH WIRELESS DASH MOUNT & REMOTE

Model 2007GT
 Permenent or portable mounting options. 370° Rotation x 135° Tilt. 225,000 Candela, Max Beam Distance 3113 ft. 5.5 amps. 8° Beam Angle. 65 watts. UV Ray and Saltwater Resistant. Weather Proof for Land and Sea Applications. Stainless Steel Mounting brackets for permanent mount option.

Package includes:
 •Wireless handheld remote.
 •Wireless Dash Mount remote.
 •Rockguard Lens Cover
 •Stainless steel Mounting Bracket
 Approximately 7" x 7" x 8"

30-584P12V..... 625.00
 30-596PReplacment Bulb.....39.95



GOLIGHT STRYKER LED SEARCHLIGHT WITH WIRELESS REMOTE

Model 30004ST
 10 High Flux LED's. Permenent mount. 370° Rotation x 135° Tilt. 410,000 Candela, Max Beam Distance 4,100 ft. 2.8 amps at 13.8V. 8° Beam Angle. UV Ray and Saltwater Resistant. Weather Proof for Land and Sea Applications. Stainless Steel Mounting Plate.

Package includes:
 •Wireless handheld remote.
 •Stainless steel Mounting system
 Approximately 7" x 7" x 6.5"

30-590P12V..... 1139.00



GOLIGHT RADIORAY LED SEARCHLIGHT WITH WIRED REMOTE

Model 20204GT
 10 High Flux LEDs. Permenent or portable mounting options. 370° Rotation x 135° Tilt. 1 Piece, 10-LED. White light, clear lens. 8° beam angle. 544,000 Candela, Max Beam Distance 4839ft. 3.7 amps. UV ray and saltwater resistant. Weather proof for land and sea applications. Stainless Steel Mounting Plate. Comes with hardwired dash mount remote with 20' wiring harness.

Approximately 7" x 7" x 6.5"

30-591P12V..... 875.00



GOLIGHT RADIORAY LED SEARCHLIGHT WITH WIRELESS REMOTE

Model 20004GT
 10 High Flux LEDs. Permenent or portable mounting options. 370° Rotation x 135° Tilt. 1 Piece, 10-LED. White light, clear lens. 8° beam angle. 544,000 Candela, Max Beam Distance 4839ft. 3.7 amps. UV ray and saltwater resistant. Weather proof for land and sea applications. Stainless Steel Mounting Plate. Wireless remote will operate a light up to 80' away.
 Approximately 7" x 7" x 6.5"

30-593P12V..... 945.00



7" SEALED BEAMS

- 30-067P12v, 200,000 CP, 100W.....129.35
- 30-068P24v, 470,000 CP, 450W.....234.00
- 30-069P32v, 260,000 CP, 200W.....75.95



QUARTZ HALOGEN BULBS

4 5/8" Overall Length.

- 30-093P12V x 150W.....35.30
- 30-095P32V x 300W.....35.30
- 30-096P120V x 300W.....7.90
- 30-130P120V x 500W.....8.35

7 1/2" Overall Length

- 30-360P130V x 1000W.....23.05
- 30-358P240V x 1000W.....23.05

10" Overall Length

- 30-149P240V x 1000W.....24.45



L.E.D. DECK LIGHT

Material: Aluminum alloy, PC lens, S.S.304 bracket. LED Type: 6 x 1W cool white LED. LED Lifetime: 50000hrs. Beam Angle: 120°. Color Temperature: 5000~5650K. Effective Lumen: 680LM. Wattage: 8.4W. Voltage: 10-30VDC. Size: 6 1/16" x 1 1/2".

- 30-123R.....99.95



HELLA WORK LIGHT

This light features a Halogen bulb for extra light and longer life. Marine plastic case with S. S. hardware. This light swivels and tilts on its own base. Complete with 12V halogen bulb.

6 5/8"H x 3 3/4"W x 3" D.

- 30-086R.....52.45



L.E.D. WORKLIGHT

Die Casting Aluminum. PC Lens. Beam Angle: 40°. 12W. Voltage: 12 VDC. Waterproof IP67. Bracket Allows for Back & Forth Tilt Adjustment. Pre-Wired with 30cm Cable, UL1430, 18AWG

Size Approx. 4 3/4" W x 2 3/4"H

- 30-644R.....119.95



L.E.D. SPOT WORK LIGHT

LED Spot Light, 9-60 VDC. Wattage: 45W. Die cast aluminum housing, S.S.201 bracket. LED Type: 15 x 3W cool white LED. Color Temperature: 6000K. Effective Lumen: 3000LM. IP67 waterproof.

Size: 6.5" x 4.2" x 3.2"

- 30-653R.....57.95



L.E.D. WORKLIGHT

Die casting aluminum, acrylic lens, S.S. 304 bracket. LED Type: 6 x 3W "CREE" Cool white LED. LED Lifetime: 50000hrs. Beam Angle: 60°. Effective Lumen: 1260LM. Wattage: 18W. Voltage: 10-30 VDC

Size Approx. 4 1/4" x 3 7/8" x 2 7/8"

- 30-655R.....69.95



L.E.D. SPOTLIGHT

Material: Die Casting Aluminum. PC Vacuum- Coated Reflector. LED Type: 12 x 3W Cool White LED.

Lifetime: 50000hrs. Beam Angle: 40°.

Color Temperature: 5000-6500K. Wattage: 30W.

Effective Lumen: 710LM. Voltage: 9-56 VDC.

Waterproof IP66. Bracket Allows for Back & Forth Tilt Adjustment. Pre-Wired with 30cm Cable, UL1430, 18AWG

Size Approx. 6 1/2" Dia.

- 30-650R.....249.95



HIGH POWER L.E.D. WORKLIGHT

Made of Aluminum, With PC Outer Ring. Rating: Multi Voltage 9-56V DC/12W With 6x3W (5000-6500K) Lambertian. Pre Wired with 2M PU Cable. Bracket allows full tilt & 360 rotation adjustment. Operation temp: -20 to +60 degrees Celcius. IP66. Size Approx. 6" x 5 3/4"

- 30-649R.....84.95









Rhyno outdoor LED flood lights are mounted in a high quality aluminum alloy housing with corrosion resistive coating, complete with stainless steel bolts and screws. The lenses are tempered glass with a silicone rubber gasket. These lights replace the equivalent of up to 10 times the power of incandescent lights with energy savings of up to 90%. Approximate lifespan: 50000 Hours

100-277VAC Flood Lights

Mfg#	10 Watts RL10-120	15 Watts RL15-120	30 Watts RL30-120	50 Watts RL50-120	75 Watts RL75-120
					
Part #	30-820R	30-821R	30-823R	30-824R	30-825R
Input Volts	100-277VAC	100-277VAC	100-277VAC	100-277VAC	100-277VAC
Input Amps	0.08A at 120V	0.125A at 120V	0.25A at 120V	0.42A at 120V	0.63A at 120V
Lumens	1080	1300	3000	5200	8645
Beam Angle	120°	120°	120°	120°	120°
Rating	IP65	IP65	IP65	IP65	IP65
WxHxD	6" x 4" x 3.46"	5" x 3.5" x 1.45"	8.9" x 5" x 1.9"	8.9" x 5" x 1.9"	12" x 8.7" x 3"
Warranty	2 Year	2 Year	2 Year	2 Year	2 Year
Colour	Bronze	Bronze	Bronze	Bronze	Bronze
Price	\$89.00	\$117.00	\$160.00	\$245.00	\$365.00

12/24VDC Flood Lights

Mfg#	10 Watts RL10-12/24	15 Watts RL15-12/24	30 Watts RL30-12/24	50 Watts RL50-12/24	75 Watts RL75-12/24	95 Watts RL95-12/24
						
Part #	30-810R	30-811R	30-813R	30-814R	30-817R	30-818R
Input Volts	12/24VDC	12/24VDC	12/24VDC	12/24VDC	12/24VDC	12/24VDC
Input Amps	0.83A at 12V	1.25A at 12V	2.5A at 12V	4.2A at 12V	6.25A at 12V	7.9A at 12V
Lumens	1080	1300	3000	5000	8645	12312
Beam Angle	120°	120°	120°	120°	120°	120°
Rating	IP65	IP65	IP65	IP65	IP65	IP65
WxHxD	6" x 4" x 3.46"	5" x 3.5" x 1.45"	8.9" x 7.1" x 1.9"	8.9" x 7.1" x 1.9"	12" x 8.7" x 3"	12" x 8.7" x 3"
Warranty	2 Year	2 Year	2 Year	2 Year	2 Year	2 Year
Colour	Bronze	Bronze	Bronze	Bronze	Bronze	Bronze
Price	\$89.00	\$117.00	\$160.00	\$245.00	\$365.00	\$449.00

Rhyno outdoor LED flood lights are mounted in a high quality aluminum alloy housing with corrosion resistive coating, complete with stainless steel bolts and screws. The lenses are tempered glass with a silicone rubber gasket. These lights replace the equivalent of up to 10 times the power of incandescent lights with energy savings of up to 90%. Approximate lifespan: 50000 Hours



95 Watt (RL95-120-04)

Input Voltage:100-277Vac
 Input Amps: 0.79A at 120V
 Lumen Output: 12312 lm
 Beam Angle: 120°
 Bronze Construction
 Rating: IP65
 Dimensions: 12" W x 8.7"H x 3"D
 30-826R95 Watt..... 449.00

150 Watt (RL150-120-04)

Input Voltage:100-277Vac
 Input Amps: 1.25A at 120V
 Lumen Output: 18294 lm
 Beam Angle: 120°
 Bronze Construction
 Rating: IP65
 Dimensions: 16" W x 11.5"H x 4"D
 30-827R150 Watt..... 575.00

190 Watt (RL190-120-04)

Input Voltage:100-277Vac
 Input Amps: 1.58A at 120V
 Lumen Output: 23465 lm
 Beam Angle: 120°
 Bronze Construction
 Rating: IP65
 Dimensions: 16" W x 11.5"H x 4"D
 30-828R190 Watt..... 749.00



Replacement LED Tube

LED VAPOUR PROOF LIGHTS

These Rhyno LED Vapour proof lights have a clear lens and an off-white housing made of 100% UV stabilized Polycarbonate with a Silicon gasket all stainless steel hardware. They have a 3/4" waterproof nylon cable gland and can be surface mounted or suspended, perfect for machine rooms, workshops, galleys, stores, walk-in-coolers, passage ways, accommodations, public areas and more. They are designed for indoor and outdoor applications and meet marine requirements. Rated IP65, 2 year Warranty.

Two (2) tubes included with each fixture.

2' Long Lights

9-30 volt model (RL-MX486-2-10/30)

2100 lumens, beam angle is 120°, T8 self ballasted.
 Frosted tube lenses, 27" Long x 4" High x 7" wide.
 30-865P.....Complete Fixture (Tubes Included) .. 164.00
 30-874PReplacement LED Tube(ea.)..... 23.95

110-277 volt model (RL-MX486-2-120V)

2100 lumens, beam angle is 120°, T8 self ballasted.
 Frosted tube lenses, 27" Long x 4" High x 7" wide.
 30-868P.....Complete Fixture (Tubes Included) .. 164.00
 30-878PReplacement LED Tube(ea.) 23.95

4' Long Lights

9-30 volt model (RL-MX486-4-10/30)

3700 lumens, beam angle is 120°, T8 self ballasted.
 Frosted tube lenses, 49.75" Long x 4" High x 7"
 30-866P.....Complete Fixture (Tubes Included) .. 240.00
 30-875PReplacement LED Tube(ea.)..... 32.95

110-277 volt model (RL-MX486-4-120V)

3700 lumens, beam angle is 120°, T8 self ballasted.
 Frosted tube lenses, 49.75" Long x 4" High x 7" wide
 30-869P.....Complete Fixture (Tubes Included) .. 240.00
 30-879PReplacement LED Tube(ea.) 23.95



Rhyno outdoor LED work lights are mounted in a high quality aluminum alloy housing with corrosion resistive coating, complete with stainless steel bolts and screws. The lenses are tempered glass with high light transmission. They are designed for low heat loss, and are waterproof and dustproof with insulated silicon rubberized wire sheathing. Approximate lifespan: 30000 Hours

10-30VDC Work Lights

Mfg#	18 Watts RL-WL018W	18 Watts RL-WL018R	27 Watts RL-WL027	35 Watts RL-WL035
				
Part #	30-770R	30-771R	30-772R	30-773R
Input Volts	10-30VDC	10-30VDC	10-30VDC	10-30VDC
Input Amps	1.46A at 12V	1.5A at 12V	2.25A at 12V	3.0A at 12V
Lumens	1600	1600	2400	3000
Beam Angle	Flood	Flood	Flood	Flood
Rating	IP68	IP68	IP68	IP68
Rows	6 x Circular	1 x 6	9 x Circular	4 x 4
WxHxD	4.6" x 1.7"	6.3"x2.5"x2.5"	5.1"x4.4"x2.2"	5.2"x4.6"x2.6"
Warranty	1 Year	1 Year	1 Year	1 Year
Colour	Black	Black	Black	Black
Price	\$31.50	\$31.50	\$42.50	\$56.50

Mfg#	60 Watts RL-WL060	16 Watts RL-WLC016	50 Watts RL-WLC050	90 Watts RL-WLC090
				
Part #	30-775R	30-780R	30-782R	30-783R
Input Volts	10-30VDC	10-30VDC	10-30VDC	10-30VDC
Input Amps	5.0A at 12V	1.4A at 12V	4.2A at 12V	7.5A at 12V
Lumens	5200	1400	4300	8100
Beam Angle	Flood	Flood	Flood	Flood
Rating	IP68	IP68	IP68	IP68
Rows	2 x 3	2 x 2	5 x Offset	3 x 3
WxHxD	6.2" x 5.5"x5.2"	3.2"x3.0"x3.3"	5.7"x5.8"x3.1"	6.3"x5.5"x5.2"
Warranty	1 Year	1 Year	1 Year	1 Year
Colour	Black	Black	Black	Black
Price	\$208.00	\$72.00	\$159.00	\$238.00



30-836K110/227V x 300W1050.00

LED HIGH POWER SPOT LIGHTS

LED HIGH POWER 12.5" 300W SPOT LIGHT

This High-Power Spot Light module mounts where the light is needed and the driver module mounts safely away out of reach from harsh environments. The spot light module is made of 1070 pure aluminum and the mounting bracket is Stainless Steel. With the appropriate electrical components, the spot light and drive modules can be mounted up to 50 feet away from each other.

Specifications:

- Watts: 300
- Input Volts: 110 – 277 VAC
- Input Amps: 2.5A @ 120 VAC
- Lumens: 41,191 @ 5000K
- Beam Angle: 30°
- Color: Black
- Rating: IP66
- Face Area: 12.5"
- Certification: UL, CUL
- Light shade included.



30-841K110/227V x 500W1560.00

LED HIGH POWER 14" 500W SPOT LIGHT

This High-Power Spot Light module mounts where the light is needed and the driver module mounts safely away out of reach from harsh environments. The spot light module is made of 1070 pure aluminum and the mounting bracket is Stainless Steel. With the appropriate electrical components, the spot light and drive modules can be mounted up to 50 feet away from each other.

Specifications:

- Watts: 500
- Input Volts: 110 – 277 VAC
- Input Amps: 4.17 @ 120 VAC
- Lumens: 87,129 @ 5000K
- Beam Angle: 30°
- Color: Black
- Rating: IP66
- Face Area: 14"
- Certification: UL, CUL
- Light shade included.



30-851K110/227V x 750W2250.00

LED HIGH POWER 22" 750W SPOT LIGHT

This High-Power Spot Light module mounts where the light is needed and the driver module mounts safely away out of reach from harsh environments. The spot light module is made of 1070 pure aluminum and the mounting bracket is Stainless Steel. With the appropriate electrical components, the spot light and drive modules can be mounted up to 50 feet away from each other.

Specifications:

- Watts: 750
- Input Volts: 110 – 277 VAC
- Input Amps: 6.25 @ 120 VAC
- Lumens: 110,827 @ 5000K
- Beam Angle: 35°
- Color: Black
- Rating: IP66
- Face Area: 22.5"
- Certification: UL, CUL
- Light shade included.



30-855K110/227V x 1000W3050.00

LED HIGH POWER 22" 1000W SPOT LIGHT

This High-Power Spot Light module mounts where the light is needed and the driver module mounts safely away out of reach from harsh environments. The spot light module is made of 1070 pure aluminum and the mounting bracket is Stainless Steel. With the appropriate electrical components, the spot light and drive modules can be mounted up to 50 feet away from each other.

Specifications:

- Watts: 1000
- Input Volts: 110 – 277 VAC
- Input Amps: 8.33 @ 120 VAC
- Lumens: 146,000 @ 5000K
- Beam Angle: 35°
- Color: Black
- Rating: IP66
- Face Area: 22.5"
- Certification: UL, CUL
- Light shade included.



200 SERIES NAVIGATION LIGHTS

D.O.T. & Colreg's Approved For Vessels to 65'. Price of lights does not include bulbs. See below.

SIDE MOUNT

30-000R.....Port.....	165.95
30-001R.....Star.....	165.95
30-002R.....Masthead.....	165.95
30-003R.....Stern.....	165.95

BASE MOUNT

30-004R.....All Rd. Red.....	165.95
30-005R.....All Rd. White.....	165.95
30-006R.....All Rd. Green.....	165.95
30-007R.....Masthead.....	165.95
30-008R.....Stern.....	165.95
30-010R.....Port.....	165.95
30-011R.....Star.....	165.95
30-009R.....Towing.....	165.95



BULBS FOR 200 SERIES LIGHTS

30-016R.....12V x 25W.....	15.95
30-017R.....24V x 25W.....	13.95
30-018R.....32V x 25W.....	13.95
30-019R.....12V x 10W.....	12.23
30-020R.....24V x 10W.....	17.64

REPLACEMENT LENS, SOCKETS & O-RINGS

30-230P.....Star.....	85.95
30-231P.....Port.....	85.95
30-232P.....Masthead.....	85.95
30-233P.....Stern.....	85.95
30-234P.....All Rd. Red.....	85.95
30-235P.....All Rd. White.....	85.95
30-229P.....All Rd. Green.....	85.95
30-196R.....Replacement socket.....	41.20
30-236R.....Replacement O-Ring Seals.....	6.25



PIPE MOUNT BRACKET

Allows Perko Series 200 Base Mount Lights to be pipe mounted. 1/2" NPT Female Thread. Black metal base.

30-198R.....	21.55
--------------	-------

BULB WATTAGE INFORMATION FOR SERIES 200

All colored lights, and masthead lights use 25 watt bulbs.
Stern lights, all round white and towing lights use 10 watt bulbs.



1100 SERIES NAVIGATION LIGHTS

For vessels to 164'

D.O.T. & Colreg's Approved.

Features heavy-duty seals, ventilated to prevent condensation, rugged construction. 5 1/2" dia., 7 1/2" high. Pre-wired. Price of lights does not include bulbs.

See below for your bulb requirements.

30-038R.....Masthead.....	319.10
30-039R.....Stern.....	319.10
30-040R.....Port.....	319.10
30-041R.....Star.....	319.10
30-042R.....All Rd. White.....	319.10
30-043R.....All Rd. Red.....	319.10
30-044R.....All Rd. Green.....	319.10
30-163R.....Towing.....	358.95



BULBS FOR 1100 SERIES LIGHTS

30-045R.....12V x 30W.....	86.00
30-046R.....24V x 30W.....	86.00
30-047R.....32V x 30W.....	86.00
30-048R.....120V x 30W.....	86.00
30-197R.....Replacement Socket.....	49.05
30-201R.....Repl. Top Cap Seal (Rubber).....	10.45



COMBO NAV. LIGHTS "200 SERIES"

Navigation lights and fishing lights in one combined lantern. Lights can be turned on separately. Sold without bulbs.

All Round Green Over All Round Red	
30-013R.....	325.80
Replacement Lens	
30-243R.....	P.O.R.



170 SERIES NAVIGATION LIGHTS

Vessels to 65'

Perko quality in a stylish, economically priced light. High impact resistant plastic construction. Price includes 12V bulb.

30-152R.....Masthead.....	51.90
30-153R.....Stern.....	51.90
30-154R.....Port.....	51.90
30-155R.....Star.....	51.90



REPLACEMENT BULBS

For All 170 Series Lights (except stern)

30-156R.....Pkg. 2 / 12V.....	19.70
-------------------------------	-------

For Series 170 "Stern Light Only"

30-157R.....Pkg. 2 / 12V.....	23.20
-------------------------------	-------

For All 170 Series Lights (except stern)

30-356R.....Pkg. 2 / 24V.....	24.25
-------------------------------	-------

For Series 170 "Stern Light Only"

30-357R.....Pkg. 2 / 24V.....	24.25
-------------------------------	-------



ALL ROUND LIGHTS (FOR VESSELS TO 40')

Aqua Signal series 25. Base mount lights complete with 12V bulb. Approved light for fishing or navigation.

30-053M.....All Round White (Aqua Signal).....	46.95
30-054M.....All Round Red (Aqua Signal).....	48.95
30-091R.....All Round White (Imported).....	12.95



PERKO

SIDE LIGHTS

For Vessels to 40'. Sold as a set (1 port, 1 star), beautiful looking chrome plated lights. Complete with 12V bulb. Size: 5 1/2" x 3 1/8" x 1 3/8".

- 30-164R.....140.35 pr.
- 30-165R.....Repl. Bulb 2 pk.....18.40

PERKO



COMBINATION BI-COLOR LIGHT

For vessels up to 12M (39'). This light shows one side green, one side red on lens. 4"L x 3 1/8"W x 1"H. Comes with 12V bulb.

- 30-056R.....Perko Model - 12V74.80
- 30-165R.....Repl. Bulb 2 pk18.40

PERKO

NEW



PERKO NAVIGATION LIGHTS - HORIZONTAL

Polished Stainless Steel Top. Red and Green Lenses. Gold Plated Contacts. Visibility: 1 nautical mile. Voltage: 12 Volt (Bulb Included). Wattage: 10 watts (each light). Amperage: .80 amps (each light). Length: 4-1/4". Width: 2-3/8" Height: 1-1/2".

- 30-210R.....237.70
- 30-165R.....Repl. Bulb 2 pk18.40

PERKO



SIDELIGHTS

For Vessels to 40'. Black Plastic Construction. 3 1/4"H x 2 1/4"W x 1 5/8"H. Vertical Mount. Complete with 12V Bulb. Sold as set only.

- 30-214R.....104.30 pr.
- 30-215R.....Repl. bulb 2 pk.....24.80

PERKO



COMBINATION BI-COLOR LIGHT

Certified for use on vessels under 20 meters (65.6 ft.) in length. All black plastic construction. Measures: 3 1/2"L x 2 1/4"W x 13/16"H

- 30-245R12V51.30
- 30-165R.....Repl. Bulb 2 pk18.40

PERKO



BOW & STERN LIGHTS

Chrome plated brass top, black plastic base. 2 3/8" O.D. x 7/8" H. C/W 12V bulb.

- 30-176R.....Mast92.15
- 30-177R.....Stern.....92.15
- 30-165R.....Repl. Bulb 2 pk18.40

PERKO

LED



PERKO L.E.D. SIDE LIGHTS

Certified for use on power driven vessels under 20 meters (65') in length. Chrome plated bronze construction, low heat and long life. Uses 10% of the energy draw of standard lights. Sold per pair.

- Size: 3 1/4"L x 2"W x 1 1/8"H.
- 30-249R12V329.10 pr.

PERKO



TRI-COLOR LIGHT

For Vessels to 40' Red and green bi-light and white stern light. Designed for vessels "under sail only". C/W bulbs - 3 1/4" H.

- 30-175R.....96.75
- 30-165R.....Repl. Bulb 2 pk18.40

SHOP 24/7 FROM THE COMFORT OF YOUR OWN HOME

- Up to date Pricing
- New Products
- Stock Status
- Additional product info
- And more



www.mercersmarine.com



NAVIGATION LIGHTS

For Vessels to 65'

International approved, economically priced lights. Size: 4"H x 3 3/4"W x 3 1/4"D. Comes with 12V bulb.

30-028RPort.....	39.95
30-029RStar.....	39.95
30-030RMasthead.....	39.95
30-031RStern.....	39.95



Replacement Bulbs
(staggered base tabs)

30-032R12V.....	3.50
30-017R24V.....	13.95
30-018R32V.....	13.95



NAVIGATION LIGHTS

For Vessels to 40'. International approved, economically priced lights. 3"H x 2 3/4"W x 1 1/4"D. C/W 12V bulb.

30-033RPort.....	13.50
30-034RStar.....	13.50
30-035RMasthead.....	13.50
30-036RStern.....	13.50



30-037RRepl. bulb 12V.....	1.25 ea.
---------	--------------------------	----------



SIDE LIGHTS

Economically priced lights. Stainless steel construction. Sold as pair. 4 1/4"L x 1 3/8"H.

30-049R12V.....	28.95
30-170RRepl. Bulb.....	2.05

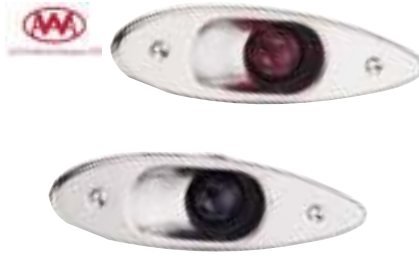

STAINLESS STEEL FLUSH MOUNT SIDELIGHTS

Voltage: 12 VDC. Beam Angle: 120°. Wattage: 1.2W.

Sold as a pair. 7 3/4" x 2 3/4" x 2 1/4"

30-057R12V.....	34.95
---------	---------------	-------

NEW



BOW & STERN LIGHTS

2.25" Dia x 1.4"H . Stainless Steel.

30-050RWhite Bow 225°.....	11.95
30-051RWhite Stern 135°.....	11.95

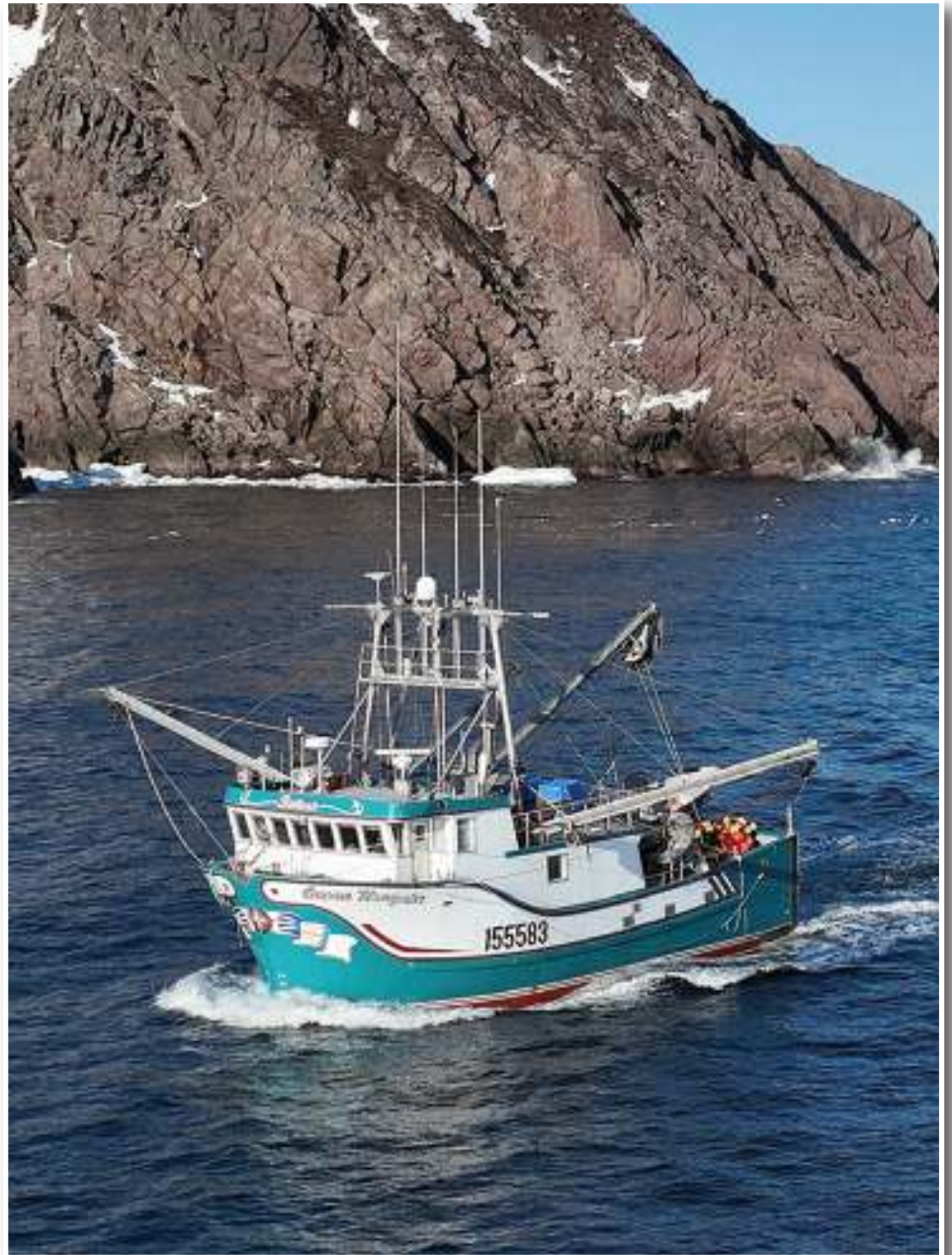



LED

L.E.D. NAVIGATION LIGHTS

12 V. For boats up to 12m. Plastic. Waterproof.
Approx Size: 3"H x 2 3/4"W x 1 1/4"D

30-617R	Port.....	18.95
30-618R.....	Starboard	18.95
30-619R.....	Mast.....	18.95
30-620R	Stern.....	18.95

LED



L.E.D. COMBINATION BOW LIGHTS

Chrome Plated Zinc with Plastic Base. LED Lifetime:
50000hrs. Beam Angle: 120°. 12V.
4"L x 3.25"W x 2"D.

30-622R	12V.....	24.95
---------------	----------	-------



LED

STAINLESS STEEL FLUSH MOUNT SIDELIGHTS

Voltage: 12 VDC. Beam Angle: 120°. Wattage: 1.2W.
Sold as a pair. 7 3/4" x 2 3/4" x 2 1/4"

30-191R.....	LED Model	39.95
--------------	-----------------	-------



LED

L.E.D. NAVIGATION LIGHTS

LENS ON PORT & STARBOARD IS WHITE, BUT WHEN
ON TURNS RED & GREEN.

Vertical Mount. Plastic. Splashproof, 8V TO 30V
Approx Size: 4 1/4"(W) x 3 5/8"(L) x 2 3/8"(H)

30-623R	Port.....	54.95
30-624R.....	Starboard	54.95
30-625R.....	Mast.....	54.95
30-626R	Stern.....	54.95



LED

L.E.D. POLE LIGHT

All round LED light. Adjustable ABS base. Stainless Steel
tubing. Voltage: 8V TO 30V. Water Resistant.

30-630R	9 1/2"	38.95
30-631R.....	25"	49.95

LED



"LED" COMBO 9.5" POLE LIGHT

Multi-purpose fold down light. 360 degree white lens.
Also has red/green insert which allows light to show
port, starboard and stern. 12V.

30-082R.....		26.95
--------------	--	-------



LED



L.E.D. POLE LIGHT

All round white high power LED. Water Resistant.
8V TO 30V. Available in 25" or 36". Socket included.

30-628R.....	25"	47.95
30-629R.....	36"	49.95



LED



L.E.D. POLE 9.5" POLE LIGHT

All round LED light. Stainless Steel tubing. 12V. Water
Resistant.

30-260R	9 1/2"	34.95
---------------	--------------	-------

PERKO

DELTA SERIES POLE LIGHT

Vessels under 65'

This light offers "2 globes", one with reduced glare while underway and a clear globe to light up the cockpit area when docked. Supplied with "2 Locking Collars" that fit most common bases. (Including 30-613 below) 40 degree adjustable head for proper alignment. Gold plated contacts assure trouble free operation. Complete with 12V bulb. Height 36".

- 30-608R..... 73.40
- 30-077R.....Repl. bulb (2 pk).... 13.70
- 30-078R.....Repl. Bk/Cl Lens.....17.15



PERKO

ALL ROUND WHITE TELESCOPING POLE LIGHT

Vessels under 65'

White translucent globe atop a 26 1/2" telescopic aluminum pole with locking collar. Complete with 12V bulb.

- 30-168R..... 69.80
- 30-136R.....Repl. bulb (2 pk).... 18.00
- 30-461R.....Repl. Lens..... 20.30



PERKO

ALL AROUND WHITE LIGHT

Vessels under 65'

Stow-a-way, plug in type. 3/4" dia. anodized tube. Clear fresnel globe. Includes base with waterproof cover. 16° rake. Gold plated contacts assure trouble free operation. Base (30-613) is included. Height is 30".

- 30-166R..... 118.10
- 30-167R.....Repl. bulb (2 pk).... 18.00



PERKO

LOCKING COLLAR POLE LIGHT MOUNTING BASE

Two pin plug in type base. Black plastic and chrome plated zinc alloy. Waterproof snap on cover. Supplied with pigtail leads. Fits pole lights 30-608 and 30-166 above.

- 30-613R..... 49.90



ALL ROUND WHITE TELESCOPING POLE LIGHT

One of our most popular models. Heavy quality chrome-plated brass with clear globe. Telescopic pole with locking base. Vertical height is 24". Complete with 12V bulb.

- 30-052R..... 68.95
- 30-259R.....12V Repl. Bulb..... 1.30
- New LED Model
- 30-174R..... 74.95

PERKO

ALL ROUND WHITE LIGHT

Vessels under 40'

Reduced Glare Design. Black plastic top with frosted globe. 3/4" anodized aluminum pole 13 3/8" high. Fold down design with locking knob. Contains notch for through-base wiring. Complete with 12V bulb.

- 30-365R..... 62.20
- 30-077R.....Repl. bulb (2 pk)..... 13.70
- 30-078R.....Repl. Lens..... 17.15



PERKO

ALL ROUND WHITE LIGHT

Vessels under 40'

White translucent globe with black plastic base. 5" high. Complete with 12V bulb.

- 30-024R..... 37.60
- 30-136R.....Repl. bulb (2 pk.).... 18.00
- 30-461R.....Repl. globe..... 20.30



FOLDING POLE LIGHT

All-Round Light, 12V 10W,

Plastic top and base with clear fluted reduced glare globe

- 30-257R.....9.5".....14.95
- 30-258R......25".....28.95
- 30-259R.....Repl. Bulb..... 1.30



PERKO



MASTHEAD / COURTESY LIGHT

Although this light is an actual "mastlight", we often find customers purchase it for a "Courtesy" light. Works well in cabins, cockpits or outside lighting needs. Mounts vertically as mastlight, vertically or horizontally as courtesy light.

- 3 3/4" x 1 1/2"W. 12V x 10W bulb.
- 30-212R..... 90.20
- 30-165R.....Repl. 12V bulb (2 pk)..... 18.40



MAST / STERN POLE LIGHT

Combination light. Fold down with locking knob. Chrome plated base with stainless steel tube. 10"high. Complete with 12V bulbs.

- 30-025R..... 32.95
- Replacement Bulb
- 30-079R.....12V/5W..... 2.95 ea.



COMBO 9.5" POLE LIGHT

Multi-purpose fold down light. 360 degree white lens. Also has red/green insert which allows light to show port, starboard and stern. 12V.

- 30-026R..... 23.95





RHYNO LED SCREW BASE BULB

Base Type: A19 screw. Beam Angle: 170°. Operating Temp: -20°C to 50°C. Voltage: 10 - 85VDC.

	Lumens	-	Equivalent	
7W	590 lm	-	40W	
12W	1000 lm	-	60W	
15W	1250 lm	-	100W	
30-747P	LED 7W, 590 Lumens			14.40
30-748P	LED 12W, 1000 Lumens			13.95
30-749P	LED 15W, 1250 Lumens			16.50



MEDIUM SCREW BASE BULB

30-103R	12V/25W	3.79
30-104R	12V/50W	3.79
30-105R	12V/100W	3.79
30-106R	24V/25W	3.79
30-107R	24V/50W	3.79
30-108R	24V/100W	3.79
30-109R	32V/25W	6.79
30-110R	32V/50W	6.79
30-111R	32V/100W	6.79



24 Volt

FLUORESCENT LIGHTING FIXTURE

ABS Base. Plastic Lens. DC-24V - 8 Watt x 2.

14 1/4" L x 3"W x 1 1/8"H
30-131R.....39.95



LED

LED INTERIOR LIGHT (DIMMABLE)

ABS Base. Plastic Lens. Beam angle: 120°

15 1/2" L x 3 1/3" W x 1 1/8" H
30-193R.....52.95



PERKO

PERKO BULKHEAD FIXTURE

Chrome plated construction with on/off switch. Supplied without bulb. See above for your bulb requirements.

30-064R.....30.95

LED

L.E.D. LIGHT RAIL

Plastic. Splashproof. Can Be Turned to 180°. Voltage: 12 VDC. LED Lifetime: 50000hrs. Effective Lumen: 30.5Lux
30-640R.....7".....19.95



LED

L.E.D. 13" INTERIOR LIGHT

Plastic. Beam Angle: 120°. Voltage: 10-30 VDC with 3P Switch. Size: 13" x 2 3/4". Effective Lumen: 535LM LED Lifetime: 50000hrs.

30-637R.....74.95



SWIVEL MOUNT LIGHT

Polished brass wall mount fixture complete with on/off switch and 12V halogen bulb. 3" dia. base x 4" x 5".

30-127R.....34.50

LED

L.E.D. ENGINE ROOM LIGHT

Aluminum Alloy, White Painting, PC Lens. Beam Angle: 110°. Voltage: 8-30 VDC. Splashproof.

Size Approx. 5 3/8" x 2 3/4"
30-634R.....76.95



LED

LED FLUSH MOUNT LIGHT

Aluminum alloy. 4 x 3 Watt cool white LED. 50000 hours. Beam angle : 110°. 426 lumen. 10 Watt. 8-30 VDC.

Outside flange 6 7/8" L x 2 5/16" W
Cutout 4 1/2" L x 1 7/8" W
30-654R.....49.95



LED

L.E.D. CHART LIGHT

Goose neck light. Ideal for chart reading or compass light. Adjustable neck with on/off switch on base.

30-121R12V.....26.95



Shop or Browse Online 24/7 at mercersmarine.com



DOME LIGHT

Standard Models (1 Bulb)

Polished stainless steel construction, and on/off switch. Light complete with 12V bulb. 5" lens, 6.75" (Dia. Base)

For other voltages see bulbs below.

30-119R5" Lens...(12V)27.95



NIGHT VISION MODEL (2 Bulbs)

Same specs as standard dome light only this light is supplied with one red and one white bulb which can be operated separately. Perfect light for preventing glare in the wheelhouse when using only the red bulb.

5" lens, 6.75" (Dia. Base)

30-120R12V32.95



BRASS MODEL (1 Bulb)

Brass construction, and on/off switch. Light complete with 12V bulb. 5" lens, 6.75" (Dia. Base)

For other voltages see bulbs below.

30-369R12V34.95



LED

LED DOME LIGHT

LED Lifetime: 50000hrs. Beam Angle: 120°. Color Temperature: 4500K. Size: 5.9" (Dia.) lens, 6.6" (Dia.) overall. Effective Lumen: 268LM. Wattage: 3.3W

30-118R12V31.95



LED

LED "NIGHT VISION" DOME LIGHT

White and Red LED's. LED Lifetime: 50000hrs. Beam Angle: 120°. Color Temperature: 4500K. Size: 5.9" (Dia.) lens, 6.6" (Dia.) overall. Effective Lumen: 268LM. Wattage: 3.3W

30-122R12V37.95



3" DOME LIGHT

Standard Models (1 Bulb)

Polished stainless steel construction, and on/off switch. Light complete with 12V bulb. 3" Lens, (4.37" Dia. Base) For other voltages see bulbs to the left.

30-605R3" Lens...(12V)14.95



BRASS OIL LAMP

Heavy quality, wall-mounted, Gimballed Brass oil lamp complete with chimney and heat shield. Burns kerosene or lamp oil. Height 10".

30-138RComplete Unit119.95

30-139RRepl. Glass Chimney11.95



REPLACEMENT DOME LIGHT BULBS & LENS

30-115R12V(5" Lens)1.10

30-116R32V(5" Lens)6.95

PERKO



NEW

PERKO LED FLUSH COURTESY LIGHT

Snap-On Front Cover Conceals Mounting Screws. Diffusion Lens. flush Mounting. Easy Installation. Supplied with 7" Pig Tail Wire Leads. 12 Volt LED. Length: 2-1/4". Width: 2-1/4". Installs in 1-3/4" Diameter Hole.

30-253R38.20

PERKO



PERKO ADJUSTABLE UTILITY LIGHT

Chrome Plated Zinc Alloy. Shield swivels to change position. 12 Volt, 7 Watt Bulb Included.

O.D. Overall: 2-5/8". Length Neck: 3/4". O.D. Neck: 7/8" Screw Size: #6.

30-256R41.95



LED

L.E.D. INTERIOR WALL LIGHT

With Plastic Shade. Brass body. **Voltage: 8-28 VDC**
 Beam Angle: 120°. Effective Lumen: 90LM. LED Lifetime: 50000hrs. Approx Size: 7"(H)
 30-639R.....48.95



LED

L.E.D. STAINLESS STEEL WALL LIGHT

With Glass Shade. Beam Angle: 110°. LED Lifetime: 50000hrs. Effective Lumen: 86LM. Wattage: 3.1W.
Voltage: 8-30 VDC. Approx Size: Base 2 1/8" Dia; Height 3 1/2"(H.)
 30-638R.....48.95



LED

L.E.D. STAINLESS STEEL WALL LIGHT

With Glass Shade. LED Lifetime: 50000hrs. Beam Angle: 110°. Effective Lumen: 74LM. Wattage: 3.1W. **Voltage: 8-30 VDC.** Approx Size: Base 2 1/8" Dia; Height 4"
 30-636R.....48.95



CABIN LIGHT

Polished brass body. On/off switch. Attractive white plastic shade. 7 1/2"H x 4 1/4"D x 2 3/4" base. Comes with 12V/10W halogen bulb.
 30-114R.....38.80



LED

L.E.D. CEILING LIGHT WITH SWITCH

Size: 4 1/3"(Dia.). For surface mount. Material: Plastic. LED Type: "2835" 0.2W LED. LED Lifetime: 50000hrs. Beam Angle: 120°. Color Temperature: Nature white 4500K. Effective Lumen: WH: 230LM/ RD: 30LM. Wattage: 1.15W. Voltage: 12 VDC. Splashproof
 30-632R.....19.95



LED

L.E.D. CEILING LIGHT WITH SWITCH

3 1/2" Diameter. LED Lifetime: 50000hrs. Effective Lumen: 45LM. Wattage: 0.5W. **Voltage: 12 VDC.** LED Type: 3 x "2835" 0.2W LED
 30-614R.....15.95



LED

L.E.D. DOME LIGHT WITH SWITCH

Effective Lumen: 272LM. Size: 5.5" Dia. LED Type: 20 x 0.2W "2835" Nature white LED. LED Lifetime: 50000hrs. 12 Volt.
 30-194R.....21.95



LED

L.E.D. INTERIOR ROTO LIGHT

360 degree eye balled rotation revolving light for perfect angle of illumination. Plastic Chrome. LED type 1 x 1W in PCB. Lifetime : 50000 hrs. Beam angle: 15 degrees. Effective Lumen: 60LM. **Voltage: 9-30 VDC.** Splashproof. Approx Size 4 3/4" x 2 3/4"
 30-642R.....39.95



LED

L.E.D. SENSOR LIGHT

For Flush or Surface Mount. Material: PC. LED Type: 1 x 1W Warm White LED. LED Lifetime: 50000hrs. Beam Angle: 110° Effective Lumen: 40LM. Effective Wattage: 1.2W **Voltage: 8-30 VDC.** Splashproof. 3"Wide
 30-648R.....21.95



LED

L.E.D. MINI READING LIGHT

Chrome Plated. Beam Angle: 110°. **Voltage: 8-30 VDC.** Approx Size: 1 3/4" Base Dia. 3 3/8"(H)
 30-635R.....52.95



MARINE BOAT CABLE - 2 CONDUCTOR/FLAT

Most commonly used wiring for commercial boats and pleasure crafts. Stranded tin copper conductors, colour coded, P.V.C. insulated jacket. UL listed 600V. 100 ft. coils.

28-003R#1667.95
28-002R#1489.95
28-001R#12132.95
28-000R#10219.95

BOATBUILDERS - Eliminate waste, buy 1000 ft. coils.

28-985R#16P.O.R.
28-986R#14P.O.R.
28-987R#12P.O.R.



MARINE BOAT CABLE - 2 CONDUCTOR/ROUND

Same specifications as flat type above. Allows for good fit when passing through deck fitting, cable clamps, etc. Fits many navigation lights which have O'ring seals. Comes in 100 ft. coils.

28-239R#16129.95
28-240R#14179.95
28-241R#12254.95



MARINE BOAT CABLE - 3 CONDUCTOR/FLAT

Same specifications as wire above except 3 conductor. Comes in 100 ft. coils.

28-139R#14155.00
---------	----------	-------------



PRIMARY WIRE

Flexible tinned conductor wire with PVC jacket. Resists oil, acid, and salt.

28-229R16 gauge/black0.28/ft
28-230R14 gauge/black0.41/ft
28-231R12 gauge/black0.59/ft
28-232R16 gauge/white0.28/ft
28-233R14 gauge/white0.41/ft
28-234R12 gauge/white0.59/ft



BATTERY ALLIGATOR CLIPS

Approximately 3" long.

28-292RRed1.29
28-293RBlack1.29

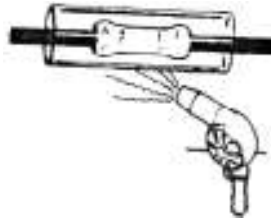

HEAT SHRINK TUBING

A single wall polyolefin heat shrink tubing used for waterproofing electrical connections. Also used on rope whip ends. Great to stop your mooring lines from unraveling. Just insert over rope or electrical connection and apply heat. A cigarette lighter will work.

28-277R1/8"1.15/ft.
28-278R3/16"1.75/ft.
28-279R1/4"2.10/ft.
28-280R3/8"2.25/ft.
28-281R1/2"2.75/ft.
28-282R3/4"3.50/ft.

ELEKTRALINK HEAT SHRINK SOLDER SYSTEM

Not only does this system offer heat shrink waterproof protection, but soldered connections as well.

- Solders and seals in one easy step.
- Works easily with cigarette lighter.



ELEKTRALINK RING TERMINALS

28-264R16/14 x #81.14
28-265R16/14 x #102.20
28-266R12/10 x #101.45



ELEKTRALINK SPADE TERMINALS

28-267R16/14 x #101.27
28-268R12/10 x #101.56



ELEKTRALINK QUICK DISCONNECT

28-269R16/14 Male2.50
28-270R12/10 Male1.50
28-271R16/14 Female1.95
28-272R12/10 Female1.75



ELEKTRALINK BUTT CONNECTOR

28-273R16/141.85
28-274R12/102.75



RING TERMINALS

28-256R16/14 9A x #80.29
28-257R16/14 9A x #100.29
28-258R12/10 9A x #100.44



SPADE TERMINALS

28-259R16/14 x #80.35
28-260R16/14 x #100.35
28-261R12/10 x #100.46



BUTT CONNECTERS

28-262R16/14 9A0.23
28-263R12/10 9A0.41



STANDARD CABLE TIES

28-010R7" long0.09
28-127R11" long0.16
28-128R14" long0.20



SCREW MOUNTING CABLE TIES

28-011R7"0.18
---------	---------	-----------



CUSHION CLAMPS

28-330R1/4"0.80
28-331R3/8"0.95
28-332R1/2"1.15
28-334R3/4"1.39
28-335R1"1.59
28-336R1 1/4"1.65
28-337R1 1/2"1.99



NYLON CABLE CLAMPS

28-004R1/4"0.11
28-005R5/16"0.11
28-006R3/8"0.13
28-007R1/2"0.14
28-008R3/4"0.24
28-009R1"0.30



DECK OUTLETS

Watertight way to pass wire through deck.

28-563R.....	1/4"	11.50
28-564R.....	5/16"	11.50
28-565R.....	3/8"	11.50
28-566R.....	1/2"	11.50
28-567R.....	5/8"	18.95
28-568R.....	3/4"	18.95



28-430



28-427

CIGARETTE LIGHTER & SOCKET WITH W/P CAP

Lighter has chart light. Socket complete with weatherproof cap allows GPS & phone plug in. 12 VDC.
28-430R.....Stainless Steel.....29.95

POWER SOCKET

Stainless steel construction, complete with cap.
28-427R.....14.95



MARINCO



MARINCO SEALINK LOCKING SYSTEM

SEALINK products are manufactured from corrosion resistant marine grade
28-944P.....SEALINK Plug.....15.95
28-945P.....SEALINK Socket.....17.50



MIDGET SMALL CLAM VENT/OUTLET

Small vent quite often used to cover wiring such as coax cable, etc. 1 1/2"L x 1 5/8"W
28-118R.....1.39



CIG. LIGHTER PANEL/USB PORT

Weatherproof Panel with USB Port. 12 Volt. Completed with 1 x plastic cigarette socket + 1 x USB (Dual port).
Size: 3 1/8" x 2 7/16"
28-062R.....24.95



DUAL USB CHARGER SOCKET

Easy to install in existing 12V DC socket hole. Compatible with popular mobile devices. Protective Cap.
Maximum output current : 2.1Amp.
Output voltage : 5V DC +/-5%.
Parasitic Current Draw : 15mA
28-1308P.....12/24V Only (Model 1016).....36.95

PERKO



WATERTIGHT DECK CONNECTOR

Flange gasket with integral waterproof cap for base when plug is removed. Rated for 15amps at 12, 24 & 32V.
28-289R.....52.00



PLASTIC POWER SOCKET C/W CAP

28-426R.....12V.....4.50



DUAL USB CHARGER - SOCKET MOUNT

Charges at the speed required by specific devices. Over temperature protection. Protective dust cap keeps debris and moisture out. Conformal coated circuit board for the marine environment. Mounts in a 1-1/8" hole.
28-1307P.....12/24V (Model 1045).....69.95



TWIN POWER SOCKET

Comes with cigarette plug.
28-323R.....9.95



DUAL USB CHARGER WITH CAP

Voltage: 6-30 VDC. Amp: 3.1 Amp. Approx Size: 2" x 1" x 2"
28-1600R.....17.95



SOCKET WITH BATTERY CLIPS

28-432R.....14.95



PUSH BUTTON SWITCH

Constructed of brass and chrome plated brass. Ideal for horns. 12V.

28-021R.....17.95



STARTER SWITCH

Constructed of brass for marine ignitions. 3 pole, 2 keys.

28-022R.....32.95

28-023RWith W/P Rubber Cap34.95



MOMENTARY TOGGLE SWITCH WITH W/P CAP

2 pole. 12 Volt, 15 amp. (ON)- OFF-(ON): Switch must be held in UP or DOWN position to activate.

28-060R..... 6.95



PUSH/PULL SWITCH (12V)

Brass body-Chrome plated brass knob. 15A at 12VDC.

28-018R.....2 Pole13.95

28-019R.....3 Pole18.95



IGNITION KILL SWITCH W/LANYARD

Includes 7 keys that fit Johnson/Evinrude, Mercury, Yamaha & Honda Kill Switches

28-125R.....7.95



MOMENTARY PUSH BUTTON SWITCH

12V, 5 amps, made of chrome plated brass housing and plastic button. 2 5/8" L x 1 1/2" Dia.

28-119R..... 5.50



TOGGLE SWITCH

Nickel plated brass toggle with chrome plated face nut. Single pole, single throw. Rated at 20A at 12, 24, 32 VDC.

28-037R.....37.65



DIELECTRIC SILICONE COMPOUND

An excellent lubricant and sealant that prevents corrosion and reduces short circuits resulting from water intrusion. Fights oxidation to improve conductivity. Penetrates aluminum oxide to maintain current paths.

28-097K9.5 g12.95



TOGGLE SWITCH

Metal Construction

Metal body, 2 pole, 15 amps, 12 VDC.

28-165R.....Metal6.95



TOGGLE SWITCH

28-025RPlastic.....3.65

SHOP 24/7 FROM THE COMFORT OF YOUR OWN HOME

- Up to date Pricing
- New Products
- Stock Status
- Additional product info
- And more



www.mercersmarine.com



Designed to ABYC standards and assure quality construction at an affordable price. Coated for corrosion resistance then finished with a slate color two-part paint. Equipped with an "ON" indicator LED. (amber for DC circuits and green for AC circuits) All panels have heavy #10 stud terminals for wire connections. Each panel comes with a "BACKLIGHT SYSTEM".



24 CIRCUIT DC PANEL

12/24 Volt. 24 circuit panel. 15 – 15amp breakers installed, bus bars installed, pre-wired. Labels included, label positions are back lite. All positive, negative and grounding buses installed, fully pre-wired. Panels with meters include toggle switch for mounting up to 3 battery banks. All circuit label positions are backlit on standard panels - No kit required. "ON" indicating LEDs installed in all circuit positions.

Maximum Amperage - 100A per bus
H 7.50" x W 14.75"

Model 8264

28-479M.....1095.00



24 CIRCUIT AC/DC PANEL

This panel is designed for boats with both AC and DC electrical systems.

The "AC" part of the panel has 8 circuit breaker positions with reverse polarity indicating red LEDs and a 0-150 volt AC voltmeter. 1, 30 amp double pole AC main breaker and 3, 15 amp breakers are provided. There are 3 AC blank positions available.

The "DC" side of the panel has 16 circuit breaker positions. 10, 15 amp breakers are provided along with 6 blank positions. 8 to 16 volt DC voltmeter with a 3-position switch to monitor up to 3 battery banks and a 0 to 50 amp ammeter are included. Accepts optional backlight system model 8065 (3 required). Comes with 30 AC labels and 30 DC labels. 14 3/4" W x 10" H.

Model 8084

28-474M 12 VDC / 120 VAC.....1420.00



13 CIRCUIT DC PANEL

Comes with an 8-16 DC voltmeter with 3-position switch to monitor up to 3 battery banks and a 0 to 50 amp DC ammeter with remote shunt. Includes 10, 15 amp breakers and 3 blanks. Ready for installation of optional model 8065 backlight system (two required) 30 labels included. 10 1/2"W x 7 1/2"H.

28-478M.....Model 8068, 12 VDC.....899.00



13 CIRCUIT AC PANEL

Comes with a reverse polarity indicating red LEDs, 0 to 150 AC voltmeter and a 0 to 50 AC ammeter with remote sensing coil. Supplied with 1, 30 amp (double main) breaker, 8, 15 amp breakers and 3 blank positions. Pre wired and ready to accept model 8065 backlight system (2 required). Comes with 30 AC labels. 10 1/2"W x 7 1/2"H.

28-472M #8076 - 120 VAC895.00



10 CIRCUIT DC PANEL

Same specs. as the 13 circuit panel above only supplied with 7, 15 amp breakers and 3 blanks. If installing optional "BACKLIGHT SYSTEM, only 1 model 8065 is required. 30 labels included. 5 1/4"W x 11 1/4"H.

28-477M.....Model 8082, 12 VDC.....710.00



8 CIRCUIT AC PANEL

Comes with a reverse polarity indicating LEDs. Supplied with 1, 30 amp (double main) breaker, 3, 15 amp breakers and 3 blank positions. Accepts model 8065 backlight system. Comes with 30 AC labels. 5 1/4"W x 7 1/2"H.

28-470M.....Model 8027, 120 VAC.....365.00



8 CIRCUIT DC PANEL

All buses installed and fully pre-wired. Comes with 5, 15 amp breakers and 3 blanks. Accepts optional backlight system model 8065. 30 labels supplied. 5 1/4"W x 7 1/2"H.

28-476M.....Model 8023, 12 VDC.....359.00



CIRCUIT BREAKER TOGGLE GUARD

Protects circuit breakers from accidentally being switched ON or OFF. Fits all standard single pole circuit breakers. Mounting screws supplied. Two toggles shown in photo.

28-072RModel 4100.....5.75/Each



WEATHERDECK FUSE PANELS

Designed for flybridge and open cockpit applications. Independent label backlighting circuit for remote lighting and dimming. Constructed of corrosion resistant materials and weather resistant face plate. Panel can be mounted in four different orientations. Integrated ATO/ATC fuse based circuit protection.

28-513R.....4 Pos. #4304 (3.875" x 4.3")143.00
 28-514R.....6 Pos. #4306 (3.875" x 6")199.00
 28-515R8 Pos. #4308 (3.875" x 7.7")283.00



WEATHERDECK DIMMERS

Designed for flybridge and open cockpit applications. Independent label backlighting allows switching and dimming. Constructed of corrosion resistant materials and weather resistant face plate. Compatible with all Blue Sea Systems Digital Dimmers. Each panel can be mounted in four different orientations. Push button thermal trip, manual reset, 15 amp breakers.

28-510R4 Pos. #4374 (4.25" x 4.3")176.00
 28-511R6 Pos. #4376 (4.25" x 6")216.00
 28-512R8 Pos. #4378 (4.25" x 7.7")305.00



BREAKER PANEL BACK COVERS

Lightweight and easily installed cover provides insulation and mechanical protection for exposed panel backs. Black ABS material is easily drilled.

28-483R#4027 (5 1/4" x 7 1/2")47.95
 28-484R..... #4028 (7 1/2" x 10 1/2")125.95



12V DC SOCKET AND DUAL USB CHARGER

This panel has 1 12V socket that can supply up to 15 Amps and 1 dual USB socket that can supply up to 2.1 amps. Great for charging cell phones, tablets, and other electronic devices. Can integrate into Blue Sea 360 Panel Systems. 4.75" H x 4.88" W x 1.50" D.

28-1306PModel 1478.....103.95



BACKLIGHT LABEL SYSTEM

Model 8065 fits panels with 3, 5, or 8 label positions. Model 8069 fits panels with 10 positions. Backlight board is mounted between the two bus blocks on the back of the panel; boards connect to 12VDC supply via #6,18AWG leads. Each label backlight draws only 5 mA.

28-481R.....Model 8065, 12 VDC32.95
 28-482R.....Model 8069, 12 VDC34.95



WATERPROOF SWITCH PANELS

Especially designed for flybridge or open cockpit applications. Heavy 1/8" aluminum face plate with two part polyurethane slate finish. Waterproof Contura switches with "ON" indicating LEDs embedded in switch. Supplied with waterproof mounting gaskets and set of 30 DC labels (not backlightable). Accepts AGC fuses up to 20 amps.

6 Circuit Vertical Model
 28-467R#8053 (5 1/4" x 7 1/4")263.00
8 Circuit Horizontal Model
 28-468R#8261 (9 3/8" x 3 3/4")333.00
Replacement Fuse Holder
 28-469R20 Amp5.95



SAFETY HUB 150 FUSE BLOCK

An ignition protected fuse block with screw termination safe for use on gasoline powered boats. Accepts four AMI or MIDI Fuses for high-amp circuits up to 200A. Accepts six ATO or ATC Fuses for circuits up to 30A including bilge pumps, electronics and lights. Sealed cover protects fuses from the harsh marine environment and satisfies ABYC/USCG insulation requirements. Negative bus provides common location for negative connection.

28-487RModel 7748.....215.00



ML-ACR AUTOMATIC CHARGING RELAY

500 Amp magnetic latching (bi-stable) relay automatically combines batteries during charging and isolates batteries when discharging and when starting engine. Includes ML-Series Remote Control Contura Switch PN 2146. Automatically manages the charging of two large battery banks. Allows paralleling of battery banks for emergency starting. 500 Ampere continuous rating to support high-output alternators. LED output to remotely indicate when batteries are combined, isolated, in voltage lockout, or in Start or Engine isolation.

28-1310R12V - 500 Amps379.00



AUTOMATIC CHARGING RELAY

12/24V DC 65A

The Mini Automatic Charging Relay is designed to manage the charging current from alternators up to 65 Amps found on most outboards and many inboard engines.

Start Isolation protects sensitive electronics by temporarily isolating house loads from the engine circuit during engine cranking, protecting the house circuit from voltage sags and spikes.

The compact design allows for three mounting styles: surface, rear, or panel mount. The M-ACR is also available as a module in a Custom 360 Panel.

Features

- Senses charging on two battery banks
 - Pull off and snap on insulating cover
 - LED indicates ACR status
 - 1/4" x .032" male quick connect terminal for ground
- 28-571R.....(Model #7601)121.95



FUSE BLOCK SYSTEM

Polycarbonate base with clear cover. Cover insulates all conductive parts, satisfying ABYC / USCG requirements. Label slots are recessed and accept standard Blue Sea labels. Tin-plated, copper buses and beryllium copper fuse clips give full 30 amp rating per circuit. Max amperage for the total fuse block is 100 amps. Max voltage is 32VDC. 6 circuits. 3 1/4"W x 5"H x 1 1/4"D.

28-488RModel 5015 (with ground)66.50
28-489RModel 5018 (w/o ground).....56.50



ATC

Clear insulating cover with label recesses accept Small Format Labels. Cover Satisfies ABYC/USCG requirements for insulation. Tin-plated copper buses and fuse clips give 30 Amperes rating per circuit. Accepts ATO and ATC fast acting blade fuses. 20 write-on circuit labels included. Tin-plated copper buses and fuse clips give 30 Amperes rating per circuit. Accepts ATO and ATC fast acting blade fuses.

28-534RModel 5025 , 6 Circuit.....71.95
28-535RModel 5026 , 12 Circuit.....89.95



PANEL LABELS

Blue sea system label set contains 30 of the most commonly used labels. Tough weather-proof lexan material. Backlightable, with backlight label system.

28-485RDC label kit 803014.95
28-486RAC label kit 803114.95



DC WATERPROOF SWITCH PANELS

Black aluminum panel with UL approved waterproof rocker switches with on/off LEDs and AGC type fuse holders. Supplied with 30 labels. 12VDC.

3 Circuit Model

28-055R.....3 3/4" x 5 1/4"40.95

6 Circuit Model

28-056R.....5 1/4" x 7 1/2"69.95



WATERPROOF SWITCH PANEL WITH USB PORT

Material: Aluminum plate. Waterproof switch with LED indicator. Cabled and equipped with fuses: 15A x 5pcs. Completed with 1 x USB (dual port) with rubber cap. Voltage: 12VDC. USB: 12V/1A. Supplied with 30 labels.

5 Circuit Model

28-054R.....7 1/2" x 5 1/4"69.95



CIRCUIT BREAKER PANEL

An economical breaker panel with 6 lighted rocker switches & aluminum face plate. 4 1/2"W x 6 1/2"H.

28-039R12V.....37.95



LED LIGHTS



WORK BOAT PANELS

HD engraved composite backing panels. High load toggles with waterproof switch-boot. Highly visible red LED indicator lights. 12/24V

28-360M.....Electric Clutch69.95

28-361MWash Down.....69.95

28-362M.....Electric Clutch/Wash Down.....139.95

28-363M6 Position Nav Lights229.95



Replacement Fuse Holder
28-218

ECONOMY FUSE PANEL

Comes with 6 fused switches, black backing, good value. Measures 4 1/2"W x 6 1/2"H.

28-040R12V.....34.95

28-218R Repl.Fuse Holder (5 Amp).....2.50

28-287R Replacement Switch.....3.95



WATERPROOF ROCKER SWITCH

21A/ 14VDC, w/1 x Red LED Indicator. Terminals: Silver Plated Brass. PCB Inside. Snap-In Mounting, Easy To Install switch Into Panel or wall mount. Waterproof IP66 and Dustproof. Fits 28-055 & 28-056 panels above.

28-121RSwitch Only.....6.95

28-122RFrame Box.....1.29



THERMAL CIRCUIT BREAKER SURFACE MOUNT

Ignition protected - Safe for installation aboard gasoline powered boats. Meets SAE J1171 external ignition protection requirements. Weather Resistant. Combines switching and circuit breaker function into one unit.

"Trip Free" - cannot be held closed after trip.

28-394R50 amp79.95

28-395R60 amp79.95

28-396R80 amp79.95

28-397R100 amp79.95

28-398R120 amp79.95

28-399R150 amp79.95



HEAVY DUTY CIRCUIT BREAKER

28-041R5 Amp25.50

28-042R10 Amp25.50

28-043R15 Amp25.50

28-044R20 Amp25.50

28-045R25 Amp25.50

28-046R30 Amp25.50

28-047R50 Amp25.50

28-048R100 Amp (single)62.95



LED INDICATOR LIGHTS

Install in any Blue Seas panel or in material of any thickness with an 11/64" diameter mounting hole.

28-057R Amber (12V/24V)4.95

28-076R Red (12V/24V)4.95

28-077R Green (12V/24V)4.95

28-078R Amber (120V)4.95

28-058R Green (120V)4.95

28-059RRed (120V)4.95



250 AMP BUS BAR

Single tin-plated brass "Maxibus" on a lexan base. 12, #10 terminal screws. Maximum 48 VDC, 300 VAC. Mounting base countersunk for #10 screws. Optional protective cover sold separately. Approx. size is 5"L x 1 7/8"W.

28-494R.....	Model 2105.....	88.95
Protective cover		
28-495R.....	Model 2718.....	54.95



150 AMP BUS BAR

Combines negative and positive buses on one block. Clear polycarbonate cover snaps on to meet Coast Guard and ABYC insulation requirements. Each tin-plated brass bus is equipped with 5, #10 screw terminals and a heavy 1/4" stud. Maximum 48 VDC, 300 VAC and 150 amps continuous. Approx. size is 4 7/8"L x 2 1/2"W.

28-492R.....	Model 2722.....	46.95
--------------	-----------------	-------



100 AMP BUS BAR

Combines negative and positive buses on one block. Each tin-plated brass bus is equipped with 10, #8 terminal screws. Maximum 48 VDC, 300 VAC. 100 amps continuous. Optional protective cover is available, see below.

Approx. size is 5"L x 1 7/8"W.		
28-490R.....	Model 2702.....	34.95
Protective cover		
28-491R.....	Model 2710.....	24.50



600 AMP BLUE SEAS BUS BAR

4 terminals
600 Amp/4 Terminals

28-516R.....	Model 2104.....	173.00
Cover		
28-517R.....	Model 2708.....	37.50



BLUE SEAS BUS BAR & COVER

The industry standard busbar for positive distribution. The industry standard busbar for the collection of negative or AC ground circuits.

150 Amp/4 Terminals		
28-498R.....	Model 2307.....	41.95
150 Amp/10 Terminals		
28-496R.....	Model 2300.....	31.95
150 Amp/20 Terminals		
28-496R.....	Model 2312.....	50.95



HEAVY DUTY HI-AMP FUSE HOLDER

Designed to be installed between your inverter and the battery DC output wire.

28-200R.....	Fuse Holder.....	37.50
28-550R.....	100 Amp. Fuse.....	15.50
28-551R.....	125 Amp. Fuse.....	15.50
28-552R.....	150 Amp. Fuse.....	15.50
28-554R.....	200 Amp. Fuse.....	15.50
28-555R.....	300 Amp. Fuse.....	15.50



BLUE SEA TERMINAL BLOCK - 30 AMP - 8 CIRCUIT

Closed back design completely insulates power from the mounting surface. Each screw pair is one isolated circuit. Jumpers allow creation of common circuits.

Length is 5.50". Maximum Voltage-600V AC/DC
Continuous Rating - 30A.

28-493R.....	Model 2508.....	15.50
--------------	-----------------	-------



TERMINAL BLOCK

10 gang, with brass bolts. 30 amp.

28-051R.....		27.95
--------------	--	-------



CLASS-T FUSE BLOCK

The fuse system recommended by most inverter manufacturers for high speed response to short circuits. Clear insulating cover, satisfies ABYC/USCG requirements.

For use on systems up to 160 Volts DC. Large 3/8"-16 stud terminals accept ring terminals for wire up to 4/0 AWG. Large heat dissipating tin-plated copper mounting blocks. Two # 8 accessory terminals located on each end.

28-543R.....	Model 5502 Fuse Block.....	84.50
28-544R.....	225 Amp. Class T Fuse.....	69.95
28-545R.....	250 Amp. Class T Fuse.....	69.95
28-546R.....	300 Amp. Class T Fuse.....	69.95
28-547R.....	350 Amp. Class T Fuse.....	69.95
28-548R.....	400 Amp. Class T Fuse.....	69.95





POWERPOST CABLE CONNECTOR

Connects high amperage cables securely.

28-518R.....3/16" Post.....	13.95
28-519R.....1/4" Post.....	13.95
28-520R.....5/16" Post.....	20.95
28-521R.....3/8" Post.....	20.95



POWERPOST "+" CABLE CONNECTOR

150 Ampere bus allows small wire connections at high amperage cable connections.

28-524R.....3/8" Post.....	39.95
----------------------------	-------



CABLECAP STUD INSULATORS

Insulate stud type connectors on alternators, starters, windlasses and other high amperage devices

28-525R.....18 - 10 Red	3.95
28-526R.....18 - 10 Black	3.95
28-527R.....8 - 4 Red	3.95
28-528R.....8 - 4 Black.....	3.95
28-529R.....2 - 2/0 Red	4.95
28-530R.....2 - 2/0 Black.....	4.95
28-531R.....3/0 - 4/0 Red	5.25
28-532R.....3/0 - 4/0 Black.....	5.25



PANEL SWITCH

Perfect for generator starters, bilge pumps, horns, wipers, engine controls and any other application that requires switching action other than ON-OFF or different pole configuration separate from circuit protection.

Panel switches mount in A-Series toggle circuit breaker apertures. Supplied with mounting adapter for standard 5/8" circuit breaker mounting hole. Nickel-plated brass and phenolic non-corrosive construction.

Note : (On) = Momentary, Must be held.

28-540R (#8200) Push Button Off - (On)	10.95
28-541R..... (#8204) Toggle On - Off	9.95
28-542R (#8207) Toggle (On) - Off - On.....	20.50



GROUND PLATES

Modern marine electronic equipment requires adequate grounding to operate efficiently. Our "Ground Plates" provide this assurance as well as providing a lightning ground.

28-073R.....8" x 2 1/2" x 1/2"	345.00
(Equivalent to 20 Sq. Ft. of Copper)	
28-074R.....12" x 3" x 1/2"	549.00
(Equivalent to 40 Sq. Ft. of Copper)	
28-075M.....18" x 6" x 1/2"	1075.00
(Equivalent to 100 Sq. Ft. of Copper)	

ProMariner



BATTERY ISOLATORS

These solid state devices allow you to connect your engine alternator directly to both batteries without fear of overcharging or of one higher-charged battery discharging into the other lower-charged battery. Using this unique device, the batteries are electrically isolated from each other. Both your batteries are always automatically being charged whenever the engine is running. For 6, 12, 24, 32 volt negative ground systems with one alternator and two batteries.

May not be exactly as shown.

28-070P.....70 Amp (Shown Above)	156.00
28-071P.....130 Amp.....	219.00
28-224P.....200 Amp.....	310.00



ORION DC-DC CONVERTERS

Input voltage 20-35 VDC; Output voltage 13.6 VDC Prevents irreparable damage to your 12V system that an inferior power supply can cause. Delivers a stable 12V supply from a 24V system.

28-1073J.....24/12 25 Amp	99.00
28-1074J.....24/12 40 Amp	141.00
28-1075J.....24/12 70 Amp	199.00



SAMLEX 10 AMP. AC/DC POWER SUPPLY

This high efficiency AC-DC power converter provides a highly regulated output DC voltage of 13.8 Volts at 10 Amps with an AC input of 120 Volts, 60 Hz.

These advanced switch-mode DC power supplies were designed specifically for use with land mobile radio. The power supplies produce clean reliable power and are highly filtered to suppress RFI. The unit comes with a detachable power supply cord with NEMA 5-15P plug. Features include over-current, short-circuit and over-voltage protection. The AC-DC power supply conforms to FCC Part 15(B), class B digital device.

28-101K.....	225.00
--------------	--------



ProMariner

GALVANIC ISOLATOR

Galvanic Isolators will interrupt galvanic current flow with other boats at a marina when installed on a boat which is connected to AC Shore Power. This technology maintains AC safety ground and solves the most common forms of corrosion and premature zinc loss within a boats bonding system. Unit installs easily and does not require a dedicated monitor to verify the operational status of the galvanic isolator. We strongly recommend the use of this product when installing hot water heaters. Used with 30 Amp Shore Cord Applications.

28-322P.....Model 4531001.....	505.00
--------------------------------	--------

ANCOR



STANDARD BATTERY CABLE

Marine Grade Battery Cable. Commonly used in the marine industry.

Black		
28-202R4 gauge.....	P.O.R. /ft
28-203R2 gauge.....	P.O.R. /ft
28-204R1/0 gauge.....	P.O.R. /ft
28-205R2/0 gauge.....	P.O.R. /ft
Red		
28-208R4 gauge.....	P.O.R. /ft
28-209R2 gauge.....	P.O.R. /ft
28-210R1/0 gauge.....	P.O.R. /ft
28-211R2/0 gauge.....	P.O.R. /ft



LEAD MARINE BATTERY TERMINALS

Heavy duty terminals with wing nut for easy installation.
28-026R9.95 /pr



BRONZE MARINE BATTERY TERMINALS

Heavy duty terminals with wing nut for easy installation.
28-029R13.95 /pr

BLUESEA



BATTERY TERMINAL INSULATOR

Suitable for top-mount, dual-post marine batteries. Meets requirements of ABYC Small Craft Section E-9, USCG 33 Subpart I, and ISO 10133 for preventing accidental grounding of battery terminals. Secure with cable tie (cable tie not included). Suitable for use in environments up to 105°C. Includes one black and one red insulator.
28-533R8.55



HEAVY DUTY LUGS

Tinned electrolytic copper.

28-680R8 Ga. x #10.....	0.99
28-681R8 Ga. x 1/4".....	0.99
28-682R8 Ga. x 5/16".....	0.99
28-683R8 Ga. x 3/8".....	0.99
28-684R8 Ga. x 1/2".....	0.99
28-685R6 Ga. x 1/4".....	1.15
28-686R6 Ga. x 5/16".....	1.15
28-687R6 Ga. x 3/8".....	1.15
28-688R6 Ga. x 1/2".....	1.25
28-690R4 Ga. x 5/16".....	1.25
28-691R4 Ga. x 3/8".....	1.25
28-692R4 Ga. x 1/2".....	1.49
28-694R2 Ga. x 5/16".....	1.59
28-695R2 Ga. x 3/8".....	1.59
28-696R2 Ga. x 1/2".....	1.85
28-697R1/0 Ga. x 5/16".....	2.25
28-698R1/0 Ga. x 3/8".....	2.25
28-699R1/0 Ga. x 1/2".....	2.25
28-700R2/0 Ga. x 5/16".....	3.20
28-701R2/0 Ga. x 3/8".....	3.20
28-702R2/0 Ga. x 1/2".....	3.20
28-704R3/0 Ga. x 3/8".....	3.95
28-705R3/0 Ga. x 1/2".....	3.95
28-707R4/0 Ga. x 3/8".....	5.20
28-708R4/0 Ga. x 1/2".....	5.65



BATTERY TERMINAL CLEANING TOOL

Plastic & Steel Nickel Plated.
28-131R8.95



3M ELECTRIC TAPE

7 mils thick, tough and stretchy. Each roll cellophane wrapped. U.L. listed. 3/4" x 60 ft.

56-032PBlack.....	2.49
56-035RBlue.....	2.69
56-036RGreen.....	2.69
56-037ROrange.....	2.69
56-038RRed.....	2.69
56-039RWhite.....	2.69
56-041RYellow.....	2.69

PICO



AGC FUSES

1/4" x 1 1/4". Rated up to 32VDC.

28-080R1A.....	0.69
28-294R2A.....	0.69
28-081R3A.....	0.69
28-082R5A.....	0.69
28-083R7.5A.....	0.69
28-084R10A.....	0.69
28-085R15A.....	0.69
28-086R20A.....	0.69
28-236R25A.....	0.69
28-237R30A.....	0.69

PICO



ATC FUSES

28-556R3A.....	0.45
28-557R5A.....	0.45
28-558R10A.....	0.45
28-559R15A.....	0.45
28-560R20A.....	0.45
28-561R25A.....	0.45
28-562R30A.....	0.45



FUSE HOLDER

28-087RAGC - Glass.....	0.89
28-052RATC - Spade.....	2.09



FUSE HOLDERS WITH "LED"

28-094RAGC - Glass.....	9.95
---------	-----------------------	------



CENTAUR CHARGERS

Three isolated outputs simultaneously charge three battery banks at the full rated current. Provides three stage charging with internal temperature compensation. All models will operate without any adjustment over a universal 90–265 VAC, 45–65 Hz input voltage range. Aluminum epoxy powder coated cases with drip shields and stainless steel fittings withstand the rigors of heat, humidity and salt air. Circuit boards are protected with an acrylic coating for maximum corrosion resistance. A dip switch selects the optimum charge/float voltages for flooded lead-acid, gel or AGM batteries.

Model 12/20

12 VDC, 20 Amp continuous output. Recommended for batteries from 80 to 200 Ah capacity.

Dimensions: 14"H x 8.5"W x 4.3"D

28-1050A.....558.00

Model 12/30

12 VDC, 30 Amp continuous output. Recommended for batteries from 120 to 300 Ah capacity.

Dimensions: 14"H x 8.5"W x 4.3"D

28-1051A.....619.00

Model 12/40

12 VDC, 40 Amp continuous output. Recommended for batteries from 160 to 400 Ah capacity.

Dimensions: 16.8"H x 9.4"W x 5.3"D

28-1052A.....759.00

Model 12/60

12 VDC, 60 Amp continuous output. Recommended for batteries from 240 to 600 Ah capacity.

Dimensions: 16.8"H x 9.4"W x 5.9"D

28-1053A.....820.00

Model 12/80

12 VDC, 80 Amp continuous output. Recommended for batteries from 320 to 800 Ah capacity.

Dimensions: 19.9"H x 10"W x 5.2"D

28-1054A1360.00

Model 12/100

12 VDC, 100 Amp continuous output. Recommended for batteries from 400 to 1000 Ah capacity.

Dimensions: 19.9"H x 10"W x 5.2"D

28-1055A1665.00

Model 24/30

24 VDC, 30 Amp continuous output. Recommended for batteries from 120 to 300 Ah capacity.

Dimensions: 16.8"H x 9.4"W x 5.3"D

28-1056A.....959.00

Model 24/40

24 VDC, 40 Amp continuous output. Recommended for batteries from 160 to 400 Ah capacity.

Dimensions: 19.9"H x 10"W x 5.2"D

28-1057A1250.00

Model 24/60

24 VDC, 60 Amp continuous output. Recommended for batteries from 240 to 600 Ah capacity.

Dimensions: 19.9"H x 10"W x 5.2"D

28-1058A1430.00

"CHARGE PRO" BATTERY CHARGERS

Microprocessor and software control for precision, fully automatic 5-stage performance charging. Dedicated battery charging, sensing and control per bank. Expanded LED charge status monitor. Wiring and battery fault detection. 100% waterproof (IP67) and shock resistant for all fresh and saltwater applications. Built-in safety: reverse polarity, over-current, over-voltage, over-temp, and ignition protection. In-line fuses for maximum DC wire protection.



Model 2708A

28-740P.....12V - 5 Amp - 1 Bank159.00

Model 2710A

28-742P.....12V - 10 Amp - 1 Bank234.00

Model 2711A

28-743P12/24V - 10 Amp - 2 Bank.....251.00

Model 2713A

28-744P12/24V - 15 Amp - 3 Bank.....306.00

Model 2720A

28-745P12/24V - 20 Amp - 2 Bank.....325.00

Model 2731A

28-746P12/24V - 30 Amp - 3 Bank.....589.00

Model 2740A

28-747P12/24V - 40 Amp - 4 Bank.....735.00



BATTERY MAINTAINER

Charge batteries 1.2 Ah to 40 Ah, maintain batteries 1.2 Ah to 125 Ah. Energy savings mode automatically shuts off the charger when the battery is charged, then periodically monitors the battery and turns back on when the battery falls below 12.9 V. Maintainer can safely stay connected to the battery for long periods of time. LED's let you know when the power is ON, battery is being charged, and when charging is complete.

28-750P58.95



BATTERY MAINTAINER

Provides 0.75 AMP charging, ideal for seasonal vehicles. Auto shut-off. Short circuit protected. Input 120 VAC output 0.75 AMP. Suitable for lead acid, wet maintenance free and gel batteries. Supplied with alligator clips, ring terminal and quick connect fittings.

28-028M.....28.95



Mini OLED Digital Monitors

Monitors essential electrical system parameters on a bright, waterproof, daylight readable OLED screen

- Compact size enables mounting in any convenient location.
- Reverse polarity protected
- Mounts in a common 1-1/8 in hole



DC Ampmeter (Model 1732)

- Convenient amperage monitoring
- Monitors -100A to 100A DC
- Positive or negative side wiring
- Includes Shunt

28-503P139.95



Temperature Monitor (Model 1741)

- Convenient temperature monitoring
- Temperatures range from -40°C to 125°C
- Measures in Fahrenheit or Celsius
- Includes Sender

28-504P106.95



DC Voltmeter (Model 1733)

- Monitors DC voltage on a bright, waterproof, daylight readable OLED screen.

28-505P76.95



VICTRON INVERTER/CHARGERS

Phoenix Multiplus

MultiPlus is a powerful true sine wave inverter, a sophisticated battery charger that features adaptive charge technology and a high-speed AC transfer switch in a single compact enclosure.

Multiplus 12/2000/80

Input 9.5–17 VDC; output 120 VAC, 60 Hz. Continuous output power 1,600 W, peak power 4,100 W. Battery charge current 80 Amp, starter battery charge current 4 Amp. Battery connection M8 studs.

Dimensions: 20.5”H x 10”W x 4.9”D

28-1065A1660.00

Multiplus 12/3000/120

Input 9.5–17 VDC; output 120 VAC, 60 Hz. Continuous output power 2,000 W; peak power 4500 W. Battery charge current 120 Amp, starter battery charge current 4 Amp. Battery connection M8 studs, 120 VAC connection 6-ga. screw clamp.

Dimensions: 19”H x 10.2”W x 8.6”D

28-1066A1985.00

Multiplus 24/2000/50

Input 19–33 VDC; output 120 VAC, 60 Hz. Continuous output power 1,600 W, peak power 4,100 W. Battery charge current 50 Amp, starter battery charge current 4 Amp. Battery connection M8 studs.

Dimensions: 20.5”H x 10”W x 4.9”D

28-1068A1699.00

Multiplus 24/3000/70

Input 19–33 VDC; output 120 VAC, 60 Hz. Continuous output power 2500 W, peak power 6000 W. Battery charge current 70 Amp, starter battery charge current 4 Amp. Battery connection M8 studs, 120 VAC connection 6 ga. screw clamp

Dimensions: 19”H x 10.2”W x 8.6”D

28-1069A1985.00



PHOENIX MULTI CONTROL

Remote control and monitoring for Multi and Quattro models, ON/OFF inverter control and power control. Set maximum generator or shore power current draw from 0–30 Amps; the Multi uses remaining AC loads for battery charging, preventing the generator or shore power from being overloaded. Connection requires standard UTP cable, sold separately.

28-1071A30 Amp220.00

28-1072A15m UTP Cable34.00



12 VOLT DEEP CYCLE BATTERIES

Batteries designed to withstand repetitive discharge. Good for running accessories and starting.

G24DC, 550CCA, 140RC, 18 MTH
 SIZE: 11.2"L X 6.7"W X 9.7"H, WEIGHT: 41 LBS
 28-614K.....186.00

G27DC, 675CCA, 180RC, 18 MTH
 SIZE: 12.8"L X 6.7"W X 9.8"H, WEIGHT: 52 LBS
 28-615K.....209.00

G31DC, 675CCA, 210RC, 18 MTH
 SIZE: 13"L X 6.7"W X 9.8"H, WEIGHT: 61 LBS
 28-616K.....262.00



12 VOLT COMMERCIAL BATTERIES

Heavy Duty Commercial batteries designed for starting big engines and running accessories.

GA8D, 1400CCA, 450RC, 18MTH
 SIZE: 20.6"L X 11.2"W X 9.5"H, WEIGHT: 130 LBS
 28-620K.....465.00



12 VOLT MAINTENANCE FREE BATTERY

100% maintenance free, provides superior sustained performance. Eliminates acid build up that prematurely destroys battery capacity and life. Increases material utilization providing superior sustained performance and increased life.

EFB8D, 1500CCA, 475RC, 36MTH
 SIZE: 20.7"L X 11.1"W X 9.8"H, WEIGHT: 132 LBS
 28-624K.....735.00



8 VOLT COMMERCIAL BATTERIES

Heavy Duty Commercial batteries designed for starting big engines and running accessories.

S-821, 800CCA, 470RC, 12MTH
 SIZE: 21.1"L X 7.5"W X 11.0"H, WEIGHT: 112 LBS
 28-605J675.00

S-827, 900CCA, 500RC, 12MTH
 SIZE: 27.6"L X 7.6"W X 11.0"H, WEIGHT: 141 LBS
 28-604J845.00



6 VOLT DEEP CYCLE BATTERIES

Designed for repetitive discharge. Good for running accessories, not designed for starting engines. Minimum 2 required for 12-volt applications.

US2200-UTL, 232AH, 474RC, 24MTH
 SIZE: 10.4"L X 7.1"W X 11.2"H, WEIGHT: 63 LBS
 28-625K.....339.00





BATTERY BOXES

Constructed of polypropylene. Acid resistant. Come with hold down strap and hardware.

Standard Box (For Series 24 Batteries)

28-141R.....11.13"L x 7.75"W x 10.13"H 17.95

Large Box (For Series 27 Batteries)

28-142R.....13.44"L x 7.25"W x 10.5"H 19.95

Replacement Battery Box Strap

28-143R..... 7.25

NEW



BATTERY TRAYS WITH STRAPS

Heavy duty battery tray includes tray, quick release buckle and strap.

For 24 Series Batteries

28-158P11.31"L x 7.25"W x 1.31"H13.50

For 27 Series Batteries

28-159P12.94"L x 7.25"W x 1.31"H13.95

NEW



BATTERY TRAYS WITH BRACKETS

Just the right battery accessory for long-life battery performance. Non-corrosive hi-strength plastic construction with self-locking security knobs. Fits all the new battery dimensions and with stainless steel hold down rods.

For 24 Series Batteries

28-161P12.88"L x 7.38"W x 9"H.....29.95

For 27 Series Batteries

28-162P14.38"L x 7.13"W x 10.5"H34.95

For 29-31 Series Batteries

28-163P15.50"L x 8"W x 10.5"H.....39.95



HEAVY DUTY BATTERY BOXES

Non-corrosive high-strength polyethylene construction resists chemicals and rust. Maintains tough properties with nominal 0.185" wall thickness on roto-molded (mixed linear-black) boxes. Complies to industry requirements and meets Coast Guard regulations.

4-D battery box

28-500P193.00

Inside Dia. 21"L x 9.75"W x 13.5"H

Outside Dia. 23.87"L x 12.5"W x 14"H

8-D battery box

28-501P219.00

Inside Dia. 21 3/8"L x 11 5/8"W x 13.5"H

Outside Dia. 24.37"L x 14.5"W x 14.12"H





BATTERY SELECTOR SWITCHES



BLUE SEA ADD A BATTERY

The Blue Sea 7650 Add a Battery package is a complete two battery bank management solution. It features a Blue Sea 5511e Dual Circuit Plus™ Battery Switch which isolates engine and house circuits and a Blue Sea 7610 120 Amp SI ACR automatic charging relay which combines batteries for charging.

28-539R.....(Model #7650)269.95

BATTERY SWITCH, DUAL CIRCUIT PLUS

Simultaneously switches two isolated battery banks or combines battery banks to all loads. Make-before-break contact design allows switching between battery banks without power interruption. Ignition protected—safe for installation aboard gasoline powered boats. Case design allows surface or rear panel mounting. Meets American Boat and Yacht Council (ABYC) requirements for battery switches.

28-537R.....(Model #5511e)98.50



28-146

28-235

BATTERY SWITCHES

Heavy-Duty Selector Switch

Our best switch from Perko. Features: 380 amps continuous, 850 intermittent, fiber reinforced polycarbonate body. 1/2" Dia. brass terminals. For systems 6 to 32 volts.

28-146R.....Model 8603.....333.50

Medium-Duty Selector Switch

Economical battery disconnect switch from Perko. 250A continuous, 360 intermittent. For use with systems up to 32V.

28-235R.....Model 8501.....104.05



28-507



2 POSITION E-SERIES BATTERY SWITCH

Switches a single battery to a single load group. Ignition protected—safe for installation aboard gasoline powered boats. Case design allows surface or rear panel mounting.

28-506P.....(Model #9003e)68.50



28-508

HIGH PERFORMANCE BATTERY SWITCHES

Vapour proof and ignition protected for installation in gas or diesel engines. Rated 350 Amps continuous and 600 Amps intermittent. Maximum 32 VDC. Accepts up to 4/0 battery cable on 3/8" tin plated copper studs. Can be surface mounted. Comes with Alternator Field Disconnect to protect the alternator in the event that the switch is turned off while the engine is running.

28-507P .Battery Selector - AFD(Model9002E)...79.95

Great value in a top quality switch for single battery installations. Same ratings as switch above and comes with Alternator Field Disconnect.

28-508P...On/Off Switch - AFD(Model 9004E) ...95.95

BATTERY DISCONNECT SWITCHES



28-213

28-214

BATTERY DISCONNECT SWITCHES

Heavy-Duty Model 9703 (on / off)

Our best selling heavy-duty battery disconnect. Rated at 450 amps continuous, 1200 intermittent. (Systems to 32V).

28-213R.....Model 9703DP317.35

Medium-Duty Model 9601 (on / off)

250 amps continuous, 360 intermittent. For use with systems up to 32V.

28-214R.....Model 9601DP100.15



MINI ON/OFF BATTERY SWITCH

Switches a single battery to a single load group. Ignition protected—safe for installation aboard gasoline powered boats. Case design allows surface, front panel, or rear panel mounting. Isolating cover with snap-on sections protects rear contacts. Rated 300 Amps continuous and 500 Amps intermittent. Maximum 48 VDC. Accepts up to 4/0 battery cable on 3/8" tin plated copper studs.

28-509P.....Model 6006.....45.95



"LED" CORDSET

The PowerCord PLUS® has features you won't find on other cordsets. "LED" Power Indicator Light. Contour Grip Ends. Includes threaded ring and Easy Lock ring. Thumbprint Locator. Super Flexible 10/3 Cable. Easy Lock System. Includes the Marinco Easy Lock™ System Ring - A simple 1/8 twist provides a fast, positive watertight connection

Model 50SPP

28-875P.....50' 30 Amp, 125 Volt.....174.95

Model 25SPP

28-878P.....25' 30 Amp, 125 Volt.....154.95



50' "LED" CORDSET

- Watertight molded plug and connector ends for safety and durability.
- Heavy-duty, super flexible marine grade cable (30 Amp 10 gauge).
- Corrosion-resistant, nickel-plated contacts.
- ULus approval.
- 5-year warranty.
- Patented Jaw Clamp technology.
- No threaded ring required.
- Create a watertight seal every time.
- Proprietary built-in cord light.
- Added safety alert light indicates if you are still plugged in at the dock.
- Emergency flashlight to lead your way back to the dock
- Power Indicator Light on both ends Informs you that power is flowing through the cord.
- Secondary lock for added security.
- When engaged, the wings cannot be unclamped.
- Universal Connection•Connects to any brand, NEMA configured inlet.

Model CS30-50

28-1149P.....50' 30 Amp, 125 Volt.....214.90



MARINCO CORD HOLDER

28-874P.....Pk. of 6.....25.95



NEMA LS-30R 30A 125V Locking

EASY-LOCK POWER INLET - 30A / 125V

Glass-Filled polyester construction. No thread corrosion. Cap holds open for easy insertion of power cable. Exceeds ABYC watertight requirements. Corrosion proof, watertight. Lock threads secure cord.

Model 301EL-B

28-880P.....30 Amp, 125 Volt.....94.75



NEMA SS-1 50 AMP 125V Locking

STAINLESS STEEL POWER INLET - 50A / 125V

Solid cast 316 stainless steel. Locking waterproof cap. Easy Lock System. Soft Touch cap stays open in the upright position. 8-way right angle rear safety enclosure.

Model - 6371EL-B

50 amp / 125 volt
28-883P.....267.00



NEMA SS-2 50A 125/250V Locking

STAINLESS STEEL POWER INLET-50A / 125/250V

Solid cast 316 stainless steel. Locking waterproof cap. Easy Lock System. Soft Touch cap stays open in the upright position. Rear safety enclosure with strain relief.

Model - 6373EL-B

50 amp / 125/250 volt
28-884P.....281.00



PHONE/TV INLET

Glass-filled polyester construction. Stainless steel trim on watertight cap. For Telephone and Cable TV connections.

MODEL - PH6574TV

28-885P.....106.50



NEMA LS-30R 30A 125V Locking

STAINLESS STEEL POWER INLET - 30A / 125V

Solid cast 316 stainless steel. Locking waterproof cap. Easy Lock System. Soft Touch cap stays open in the upright position. 8-way right angle rear safety enclosure.

Model - 303SSEL-B

30 Amp/125Volt
28-882P.....147.95



NEMA SS-2 50A 125/250V Locking

STANDARD POWER INLET - 50A / 125/250V

High strength plastic face & cap. No thread corrosion. Cap holds open for easy insertion of power cable. Exceeds ABYC watertight requirements. Corrosion proof, watertight. Lock threads secure cord.

Model 6353EL-B

50 Amp, 125 / 250 Volt
28-881P.....152.50



ON-BOARD CHARGER INLET

This on-board charger inlet, wired to your battery charger, allows charging without leaving hatches or doors unlocked. Flip lid cover and plug. Straight blade inlet, 15A - 125V. Low profile cap, easily mounts to wood, fiberglass or aluminum hulls. Color coded terminals. UV resistant.

Model 150BBI

28-943P.....15Amp, 125 Volt.....31.95



STAINLESS STEEL PHONE/TV INLET

316 Stainless Steel. Locking water proof cap. Soft touch cap design allows cap to remain in the up-right position during hook up. Water tight rear boot. For Telephone and Cable TV connections.

MODEL - PH6592TV-SS

28-886P.....141.65

MARINCO SHORE POWER SYSTEMS



"LED" Model

DOCK SIDE
MALE PLUG
Attaches to dockside receptacle or cordset

15A 125V
Straight Blade
w/ Locking Screw

BOAT SIDE
FEMALE CONNECTOR
Attaches to boat inlet or cordset

30A 125V
Locking w/ Sealing
Collar System



"LED" Model

DOCK SIDE
MALE PLUG
Attaches to dockside receptacle or cordset

30A 125V
Locking

BOAT SIDE
FEMALE CONNECTOR
Attaches to boat inlet or cordset

15A 125V
Straight Blade



DOCK SIDE
MALE PLUG
Attaches to dockside receptacle or cordset

30A 125V
Locking

BOAT SIDE
FEMALE CONNECTOR
Attaches to boat inlet or cordset

30A 125V
Locking w/ Sealing
Collar System

30A 125V
Locking w/ Sealing
Collar System

"LED" PIG TAIL ADAPTER-30A F/M TO 15A MALE
Model 104SPP
28-896P85.95

"LED" PIGTAIL ADAPTER-15A F/M TO 30A MALE
Model 105SPP
28-894P94.95

MARINCO Y-ADAPTOR 30A/125V
Model 157AY
28-899P324.00



BOAT SIDE
FEMALE CONNECTOR
Attaches to boat inlet or cordset

30A 125V
Locking w/ Sealing
Collar System

DOCK SIDE
MALE PLUG
Attaches to dockside receptacle or cordset

50A 125V
Locking

PIGTAIL ADAPTER-30A F/M TO 50A M 125V
Model 110A
28-897P215.00



BOAT SIDE
FEMALE CONNECTOR
Attaches to boat inlet or cordset

30A 125V
Locking w/ Sealing
Collar System

DOCK SIDE
MALE PLUG
Attaches to dockside receptacle or cordset

50A 125/250V
Locking

PIGTAIL ADAPTER-30A F/M TO 50A M 125/250V
Model 121A
28-902P217.00



BOAT SIDE
FEMALE CONNECTOR
Attaches to boat inlet or cordset

30A 125V
Locking w/ Sealing
Collar System

DOCK SIDE
MALE PLUG
Attaches to dockside receptacle or cordset

30A 125V
Locking

RIGHT ANGLE ADAPTER WITH A 30A 125V
LOCKING W/ SEALING COLLAR FEMALE
CONNECTOR AND A 30A 125V LOCKING
MALE PLUG
Model 1RPC
28-946P71.95



DOCK SIDE
MALE PLUG
Attaches to dockside receptacle or cordset

15A 125V
Straight Blade
w/ Locking Screw

BOAT SIDE
FEMALE CONNECTOR
Attaches to boat inlet or cordset

50A 125V
Locking w/ Sealing
Collar System

PIGTAIL ADAPTOR-50 FEMALE TO 15 MALE
Model 115A
28-903P349.00



DOCK SIDE
MALE PLUG
Attaches to dockside receptacle or cordset

30A 125V
Locking

BOAT SIDE
FEMALE CONNECTOR
Attaches to boat inlet or cordset

50A 125/250V
Locking w/ Sealing
Collar System

PIGTAIL ADAPTOR-50A FEMALE TO 30A MALE
Model 117A
28-904P299.00



DOCK SIDE
MALE PLUG
Attaches to dockside receptacle or cordset

30A 125V
Locking

BOAT SIDE
FEMALE CONNECTOR
Attaches to boat inlet or cordset

50A 125V
Locking w/ Sealing
Collar System

PIGTAIL ADAPTOR-50A FEMALE TO 30A MALE
Model 111A
28-901P276.00



FEMALE LOCKING CONNECTOR
Model 4731CR.....15Amp, 125Volt

28-934P47.50



MALE LOCKING PLUG
Model 4721CR.....15Amp, 125Volt

28-933P28.50



MALE LOCKING PLUG
Model 205CRPN.....20Amp, 125Volt

28-914P33.95



FEMALE LOCKING CONNECTOR
Female locking connector. Requires cover below for weatherproof seal (103ELN).
Model 305CRCN.....30 AMP, 125 VOLT

28-928P49.95



MALE LOCKING PLUG
Male locking plug. Requires cover for weather proof seal (Model 102N), available below.
Model 305CRPN.....30Amp, 125Volt

28-924P27.95



"STRAIGHT BLADE" FEMALE CONNECTOR
Model 5269CR.....15Amp, 125Volt

28-916P44.95



CONNECTOR COVER
Weatherproof cover with Easy-Lock threaded ring. Fits Model 305CRCN above.
Model 103ELN

28-930P30.95



CONNECTOR COVER
Weatherproof cover fits Model 305CRPN & 205CRPN Model 102N

28-926P18.50



"STRAIGHT BLADE" MALE PLUG
Model 5266CR.....15Amp, 125Volt

28-915P48.95



FEMALE LOCKING CONNECTOR
Female locking connector. Requires cover below for weather-tight seal. (Model 7715CRN)
Model 6364CRN.....50 AMP, 125/250 VOLT

28-929P152.95



MALE LOCKING PLUG
Requires cover for weather proof seal (model 7717N), available below.
Model 6365CRN.....50Amp, 125/250Volt

28-925P136.95



SEALING COLLAR WITH THREADED RING
Provides maximum moisture protection between cordset and adapter
For use with 20A and 30A locking systems
28-937P.....Model 110R18.95
Use with 50A locking systems.
28-940P.....Model 510R21.95

Threaded Ring Easy-Lock Ring



CONNECTOR COVER
Weatherproof cover with Easy-Lock threaded ring. Fits Model 6364CRN above.
Model 7715CRN

28-931P44.50



CONNECTOR COVER
Weatherproof cover fits Model 6365CRN above.
Model 7717N

28-927P32.95

THREADED & EASY-LOCK RINGS
Model 100R - Threaded
28-938PFor use with 30A systems11.50
Model 500R - Threaded
28-941PFor use with 50A systems12.95
Model 100EL - Easy-Lock
28-939PFor use with 30A Inlets11.95
Model 500EL - Easy-Lock
28-942PFor use with 50A Inlets14.50

SHORE POWER SYSTEMS

These adapters do not have covers and are not recommended for use in wet locations.



BOAT SIDE
FEMALE CONNECTOR
 Attaches to boat inlet or cordset

DOCK SIDE
MALE PLUG
 Attaches to dockside receptacle or cordset

15 or 20A 125V
 Straight Blade



20A 125V
 Locking

STRAIGHT ADAPTOR

Model S20-15
 15/20 Amp FEMALE TO 20 Amp MALE

28-1150P.....83.95



BOAT SIDE
FEMALE CONNECTOR
 Attaches to boat inlet or cordset

DOCK SIDE
MALE PLUG
 Attaches to dockside receptacle or cordset

30A 125V
 Locking



15A 125V
 Straight Blade

STRAIGHT ADAPTOR

Model S15-30
 30 Amp FEMALE TO 15 Amp MALE

28-1153P.....68.95



BOAT SIDE
FEMALE CONNECTOR
 Attaches to boat inlet or cordset

DOCK SIDE
MALE PLUG
 Attaches to dockside receptacle or cordset

15 or 20A 125V
 Straight Blade



30A 125V
 Locking

STRAIGHT ADAPTOR

Model S30-15
 15/20 Amp FEMALE TO 30Amp MALE

28-1151P.....68.95



DOCK SIDE
MALE PLUG
 Attaches to dockside receptacle or cordset

BOAT SIDE
FEMALE CONNECTOR
 Attaches to boat inlet or cordset

20A 125V
 Locking



30A 125V
 Locking

STRAIGHT ADAPTOR

Model S20-30
 30 Amp FEMALE TO 20 Amp MALE

28-1154P.....114.95



- Always Open
- Sale & Feature items
- View Catalogue
- Thousands of products
- Updated regularly
- Up to date pricing
- Mobile friendly
- Shop from anywhere at anytime

www.mercersmarine.com

Also find us on





ONGARO HORNS

Premium Stainless Steel Horns

These Ongaro horns have all stainless steel parts inside and out. The sounds are pre-wired and completely sealed, they have extreme sound levels that quiet the competition. 124 db.

- 28-576P16.5" Single, 12V164.95
- 28-577P16.5" Single, 24V179.95
- 28-579P18.5" Double, 12V329.95
- 28-580P18.5" Double, 24V349.95



ERTIZORNE

PORTABLE HORN

100% ozone friendly signal horn, meets USSG recommendations. Can be heard up to 1/2 mile away. Flammable propellant.

- 50-032RComplete19.95
- 50-033RRepl. refill11.95



PERKO

PERKO MOUTH OPERATED FOG HORN

- 50-036RWhite, Aluminum 12 1/2" O.L.....41.95



MOUTH OPERATED FOG HORN

- 50-037RStainless Steel 7 1/2" O.L.....34.95



AFI

DUAL TRUMPET AIR HORNS

Non-corrosive Lexan diaphragm. Includes compressor, air tubing, fittings and hardware. Dimensions are 17" L x 7" W x 3 3/4" H. Maximum amp draw: 12 Volt: 20 Amps, 24 Volt: 10 Amps. dB rating: 121 at one meter, 1/3 octave band. Fundamental frequency: 375 +- 15/315+-15. Chrome plated brass construction.

- 28-379M12V475.00
- 28-380M24V475.00



DROP IN HORNS

Stainless steel mini drop-in horn conceals the horn by just the flush mount grill being exposed. All stainless steel inside and out and grill is waterproof. 111db

Single Horn

- 28-585P12V71.95

Double Horn

- 28-584P12V137.95



AM

ECONOMY TRUMPET HORNS

- S.S. single, 15 3/4" x 4" x 5". Max. 10A at 12VDC
- 28-572R.....Single, 12V79.95

- S.S. dual, 18 1/4" x 4" x 5". Max. 10A at 12VDC
- 28-573R.....Double, 12V159.95



ONGARO COMPACT HORN

A sleek compact horn from Ongaro designed for the smaller pleasure craft. Stainless steel bracket and cover. 108 db.

- 28-582P12V51.95



ONGARO COMPACT HORN DUAL

All stainless steel horn. Inside and Out. NO RUST. Horn is prewired and sealed. Meets ABYC standards for boats up to 65 feet.

3"L x 8"W x 1-3/4"H.

- 28-583P12V139.95



MINI-HORN DUAL

All stainless steel horn. Inside and Out. White Powder Coated. NO RUST. Horn is prewired and sealed. Meets ABYC standards for boats up to 65 feet.

3"L x 8"W x 1-3/4"H.

- 28-570P12V79.95



WINDSHIELD SUPPORT BAR

Used as original equipment on many windshields, windshield support bars are made from powder coat aluminum tubing with chrome plated zamak feet.

The fittings allow for pivot in almost every direction for easy installation. **Sold in single units.**

- 46-061K.....16"79.95



ONGARO WATERPROOF WIPER MOTORS

316 Stainless Steel - Rigid Aluminum Housing - Adjustable Sweep angle 40 - 110 degrees. Adjustable park position Right or Left - 2 speeds - will power up to 24 inch arm and blade combination.

- 28-638P12v - 2.5" shaft.....195.00
- 28-639P12v - 3.5" shaft199.00
- 28-640P24v - 2.5" shaft204.00
- 28-641P24v - 3.5" shaft208.00



ONGARO WIPER ARMS & BLADES

Straight Arm & Blades

- 28-651P12" to 18" adjustable arm55.95
- 28-663P.....12" wiper blade19.95
- 28-664P.....14" wiper blade21.95
- 28-665P16" wiper blade22.95
- 28-666P18" wiper blade23.50



Pantographic Arm & Blade

- 28-654P14" to 19" adjustable arm126.95
- 28-663P.....12" wiper blade19.95
- 28-664P14" wiper blade21.95
- 28-665P16" wiper blade22.95
- 28-666P18" wiper blade23.50



LUBASE WIPER MOTORS

A good quality, 2 speed, low priced motor. This motor is set at 110 degrees but has an adjustable sweep that allows the motor to be reset at 45, 60, or 80 degrees. Motor is preset for right angle drive and can be changed to left angle drive. Self parking.

- 28-765R12v. - 1 1/2" shaft.....185.00
- 28-766R12v. - 2 1/2" shaft.....185.00
- 28-767R12v - 3 1/2" shaft.....189.00
- 28-769R24v. - 2 1/2" shaft.....185.00
- 28-770R.....24v - 3 1/2" shaft189.00



BOSCH HEAVY DUTY WIPER BLADES

- 28-658P16" straight wiper blade26.95



- 28-648P 16" pantographic wiper arm89.95
- 28-660P 16" flex wiper blade24.95



ECONOMY MARINE WIPER MOTOR

A light duty wiper motor designed for sport boats.

- 28-110R2 1/2" Shaft79.95
- 11" Wiper Arm
- 28-113R.....11"13.95
- 14" Wiper Blade
- 28-114R14"4.95



3 POSITION WIPER SWITCH

This marine switch is suitable for 2-speed, self parking motors. Will operate 12v or 24v ongaro wiper motors.

- 28-635P36.95



ONGARO STANDARD WATERPROOF WIPER KIT

Contains one standard waterproof motor. One 14" wiper blade. One 11"-14" adjustable arm. Features: 12 volt motor. 80 or 110 degree sweep angle. Self park-Left or Right. Insulated Grounding.

- 28-632P179.95
- 28-633P14" Arm39.95
- 28-664P14" Blade21.95



CLEARVIEW SCREENS

The 12" diameter screen rotates at 1900 RPMs to keep water away. A 170 watt heater melts ice and snow. This unit may be installed in window thicknesses from 8mm to 16mm. A 324mm diameter window cut out.

- 28-338A12V1495.00
- 28-339A24V1495.00
- 28-341A110V1495.00

Replacement Parts

- 28-342A12V Motor.....375.00
- 28-343A24V Motor.....375.00
- 28-345A110V Motor.....375.00
- 28-346AMotor Brushes.....14.25/ pr.

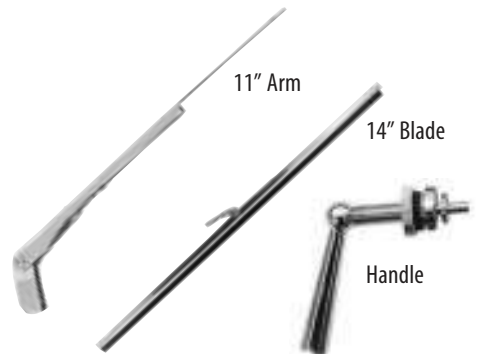

HAND WINDSHIELD WIPER ASSEMBLY

Stainless steel construction. Complete assembly requires all 3 parts listed below.

- 28-113R11" Arm13.95
- 28-114R.....14" Blade4.95
- 28-115R.....Handle Assembly22.95

Castramo



SIROCCO II FAN

The Sirocco II 12/24 Volt fan features a unique gimbaled design that allows airflow to be directed in any direction of the cabin - 360°. The Sirocco can also be folded flat and out of the way against the bulkhead when not in use. Multiple speeds, timer settings and quiet operation.

28-1018R12/24 Volt.....159.95

Castramo



BORA FAN

The model 748 Bora fan solves any on-board airflow challenge. The fan is ideal for clearing a bridge windshield, venting a galley or providing cool comfort in the sleeping berth. This versatility has made the Bora our most popular selling fan. Three speed touch control Compact design. Mounts sideways, upright or downwards.

28-1022R.....12 Volt102.95

Castramo



KONA FAN

The model 817 Kona fan is designed for the most demanding marine conditions. Featuring a watertight motor and constructed of extruded aluminum, UV stabilized plastic and stainless fasteners the Kona is ideal for environments such as the wheelhouse dash or an exposed bridge or cockpit where splash and spray would spell disaster for other fans. The variable speed motor allows for a multitude of settings. The standard lighter plug adapter and suction cup mount option allow this fan to be moved wherever it is needed on the boat - above or below the deck.

28-1016R.....12 Volt229.95

rule



IN-LINE BLOWERS

Designed for efficient, high output operation, these blowers feature front and rear shaft seals and corrosion resistant motor housing. 5 1/4" long. Ignition protected.

3" inlet and outlet, 135 CFM air flow, 2.9 amp draw.
(use 4 amp fuse.)

28-349P12VDC.....66.95

4" inlet and outlet, 235 CFM air flow, 4.3 amp draw.
(use 7 amp fuse.)

28-350P12VDC.....72.95

3" inlet and outlet, 135 CFM air flow, 2.9 amp draw.
(use 4 amp fuse.)

28-597P24VDC.....64.95

4" inlet and outlet, 235 CFM air flow, 4.3 amp draw.
(use 7 amp fuse.)

28-598P24VDC.....78.95

W



12V OSCILLATING FAN

Economical oscillating fan used mainly for defogging or cooling wheel houses, cabins or galleys. Comes complete with mounting bracket. 12VDC.

28-098R.....6" Blade38.95

Castramo



Model 810
Gold Blade

Castramo



Model 812
Nickel Blade

ECOFAN

Ecofan circulates warm air throughout the room which increases the user's comfort. These fans are designed to sit on top of a freestanding wood or pellet stove. Ecofan generates its own electricity without cords or batteries. Ecofan starts automatically when placed on top of a stove and adjusts its speed with the stove temperature. As the stove heats up, Ecofan runs faster. As the stove burns down and cools, Ecofan automatically shuts off.

ECOFAN ULTRA AIR MODEL 810

- Air Flow : Up to 105 CFM
 - Temperature Range 212°F - 650°F (100°C – 345°C)
 - 3" x 5.5" x 9"
- 28-1032K.....(Gold Blade)129.95

ECOFAN AIRMAX MODEL 812

- Air Flow : Up to 150 CFM
 - Temperature Range 185°F - 650°F (85°C – 345°C)
 - 3.3" x 5.5" x 10"
- 28-1030K.....(Nickel Blade)174.95





4" JABSCO FLEXMOUNT BLOWER

4" inlet, 3 5/8" outlet. 250 CFM. Ignition protected. Extended Life 10,000 Hour Motor. Tough Reinforced Thermoset Plastic Housing. Mounts To Any Flat Surface. Slip-On Inlet Ducting Connection. Efficient High Volume Air Flow. Low-Current Draw. Corrosion-Resistant Materials Throughout. N.M.M.A. Type Accepted. Meets USCG Regulation 183.410 and ISO 8846 MARINE for Ignition Protection. Complies with ISO 9097 MARINE 9 5/8" H x 9 3/16" W x 9 1/4" L.

- 28-067M.....12 Volt (35770-0092)451.00
- 28-068M.....24 Volt (35770-0094)457.00



PALI ENGINE ROOM HEATER

Extend the boating season and protect your engine against surprise cold snaps prior to winterization. The Pali utilizes a self-regulating PTC heating element that cannot overheat. It meets all ignition protection guidelines and standards to allow it to be safely used in the marine engine compartment. It is the only heater of its type fully safety compliant to UL and CSA standards. Dimensions 9" L x 5" W x 4.8"H

- 28-1034P120 Volt VAC355.00



CAFRAMO HOT SPOT HEATER HEATER

A powerful space heater in a small package. The PTC ceramic heating element provides a constant source of heat but is cool to the touch and doesn't get hot enough to pose a fire hazard or burn risk. Comes with a built-in adjustable thermostat that allows you to maintain the perfect room temperature. Safety features include over-heat protection and automatic shut off if tipped over. Grounded plug for additional safety. 7.5" Long x 8" Width x 7.75" Height

- 28-1025R.....110 VAC64.95



TRUE NORTH DELUXE HEATER

This rugged AC electric heater keeps the cabin warm on the chilliest of those early and late season nights in the marina. ALCI safety plug option. Steel construction. 3 heat settings (600, 900 and 1500 Watt). Option of a 'fan only' setting. Thermostat controlled

- 28-1024R.....110 VAC142.95



STOR-DRY ELECTRIC HEATER

The Stor-Dry low wattage warm air circulator is the "must have" product for the winterization season. The model 9406 Stor-Dry combats mold, mildew and musty odors in any boat that is closed up or winterized. This dual action air dryer uses a low wattage heating element and internal fan to both heat and circulate the air. The heat and circulation prevents stale air pockets which in turn prevents mold or mildew forming on the interior surface of the boat.

- 28-1026R110 VAC x 90 Watts.....139.95



ROTO STYLE FAN/HEATER

Owners can defog their windshield in just minutes using the Model 9303 12 Volt defogger. Easy to install with either a sure grip suction cup or permanent screw down base and a standard lighter plug.

- 28-1010R.....12 Volt54.95



12V CERAMIC HEATER

Fan and heat, lightweight, easy to install. Adjustable 180 degree right to left. Provides steady, radiant and convection heat. Power cord 4m with in line 30 amp ATC fuse. 300 Watts.

- Dimensions 6.5"L x 4.25" W x 6"D
- 36-199P109.95



12V CERAMIC HEATER

Instant defrost for windshields. 360 degree swivel. Complete with a 54" cord and cigarette lighter adaptor plug. 150 watts.

- Dimensions 5" L x 4" W x 1.25"D
- 28-099P39.95



MERCER'S



BRASS PORTHOLE CLOCKS

Hi-polished brass, battery operated.

5 3/4" Base Diameter Model

60-030R.....219.95

9" Base Diameter Model

60-031R.....359.95



BRASS PORTHOLE TIDE CLOCK

Shows time of high and low tides. Hi-polished brass.

Battery operated.

60-009R.....5 3/4" dia. base.....319.95



BRASS PORTHOLE BAROMETERS

Hi-polished brass. A match for porthole clock.

5 3/4" Base Diameter Model

60-028R.....279.95

9" Base Diameter Model

60-029R.....399.95



BRASS CLOCK

We've sold this clock for years with excellent results. One of our best values. 4 1/2" Dia. base x 2 1/8"D.

Battery operated.

60-007RClock.....189.00



BRASS BAROMETER

We've sold this barometer for years with excellent results.

One of our best values. 4 1/2" Dia. base x 2 1/8"D.

Battery operated. A match for clock above.

60-008RBarometer.....239.00



4 IN 1 CLOCK COMBO

Combination Clock, Barometer, Hygrometer and Thermometer. 13" dia.

60-006R..... 399.00



SHIPS CLOCK

Lacquered brass with oak base plate. 8" Diameter.

60-032R..... 269.00



BRASS PORTHOLE MIRRORS

Attractive Porthole brass mirrors. Nautical appearance.

60-075P.....8".....79.95

60-045P.....12".....109.95

SHOP 24/7 FROM THE COMFORT OF YOUR OWN HOME

- Up to date Pricing
- New Products
- Stock Status
- Additional product info
- And more



www.mercersmarine.com

RITCHIE®

NAVIGATOR SERIES

Have the comfort of a large compass at an affordable price. 4 1/2" Power Damp Dial. Full Internal Gimbals with built in compensators. 45° lubber lines. 100% repairable. 12v night lighting.



NAVIGATOR MODEL DNP-200

Binnacle mount, polished stainless steel finish. See Specs above.

58-001M.....975.00

RITCHIE®



NAVIGATOR MODEL FN-201

Flush mount, black finish. See Specs above.

58-026M.....695.00

RITCHIE®



NAVIGATOR MODEL BN-202

Bulkhead mount, black finish. See Specs above.

58-002M.....725.00

RITCHIE®

HELMSMAN SERIES

Big compass features at a mid range price. One of the most popular series. 3 3/4" Power Damp Dial. 45° lubber lines with full Internal gimbals. Full compensation. Sapphire jeweled. 12v night lighting.



HELMSMAN MODEL HF-742

Flush mount, black finish. See Specs above.

58-059R.....475.00

RITCHIE®



HELMSMAN MODEL HB-740

Bracket mount, black finish. See Specs above.

58-051R.....479.00

RITCHIE®



HELMSMAN STEEL BOAT COMPASS MODEL HB-845

3 3/4" PowerDamp Dial. Special Reinforced Bracket with Quadrantal Correctors. Hardened Steel Pivot and Sapphire Jewel Movement. 45 Degree Lubber Lines.

Full Internal Gimbals. Exclusive Built-in Green NiteVu Lighting. Built-in Standard Compensators and Booster. Magnets on Base. Movable Sun Shield.

58-028M.....949.00

RITCHIE®

VOYAGER SERIES

The Voyager line of compasses is probably the most advanced compass of its size on the market. 3" Power Damp Dial with internal Gimbals. 12v Night Lighting and 45° Lubber lines. 100% repairable. Complete with sunshield.



VOYAGER MODEL S-87

Surface mount, black finish. See Specs above.

58-014R.....299.95

RITCHIE®



VOYAGER MODEL F-82

Flush mount, black or white finish. See Specs above.

58-004RBlack.....299.95

58-024R.....White.....299.95

RITCHIE®



VOYAGER MODEL B-80

Bracket mount, black finish. See Specs above.

58-006R.....319.95

RITCHIE
EXPLORER SERIES

Explorer is considered the perfect small boat compass. It has Ritchie quality and the small size to fit in those hard-to-fit places. 2 3/4" Direct Reading Dial with built in compensators. 12v Night Lighting. Directive Force Magnets. Complete with sunshield.



EXPLORER MODEL S-53

Surface mount, black finish. See Specs above.

58-013R.....149.95



EXPLORER MODEL F-50

Flush mount, black finish. See Specs above.

58-012R.....149.95



EXPLORER MODEL B-51

Bracket mount, black or white finish. See Specs above.

58-008RBlack.....149.95

58-010R.....White149.95



V-57.2 - EXPLORER (DASH MOUNT)

2 3/4" Direct Reading Dial. Fits 3" Instrument hole. Bezels Styled to Match Popular Gauge Packages. Viewing is adjustable to 30 degrees. Pivot Dial Movement. Exclusive Built-in NiteVu Lighting. Built-in Compensators to Easily Adjust for Deviation. Hi-Temperature Construction.

58-011R.....149.95

RITCHIE
RITCHIESPORT SERIES



X-21BB - RITCHIESPORT (DASH MOUNT)

2" Direct Reading Dial. Easily Installed, Fits Standard 2 1/16" Instrument Hole. View Adjusts up to 30 degrees. Pivot Dial Movement. Exclusive Built-in Green NiteVu Lighting. High Temperature Composite Construction for Extended Operating Range. Directive Force Magnets. Exclusive 5-Year Ritchie Warranty.

58-078R.....98.95



SPORT MODEL X-10M

Low profile, rugged, compact dash-mount compass. Sapphire jewel movement. Reversible bracket mount. Built-in compensators, self adhesive bracket mount pad. 1 7/8" direct read dial. Built-in night light. Grey finish.

58-009R.....77.95



RITCHIE CLINOMETER MODEL INC-45

Binnacle mount, black finish.

58-090R.....39.95



DORIS BOX COMPASS

Traditional compass designed for small craft. Comes in varnished wooden box with a sliding plexi-glass lid. The compass is gimbed. Card Diameter 2 3/4". Overall Dimension 6" x 6" x 4"H.

58-084M.....359.95

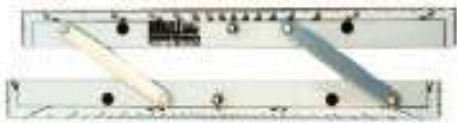

PARALLEL RULES

58-018R.....15" - Degrees38.95
 58-020R.....18" - Degrees46.95



DIVIDERS

7" interchangeable tips, nickel plated.

58-015R.....14.95

7" plain legged brass and stainless steel tips.

58-016R.....37.95



CHART HOLDERS

Heavy Duty. Watertight. It floats. High quality marine plastic with removable end.

58-023P.....36" x 3" dia.....41.95



RITE IN THE RAIN POCKET NOTEBOOKS

These are the truly go-anywhere, anytime, in any weather notebooks. The pocket notebooks are conveniently sized to take with you on your outings. With a Polydura cover and the Universal pattern, these 100 page (50 sheet) notebooks are perfect for any situation.



58-200M	3" x 5" Notebook	11.50
58-207M	3" x 5" Cordura Cover	45.95
58-201M	4" x 6" Notebook	14.95
58-208M	4" x 6" Cordura Cover	49.95
58-210M	4" x 6" Cordura Belt Case	44.95

All-Weather Standard Clicker Pen - Black Ink

While a pencil works great on our all-weather products, sometimes you just need a pen. These all-weather pens write on wet paper and upside down in temperatures from -30F to 250F. Chrome/Plastic barrel.

58-212M



LOG BOOK

Contains over 100 pages. Includes vessel data, voyage/trip log sheets, visitor log sheets, radio log, GPS waypoint index and fuel and repair sheets.

58-065M



JOURNAL MAXI-SPIRAL NOTEBOOK

If you're needing a large format notebook, look no further. The Maxi-Spiral Notebooks have strong Polydura covers, wire-o binding, and 84 pages (42 sheets).

58-206M



CLINOMETER

Bakelite construction with special dampening fluid to prevent over-reaction of the ball within the tube.

46-778R.....9.95

Bushnell



 WATERPROOF

BUSHNELL ENGAGE DX BINOCULARS

The Engage DX in the powerful 12X50 configuration are a perfect combination of performance, capability, and affordability with a lifetime warranty. They have an all-metal chassis, fully multicoated optics, and they have our exclusive EXO Barrier. Water is no problem as they're IPX7 waterproof rated to guarantee they'll never fog up. The rich textured rubber armor guarantees you'll always have a firm grip.

60-053M 12 X 50 429.99

Bushnell



 WATERPROOF

BUSHNELL ENGAGE REAL TREE BINOCULARS

The Engage X 10x42mm Binoculars deliver quality glass in a lightweight package. The fully multi-coated optics provide you with a brighter and clearer image at dusk and dawn when you need it most. These binoculars are IPX7 waterproof rated, and have Bushnell's exclusive molecularly bonded EXO Barrier for a clear image no matter the weather. An adjustable diopter ensures that these binoculars are fully adjustable to meet your eyes needs. The ultra-smooth focus wheel allows you to focus in on an object quickly for perfect definition.

60-056M 10 X 42 285.99

Bushnell



 WATERPROOF

BUSHNELL LEGEND BINOCULARS

The Legend is back, with an all-new design. Updated ergonomics give you a confident grip, with a lighter weight chassis than its predecessor. The all-glass, fully multi-coated optical system provides outstanding resolution, contrast, and light transmission. Combine that with an IPX-7 waterproof construction tested at 1 meter for 30 seconds and RainGuard HD protective coating, this binocular will stand up to the harshest of elements.

60-708M 10 X 50 285.99
60-710M 10 X 42 249.99

Binoculars

Bushnell



 WATERPROOF

BUSHNELL PRIME BINOCULARS

- Exclusive EXO Barrier Protection - Bushnell's newest and best protective lens coating molecularly bonds to the glass, repelling water, oil, dust, debris and preventing scratches.
- IPX7 Waterproof construction - O-ring sealed optics stay dry inside, when immersed in three feet of water for up to 30 minutes.
- Fully Multi-Coated Optics - Multiple layers of anti-reflective coating on all air-to-glass surfaces deliver bright, high-contrast images.

60-049M 10 X 25 134.99
60-050M 10 X 42 219.99
60-051M 12 X 50 266.99

Bushnell



 WATERPROOF

MARINE BINOCULAR

Features BaK-4 porro prisms for bright, clear, crisp viewing. Fully multi-coated optics. **These Marine series binoculars are buoyant, waterproof and corrosion resistant.** O-Ring sealed and nitrogen-purged to keep out moisture. Highly resistant to salt water corrosion. Non-slip, non-skid rubber armor cushions bumps and shock, prevents sliding and provides a firm grip when wet. Hermetically sealed. Fold down eye cups.

60-149M 7 x 50 278.99

Bushnell



 WATERPROOF

MARINE BINOCULARS / COMPASS

Built to withstand extreme nautical environments. **These Marine series binoculars are buoyant, waterproof and corrosion resistant.** Ultra-bright, crisp views granted by their multi-coated optics and premium BaK-4 prism glass. Rugged rubber armoring provides a sure grip, absorbs shock and keeps them from sliding in rough conditions. They're essential equipment if you spend much time on deck. Features: 7 x 50 magnification, internal range finder and compass.

60-036M 7 x 50 369.99

MARINE EQUIPMENT

Bushnell



H2O SERIES

Affordable Bushnell H2O binoculars are completely o-ring sealed for waterproof protection and Nitrogen purged for fogproof viewing in any season. Features include: •Durable rubber armoring •Center focus and full coated optics for durability and clarity.

60-014M.....	8 x 42	142.99
60-015M.....	10 x 42	159.99
60-016M.....	12 x 42	179.99

Bushnell



BUSHNELL POWERVIEW BINOCULAR

Great for examining detail at long range. Multi-coated optics for superior light transmission. Non-slip rubber armor absorbs shock while providing a firm grip. New Contemporary styling.

60-064M.....	10 x 50 mm	115.99
--------------	------------------	--------



BECKSON BINOCULAR HOLDER

Designed to hold that big pair at the ready. For binoculars, magazines, log books and tools. 8-1/4" Height. 8-3/4" Width. 2-3/4" Depth. 46-663P.....46.15

Bushnell



H2O SERIES COMPACT MODEL

BaK-4 prisms for bright, clear, crisp viewing. Multi-coated optics for superior light transmission. 100% waterproof: O-ring sealed and nitrogen purged for reliable, fog-free performance. Non-slip rubber armor absorbs shock while providing a firm grip. Fold-down or twist-up eyecups

Large center focus knob for easy, precise adjustments. Longer eye relief
 60-017M BLACK 10 x 25 CF89.99
 60-019M CAMO 10 x 25 CF99.99

Bushnell



BUSHNELL PERMA-FOCUS BINOCULARS

Built for comfortable long-range viewing, with 10x or 12x magnification and large, 50mm objective lenses.

- PermaFocus Technology - Keeps distant objects permanently in focus, eliminating the need for constant adjustment.
- Nitrogen Purged Fog-Proofing - Nitrogen inside the scope ensures interior optical surfaces won't fog due to humidity or rapid temperature change.
- Multi Coated Optics - Multiple layers of coatings on all lens surfaces increase light transmission and image brightness.

60-060M.....	10 x 50	149.99
60-061M.....	12 x 50	166.99

Bushnell



10 x 25mm

COMBO SPECIAL



10 x 50mm

BUSHNELL POWERVIEW 2 BINOCULAR COMBO KIT

Includes Bushnell Powerview 2 10 x 25mm Binocular & Bushnell Powerview 2 10 x 50mm Binoculars

- LONG LASTING DURABILITY Aluminum alloy chassis provides durability without adding unnecessary weight and bulk.
- MODERN EXTERIOR DESIGN High quality, soft touch rubber and brushed metal texture finishes provide classic performance in a great looking, modern design.
- EASY TO USE AND CONFIDENT GRIP Updated ergonomics with soft touch rubber and easy grip texture along the sides of the binocular, and on the bridge, reduce the chance of dropping and give a confident hand feel. Even with one hand.
- GREAT IMAGE QUALITY WITH SHARP FOCUS Multi-coated optics draw an incredible amount of light for clear vibrant images, even in low light. Ultra-smooth focus wheel allows you to focus in on your subject quickly for perfect definition when you need it.

60-065M.....	COMBO.....	128.99
--------------	------------	--------

Bushnell



POWerview COMPACTS

The PowerView series offers the largest line of Bushnell-quality, affordable binoculars. No matter what your purpose, you'll find a variety of magnifications, styles and sizes, and fully-coated optics for bright, vivid images. Standard-size models feature Insta-Focus for fast and easy focus on moving targets. Our mid-size roof prism models with 32mm objectives provide increased brightness for low-light viewing conditions.

- 60-076M8 X 21 / Black.....28.99
- 60-077M10 X 25 / Black.....37.99
- 60-078M12 X 25 / Black.....46.99

Bushnell



BUSHNELL PRIME RANGE FINDERS

With Advanced Target Detection the precise distance is always captured and confirmed with visual jolt. Industry leading features include hand-friendly ergonomic design allows effortless use. They offer true horizontal distance to target. Foreground and background object compensation. Fast and consistent response and readings. Also Target Acquisition Confirmation.

- Model LP1300SBL
- 60-717M.....6 x 24mm - 1300 Yards.....278.99

- Model LP1700SBL
- 60-718M.....6 x 24mm - 1700 Yards.....324.99



A: Angle reading. Competition up to 45 degrees.

B: Power meter indicated confidence of target acquisition.

Bushnell HD core Trail Cameras

The Bushnell CORE S-4K No Glow Trail Camera checks all the boxes successful hunters want the most. The highest picture resolution with a 4K Single Sensor for best in class image and video quality, plus optimized battery life for maximum image captures and more time in the field without checking batteries. All in a compact design to stay hidden from eyes you don't want to alert animal and human.



BUSHNELL CORE TRAIL CAMERA (30MP)NO GLOW

- Battery Life: Up to 12 Months
- Video Resolution: 4K
- Resolution: 30 Megapixels
- Video Length: Up to 60 seconds
- Storage Capacity: 512 GB
- Battery Type: AA (6)
- Colour: Camo
- Recovery Rate: 1.0 seconds
- Battery Tray: Removeable
- Recordable Audio: Yes
- Dynamic Video
- Pro Image Tuning
- 60-729MCAMO - 30 Mega Pixel.....219.99



Binoculars, Rangefinders & Trail Cam

MARINE EQUIPMENT

Prices are subject to change. Check our website for up to date prices. www.mercersmarine.com



GPS/Electronics





FUSION STEREO & SPEAKER KIT

MS-RA210 & 6.5" XS Sport Speaker Kit

Amplify the moment with the Fusion MS-RA210 premium marine stereo and XS Series speaker kit. This package puts the perfect soundtrack at your fingertips with everything you need to create an exceptional music experience in your boat at an outstanding value.

General Features:

- Marine digital media receiver with built-in Bluetooth music streaming
- 2.7" glass LCD color display
- Built-in Fusion DSP optimizes sound quality at all listening levels
- Feed-forward limiter anticipates peaks in the audio
- Multi-zone control lets you tune two audio zones
- Efficient Class D amplifier technology conserves battery power
- AM/FM tuner
- IPX6 and IPX7 water-resistant face
- Works with FUSION-Link app
- Inputs: rear USB port and AUX input
- 200 watts 6.5" XS Series Sports marine speakers

26-013K.....789.99



FUSION STEREO & SPEAKER KIT

MS-RA60 & 6.5" EL Sports Speaker Kit

Amplify the moment with the Fusion MS-RA60 premium marine stereo and EL Series speaker kit. This package puts the perfect soundtrack at your fingertips with everything you need to create an exceptional music experience in your boat at an outstanding value.

General Features:

- Built-in Bluetooth connectivity
- Daylight viewable 2.3" LCD display
- Built-in Class D amplifier
- 2-zone control
- AM/FM tuner
- Works with Fusion-Link and Fusion-Link Lite apps
- Meets IPX6 and IPX7 water resistant standards
- Inputs: auxiliary input (RCA)
- 200 watts 6.5" EL Series Sports marine speakers

26-002K.....469.99



FUSION MS-RA210 COMPACT STEREO

A compact marine stereo designed to deliver a quality audio experience out on the water. The sleek design with the option of either mounting the stereo with a conventional flush finish or integrating it flat ensures a visually appealing finish to your dash.

Features Bluetooth, AM/FM radio, iPhone/iPod, MTP, SiriusXM and DAB+ radio available, USB and AUX.

26-012K.....519.99



FUSION MS-RA60 MARINE STEREO

Designed and engineered for the harsh marine environment, the MS-RA60 stereo has an IPX6- and IPX7-rated water-resistant front panel to perform and last on board.

Take advantage of the multiple source options available, including BLUETOOTH technology, DAB+ radio, AM/FM radio and AUX connection.

26-001K.....279.99



FUSION ARX WIRELESS REMOTE

Control your audio entertainment from anywhere on your boat. This remote can be used across a variety of Fusion ANT-enabled products.

26-005K.....79.99



FUSION XS 6.5" 200W SPEAKERS WITH LED LIGHTING

The XS Series speakers are acoustically optimized for performance in the marine environment, by combining optimized speaker drivers and tweeters to produce quality sound at all volumes. LED illumination in a range of colors. The translucent cone disperses a bright, even illumination to set the tone on board. Extensively tested to perform in the harsh marine environment, the XS Series carry an IP65 weatherproof rating. Comes with Sports Grey and Sports White grille options.

26-025K.....289.99/pr.



FUSION XS 6.5" 200W SPEAKERS

Extensively tested to perform in the harsh marine environment, the XS Series carry an IP65 weatherproof rating. Two Grille Options Supplied: Enjoy the freedom to choose the finish to suit your vessel, with both Classic White and Classic Black grilles supplied in the box.

26-023K.....249.99/pr.



FUSION XS SERIES 4" 120W SPEAKERS

Optimized speaker drivers and tweeters to produce quality sound at all volumes. Extensively tested to perform in the harsh marine environment, the XS Series carry an IP65 weatherproof rating. Enjoy the freedom to choose the finish to suit your vessel, with both Classic White and Classic Black grilles supplied in the box.

26-024K.....179.99/pr.



For use with 26-025 above

FUSION RGB REMOTE FOR LED SPEAKERS

26-006K.....68.99



FUSION EL SERIES SPEAKERS

Use these speakers where you don't have much mounting depth thanks to its shallow design.

- Waterproof - (IP65 rated) resistant to rain, splash and spray
- UV resistant
- 6.5" polypropylene woofer cone
- 80 watts peak power each speaker
- 20 watts RMS (continuous) power each speaker
- Cutout diameter: 5-1/8"
- Mounting depth: 1-11/16"

26-003K.....149.99/pr.



FUSION MARINE BOX SPEAKERS

Great for on your boat or outside your home! Marine/Outdoor Two-Way Box Speakers are carefully crafted specifically for marine/outdoor use. Featuring an adjustable mounting bracket with all mounting hardware supplied, these speakers are perfect for installation on an aluminum vessel where flush mount speakers are not always practical.

- Watts: 100W peak
 - Dimensions: 5 3/8" W x 7 7/8" H x 5 7/16" D
- 26-004K.....109.99/pr.



FUSION ALL IN ONE PANEL STEREO

The ultimate all-in-one audio entertainment solution for the outdoors! IP65 weather resistance for protection against water and dust ingress, and now salt fog and UV resistance. Combining all the elements required for excellent audio reproduction inside a single perfectly tuned enclosure. Plug & Play All-In-One Audio Entertainment Solution - With built-in Class-D amplification, stereo source selection of Bluetooth, AM/FM radio, USB and AUX, two 3" speakers and a large surface bass radiator all combined in a perfectly tuned enclosure. Designed for easy installation, the Panel-Stereo only requires 12V dc power, ground and AM/FM antenna connections.

26-010K.....479.99



Shop or Browse Online 24/7 at mercersmarine.com

NEW



JENSEN AM/FM/USB BLUETOOTH 3" STEREO

Bluetooth streaming audio. Press and hold Bluetooth button for Quick Pairing in any mode. Waterproof. Weatherband. AM/FM tuner. Rear USB input for MP3 enabled devices. Rear AUX input. Line-out audio. Daylight-readable segmented LCD display and LED backlit buttons. Compact, self-contained design. Simple user interface. UV resistant finishes/materials and corrosion resistant.

26-366P389.99



JENSEN MSX60RVR WATERPROOF SPEAKERS

6.5" Coaxial Waterproof Speaker 75 watts Max power handling, ASTM B117

Salt Spray Exposure Standard Compliant, ASTM D4329
UV Exposure Standard Compliant, Gray, Sold as a pair.

26-154P 169.99/pr.



MS-5006W
26-150

AMS-602W
26-151



MARINE WEATHERPROOF SPEAKERS

•Dual cone speaker system •Weatherproof •High grade molded UV Resistant Plastic •Waterproof polypropylene dual cone construction •Mylar whizzer cone - 4.3 oz. magnet •MS-5006W has 50 watts (nominal power 15 W) •AMS-602W has 60 watts (nominal power 20 W) •New one piece designed frame, basket and slotted grill.

26-150P5" Diameter39.99 /pr.

26-151P6 1/2" Diameter64.99 /pr.



JENSEN USB INTERFACE AND 1/8" AUXILIARY INPUT JACK

Add a little something extra for the ultimate entertainment experience. JENAUX allows you to listen to all your favorite tunes by choosing to connect either your external storage device or iPod/MP3 player to the stereo using this waterproof port.

26-335P38.99



JENSEN AM/FM TOP OR SIDE MOUNT ANTENNA

AM/FM Antenna.Top or side Mount. Includes 60" Cable. 90 degree adjustable angle.

26-322P36.99



WEATHERPROOF SPEAKERS

These speakers can be surface or flush mounted. Wedge shaped can be mounted on any surface. For flush mounting, the grill can be removed. 5" woofer with tweeter, 80W peak power per pair. HDS-3000

26-296P129.99 /pr



JENSEN MARINE AN150SR AM/FM ANTENNA

AN150SR Jensen Amplified AM/FM stereo antenna Long-range amplified antenna is designed for demanding AM/FM listeners .Mounts easily using adhesive foam strips. Includes 7-foot cable along with 6 milliamps @ 12V DC. Perfect for marine applications

26-320P32.99



RADIO HOLDER

P.V.C. holder for VHF, C.B. or cell phones.

26-152R10.99



WATERPROOF COVER / CARRY BAG FOR HAND HELD VHF RADIOS

26-387R10.99

Marine Stereos & Speakers

MARINE EQUIPMENT



IT FLOATS!

ICOM "IC-M25" VHF H/H MARINE RADIO

11 Hours long battery Life. USB charging (Micro-B USB type). AquaQuake draining function. Slim body and lightweight. Large LCD, simple user interface. 550mW audio output. Optional speaker microphone, HM-213. IPX7 waterproof construction (1m depth of water for 30 minutes). 4-step battery life indicator. Weather channel with weather alert. Dual/Tri-watch functions. Instant access to Channel 16 or programmable call channel. Favorite channel function. Monitor function opens noise squelch.

- 26-087K..... 229.99
- 26-126K.....Speaker Mic 119.99



IT FLOATS!

ICOM "IC-M37" VHF H/H MARINE RADIO

Large keys and easy-to-grip design. 6 W RF Output power. 700 mW Audio Output. More than 12 Hours of long-lasting operating time. Channel history function stores the last five channels used for easy recall. IP57 dust-protection and waterproof protection (1 m depth of water for 30 minutes). Low battery alert function. Voice loud and mute function enables to temporary maximize/mute the volume. AquaQuake function prevents audio degradation from a water-logged speaker. Dualwatch and Tri-Watch functions. Favorite Channel function. Instant access to channel 16 and the Call channel. Weather channels with Weather Alert function.

- 26-089K..... 289.99
- 26-126K.....Speaker Mic 119.99



IT FLOATS!

AIS & DSC

ICOM "IC-M94D" VHF H/H MARINE RADIO

Icom M94D VHF Handheld Radio with DSC and AIS
Icom's Class H DSC VHF transceiver, the M94D is the world's first handheld to possess the power of AIS. A class-leading 1500 mW speaker and ocean-conscious features. A combination of the Automatic Identification System (AIS) and Distress Signal Calling (DSC) provides users with peace of mind when out on the open sea. Access vessel traffic information and plot up to 50 waypoints for fishing spots or man-overboard (MOB) waypoints.

The M94D's back-lit screen is dimmable for easy readability under any lighting condition. The large screen allows for easy to read icons and text.

Float'n Flash: If the M94D falls into water, the radio floats and automatically flashes, even when it is off. The LCD screen flashes to help show the radio's position to retrieve easily.

Aquaquake: If the M94D decides to take a swim, the AquaQuake draining function removes water from the grill by vibrating at a particular frequency, preventing audio degradation.

- 26-090H 449.99



ICOM M330 MARINE VHF RADIO

Built-in Class D DSC with a CH70 Dedicated Receiver. Easy-to-Read Full Dot-Matrix Display. IPX7 Submersible Construction. Ultra Compact Body. Easy Installation in Limited Space. New Speaker Delivers Dynamic, Clear Audio. Intuitive Operation with Icom Marine User Interface. Class Leading Receiver Performance.

- 26-096KBlack..... 279.99
- 26-240PFlush Mount 19.99



ICOM M330G MARINE VHF RADIO

M330G includes a **built-in GPS receiver** that shows **your current position and time and can be used for DSC calls**. GPS data source is selectable from internal and external GPS (and GPS-OFF setting). Built-in Class D DSC with a CH70 Dedicated Receiver. Easy-to-Read Full Dot-Matrix Display. IPX7 Submersible Construction. Ultra Compact Body. Easy Installation in Limited Space. New Speaker Delivers Dynamic, Clear Audio. Intuitive Operation with Icom Marine User Interface. Class Leading Receiver Performance.

- 26-098KBlack..... 369.99
- 26-240PFlush Mount 19.99



ICOM M424G MARINE VHF RADIO (CLASS D)

Intuitive User Interface and white backlit LCD and keypad. Active noise cancelling. 10W Loud Audio, Public Address and Foghorn. **Built-in Class D DSC. Built-in GPS receiver.** Common GPS/NAV Interface. MarineCommander™ Compatible.

- 26-103KBlack..... 499.99
- 26-240PFlush Mount 19.99

Uniden®



IT FLOATS!

UNIDEN ATLANTIS 275 VHF RADIO

The Uniden Atlantis 275 features all NOAA emergency weather channels, as well as all USA, International and Canadian marine channels. It also meets IPX7 submersible waterproof standards. The Atlantis' brilliant backlit LCD display makes it easy to use, day or night for the power to go anywhere. Floating Design. IPX7 Submersible Waterproof Level. 10-Hour Battery Life. 1W/2.5W/6W Transmit Power. Display Size: 18mm x 37mm. Power Boost Key. AC & DC Adapters. Included Charging Cradle. Glow Seals. Memory Scan. One Touch Channel 16/9 Key. Power Key

26-477P 215.99
26-483PSpeaker Mic 32.99

Uniden®



UNIDEN "MHS75" H/H VHF MARINE RADIO

Meets rigid JIS8 submersible. standards (5' 30 min.). Compact Size. Dual, Triple, and Quad Watch Plus. Selectable 1Watt/2.5/5 Transmit Power. All N.O.A.A. Weather Channels with Weather Alert. Rapid, Clip-On DC Charger. Memory Channel Scan. The LCD screen displays large, easy-to-read messages. Up to 12 Hour Battery Life. Covers all USA, International & Canadian marine channels keeping you up-to-date with all the latest marine activity. SMA Flexible Rubber Antenna. A sturdy belt clip is included for maximum mobility. **Does NOT take Mic.**

26-490P 179.99

Uniden®



VHF Radios

UNIDEN "SX167 2CH" TWO WAY RADIO

Designed for daily tasks or outdoor adventures, the Uniden FRS/GMRS 2-way radios boast an operational radius of 25.6km so you can stay in touch with friends and family. They feature 22 channels and receive weather alerts from Weatheradio Canada and NOAA to keep you abreast of current conditions. USB charger allows you to charge from any standard USB source

26-689P 64.99

Uniden®



UNIDEN "SX337-2CK" TWO WAY RADIO

Stay safe and keep in contact with the SX337 37-Mile Submersible 2-Way Radios from Uniden. Ideal for boating, hiking, and other outdoor pursuits, these palm-sized radios are lightweight, rugged and not just waterproof, but fully submersible.

26-693P 279.99



Uniden®

UNIDEN "UM385" VHF MARINE RADIO

Choose Uniden's space-saving 25-watt UM385 VHF Marine Radio for its full-featured capabilities, affordable price and upgraded design. Full class-D digital-selective-calling capability, including position send, test call, request and text. Receives all U.S., International and Canadian marine channels. NOAA emergency weather alert including S.A.M.E. LCD shows channel names, radio menu, DSC features and GPS data. Meets JIS4 waterproof level, which is splash-resistant. Orange-backlit LCD and buttons. Dual- and Triple-Watch modes.

26-480PWhite 219.99
26-482PBlack 219.99
26-240PFlush Mount 19.99



Uniden®

UNIDEN "UM435" VHF MARINE RADIO

Uniden's® short-chassis, fixed-mount UM435 VHF Marine Radio has been given an upgraded, space-saving design. Meets JIS-7 water-immersion standards (1 meter for 30 minutes). Features include: full class-D digital-selective calling, one-touch distress button, the ability to send and receive position information and Quik Command™ – a one-touch access to Coast Guard channels. High-performance transceiver receives emergency channels and NOAA weather alerts. Full-dot matrix display with intuitive menu.

26-466PWhite VHF 259.99
26-468PBlack VHF 259.99
26-240PFlush Mount 19.99

MARINE EQUIPMENT

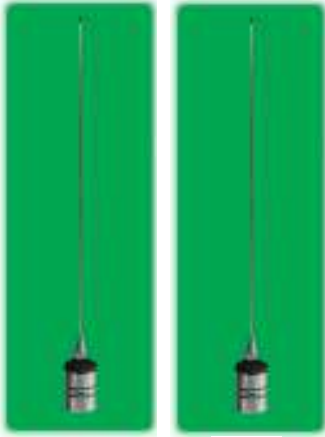

26-185
Model 5241-R



26-179
Model 5215



3' VHF ANTENNAS

Model 5241-R

Perfect for speedboats, center consoles, fishing boats, etc •For any vessel where a standard fiberglass antenna may be obstructive or impossible to install •Can be ratchet or rail mounted with center wire hole required •15' of co-ax cable & PL259 connector is supplied •36" S.S. whip •3 Db. gain •CPB ferrule.

26-185PModel 5241-R.....164.99

Model 5215

A favorite with Sailboat owners, this light weight, low profile, stainless steel antenna was specially designed for masthead mounting. Hermetically sealed, tin-plated copper wire coil. Stainless steel body and 36" S.S.whip. 50-239 connector. Stainless steel L-shaped bracket supplied for mounting. One section. 3 Db. gain.

26-179PModel 5215.....109.99



9 1/2' VHF ANTENNA - MAST MOUNT

An outstanding performer in a professional quality, two section antenna, providing strength and performance of a large antenna without the size •White Shakespeare fiberglass with a tapered tip •Brass & copper elements •C/P/B ferrules •9 1/2' overall. Co-Ax and connector NOT included.

26-184PModel 399-1M479.99



4' VHF ANTENNA

Model 5104

The Centennial antennas bring the best of the high-end features to an economical antenna. 5104 is a 4' 3dB antenna. Includes brass and copper elements, chrome-plated brass ferrules with standard 1"-14 thread and smooth, durable high-gloss finish. 15' RG-58 cable and PL-259 connector included.

26-182PModel 5104.....99.99



8' VHF ANTENNAS

Model 5101

A standard of excellence in an economical antenna •Brass element with a smooth high gloss polyurethane finish •8' overall •6 Db gain •C/W 15' RG-58 co-ax & PL-259 connector.

26-272PModel 5101.....124.99

26-183PModel 5102 (Commercial).....215.99



19' COMMERCIAL VHF ANTENNA

This 19' antenna is exceptional for long range communications •Antenna is rigid enough to stay erect in tough seas. •Yet this antenna is exceptionally lightweight •White Shakespeare fiberglass; brass & copper elements •Chrome plated brass ferrules •2 sections •19' overall •9 Db gain •Comes with 20 ft. Co-Ax and PL-259 connector.

Base Mount

26-186PModel 4018.....849.99

Mast Mount

Same specs as base mount only with base sleeve for mast mount. U-bolts supplied.

Does not include Co-Ax cable and connector.

26-187PModel 4018-M949.99



21' COMMERCIAL VHF ANTENNA

The ultimate in seagoing and land based antennas, the 476 is designed to get the message through when all others fail •It's the top choice of commercial vessels, such as workboats, tugs, tidal well service boats •2 3/4" dia. x 26" long aluminum sleeve can be strapped directly to a mast or used with Shakespeare's 483 clamp set or 484 wall mounting brackets •10 Db gain •Tapered Shakespeare fiberglass •Brass & copper internal elements •Co-Ax cable and connector not included •One section 21' overall length.

26-188PModel 4761699.99



10" VHF ANTENNA

Antenna kit includes 12' of cable, connector and suction cup for fast, easy mounting. Great for emergencies.

26-195PModel 5911.....119.99



3' MAG MOUNT V.H.F. ANTENNA

36" s.s. whip on magnetic base. Design for use on automobiles. C/W 12' Co-Ax cable with PL-259 connector attached. Not Shakespeare

26-265K.....109.99



8' CB ANTENNA

A tuneable, easily installed CB antenna for top performance in demanding situations. Connector is supplied but not installed, so only a 3/8" hole is required for passage of the cable. Includes 20ft RG-8/X cable and PL-259 connector.

26-206P.....Model 5223-XT289.99



23' S.S.B. ANTENNA

This award winning performer is often referred to as "the standard of the industry" by virtue of its capabilities and popularity •Reinforced insulating qualities allow power up to 1kw •Conductors are permanently sealed in Shakespeare's white fiberglass •The base ferrule has 1" - 14 threads •Chrome plated brass ferrules, two sections: base - 162" / tip 112", 23' overall length •Co-ax cable and connector not included.

26-205PModel 390.....469.99



28' PREMIUM S.S.B. ANTENNA

This heavy duty performer is designed primarily for larger commercial vessels which demand peak performances over the entire HF marine band •Conductors are permanently sealed in Shakespeare's white fiberglass •The 2-3/8" diameter x 24' long 6061-T-6 anodized aluminum sleeve can be strapped directly to a mast or used with Shakespeare's 483 clamp set or 484 wall mounting brackets (see page 190) •Chrome-plated brass center fittings •Anodized aluminum bottom ferrule •Two sections: Base 192"/Tip 144".

Co-ax cable and connector not included.

26-344PModel 5300.....749.99



GALAXY SIRIUSXM SATELLITE ANTENNA

Model SRA-50

Using the latest Satellite Radio technology, this SiriusXM Approved Accessory meets or exceeds the most recent specifications set forth by SiriusXM. This antenna is compatible with all radios and docks that work on the Sirius and XM networks with push on style, single input SMB connector. This antenna can be mounted on almost every possible surface with 4 different mounting options.

26-355P165.99



SHAKESPEARE 50 FT CABLE KIT

Model SRC-50

For longer cable runs, pick the appropriate length Shakespeare SRC Series cable kit for your installation. Connectors come pre-installed on all cables. These cable kits must be run as a single piece and cannot be joined together.

26-358P109.99



3' AM/FM ANTENNA

This 3ft combination antenna features Shakespeare's exclusive distributive load for super signal pulling power. The coil is permanently sealed in Shakespeare's white fiberglass. The Style 4351 has a nylon ferrule with 1in-14 thread for use with standard marine mounts. Includes 10ft RG-62 coax with Motorola plug installed. Nylon ferrule with standard 1"-14 thread. One section: 39" overall height.

26-204PModel 4351.....134.99



10' AM/FM EXTENSION CABLE

This 93-ohm RG-62 cable comes with male and female Motorola connectors installed. 10ft RG-62 coax. Plugs pre-installed. For use with 4357-S

26-196PModel 4352.....72.99



LOUD HAILER/HORN

Model HS-40

Gets your point across with up to 40 watts power handling capacity. This speaker also supports a loud-hailer listen-back function. It is made of high impact white plastic and includes a tilt mount bracket. Measures 7" wide x 13" deep. Operating temperature range: -40 to +80 C.

26-312RFor use with V.H.F. or C.B.229.99



AM/FM -VHF SEPARATOR

Eliminate the need for separate AM/FM antennas and operate AM/FM and VHF radios at the same time without interfering with VHF radio performance. Complete with 10-foot RG-62 AM/FM cable, 3-foot RG-58 VHF cable, and connectors.

26-300PModel 4357-S.....142.99



LOUD HAILER SPEAKER

Model HS-5A

Most VHF radios provide external audio outputs. These accessory speakers are color and performance matched to make installation a breeze. 5" white plastic horn speaker. 4 ohms. Handle 15 watts (RMS) input.

26-310RFor use with V.H.F. or C.B.68.99



4' AM/FM ANTENNA

Model 5420-XT

Bring in those stations. This Little Giant is in charge of the entertainment. Its sturdy construction and outstanding performance make it an excellent choice for T-tops, Hard-tops and other elevated mounting positions. Extra rigid, extra tough. Solid performance packed into an extra heavy-duty radome. Copper elements to maximize range. Stainless steel ferrule with standard 1in-14 thread. Includes 12 feet RG-62 cable with Motorola type plug installed. Frequency: AM, FM, and FM-stereo. One section.

26-193PModel 5420-XT225.99



AM/FM GLASS MOUNT ANTENNA

This design lets you put an AM/FM antenna on your boat where it will not get in the way -It is a clear tape with embedded antenna elements -Its permanent adhesive strip lets you attach it quickly to your boat's windshield or any non-metallic surface -Comes with 6' cable and attached plug.

26-212PModel 4353.....82.99



EXTERNAL SPEAKER FOR VHF/CB

Weatherproof external speaker for VHF or C.B. radios.

26-093RES-4 (3 1/2"W x 3 1/2"H)97.99



RATCHET BASE

Stainless steel. Standard 1" x 14 threads.

26-069R.....64.99



SWIVEL MOUNT BASE

Chromed brass swivel base for deck or side mounting. Base is dual joint, free pivot. Allows easy lowering.

26-200R.....123.99



CO-AX CABLE

RG-8 X.

26-264R.....1.29 /ft.



NYLON RATCHET BASE

26-070R..... Standard 1" x 14 threads.....22.99



STRAIGHT MOUNT ANTENNA BASE

Standard 1" x 14 threads. Stainless construction, 4" high. Great for radar arches.

26-201R.....29.99



SOLDERLESS PL-259 CONNECTOR

This Centerpin Solderless connector offers as good a join as solder connectors. Fits RG-58, RG-8, or A/U co-ax cable.

26-295R.....23.99



STAND-OFF BRACKET

Heavy duty upper support bracket for use with larger, heavier antennas. Fits 1" or 1 1/2".

26-072R.....35.99



RAIL MOUNT BASE

This stainless steel rail mount antenna base will fit 7/8" and 1" tubing.

Standard 1" x 14 thread.

26-460RStainless Steel.....79.99



CO-AX CABLE FITTINGS

PL-259 Cable Ends

26-078R.....9.99



CO-AX COUPLER

26-077R.....PL-2583.59



24" STAINLESS STEEL ANTENNA EXTENSION

Stainless steel pipe extension with male and female ends. For use on VHF's or GPS units.

26-464R.....72.99

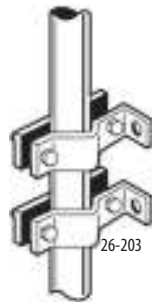

26-203

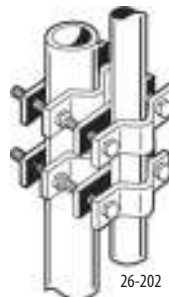

26-202

BRACKETS FOR MODEL 476 ANTENNA

Wall Mount Brackets

26-203P#48489.99

Mast Clamp Brackets

26-202P#483209.99



PL-258-CPB SPLICE CONNECTOR

The perfect solution to the troublesome task of installing a PL-259 connector or splicing RG-58 A/U, RG-8/X or Lo-Max coaxial cables. Solderless, fret-less, and botchless.

26-298R.....32.99



ZOLEO SATELLITE COMMUNICATOR

Meet ZOLEO, the affordable accessory that extends your smartphone messaging coverage to everywhere on Earth and provides a safety system you can count on. Ruggedly designed, location-aware and Iridium-based, the ZOLEO satellite communicator device will keep you connected and secure when venturing beyond cell coverage. Simply connect ZOLEO with the free Zoleo app on your smartphone to send and receive messages anywhere on earth, and a whole lot more.

For added peace-of-mind, built-in Check-in and SOS buttons help keep you safe — even if your smartphone is damaged or out of battery life.

- Weight: 150 g (5.3 oz)
- Size 3.58"L x 2.6"W x 1.06"D
- Ingress Protection: IP68; dust- and water-resistant (to 1.5 m (4.9 ft) for 30 min)
- Shock-resistant: MIL-STD 810G
- Power input: Micro-USB Type B connector
- Covered SOS button prevents false alarms (also cancellable)
- Audible alerts for messages (user-selected tone)
- Internal GPS chip, location-aware (accurate to 2.5 m (8.2 ft))
- LEDs for: messages, SOS, check-in, and power
- Battery: Rechargeable internal Lithium Ion
- Battery life: 200+ hours
- Charging time: 2 hours using 1.5 A charger

ZOLEO SATELLITE COMMUNICATOR

26-116H 269.99



GARMIN INREACH MINI 2

This compact satellite communicator helps you keep home with you when you're off the grid — adding peace of mind to every adventure, without adding weight to your pack.

- Exchange text messages with loved ones back home, post to social media, or communicate inReach to inReach in the field.
- In case of emergency, trigger an interactive SOS message to the Garmin IERCC, a 24/7 staffed emergency response coordination center.
- Share your location with loved ones back home at any time using your MapShare™ page or with your coordinates embedded in your messages.
- Instead of relying on cellphone coverage, your messages, SOS alerts and location tracking are transferred via the global Iridium® satellite network.
- To access the Iridium network and communicate with your inReach Mini 2, an active satellite subscription is required. You can opt for an annual package or a flexible month-to-month plan.
- Don't let the 4" x 2" size and 3.5 oz weight fool you. inReach Mini 2 is tough, durable, impact resistant (MIL-STD-810) and water-rated to IPX7.
- The TracBack routing feature navigates you back to your starting point the same way you came, should you get lost — right on your device.
- Get accurate heading information — even when you're not moving.
- The internal, rechargeable lithium battery gives you up to 14 days use at the default 10-minute tracking mode and up to 30 days with a 30-minute tracking interval.
- Get detailed weather updates on inReach Mini 2 or a paired compatible device. You can even request forecasts for your current location or other waypoints or destinations on your itinerary.
- Get free access to the cloud-powered Garmin Explore website on your computer to plan your trips, create preset messages and quick texts, sync and manage your device settings, and much more.

GARMIN INREACH MINI 2

26-115J 539.99



GARMIN INREACH MESSENGER

If you're venturing off the grid, this small, rugged satellite communicator goes beyond the limits of cellular networks to keep friends and family in reach with global two-way text messaging.

- A simple user interface through the Garmin Messenger app on your smartphone makes it easy to exchange text messages via satellite or cellular networks.
- Optimized inReach messaging uses a cellular connection of your smartphone when it's available, then it seamlessly switches to a 100% global Iridium satellite network when you go beyond available cellular coverage range.
- With the Garmin Messenger app, your inReach connection supports group message threading and distribution. So, you can share your adventures with multiple contacts and have group text chats with friends and family.
- In case of emergency, trigger an interactive SOS message to Garmin Response, a 24/7 emergency response center.
- Share your location anytime by using your MapShare page or with your GPS coordinates embedded in your messages.
- To access the global Iridium network and communicate with your inReach Messenger device, an active satellite subscription is required. You can opt for an annual package or a flexible month-to-month plan.
- Don't let the 3.1" x 2.5" size and 4 oz weight fool you. inReach Messenger is tough, durable, impact-resistant and water-rated to IPX7.
- If you're smartphone battery dies, just connect inReach Messenger to your phone for enough safety charge to send a custom text message from the inReach Messenger device via your phone's touchscreen.
- The internal, rechargeable lithium battery gives you up to 28 days of battery life in 10-minute tracking mode, so you can do what you love longer between recharges.

GARMIN INREACH MESSENGER

26-109H 389.99

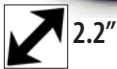

GARMIN ETREX 10

•eTrex 10 retains the core functionality, rugged construction, affordability and long battery life that made eTrex the most dependable GPS device available. We improved the user interface and added a worldwide basemap, paperless geocaching and support for spine-mounting accessories.

•eTrex 10 has an enhanced 2.2" monochrome display that's easy to read in any lighting situation. Both durable and waterproof, eTrex 10 is built to withstand the elements. Its easy-to-use interface means you'll spend more time enjoying the outdoors and less time searching for information. eTrex 10 features the legendary toughness that's built to withstand the elements. Dust, dirt, humidity, water — none are a match for this navigator.

•With its high-sensitivity, WAAS-enabled GPS receiver and HotFix® satellite prediction, eTrex 10 locates your position quickly and precisely and maintains its GPS location even in heavy cover and deep canyons. Whether you're in deep woods or just near tall buildings and trees, you can count on eTrex 10 to help you find your way when you need it the most.

•Take charge of your next adventure with BaseCamp™, software that lets you view and organize maps, waypoints, routes, and tracks. This free trip-planning software even allows you to create Garmin Adventures that you can share with friends, family or fellow explorers. Note : This eTrex 10 cannot accept detailed mapping For more information please visit www.mercersmarine.com.

26-016J.....Complete Unit (W/O Power Cord)..... 139.99

Accessories

26-416J.....Power Cord..... 36.99

26-802K.....Ram Mounting Bracket..... 62.99

26-420J.....Carrying Case..... 24.99



GARMIN ETREX SE

Adventure easily with this simple-to-use GPS handheld with extra battery life, wireless connectivity and multi-GNSS support — so you can enjoy exploring more.

•Access multiple global navigation satellite systems (GPS, GLONASS, Galileo, BeiDou and QZSS) to track in more challenging environments than GPS alone.

•Follow your bearing on the digital compass, which provides an accurate heading even when stationary.

•When connected to the Garmin Explore app, you can get real-time forecast information, so you're aware of the changing conditions.

•Connect with the Garmin Explore app for wireless software updates, cloud storage, trip planning, smart notifications and additional mapping.

•Get long battery life of up to 168 hours in standard mode and up to 1,800 hours in expedition mode with 2 field-replaceable AA batteries (not included).

26-017J.....Complete Unit (W/O Power Cord)..... 199.99

Accessories

26-795K.....Ram Spine Cradle.....24.99

26-420J.....Carrying Case..... 24.99

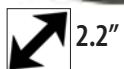

GARMIN ETREX 22X WITH TOPO

Explore confidently with the reliable handheld GPS

•2.2" sunlight-readable colour display with 240 x 320 display pixels for improved readability

•Preloaded with **TopoActive maps** with routable roads and trails for cycling and hiking

•Support for GPS and GLONASS satellite systems allows for tracking in more challenging environments than GPS alone

•8 GB of internal memory for map downloads plus a microSD™ card slot

•eTrex 32x adds a 3-axis compass and barometric altimeter

•Battery life: up to 25 hours in GPS mode with 2 AA batteries

26-021J.....Complete Unit (W/O Power Cord)..... 269.99

Accessories

26-416J.....Power Cord..... 36.99

26-802K.....Ram Mounting Bracket..... 62.99

26-420J.....Carrying Case..... 24.99

GARMIN GPSMAP 65 WITH TOPO

Explore more with this rugged handheld that offers multi-band frequency support for our most accurate position to date, a 2.6" color display and preloaded maps.

- Preloaded **TopoActive U.S. and Canada maps** show you terrain contours, topographic elevations, summits, parks, coastlines, rivers, lakes and geographical points.
- Receive emails, texts and alerts right on your handheld when paired with your compatible device.
- Plan, review and sync waypoints, routes and tracks by using the Garmin Explore app¹ and website. You can even review completed activities while still in the field.
- Using your compatible device and microSD memory card, conveniently download TOPO 24K maps and hit the trail, or access HuntView Plus maps to see public land types and boundaries as well as private landowner names and boundaries.

System sold without Power Cord. Power Cord is available below. For more information please visit www.mercersmarine.com

26-704JComplete Unit (W/O Power Cord)**449.99**

Accessories

26-416JPower Cord**36.99**

26-809KRam Mounting Bracket**62.99**

26-414JCarry Case**24.99**



Floats



Floats

GARMIN GPSMAP 79S

These rugged, floating handhelds feature sunlight readable, high-resolution color displays that are fog proof and scratch-resistant. You get access to a range of satellite constellations, so you get more reliable, accurate tracking around the world. Navigate wherever your adventures take you with options for worldwide basemap or built-in BlueChart g3 coastal charts. With more memory than previous models, you can save and track 10,000 waypoints and 250 routes. Keep your bearings with the built-in compass.

- This handheld is water-resistant (IPX7) with a high-resolution color display you can read in the sun. The glass is even scratch resistant and fog proof.
- If rough waters come and the handheld goes overboard, don't worry. This device floats.
- User-replaceable AA batteries (not included) provide up to 19 hours of battery life in GPS tracking mode.
- The 3-axis tilt-compensated electronic compass shows your heading, even while the boat is standing still.

System sold without Power Cord. Power Cord is available below. For more information please visit www.mercersmarine.com

26-703JComplete Unit (W/O Power Cord)**389.99**

Accessories

26-411JPower Cord**29.99**

26-795KRam Spine Cradle with 1" Ball**24.99**

26-414JCarry Case**24.99**

GARMIN GPSMAP 67

Make more time for adventure with this premium, rugged handheld. Get long battery life and multi-band technology for enhanced accuracy plus preloaded TopoActive maps and access to satellite imagery.

- Navigate every trail with ABC sensors, including an altimeter for elevation data, barometer to monitor weather and 3-axis electronic compass.
- Download high-resolution photorealistic maps directly to your device via Wi-Fi technology. Easily find trails, pick stand locations and parking, create waypoints and more.
- Preloaded **TopoActive U.S., Mexico and Canada maps** show you terrain contours, topographic elevations, summits, parks, coastlines, rivers, lakes and geographical points.
- The GPSMAP 67 series helps you keep gear to a minimum with a built-in LED flashlight that can be used as a beacon to signal for help, boundaries, BLM boundaries and more.
- When connected to the Garmin Explore smartphone app, you can get real-time forecast information, so you're aware of the changing conditions.
- The internal lithium-ion rechargeable battery provides up to 180 hours of battery life in GPS mode and up to 840 hours in expedition mode.

26-728JComplete Unit (W/O Power Cord)**669.99**

Accessories

26-576JHigh Speed Multi-Charger**49.99**

26-795KRAM Spine Cradle with 1" ball**24.99**

26-414JCarry Case**24.99**





GARMIN GPSMAP 66i

Precise navigation meets global communication in the rugged GPSMAP 66i button-operated GPS handheld and satellite communicator featuring Garmin TopoActive mapping and inReach technology.

- Navigate every trail with ABC sensors, including an altimeter for elevation data, barometer to monitor weather and 3-axis electronic compass.
- Download high-resolution, photo-realistic maps directly to your device without an annual subscription. Easily find trails, pick stand locations, find parking, create waypoints and more.
- Preloaded TopoActive U.S. and Canada** maps show you terrain contours, topographic elevations, summits, parks, coastlines, rivers, lakes and geographical points.
- Exchange text messages with loved ones, post to social media, or communicate from inReach to inReach in the field (satellite subscription required).
- In case of emergency, trigger an interactive SOS message to Garmin ResponseSM, a 24/7 staffed professional emergency response coordination center (satellite subscription required).
- Track your location, and share it with those at home or out in the field. They'll be able to see your progress or ping your device for your GPS location and more (satellite subscription required).
- Instead of relying on cellphone coverage, now your messages, SOS alerts and tracking are transferred via the global Iridium satellite network (satellite subscription required).
- Use inReach connectivity to get detailed weather updates on GPSMAP 66i or a compatible device paired with the Garmin Explore app. Request weather forecasts for your current location, waypoints or destinations on your route.
- When paired with your compatible smartphone, you can get real-time forecast information and live weather radar, so you're always aware of the surrounding conditions.

26-727J	Complete Unit (W/O Power Cord)	699.99
Accessories		
26-576J	High Speed Multi-Charger	49.99
26-795K	RAM Spine Cradle with 1" ball	24.99
26-414J	Carry Case	24.99

GARMIN GPSMAP 67i

Make more time for adventure with this premium, rugged GPS handheld and satellite communicator. Get inReach technology that enables two-way messaging, interactive SOS alerts and location sharing plus mapping to keep you on course.

- Navigate every trail with ABC sensors, including an altimeter for elevation data, barometer to monitor weather and 3-axis electronic compass.
- Download high-resolution, photorealistic maps directly to your device via Wi-Fi technology. Easily find trails, pick stand locations and parking, create waypoints and more.
- Preloaded TopoActive U.S., Mexico and Canada** maps show you terrain contours, topographic elevations, summits, parks, coastlines, rivers, lakes and geographical points.
- Turn on expedition mode, and get up to 425 hours of battery life while using inReach technology. In the default tracking mode, you get up to 165 hours of battery life, and your device will save your location every 10 minutes.
- Exchange text messages with loved ones, post to social media, or communicate from inReach to inReach in the field.
- In case of emergency, trigger an interactive SOS message to the Garmin ResponseSM center, a 24/7-staffed professional emergency response coordination center.
- Track your location and share it with those at home or out in the field. They'll be able to see your progress or ping your device for your GPS location and more.
- Instead of relying on cellphone coverage, now your messages, SOS alerts and tracking are transferred via the global Iridium satellite network.
- Download the Garmin Messenger app to your compatible smartphone, and pair it with your GPSMAP 67i handheld for fast, easy messaging and 24/7 SOS that's not limited to cellphone coverage areas.
- Plan, review and sync waypoints, routes and tracks by using the Garmin Explore app and website. You can even review completed activities while still in the field.
- Use inReach connectivity to get detailed weather updates on the GPSMAP 67i handheld. Request weather forecasts for your current location, waypoints or destinations on your route.



26-729J	Complete Unit (W/O Power Cord)	799.99
Accessories		
26-576J	High Speed Multi-Charger	49.99
26-795K	RAM Spine Cradle with 1" ball	24.99
26-414J	Carry Case	24.99



GARMIN MONTANA 700

With routable mapping for roads and trails, the Montana 700 handheld brings advanced outdoor features into a sturdy 5" format that's ideal for navigation on foot, bike, kayak, ATV and more.

- This durable, water-resistant handheld is tested to U.S. military standards and features a glove-friendly 5" touchscreen that's 50% larger than previous Montanas.
- Preloaded topographical maps for the U.S. and Canada. View terrain contours, elevations, coastlines, rivers, landmarks and more.
- Optional display of federal public land boundaries on topographical maps.
- Use direct-to-device downloads of BirdsEye Satellite Imagery (no annual subscription required) to see photo-realistic views and create waypoints based on landmarks.
- With 16 GB of onboard memory and a microSD card slot for expandable storage, you can download even more maps such as City Navigator for your drive or BlueChart g3 for the water.
- Navigate your next trail with ABC sensors, including an altimeter for elevation data, barometer to monitor weather and 3-axis electronic compass.
- Use cellular connectivity to access up-to-date Active Weather forecasts through the Garmin Connect app.
- Syncs with compatible Astro or Alpha series handhelds (sold separately) to help track dogs.
- This preloaded app lets you easily download hiking, cycling and other Wikiloc trails shared by outdoor enthusiasts like you.
- System sold without Power Cord.

26-710JComplete Unit809.99
Accessories		
26-576JHigh Speed Multi Charger49.99
26-036JAmps Mount119.99
26-040JBattery129.99
26-421JAA Battery Pack48.99



GARMIN MONTANA 700i

To keep adventurers in touch and on track, the Montana 700i handheld combines the flexibility of on-or-off-road navigation with global messaging and interactive SOS via inReach satellite technology.

- Exchange text messages, post to social media, or communicate via inReach device to inReach device in the field (subscription required).
- In case of emergency, trigger an interactive SOS message to GEOS, the Garmin-powered International Emergency Response Coordination Center (IERCC) with professional 24/7 global monitoring and response center (subscription required).
- Instead of relying on cellphone coverage, now your messages, SOS and tracking are transferred via the 100% global Iridium satellite network (subscription required).
- Available inReach weather forecast service provides detailed updates directly to your device.
- Durable and water-resistant. Tested to U.S. military standards and features a glove-friendly 5" touchscreen.
- Road navigation with preloaded City Navigator street mapping, which guides your drive with easy-to-follow turn-by-turn directions.
- Preloaded topographical maps for the U.S. and Canada.
- Features BirdsEye Satellite Imagery (no annual subscription required) to see photo-realistic views and create waypoints based on landmarks.
- Includes an altimeter for elevation data, barometer to monitor weather and 3-axis electronic compass.
- Use cellular connectivity to access up-to-date Active Weather forecasts through the Garmin Connect app.
- System sold without Power Cord.

26-711JComplete Unit939.99
Accessories		
26-576JHigh Speed Multi Charger49.99
26-036JAmps Mount119.99
26-040JBattery129.99
26-048JGPS/Iridium Antenna119.99



GARMIN MONTANA 750i

The rugged Montana 750i handheld combines the flexibility of on- or off-road navigation with global messaging and interactive SOS via inReach satellite technology plus a built-in 8-megapixel camera.

- Exchange text messages, post to social media, or communicate via inReach device to inReach device in the field (subscription required).
- For emergency, trigger an SOS message to GEOS, a professional 24/7 global monitoring and response center (subscription required).
- Instead of relying on cellphone coverage, now your messages, SOS and tracking are transferred via the 100% global Iridium satellite network (subscription required).
- Available inReach weather forecast service provides detailed updates directly to your device.
- Durable and water-resistant. Tested to U.S. military standards and features a glove-friendly 5" touchscreen.
- 8-megapixel camera. It geotags photos with coordinates, so you can navigate back to favorite sites in the future.
- Preloaded City Navigator street mapping with easy-to-follow turn-by-turn directions.
- Preloaded topographical maps for the U.S. and Canada.
- Features BirdsEye Satellite Imagery (no annual subscription required) to see photo-realistic views and create waypoints based on landmarks.
- Includes an altimeter for elevation data, barometer to monitor weather and 3-axis electronic compass.
- Use cellular connectivity to access up-to-date Active Weather forecasts through the Garmin Connect app.
- An internal, rechargeable lithium-ion battery pack provides more than 18 hours of battery life in GPS mode.
- System sold without Power Cord.

26-712JComplete Unit1079.99
Accessories		
26-576JHigh Speed Multi Charger49.99
26-036JAmps Mount119.99
26-040JBattery129.99
26-048JGPS/Iridium Antenna119.99

GARMIN GPSMAP 276CX

GPSMAP 276Cx was designed for your rugged lifestyle. You'll navigate with confidence by seeing clearly on the large **5-inch sunlight-readable screen**. The navigator's flexible mounting lets you keep the device exactly where you need it. Operate GPSMAP 276Cx with its reliable push-button controls that resist dirt, dust and grit, and best of all, keep all your maps on hand with 8 GB of internal memory, expandable by a microSD™ card (sold separately).

Almost anywhere you want to go, GPSMAP 276Cx has a compatible map to take you there. It comes preloaded with worldwide basemap and includes a free 1-year BirdsEye Satellite Imagery subscription. It also supports a variety of other mapping options such as Garmin TOPO maps, BlueChart® g2 HD, and turn-by-turn directions on City Navigator® NT.

Internal antenna with GPS and GLONASS satellite reception for tracking in more challenging environments than GPS alone; for better reception in vehicle interiors add an external antenna (sold separately) to the built-in MCX connector

Supports Active Weather forecasts and animated weather tracking. Pairs with your compatible smartphone for automatic uploads, smart notifications and more. For more information please visit www.mercersmarine.com

Package includes:

- GPSMAP 276Cx
- 1 year BirdsEye Satellite Imagery subscription
- AMPS powered mounting bracket with marine bail mount
- Lithium-ion rechargeable battery pack
- USB cable
- AC charger

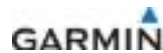

GPS



26-702H.....Complete Unit.....	779.99
Accessories	
26-045J.....Protective Cover.....	24.99
26-046J.....Screen Protector.....	24.99
26-041J.....Garmin Wireless Temp. Sensor.....	46.99
26-044J.....Replacement Battery.....	98.99



www.mercersmarine.com



- Always Open
- Sale & Feature items
- View Catalogue



- Thousands of products
- Updated Regularly
- Up to date Pricing



- Mobile Friendly
- Shop from anywhere at anytime

Also find us on

GPS ELECTRONICS

Prices are subject to change. Check our website for up to date prices. www.mercersmarine.com



GARMIN TREAD BASE EDITION 5.5"

26-715J809.99

GARMIN TREAD BASE EDITION

- Purpose-built for all-terrain use, Tread stands up to anything the elements can throw at it. It's IPX7-rated for water-resistance and built to U.S. military standard 810 for thermal and shock resistance.
- With its ultrabright 5.5" glove-friendly touchscreen, the Tread navigator is designed for easy viewing in bright sunlight or pitch dark. It can be mounted in portrait or landscape mode.
- Tread features preloaded topographic maps of North and Central America and detailed street maps of North America. It also includes trail maps for full-sized 4x4s, side-by-side, ATVs and motorcycles.
- Download high-resolution BirdsEye Satellite Imagery directly via Wi-Fi connectivity, with no annual subscription required.
- Use the Tread app to sync waypoints, tracks, routes and collections across your devices, including your mobile device, computer and Tread navigator. Easily import and share GPX files, too.
- For tough-terrain guidance, built-in sensors include an altimeter, barometer, compass and pitch/roll gauges.
- Pair your Tread powersport navigator with one of the compatible inReach global satellite communicators (sold separately) for two-way text messaging, interactive SOS and weather.
- Get spoken turn-by-turn directions if you choose to take Tread with you when you head back to civilization and want on-road navigation. This includes driver alerts for sharp curves, red light/speed cameras and more.
- Weather ahead? Pair Tread with your compatible smartphone, and download the Tread app to access live weather, storm alerts, animated radar and more.
- A built-in media player lets you control music loaded on your compatible smartphone on the navigator's display.



GARMIN TREAD OVERLAND & XL EDITIONS WITH INREACH

- Built for every part of the journey, this rugged all-terrain navigator has the mapping you need to stay on track and communication technology to stay in touch while you're out there.
- Purpose-built for all-terrain use, this Tread device stands up to anything the elements can throw at it. It's IP67-rated for water-resistance.
- With its ultrabright 8" glove-friendly touchscreen, the navigator is designed for easy viewing in bright sunlight or pitch dark. It can be mounted in portrait or landscape mode.
- Enjoy turn-by-turn trail navigation for traversing unpaved roads and trails using adventure roads and trails map content comprised of OSM and USFS Motor Vehicle Use Maps.
- Built-in inReach technology offers global satellite communication, two-way text messaging, location sharing and interactive SO
- Tread includes preloaded topographic maps with 3D terrain for North and South America. It also includes detailed street maps of North America with custom routing for the size and weight of your rig.
- Enjoy vivid aerial views when you download high-resolution BirdsEye Satellite Imagery directly to your device via Wi-Fi connectivity, with no annual subscription required.
- Tread comes preloaded with iOverlander points of interest and Ultimate Public Campgrounds, so you don't need a cell signal to route to the best-established, wild and dispersed campsites.
- When you're headed to tough-terrain, the built-in sensors will come in handy — including an altimeter, barometer, compass and pitch/roll gauges.
- Use the included locking magnet-assisted mount to secure the navigator to your vehicle.



GARMIN TREAD OVERLAND 8" WITH INREACH

26-717J1749.99



GARMIN TREAD XL 10" WITH INREACH

26-718J2019.99



RAM stands for Round-A-Mount and got its start in 1995. Most of the product line is based on a patented design revolving around a rubber ball and socket design. Far and away the most innovative product line of its kind, RAM continues to evolve into one of the most sought after accessories for electronics.



RAM HANDLEBAR U-BOLT MOUNT FOR GARMIN AMPS MOUNT

U-bolt base, double socket arm and 2" x 1.7" rectangular base that contains the universal AMPS hole pattern. The diamond adapter base has a hole pattern that matches the industry standard AMPS hole pattern and will connect to a large variety of RAM Mount and third party cradles.
26-084K.....58.99



RAM DRILL DOWN MOUNT FOR GARMIN AMPS MOUNT

Drill-down mounting solution; rectangle plate features AMPS hole pattern for attachment to compatible device holders. Includes round ball base, rectangle ball base, and B size long length double socket arm; ball and socket technology allows for near-infinite adjustability
26-082K.....46.99



RAM MOUNT "BIG-SCREEN MAGNIFIER"

The magnifier is 2 inch by 4 inch with 2x zoom. The difference this device makes in the overall functionality of the GPS or PDA is remarkable. The unit comes with a diamond adaptor, so it works with all RAM cradles and a ratcheting feature with flex rod for perfect positioning. This RAM Big Screen Magnifier is a must have for anyone who loves their GPS or PDA but wishes the screen was a little larger.
26-808K.....62.99



RAM FLAT SURFACE MOUNT FOR THE GARMIN ETREX 10, 20 & 30

Consists of a double socket arm, 2.5" diameter round base with the universal AMPS hole pattern, diamond adapter base & high strength composite cradle. Designed into the mount is a 1" diameter patented rubber ball and socket system with adjustment points at the base and cradle.
26-802K.....62.99



RAM "FLAT SURFACE" MOUNT FOR GARMIN OREGON SERIES

The RAM flat surface mount consists of the 1" dia. ball and socket system with RAM composite cradle for the Garmin Oregon 450/550, & 600/650 Series.
26-806K.....62.99



RAM FLAT SURFACE MOUNT FOR THE GARMIN MONTANA SERIES (600 SERIES ONLY)

Consists of a double socket arm, 2.5" diameter round base with the universal AMPS hole pattern, diamond adapter base and custom high strength composite cradle. Designed into the mount is a 1" diameter patented rubber ball and socket system with adjustment points at the base and cradle.
26-811K.....62.99



RAM MOUNT FOR GARMIN GPSMAP 78

The Garmin GPSMAP 78 Flat Surface Mount. 1" Rubber ball and socket technology allows for almost infinite adjustment and perfect viewing angles.
26-807K.....62.99



RAM MOUNT FOR GARMIN GPSMAP 64/65

The RAM-B-138-GA41 RAM Mount is a Marine Grade Aluminum Mount with a Flat Surface Screw Down Base and RAM Custom Plastic Cradle. The mount is designed with a RAM 1" diameter patented rubber ball and socket system that has adjustment point at the cradle and base.
26-809K.....62.99



RAM CRADLES

- 26-792KFor 78 Series24.99
- 26-794KFor 62/64 Series22.99
- 26-796KFor Oregon Series23.99
- 26-798KFor Montana Series23.99



RAM AMPs BASE WITH 1" BALL

Consists of a 1" diameter rubber ball connected at right angles to a 2" x 1.7" square base. The base has four pre-drilled holes at each corner, making the universal 1.5 x 1.188 (hole spacing) AMPs hole pattern.

- 26-059K14.99



RAM SPINE CLIP HOLDER WITH BALL FOR GARMIN HANDHELD DEVICES

This spine mount adapter easily clips into the integrated spine connection on a wide variety of Garmin devices. For use in nearly any application, the included B size diamond base adapter and hardware allows you to connect your Garmin handheld to any RAM B size mounting base.

- 26-795K24.99



RAM FINGER-GRIP UNIVERSAL PHONE AND RADIO HOLDER

Holds a large variety of cell phones and electronic devices. The cradle comes with (3 sets) of 4 flexible rubber coated fingers placed along sides to grip your device. The bottom of the cradle includes a back plate that adds support to the device being held by the mount. The spine plate contains the universal AMPs and 1.5" x 2" hole patterns.

- 26-080K53.99



RAM UNIVERSAL X-GRIP® CELL/IPHONE CRADLE WITH B-SIZE 1" BALL

If you are looking for a compact mount for your cell phone without that cookie cutter shape, you've found it. The RAM X-Grip® has a clean and clever four leg design that sports great holding power without hiding your phone behind foam pads and plastic.

- 26-058K58.99



RAM MEDIUM TOUGH-CLAW WITH 1" DIAMETER RUBBER BALL

The RAM Tough-Claw is the perfect mounting base for quick and easy tool-less installation and removal on round, square, odd shaped rails and bars. The Tough-Claw can be clamped on rails from 1" to 1.875" outer diameter. Ideal for mounting tablets, action cameras, smartphones, rod holders for rod storage and much more in a wide variety of applications. Perfectly suited for mounting on the yoke of an aircraft, handlebars and seat posts of bicycles, kayak rails, roll bars and much more.

- 26-066K65.99



RAM 2.38" ARM

The RAM-B-201U-A, short double socket arm, has a socket at both ends that accommodates 1" ball bases. RAM socket technology allows for almost infinite adjustment and perfect viewing angles.

- 26-053K24.99



RAM 3.69" ARM

The RAM-B-201, standard double socket arm, has a socket at both ends that accommodates 1" ball bases. A single spring inside the arm opens the end sockets, allowing you to pivot the ball and socket connection. This socket technology allows for almost infinite adjustment and perfect viewing angles.

- 26-051K26.99



RAM 6" ARM

The RAM-B-201-C, long double socket arm, has a socket at both ends that accommodates 1" ball bases. A single spring inside the arm opens the end sockets, allowing you to pivot the ball and socket connection. This socket technology allows for almost infinite adjustment and perfect viewing angles.

- 26-052K44.99



RAM BASE & SUCTION CUP FOR RAM HOLDERS

RAM diamond base with 1" ball for attaching to Ram Cradles or Twist Lock Suction Cup.

26-063K.....13.99

RAM Twist Lock Suction Cup. Attaches to RAM diamond base (#26-063).

26-065K.....24.99

NOTE:

• RAM twist lock suction cup mounts with the RAM diamond base only.



RAM BASE WITH 1" BALL

Replacement Base For Mounting Bracket. 1" diameter ball, connected at right angles to a flat 2.5" diameter base. The base has seven holes including the universal AMPS hole pattern.

26-057K.....14.99



RAM BASE WITH U-BOLT FOR HANDLEBAR

RAM-B-231 single u-bolt base for 3/4" to 1" rail with 1" ball size.

26-064K.....28.99



RAM CABLE MANAGER WITH AMPS HOLE PATTERN

The RAM Cable Manager creates an integrated route for electrical wiring and cleanly covers installation holes. A great addition to any surface mounting application. This item will work with any of the 2 5/8" round plates with AMPS hole pattern.

26-061K.....21.99



RAM DOUBLE 1" BALL ADAPTER

The RAM-B-230U, double ball joiner, consists of a 1" rubber ball on both ends that allow the connection of two 1" socket arms. When measured from ball center to ball center the arm length is 1.75". This mount is ideal if your mount arm is too short.

26-073K.....27.99



RAM EX-ROLL'R CRADLE FOR SPOT X

The form-fitting, high-strength composite RAM EZ-Roll'r cradle for the SPOT X allows for the attachment of RAM components containing the universal AMPS hole pattern. With the device in the cradle, all buttons and the power port remain fully accessible. The RAM EZ-Roll'r cradle for the SPOT X is compatible and interchangeable with a wide range of RAM diamond ball bases. Included is a set of two nuts and bolts.

26-820K.....18.99



RAM SELF-LEVELING CUP HOLDER WITH 1" BALL & COZY

A favorite world wide, the RAM self-leveling drink cup holder will bring a smile to anyone's face when they get it. The perfect accessory for any vehicle including motorcycles, ATV's, Big Rigs, and yes, even your prized riding lawn mower. Easily installed and positions to keep your favorite beverage within reach, this gem even comes with a RAM can insulator. Take a corner as hard as you like, this holder is ready to ride.

26-818K.....36.99



RAM CRADLE FOR SPOT GEN 4

The form-fitting, high-strength composite RAM EZ-Roll'r cradle for the SPOT Gen4 allows for the attachment of RAM components containing the universal AMPS hole pattern making it the ideal GPS mount for SPOT Gen4.

26-822K.....21.99



**Shop or Browse
Online 24/7
at
mercersmarine.com**



Fits
1 1/2"
Mount Only



RAM 5.625" ARM FOR 1.5" BALLS

The RAM-201U, Medium length double socket arm, has a socket at both ends that accommodates C Size 1.5" balls. A single spring inside the arm, keeps the socket open, allowing you to insert the ball in to the socket connection. RAM's socket technology allows for almost infinite adjustment to achieve the perfect viewing angle.
26-819K.....42.99



BACKROAD MAPBOOKS 2ND EDITION

The Backroad Mapbooks are Canada's bestselling outdoor recreation guidebooks for good reason. Our maps feature up to date logging road and industrial roads, trail systems and a wide range of recreational features that are not found on other maps. Add in the listings of everything from fishing lakes to Canadian paddling routes, from wilderness campsites to road side parks, from countless trails to wildlife viewing, and you will see the opportunities are endless.

26-884K.....Newfoundland & Labrador29.95



Fits 1 1/2"
Mount Only



RAM RAIL BASE MOUNT

The RAM motorcycle handlebar base contains a 1.5" rubber ball designed to sit at right angles to the mounting rail. The "Rust-Proof" stainless steel u-bolt accommodates rails in diameter from 0.5" to 1.25" in diameter. Included are black cover caps to be placed over the exposed ends of the u-bolt and a composite adapter that can narrow the rail to a minimum width of 0.5".
26-817K.....32.99



1 1/2"
Mount



RAM "FLAT SURFACE" UNIVERSAL MOUNT

The RAM-111 flat surface drill down mount consists of the 1.5 inch diameter ball and socket system with RAM universal rectangular 6.25 x 2 inch base. The rectangle base has many different combinations of pre-drilled holes which will match up to many electronic devices and mounts, including Marine GPS, CB Radios, Gimbal Brackets and more. Does fit handheld units.
26-539K.....96.99



Fits 1 1/2"
Mount Only



RAM 2.5" ROUND BASE WITH THE AMPS HOLE PATTERN & 1.5" BALL

The RAM-202U consists of a 1.5" diameter rubber ball connected to a flat 2.5" diameter base. This mount has pre-drilled holes, including the universal AMPS hole pattern.
26-074K.....24.99



RAM BACKING PLATE ADAPTER

3" x 3" steel backer plate with 10-24 threaded holes.
26-060K.....14.99



TOPOGRAPHIC MAPPING



GARMIN TOPO "CANADA-EAST" MAPPING

A Micro SD card with detail and precision, TOPO Canada - East, covers the finer details of the outdoors, including terrain contours, topo elevations, summits, routable roads and trails, rivers, lakes and geographical points. TOPO maps are ideal for hiking, hunting, camping, cycling and communing with nature. Coverage includes topographic detail of Quebec, Newfoundland, Labrador, Nova Scotia, Prince Edward Island and New Brunswick.

26-735J109.99



BACKROAD TOPO MAPS FOR NEWFOUNDLAND & LABRADOR - FOR GARMIN

Newfoundland & Labrador Backroad GPS at a Glance

- Combining day-to-day navigation with enhanced outdoor recreation information, this product combines all of Newfoundland and Labrador into one Backroad GPS Map.
- Over 38,000 km of our backroads network combined into one map, including over 20,000 km of routable roads.
- New mountain bike trail networks and Labrador railways.
- Marked Caribou Management Areas (CMA) and Moose Management Areas (MMA) for hunters.
- Address Search tool makes navigating easier than ever.
- Thousands of kilometres of ATV Trails, snowmobile routes, multi-use hiking, biking and cross-country skiing trails and paddling routes, with marked trailheads and access points/portages.
- Thousands of fishing hotspots, parks and conservation areas, campsites, hunting areas, winter recreation areas and more.
- Over 25,000 land and water geographic features.
- Enhanced cartography for improved display of parks, conservation areas, creeks and activity Points of Interest

26-880J69.99



BACKROAD TOPO MAPS, ATLANTIC CANADA - FOR GARMIN

Atlantic Canada Backroad GPS at a Glance:

- Combining day-to-day navigation with enhanced outdoor recreation information, this product combines all of Atlantic Canada into one Backroad GPS Map, from New Brunswick to Nova Scotia, Prince Edward Island, Newfoundland and Labrador.
- Over 310,000 km of our backroads network combined into one map, including over 110,000 km of routable roads.
- Labelled Crown Land for all of Nova Scotia and New Brunswick.
- Address Search makes navigating easier than ever.
- Marked Caribou Management Areas, Deer Management Zones, Moose Management Areas and Wildlife Management zones for hunters.
- Thousands of kilometres of ATV Trails, snowmobile routes, multi-use hiking, biking and cross-country skiing trails and paddling routes, with marked trailheads and access points/portages.
- Tens of thousands of fishing hotspots, parks and conservation areas, campsites, hunting areas, winter recreation areas and more.
- Over 62,000 land and water geographic features.
- Enhanced cartography for improved display of parks, conservation areas, Crown land, creeks and activity Points of Interest

26-882J99.99



TOPOGRAPHIC MAPPING

TOPO NEWFOUNDLAND AND LABRADOR 3 - FOR GARMIN HANDHELD GPS UNITS



Includes

- Complete coverage of Newfoundland and Labrador
- New Added the TransCanada Trail (The Great Trail) & T'Railway Trail
- New Added new moose & bear zones
- New Updated Provincial Protected Areas
- New Updated topography
- New Added points of interest
- New Additional tracks & trails
- 3D digital elevation model
- Hunting zones: caribou, moose & black bear
- Fishing zones: salmon rivers, trout zones
- Provincial Protected Areas
- Updated topographic data including forest zones, trails, mountains, hills, valleys, lakes, rivers, streams, swamps
- 17,500+ kilometres of forestry roads
- Contour lines, points of elevation and other terrain features
- Buildings, roads, electric lines, dams, railroads and other landmarks
- Wilderness, wildlife, and ecological reserves
- National and provincial parks
- Camping and picnic areas
- Thousands of POIs including gas stations, cellular towers, restaurants and lodging

26-737J69.99

TOPO & NLSF ATLANTIC CANADA 4 - FOR LOWRANCE HDS & ELITE/HOOK MODELS



Includes

- Complete coverage of New Brunswick, Nova Scotia, Prince Edward Island & Newfoundland & Labrador
- NEW Official NLSF snowmobile trails
- NEW Updated moose & bear zones
- NEW Points of interest
- Updated forest inventory
- Updated forestry trails and trailheads
- Province-wide topographic data including mountains, hills, valleys, lakes, rivers, forest zones and swamps
- Contour lines, points of elevation and other terrain features
- Buildings, roads, electric lines, dams, railroads, national parks and other landmarks
- Thousands of POIs including gas stations, cellular towers, camping & picnic areas, airports and more

26-567J69.99

www.mercersmarine.com





- Always Open
- Sale & Feature items
- View Catalogue



- Thousands of products
- Updated Regularly
- Up to date Pricing



- Mobile Friendly
- Shop from anywhere at anytime

Also find us on   

MARINE MAPPING



NAVIONICS + (CANADA & ALASKA)

Marine and lake charts. Get full marine coverage and more than 6,200 lakes and growing in Canada and Alaska, plus all of Puget Sound, Lake of the Woods, Rainy Lake and Canadian waters of the Great Lakes. Plug and play: Preloaded card with both Nautical Chart and SonarChart.

View detailed shorelines with marinas, docks and boat ramp locations. Increase your awareness of shallow waters and hazardous areas at any depth level including shoals, rocks, wrecks and more. Target underwater structure with up to 1 ft HD contours to find the best fishing locations: roadbeds, foundations, bridges, brush piles, culverts and creek channels. Consult tides and currents to plan your boating activities.

26-056JCanada & Alaska195.99



NAVIONICS + (CANADA & U.S.A)

For use with Lowrance & Eagle GPS units. •Get marine areas and a growing list of more than 18,000 lakes in US and Canada all on one card. Plug and play: Preloaded card with Nautical Chart. View detailed shorelines with marinas, docks and boat ramp locations. Increase your awareness of shallow waters and hazardous areas at any depth level including shoals, rocks, wrecks and more. Target underwater structure with up to 1 ft HD contours to find the best fishing locations: roadbeds, foundations, bridges, brush piles, culverts and creek channels. Consult tides and currents to plan your boating activities.

26-054JCanada/U.S.A349.99



NAVIONICS + (CANADA NORTH)

Coverage of northern, coastal, and inland Canada, including the Northwest Territories, Nunavut and northern Quebec. Includes major bodies of water such as Hudson Bay, Hudson Strait, Northwestern passage, and inland lakes.

26-055JCanada North189.99

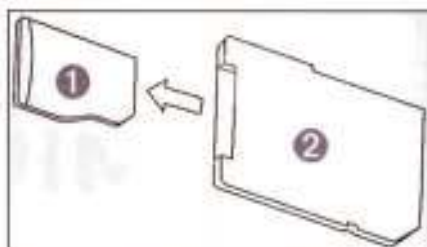

PLEASE NOTE :

To Remove a microSD Card

If your GPS device uses the smaller microSD card (See image 1) instead of the larger SD adapter (See image 2) remove the microSD card from the adapter according to the illustration

MARINE MAPPING



GARMIN NAVIONICS + CAN/ALASKA

For offshore or inland waters, this all-in-one solution offers detail-rich integrated mapping of coastal waters, lakes, rivers, and more. The Navionics Chart Installer software also ensures the freshest chart data every time out. Multiple shading options aid in shallow water navigation and make it easy to highlight a target depth range for the best fishing spots.

26-403J199.99

GARMIN NAVIONICS VISION + CAN/ALASKA

The Premium map option for your compatible Garmin display. Inclusive of both inland lakes and coastal waters, data is sourced from both Garmin and Navionics to provide you with exceptional detail. Premium features include High Resolution Relief Shading, High Resolution Satellite Imagery, Sonar Imagery, Aerial Photography, SideScan Images and more!

26-404J329.99



GARMIN NAVIONICS + CANADA NORTH

Featuring vibrant colors, a streamlined interface and combined coastal/inland content with a popular Navionics style color palette, Garmin Navionics+ cartography makes it easy to plot your course with the world's No. 1 name in marine mapping.

26-405J189.99



GARMIN BLUECHART G3 "CANADA"

Industry-leading coverage, clarity and detail with new charts that feature integrated Garmin and Navionics content. Auto Guidance¹ quickly calculates a suggested route by using your desired depth and overhead clearance. Includes Depth Range Shading for up to 10 depth ranges, enabling you to view your target depth at a glance. Up to 30 cm (1 ft) contours provide a more accurate depiction of the bottom structure for improved fishing charts. To give a clear picture of shallow waters to avoid, the Shallow Water Shading feature allows for shading at a user-defined depth. Experience unparalleled coverage and brilliant detail when you're on the water. BlueChart g3 coastal charts provide industry-leading coverage, clarity and detail with integrated Garmin and Navionics content.

26-400JCanada279.99



ROAD MAPPING - AUTO



GARMIN CITY NAVIGATOR (NORTH AMERICA)

Navigate the streets with confidence. This product provides detailed road maps and points of interest for your device, so you can navigate with exact, turn-by-turn directions to any address or intersection. Displays millions of points of interest, including hotels, restaurants, parking, entertainment, fuel and shopping. Includes postal code support for Canada. Gives turn-by-turn directions on compatible devices. Speaks street names (example: "Turn right on Main Street!"). Includes navigational features, such as turn restrictions, roundabout guidance and speed categories. Contains traffic data for compatible devices with traffic receivers.

26-734J129.99





GARMIN "STRIKER PLUS 4" FISHFINDER

4" GPS Fishfinder with Industry-leading Sonar and Quickdraw Contours Mapping Software.

- Includes dual-beam transducer with Garmin CHIRP traditional sonar for crystal-clear images and remarkable target separation.
- Built-in Garmin Quickdraw Contours mapping software lets you create and store maps with 1' contours for up to 2 million acres.
- Built-in GPS lets you mark waypoints, create routes and view boat's speed.
- Bright, sunlight-readable 4.3" display and intuitive user interface.
- Rugged design for every fishing environment.



↗ 4.3"

With Dual Beam Transducer (4 pin)

- Maximum Depth : 750 ft.
 Unit reads in feet, fathoms, or meters.
 -Unit dimensions : 3.9" x 6.9" x 1.8"
 -Display size : 4.3" diagonal
 -Display resolution : 272 x 480 pixels
 -Waterproof (IPX7)
 -Comes with Transducer

26-924JStriker 4 Plus Fishfinder219.99
26-596JCover19.99
26-755J10' Transducer Ext. Cable47.99

For more information please visit www.mercersmarine.com.



GARMIN "STRIKER 4" PORTABLE FISHFINDER

3.5-inch CHIRP Fishfinder with GPS and Portable Kit.

- Easy-to-use 3.5-inch color fishfinder with built-in, high-sensitivity GPS.
- Portable carrying case is perfect for kayak, canoe or ice fishing.
- Find fish; mark and return to hot spots, docks and ramps.
- Includes CHIRP (77/200 kHz) sonar transducer; transmit power (200 W RMS)/(1,600 W peak-to-peak).
- Share your favorite waypoints and routes with other STRIKER and echoMAP chartplotter combos.
- Includes carrying case, rechargeable battery.



↗ 3.5"

With Dual Beam Transducer (4 pin)

- Maximum Depth : 750 ft.
 Unit reads in feet, fathoms, or meters.
 -Unit dimensions : 3.6" x 5.9" x 1.6"
 -Display size : 3.5" diagonal
 -Display resolution : 480 x 320 pixels
 -Waterproof (IPX7)
 -Comes with Transducer

26-783JStriker 4 portable Fishfinder299.99
---------	------------------------------------	-------------

GARMIN PORTABLE FISHING KIT

Take Your Fishfinder Anywhere

- Perfect for kayaking, canoeing, johnboating, docking or ice fishing
- Rugged, portable bag protects and carries your fishfinder
- Base with built-in rigid handle
- Suction cup transducer mount and foam float
- Rechargeable battery and smart charger
- Fishfinder NOT included in kit. Fishfinder sold separately.



Fishfinder sold separately



It's easy to take along your compatible STRIKER fishfinder with GPS or echoMAP and echoMAP CHIRP combos with this portable kit. It protects and carries your fishfinder and includes a sealed, rechargeable battery with smart charger, built-in transducer cable management and storage and suction cup transducer mount and float. When using the portable kit in a kayak, the optional kayak in-hull transducer mount secures your Garmin dual beam transducer (77/200 kHz), CHIRP (77/200 kHz) or GT20-TM transducer (77/200 kHz/ClearVu) to the kayak. This mount can withstand continuous water submersion without releasing, all while protecting your transducer within the kayak.

26-768JPortable Fishing Kit119.99
---------	---------------------------	-------------

GARMIN "STRIKER VIVID 5CV" FISHFINDER

See fish and structure in maximum detail when you pick your display color, your location and your sonar for your day on the water with the STRIKER Vivid 5cv fishfinder with transducer.

- Choose from 7 new vivid color options to see fish and structure in maximum contrast and clarity on your 5" fishfinder.
- Use the included GT20 transducer to get Garmin CHIRP traditional sonar and CHIRP ClearVü scanning sonar.
- To catch more fish, you need to know where the fish are biting. Use waypoint marking for hot spots so you can easily find your way back.
- Plan and create routes and view your boat's speed on your fishfinder using high-sensitivity GPS.
- Nobody knows the waters you fish better than you. With the STRIKER Vivid 5cv fishfinder, you can store up to 2 million acres of maps with 1' contours.
- The STRIKER Vivid 5cv fishfinder includes a tilt/swivel mount plus transom and trolling motor mounting hardware and cable.

Maximum Depth : 900 ft.

Unit reads in feet, fathoms, or meters.

26-922J	Striker Vivid 5CV Fishfinder	429.99
26-593J	Cover	26.99
26-755J	10' Transducer Ext. Cable	47.99



With GT20 Transducer (4 pin)

GARMIN "STRIKER VIVID 7CV" FISHFINDER

See fish and structure in maximum detail when you pick your display color, your location and your sonar for your day on the water with the STRIKER Vivid 7cv fishfinder with transducer.

- Choose from 7 new vivid color options to see fish and structure in maximum contrast and clarity on your 7" fishfinder.
- Use the included GT20 transducer to get Garmin CHIRP traditional sonar and CHIRP ClearVü scanning sonar.
- To catch more fish, you need to know where the fish are biting. Use waypoint marking for hot spots so you can easily find your way back.
- Plan and create routes and view your boat's speed on your fishfinder using high-sensitivity GPS.
- Nobody knows the waters you fish better than you. With the STRIKER Vivid 7cv fishfinder, you can store up to 2 million acres of maps with 1' contours.
- Connect to the ActiveCaptain® app1 to transfer waypoints, receive smart notifications (including software update notifications) and access the Garmin Quickdraw™ Community.
- The STRIKER Vivid 7cv fishfinder includes a tilt/swivel mount plus transom and trolling motor mounting hardware and cable.

Maximum Depth : 900 ft.

Unit reads in feet, fathoms, or meters.

26-923J	Striker Vivid 7CV Fishfinder	569.99
26-594J	Cover	26.99
26-755J	10' Transducer Ext. Cable	47.99



With GT20 Transducer (4 pin)





Marine Map & Transducer Included

Marine Map & Transducer Included

5" With GT20 Transducer (4 pin)

7" With GT20 Transducer (4 pin)

26-913JEchomap UHD2 55CV669.99
26-592JCover28.99
26-755J10' Transducer Ext. Cable47.99

26-914JEchomap UHD2 75CV939.99
26-597JCover28.99
26-755J10' Transducer Ext. Cable47.99

GARMIN ECHOMAP UHD2 55CV & 75CV GPS/SOUNDER WITH MARINE MAPPING

They say locals know best. But anyone who says that hasn't fished with the ECHOMAP UHD2 5" and 7" chartplotters with clear, crisp sonar and mapping.

- With crisp, clear traditional sonar and brilliant ClearVü sonar, the fish will have nowhere to hide.
- High-contrast vivid scanning sonar color palettes make it easier than ever to distinguish targets and structure.
- Your ECHOMAP UHD2 device supports a variety of Garmin transducers for two types of sonar: Garmin traditional and ClearVü scanning sonars.
- Know the waters you're in as if you grew up fishing them by using built-in Garmin Navionics+ coastal or inland mapping which includes a 1-year subscription for downloadable daily updates and more.
- If you have another compatible ECHOMAP UHD2 chartplotter on your boat, the 5" and 7" models can wirelessly share information, such as sonar, waypoints and routes.
- Built-in Wi-Fi connectivity pairs with the free all-in-one mobile app for access to the OneChart feature, software updates, Garmin Quickdraw Community data and more.
- Transducer Included. Maximum 900 ft. Depth.



6" Marine Map & Transducer Included With GT54 Transducer (12 pin)

7" Marine Map & Transducer Included With GT54 Transducer (12 pin)

9" Marine Map & Transducer Included With GT56 Transducer (12 pin)

26-915JEchomap UHD2 65SV1259.99
26-159J10' Transducer Ext. Cable58.99

26-916JEchomap UHD2 75SV1469.99
26-159J10' Transducer Ext. Cable58.99

26-917JEchomap UHD2 95SV1799.99
26-159J10' Transducer Ext. Cable58.99

GARMIN ECHOMAP UHD2 65SV, 75SV, & 95SV GPS/SOUNDER WITH MARINE MAPPING

- The bright 6", 7" or 9" touchscreen display with keyed-assist is user-friendly and easy to read.
- With crisp, clear traditional sonar and brilliant ClearVü and SideVü scanning sonars, the fish will have nowhere to hide. Your ECHOMAP UHD2 also supports LiveScope live-scanning sonar.
- High-contrast vivid scanning sonar color palettes make it easier than ever to distinguish targets and structure.
- Your ECHOMAP UHD2 device supports a variety of Garmin transducers. The 6" and 7" chartplotters come bundled with a GT54 transducer, while the 9" chartplotter comes with a GT56 transducer.
- Comes with built-in Garmin Navionics+ mapping.
- If you have another compatible ECHOMAP UHD2 chartplotter on your boat, you can wirelessly share information, such as sonar, waypoints and routes.
- Built-in Wi-Fi connectivity pairs with the free all-in-one mobile app on your compatible smartphone for access to the OneChart feature, smart notifications, software updates, Garmin Quickdraw Community data and more.
- Chartplotters with built-in Garmin Navionics+ charts include downloadable Auto Guidance+ technology with the ActiveCaptain app.
- Your ECHOMAP UHD2 wirelessly connects to your Force trolling motor to create and follow routes, navigate to waypoints, control speed, check battery life and more.
- Get improved position accuracy, particularly in areas where signals are reflected or weak, with multi-band GPS.
- Transducer Included. Maximum 900 ft. Depth.



12 Pin

26-937JGPSMAP 723XSV1619.99

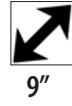

12 Pin

26-929JGPSMAP 923XSV2019.99

GARMIN GPSMAP 723XSV & 923XSV GPS/SOUNDER

With its sleek design, powerful processing and upgraded IPS display, this advanced 7" or 9" chartplotter integrates seamlessly into your Garmin marine system.

- Get built-in Ultra High-Definition SideVü and ClearVü scanning sonars with vivid, high-contrast color palettes to help distinguish fish from structure. GPSMAP X3 series also supports 1 kW CHIRP traditional sonar capabilities.
- Pair with Panoptix or LiveScope easy-to-interpret live sonar (transducer required, sold separately) to see all around your boat in real time.
- With its added processing power and slimline design featuring edge-to-edge glass, it's easy to retrofit this plotter in a wider range of dash configurations.
- New higher-resolution IPS display plotters offer improved sunlight readability and visibility from any angle.
- To help you avoid weather and traffic on the water, the compact 4 kW GMR 18 HD+ dome radar is available as a bundled option.
- View laylines, race start line guidance, enhanced wind rose, heading and course-over-ground lines, true wind data fields and tide/current/time slider, wind angle, set and drift, wind speed, polars and more.
- Use the polar table to see key data, including how fast you should go at a certain wind angle and speed.
- If you have multiple compatible Garmin devices on your boat, you can share information, such as maps, user data, radar and IP camera video.
- Connect to compatible autopilots, digital switching, weather, Fusion-Link audio system, media, VHF, AIS and more from one screen.
- Built-in Wi-Fi connectivity pairs with the free all-in-one mobile app for access to the OneChart feature, smart notifications, software updates, Helm, Garmin Quickdraw Community data and more.
- TRANSDUCER SOLD SEPERATELY. Maximun 2700 ft with optional 1kw transducer.**
- MAPPING SOLD SEPERATELY.**



12 Pin

26-944JGPSMAP 1022XSV2019.99



12 Pin

26-946JGPSMAP 1222XSV2969.99

GARMIN GPSMAP 1022XSV & 1222XSV GPS/SOUNDER

These chartplotters feature large, bright screens coupled with quick and easy-to-use keypad interfaces with user-programmable keys and multifunction control knobs to help you navigate with ease.

- Get wider viewing angles on a vivid 10" or 12" color display.
- The chartplotters include built-in single-channel CHIRP sonar plus CHIRP ClearVü and CHIRP SideVü scanning sonars with Panoptix and LiveScope sonar support on
- Enjoy built-in ANT wireless connectivity directly to your compatible Garmin devices.
- Built in Wi-Fi technology gives you access to the free all-in-one ActiveCaptain app.
- Use the polar table to view important data fields to help you trim your sails for maximum speed and efficiency. You can also see laylines, set and drift, true and apparent wind data (sensor sold separately), and more.
- The fast, responsive built-in 10 Hz GPS and GLONASS receiver refreshes your position and heading 10 times each second to make your movement on the screen more fluid.
- The GPSMAP chartplotters are fully network capable for the Garmin Marine Network and NMEA 2000 networking plus NMEA 0183 technology support.
- Easily transfer waypoints, tracks or frequently used routes from other devices via industry standard GPX software formatting.
- Garmin Marine Network support allows sharing of sonar, maps, user data, dome or open-array radar, and Panoptix and LiveScope sonars among multiple units.
- Read RPMs, fuel flow, temperature, trim and other important information at a glance. Check with your engine manufacturer for additional hardware needs.
- TRANSDUCER SOLD SEPERATELY. Maximun 2700 ft with optional 1kw transducer.**
- MAPPING SOLD SEPERATELY.**



12 Pin
26-948JGPSMAP 8410XSV3639.99

GARMIN GPSMAP 8410XSV GPS/SOUNDER - TOUCHSCREEN

10" Touchscreen Chartplotter/Sonar Combo with Full HD In-plane Switching (IPS) Display.

Serious sport fishermen, cruisers, sailors and sail racers demand serious equipment. The easy-to-use, easy-to-install GPSMAP 8410xsv chartplotter/sonar combo delivers MFD performance in a combo-size package. It features a 10" full HD in IPS touchscreen display for wider viewing angles, superior clarity and sunlight readability, even with polarized sunglasses. Multiple displays can be flat mounted edge-to-edge to create a sleek glass helm look or can be mounted flush. Supports optional BlueChart g3 Vision HD charts for Auto Guidance and other premium navigation features.

- Features a 10" full HD IPS touchscreen display
 - Built-in support for the full suite of Garmin sonar capabilities
 - Fully network capable with NMEA 2000 connectivity and the Garmin Marine Network
 - Includes ANT technology and Wi-Fi networking
 - SmartMode station controls enable quick, one-touch access to the information you need
- For more information please visit www.mercersmarine.com
- MAPPING & TRANSDUCER SOLD SEPERATELY. Maximun 5000 ft. Depth with optional 1kw transducer.



12 Pin
26-947JGPSMAP 8612XSV5534.99

GARMIN GPSMAP 8612XSV GPS/SOUNDER - TOUCHSCREEN

•Large 12" display offers wider viewing angles, superior clarity and sunlight readability, even with polarized sunglasses.
 •You can install multiple displays, either flat mounted edge-to-edge for a sleek glass helm look or mounted flush.
 •Get built-in support for 1-kW CHIRP traditional sonar for superior target separation and ClearVü and SideVü scanning sonars to see up to 1,000' below and around your boat at 260 kHz (transducer sold separately).
 •Pair your chartplotter with Panoptix or Panoptix LiveScope easy-to-interpret live sonar (transducer sold separately) to see all around your boat in real time.

- If you have multiple Garmin devices on your boat, you can share information.
 - Connect to autopilots, digital switching, weather, Fusion-Link audio system, media, VHF, AIS and more.
 - Built-in Wi-Fi connectivity pairs with the free all-in-one mobile app for access to the OneChart feature, smart notifications, software updates, Garmin Quickdraw Community data and more.
 - Connect with some of your favorite devices, such as quatix marine watches, and wireless remote controls.
- MAPPING & TRANSDUCER SOLD SEPERATELY. Maximun 5000 ft. Depth with optional 1kw transducer.

Garmin optional transducers, cables, & accessories

Garmin 8 pin Transducers

26-141J.....	GT15M In-Hull.....	249.99
26-146J.....	Stern Mount 50/200.....	109.99
26-145J.....	Airmar P66 50/200.....	229.99
26-163J.....	GT23M-TM (Chirp).....	269.99
26-138J.....	GT15M-TM (Chirp).....	249.99
26-127J.....	P319 Plastic Thru-Hull.....	219.99
26-130J.....	B117 Bronze Thru-Hull.....	339.99
26-133J.....	GT15M Bronze Thru-Hull.....	379.99
26-132J.....	SS60 0 degree Tilt.....	529.99
26-134J.....	SS60 12 degree Tilt.....	529.99
26-143J.....	B744V Bronze Thru-Hull.....	569.99
26-149J.....	B258 (1kw) Bronze Thru-Hull.....	1099.99

See page 222 for Transducer Information.

Garmin 8 pin Cables

26-158J.....	10' Extension Cable 8 pin.....	58.99
26-751J.....	8 pin Trans. to 12 pin Sounder.....	32.99

Garmin 12 pin Transducers

26-160J.....	GT52 HW-TM.....	389.99
26-157J.....	GT54 UHD-TM.....	439.99
26-156J.....	GT56 UHD-TM.....	569.99
26-161J.....	GT51M-TM.....	769.99

Garmin 12 pin Cables

26-159J.....	10' Extension Cable 12 pin.....	58.99
--------------	---------------------------------	-------

Garmin Optional Antenna

Garmin GPS24XD NMEA 2000 Antenna		
26-413J.....	449.99

Garmin NMEA Starter Kit

26-408J.....	129.99
--------------	-------	--------

**SHOP 24/7 FROM
THE COMFORT OF
YOUR OWN HOME**

- Up to date Pricing
- New Products
- Stock Status
- Additional product info
- And more



www.mercersmarine.com

GARMIN



12 Pin

12"

26-945JGPSMAP 1223XSV4049.99

GARMIN GPSMAP 1223XSV GPS/SOUNDER - TOUCHSCREEN

- Get built-in Ultra High-Definition SideVü and ClearVü scanning sonars with vivid, high-contrast color palettes to help distinguish fish from structure. GPSMAP X3 series also supports 1 kW CHIRP traditional sonar capabilities.
- Pair with Panoptix or LiveScope easy-to-interpret live sonar (transducer required, sold separately) to see all around your boat in real time.
- High resolution IPS displays offer improved sunlight readability and visibility from any angle.
- View laylines, race start line guidance, enhanced wind rose, heading and course-over-ground lines, true wind data fields and tide/current/time slider, wind angle, set and drift, wind speed, polars and more.
- Use the polar table to see key data, including how fast you should go at a certain wind angle and speed.
- If you have multiple compatible Garmin devices on your boat, you can share information.
- Connect to compatible autopilots, digital switching, weather, Fusion-Link audio system, media, VHF, AIS and more.
- Built-in Wi-Fi connectivity pairs with the free all-in-one mobile app for access to the OneChart feature, smart notifications, software updates, Helm, Garmin Quickdraw Community data and more.
- Connect with some of your favorite devices, such as quatix marine watches and wireless remote controls.
- MAPPING & TRANSDUCER SOLD SEPERATELY. Maximun 5000 ft. Depth with optional 1kw transducer.**

GARMIN



26-951JAIS 8001299.99

GARMIN AIS 800 BLACKBOX TRANSCEIVER

Help Avoid Running into Trouble on the Water

- Easy-to-use, reliable communication transmits your vessel information to other AIS receivers in your area while receiving AIS target data
- 5 watts of transmit power with Class B/S0 provides faster positioning reporting than ever before¹
- Built-in GPS with connector for optional external antenna
- NMEA 2000® connectivity for easy integration with compatible chartplotters and multifunction displays
- Internal VHF antenna splitter allows VHF and AIS to share a single antenna

Increase your situational awareness and confidence on the water with the Garmin AIS 800 transceiver. It has 5 watts of transmit power and provides faster position reporting than ever before¹. It transmits your vessel information to other AIS receivers in your area while it receives their AIS target data. Garmin AIS 800 has an internal VHF antenna splitter, which allows the VHF and AIS to share a single antenna. It includes a built-in GPS (with connector for optional external antenna) and integrates seamlessly into the Garmin onboard system. The transceiver features NMEA 2000/0183 connectivity for easy integration with compatible chartplotters and multifunction displays. And it's all packed into an easy-to-install black box unit with a small footprint.

GARMIN "GMR 18HD+" 4KW/36NM RADAR

Streamlined 18-inch 4 kW dome radar. Delivers 4 kW transmit power and clear echo definition at all ranges. Dynamic Auto Gain automatically adjusts to your surroundings for optimal performance in all conditions. Dynamic Sea Filter automatically adjusts gain to changing sea conditions. Overlays radar image on the chartplotter map page (autopilot or heading sensor recommended for best results).

Dynamic Auto Gain automatically adjusts to your surroundings for optimal performance in all conditions. Dynamic Sea Filter automatically adjusts sea clutter, depending on sea conditions. GMR 18 HD+ features 8-bit true color resolution for a clear presentation on your chartplotter screen. It has a maximum range of 36 nautical miles with a minimum range of 20 meters and a rotation speed of 24 RPM. There are no complex user settings, and it's easy to install and start using.

Can use with any network compatible Garmin GPSMAP Series

26-832J2299.99

GARMIN "GMR18XHD" 4KW/48NM RADAR

Next-generation, 4 kW high-definition GMR 18 xHD dome radar pairs ease of use with advanced open-array features. Its intuitive operation makes modes and settings simple to understand so you can enjoy great performance without a lot of technical know-how. The GMR 18 xHD delivers higher resolution than our previous generation 18" dome radars. New Dynamic Auto Gain and Dynamic Sea Filter continually adjust to your surroundings, providing optimal performance in varying conditions. Choose from multiple levels of aggressiveness or use manual gain adjustment. Dual range operation allows fully independent split-screen display of far and close radar views in full 8-bit color (select chartplotters); range of 48 nm. Optional "No Transmit Zone" can protect areas behind the radar from being radiated while providing full forward-looking radar capability. This makes installation more flexible by providing more suitable installation options on your boat.

Can use with any network compatible Garmin GPSMAP Series

26-834J2599.99



LOWRANCE HOOK REVEAL

All units come with  C-MAP

GPS/Sounders

NEW



50/200 Transducer Included

NEW



50/200 Transducer Included

NEW



50/200 Transducer Included

Hook Reveal 5

26-626JHook Reveal 5859.99
26-551JCover36.99

Hook Reveal 7

26-628JHook Reveal 71249.99
26-553JCover36.99

Hook Reveal 9

26-630JHook Reveal 91429.99
26-566JCover43.99

LOWRANCE HOOK REVEAL GPS/FISHFINDERS COMBINATION UNITS

The all-new HOOK Reveal makes fishing easier, delivering powerful performance with proven fish-finding tools including, Autotuning Sonar, DownScan Imaging™ and now FishReveal™, which makes fish easier to see by combining the benefits of Lowrance CHIRP sonar and DownScan Imaging™ on one screen. Whether you're fishing a local spot or unfamiliar water, find the best fishing areas with included US/Canada C-MAP® Contour™+ mapping or map uncharted water – in real time – with Genesis Live.

Key Features

- FishReveal™
- Genesis Live Real-Time Mapping
- Autotuning sonar
- 50/200 HDI transducer with Low/High CHIRP and DownScan Imaging™
- Includes C-MAP® Contour+ inland and coastal charts with high resolution, bathymetric 1-foot contours on 15,000+ U.S. Lakes and 9,400+ lakes in Canada
- SolarMAX™ Display
- New fish-finding color palettes
- Optimized keypad with one-touch access to key features
- Mapping options include C-MAP, C-MAP Genesis, Navionics® and more
- microSD card slot
- Easy front-dash or gimbal-bracket mount
- Improved sonar performance in deep water

LOWRANCE HOOK REVEAL ACCESSORIES

26-570JBracket for Hook Reveal 526.99
26-562JBracket for Hook Reveal 752.99
26-571JBracket for Hook Reveal 959.99
26-254JPower Cord for Hook Reveal26.99
26-620JHook Reveal 50/200 Transducer389.99
26-137J10' Transducer Ext. Cable69.99
26-551JHook Reveal 5" Sun Cover36.99
26-553JHook Reveal 7" Sun Cover36.99
26-566JHook Reveal 9" Sun Cover43.99

Other Features

- Reads in feet, fathoms, or meters.
- Units come with Transducer
- Comes with internal antenna



www.mercersmarine.com

- Always Open
- Sale & Feature items
- View Catalogue
- Thousands of products
- Updated Regularly
- Up to date Pricing
- Mobile Friendly
- Shop from anywhere at anytime

find us on   

GPS ELECTRONICS

Prices are subject to change. Check our website for up to date prices. www.mercersmarine.com

LOWRANCE ELITE FS

Comes with built in **C-MAP**

NEW



LOWRANCE ELITE FS 7 ,WITH CMAP
26-651J1189.99

NEW

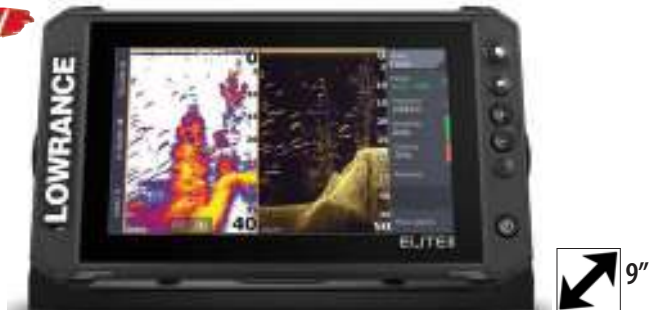

LOWRANCE ELITE FS 9 ,WITH CMAP
26-652J1599.99

BOTH MODELS ABOVE COME WITHOUT TRANSDUCER. SEE LIST OF COMPATIBLE TRANSDUCERS BELOW

LOWRANCE ELITE FS GPS/FISHFINDERS WITH CMAP

The new Elite Fishing System (FS) gives you access to the full line-up of Lowrance fishfinding tools – including ActiveTarget™ Live Sonar, Active Imaging™ and preloaded C-MAP Contour+ charts – to help you make the most of your time on the water. All the above Elite FS models above come without Transducer. See list of compatible transducers below.

Key features

- ActiveTarget™ Live Sonar ready
- Active Imaging 3-in-1 ready
- FishReveal™
- Preloaded C-MAP® Contour+ inland and coastal charts with high resolution, bathymetric 1-foot contours on 15,000+ U.S. Lakes and 9,400+ lakes in Canada
- Mapping options including C-MAP, Navionics® and more
- C-MAP® Easy Routing, Navionics® Autorouting capability
- C-MAP Genesis Live onscreen mapping
- High-resolution multi-touch touchscreen
- Integrated wireless, NMEA 2000® and Ethernet connectivity
- Full touchscreen control of Power Pole® anchors and Ghost® Trolling Motor

TRANSDUCERS (9 PIN BLACK)

26-601J.....HDI 9 pin Transducer.....	199.99
26-611J.....P66 9-Pin Transducer	279.99
26-618J....Active Imaging 3 in 1 Trans. (9 pin) ..	519.99
26-610J.....P319 Plastic Thru-Hull.....	299.99
26-612J.....B45 Bronze Thru-Hull	399.99
26-613J.....SS60 S.S. Thru-Hull - 0 Deg.....	699.99
26-616J.....SS60 9-Pin Thru-Hull - 12 Deg.....	699.99
26-615J.....B258 (1kW) Bronze Thru-Hull	1429.99
26-609J.....P79 Plastic In-Hull	219.99

Other Features

- Reads in feet, fathoms, or meters.
- Comes with internal antenna

OPTIONAL ADAPTOR CABLES

7 TO 9 PIN ADAPTOR CABLE
CONNECTS 7 PIN BLUE TRANSDUCER TO THE 9 PIN BLACK DISPLAY

26-603J	52.99
---------------	-------

10' 9-Pin Transducer Extension Cable

26-166J	122.99
---------------	--------

Adaptor cable connects 9 pin transducer to 7 pin Sounder

26-608J	62.99
---------------	-------

LOWRANCE ELITE FS ACCESSORIES

26-255J.....Power cable for Elite FS.....	56.99
26-568J.....Bracket for Elite FS-7	52.99
26-569J.....Bracket for Elite FS-9.....	59.99

See page 224 for Transducer Information.

NEW



DIELECTRIC SILICONE COMPOUND

An excellent lubricant and sealant that prevents corrosion and reduces short circuits resulting from water intrusion. Fights oxidation to improve conductivity. Penetrates aluminum oxide to maintain current paths.

28-097K	9.5 g.....	12.95
---------------	------------	-------



LOWRANCE HALO 20 RADAR - 24NM

Improve your situational awareness and collision avoidance with HALO20, a compact dome radar with pulse compression technology that detects collision hazards and other targets in close and up to 24 nautical miles away. With its small footprint and low profile, HALO20 is a great radar for boaters with small sportfishing vessels and dayboats.

26-840J	2989.99
---------------	---------



LOWRANCE HALO 20+ RADAR - 36NM

Get an almost real-time view with HALO20+. Industry-leading 60 RPM operation at close range provides the best in collision avoidance. Identify hazards instantly with VelocityTrack™ Doppler technology, and enjoy both short and long-range coverage—up to 36 nautical miles—from a compact 20-inch dome antenna.

26-842J	3699.99
---------------	---------

LOWRANCE HDSLIVE

Comes with built in **C-MAP**



7"



9"



12"

26-900J.....HDS 7 Live.....**1999.99**
7", LED-backlit, multi-touch, widescreen display.
5000 ft. Depending on Transducer.

26-902J.....HDS 9 Live.....**2899.99**
9", LED-backlit, multi-touch, widescreen display.
5000 ft. Depending on Transducer.

26-904J.....HDS 12 Live.....**4899.99**
12", LED-backlit, multi-touch, widescreen display.
5000 ft. Depending on Transducer.

ALL 3 MODELS ABOVE COME WITHOUT TRANSDUCER. SEE LIST OF COMPATIBLE TRANSDUCERS BELOW

LOWRANCE HDS LIVE SERIES GPS/FISHFINDERS COMBINATION UNITS

Prepare yourself for a new level of fishfinding performance with HDS LIVE, which includes built-in Lowrance CHIRP sonar, support for Active Imaging, StructureScan 3D with Active Imaging and the new ActiveTarget Live Sonar. Equipped with the best set of navigation tools ever built into a fishfinder/chartplotter display, HDS LIVE features preloaded C-MAP US Enhanced Inland and Coastal mapping, automatic routing support and new Genesis Live onscreen mapping offering precision real-time mapping, down to 1/2-foot contours. All HDS Live come without Transducer. See list of compatible transducers below.

Key features

- SolarMAX HD Screen Technology
- Built-in Low, Medium and High CHIRP
- Integrated support for New Active Imaging and StructureScan 3D with Active Imaging.
- LiveSight real-time sonar compatible
- FishReveal Smart Target View
- HALO24 Radar ready
- C-MAP Genesis Live mapping
- Preloaded C-MAP US Enhanced Mapping
- Smartphone notifications
- LiveCast smartphone integration (HDS LIVE 12 only)
- C-MAP Easy Routing + Navionics Autorouting capability
- Six-panel splitscreen (HDS LIVE 12 ONLY)
- Touchscreen control of trolling motor, outboard pilot and Power-Pole
- SonicHub2 and SiriusXM Marine Weather/Audio ready
- Broadband Radar compatible
- Sleek, low-profile design

Other Features

- Reads in feet, fathoms, or meters.
- Comes with internal antenna

See page 222 for Transducer Information.

TRANSDUCERS (9 PIN BLACK)

26-601J.....HDI 9 pin Transducer.....	199.99
26-611J.....P66 9-Pin Transducer	279.99
26-618J....Active Imaging 3 in 1 Trans. (9 pin) ..	519.99
26-610J.....P319 Plastic Thru-Hull.....	299.99
26-612J.....B45 Bronze Thru-Hull	399.99
26-613J.....SS60 S.S. Thru-Hull - 0 Deg.....	699.99
26-616J.....SS60 9-Pin Thru-Hull - 12 Deg.....	699.99
26-615J.....B258 (1kW) Bronze Thru-Hull	1429.99
26-609J.....P79 Plastic In-Hull	219.99

LOWRANCE HDS LIVE ACCESSORIES

26-255J.....Power cable for HDS Live	56.99
26-568J.....Bracket for HDS-7 Live	52.99
26-569J.....Bracket for HDS-9 Live	59.99

OPTIONAL ADAPTOR CABLES

7 TO 9 PIN ADAPTOR CABLE	
CONNECTS 7 PIN BLUE TRANSDUCER TO THE 9 PIN BLACK DISPLAY	
26-603J	52.99
10' 9-Pin Transducer Extension Cable	
26-166J	122.99
Adaptor cable connects 9 pin transducer to 7 pin Sounder	
26-608J	62.99



LOWRANCE HALO 20 RADAR - 24NM

Improve your situational awareness and collision avoidance with HALO20, a compact dome radar with pulse compression technology that detects collision hazards and other targets in close and up to 24 nautical miles away. With its small footprint and low profile, HALO20 is a great radar for boaters with small sportfishing vessels and dayboats.

26-840J	2989.99
---------------	----------------



LOWRANCE HALO 20+ RADAR - 36NM

Get an almost real-time view with HALO20+. Industry-leading 60 RPM operation at close range provides the best in collision avoidance. Identify hazards instantly with VelocityTrack™ Doppler technology, and enjoy both short and long-range coverage—up to 36 nautical miles—from a compact 20-inch dome antenna.

26-842J	3699.99
---------------	----------------

SIMRAD



Note: If purchasing a 9 pin transducer, you must also purchase a 26-608 adaptor

SIMRAD S2009 FISHFINDER

The Simrad S2009 Fish Finder combines CHIRP-enabled Broadband Sounder™ sonar with a 9-inch portrait display for maximum vertical detail, and intuitive keypad-driven operation for reliable control in all conditions. This dedicated echosounder integrates seamlessly with multifunction display and Simrad glass bridge systems, while offering charter captains and long-range sportfishing vessels the reliability of a self-contained sonar platform. Robust yet compact, the S2009 supports either bracket or flush-mount installation for an easy fit aboard any vessel. **Comes WITHOUT Transducer.** (7 pin blue). **Reads up to 10000 ft with 1kw transducer and S5100 Sonar Module.** Please inquire for more info.

26-890JSimrad S2009 Fishfinder.....1649.99

TRANSDUCERS (9 PIN BLACK)

- 26-601JHDI 9 pin Transducer.....199.99
- 26-611JP66 9-Pin Transducer279.99
- 26-618J....Active Imaging 3 in 1 Trans. (9 pin) ..519.99
- 26-610JP319 Plastic Thru-Hull.....299.99
- 26-612JB45 Bronze Thru-Hull399.99
- 26-613JSS60 S.S. Thru-Hull - 0 Deg.....699.99

- 26-616JSS60 9-Pin Thru-Hull - 12 Deg.699.99
- 26-615JB258 (1kW) Bronze Thru-Hull1429.99
- 26-609JP79 Plastic In-Hull219.99

Adaptor cable connects 9 pin transducer to 7 pin Sounder

26-608J62.99

FURUNO



600W

10 Pin



FCV 628 Sounder without transducer

26-394JFCV 628..... 1195.99

FCV628 - SOUNDER

Dual-frequency (50 kHz and 200 kHz) fish finder equipped with revolutionary new RezBoost signal processing technology. Furuno's FCV-628, 600W fishfinder offers a **5.7" high resolution color display.**

Furuno's RezBoost Sonar Technology offers unparalleled clarity and target separation that the most well know of competitors can't compete with. RezBoost is a revolutionary new signal processing technology that Furuno invented which achieves CHIRP-like performance from your traditional 600w or 1kW Transducers. The FCV628 offers up to 8 times the target separation than its predecessor the FCV627.

Furuno's FCV628 600w sounder utilizes their FDF (Furuno Digital Filter) technology, and auto adjustments technology, which help adjust gain, clutter, and output power. This makes the picture clearer and easier to decipher between baitfish and larger target species.

The 628 offers a **high resolution display** which shows underwater conditions in 8, 16, or 64 colors for a brilliant picture. The FCV628 is waterproof which allows it to be installed on any bridge or center console. Audio and visual alarms alert you whenever preset limits are met for water depth, water temperature and fish echoes. The FCV-628 is a high end stand alone fishfinder providing exceptional underwater images at an affordable price point.

Transducer NOT Included. Depth penetration to 2500 feet. Unit reads in feet, fathoms, or meters.

FURUNO



600W or 1 KW

10 Pin



FCV588 Sounder without transducer

26-398JFCV588 2395.99

FCV588 - SOUNDER

Outstanding Clarity and Exceptional Target Separation Viewed on an **8.4" Display.** Furuno offers both fresh and saltwater anglers the perfect stand-alone fishfinder with a large, bright screen that's intuitive to operate. Compact, durable and housed in a waterproof case with a perfect sun-light viewable VGA polarized screen, the Furuno FCV-588 is a must have and is sure to be on many boaters wish lists for years to come.

Furuno's RezBoost Sonar Technology offers unparalleled clarity and target separation. RezBoost is a revolutionary new signal processing technology that Furuno invented which achieves CHIRP-like performance from your traditional 600w or 1kW Transducers. The FCV588 offers up to 8 times the target separation than its predecessor the FCV587.

The 588 utilizes Furuno's FDF (Furuno Digital Filter) technology to identify the transducers wattage capacity and adjust its output power to match. The digital filter helps adjust much more than just gain, STC and output power; it also helps reduce an inaccurate depth presentation when a large bait pod is right below the transducer obstructing the pulse.

Post Processing Gain Control allows you to adjust the gain not only on the returns from that point forward, but also for the existing returns that are still on the display. This is a quick and easy way to assist in determining what settings are best for the current water conditions. Every boater knows that your fishfinder functions a little differently according to the water's clarity and that will vary based on recent storms, local currents and the composition of the sea floor.

Transducer NOT Included. Depth penetration to 2500 feet. Unit reads in feet, fathoms, or meters.

TRANSDUCERS FOR ABOVE FURONO FCV628 & FCV588

- Furuno Plastic T-Hull Transducer (P319)
- 26-220J 50/200 khz.....189.99
- Furuno Plastic Stern Mount Transducer (P66)
- 26-221J 50/200 khz179.99
- Furuno Bronze T-Hull Transducer (B117)
- 26-222J 50/200 khz.....369.99
- Furuno Bronze T-Hull Transducer (B45)
- 26-280J 50/200 khz.....399.99

- Furuno Bronze T-Hull Transducer (B744V)
- 26-224J 50/200 khz..... 789.99
- Furuno Bronze T-Hull Transducer (B258)
- 26-226J 1 kW 1579.99
- Transducer 12' Extension Cable - 10 pin
- 26-227J 159.99

Adaptor Cables

- 8 pin Trans. to 10 pin Sounder
- 26-228J 139.99
- 10 pin Trans. to 8 pin Sounder
- 26-229J 139.99

GP39 MARINE WAAS / GPS NAVIGATORS

Compact GPS Navigator with 4.2" LCD Display

The Furuno GP39 offers a bright high resolution 4.2 inch display with a newly designed GPS core offering better accuracy with its integrated SBAS (WASS/EGNOS/MSAS) Technology. The unit has 7 available display modes, which includes 2 customizable modes. No need to worry about losing your waypoints and routes again. The GP39 offers data transfer via a USB flash drive and also a signal converter. **Comes with External Antenna.**

With an improved mounting bracket, the GP39 display can be mounted or un-mounted quickly and easily and can even be interfaced with a fish finder, sonar, radar or other navigation equipment for sending accurate navigation data. Receiving the TLL (Target Latitude/Longitude) sentence from interfaced fish finders or sonars the GP39 can display the received information, allowing you to easily mark fish school locations.

Internal memory allows 3,000 track points, 10,000 waypoints and 100 routes. The Furuno GP39 allows you to display data in Loran TD's which is a key feature that many other GPS units do not offer. Built with a waterproof housing to IP55 standards, the GP39 can be used as a standalone GPS or even a reliable back up.

GP39 Marine WAAS/GPS Navigator

26-267J849.99



↗ 4.2"

GPS/Radars

16 MILE RADAR - MODEL 1623

The Model 1623 LCD micro-radar offers Furuno performance at an economical price! Features include: Microstrip antenna housed in a compact 15" radome weighing a mere 9.9 lbs.. Automatically changes antenna rotation speed depending on the range scale selected (25, 31 and 41 RPMs) 13 range scales from 0.125 to 16 nautical miles. 5.7" LCD display with 4 gray tones and 240 x 320 pixels. Antenna cable measures 10 Meters, (33 feet). 7.3"W x 7.7"H x 3.3"D.

- 16 Nautical Mile Range
- 5.7" Mono LCD Display
- 15" Radome Antenna
- 2.2 kWPower Output

26-178H (10.2 - 31.2 VDC) 2499.99



↗ 5.7"

FURUNO 1815 - 36 MILE COLOURED LCD RADAR

MODEL1815 is an 8.4" color LCD radar designed for pleasure craft and small fishing boats. The Radar has easy-to-use, intuitive controls, while maintaining the high performance you expect from FURUNO products. Even in poor visibility such as fog or storms, the radar produces detailed pictures of coastline and targets at short ranges by utilizing narrow pulses and dual IF bandwidths. The waterproof display makes it ideal for exposed installations, such as fly bridges. MODEL1815 utilizes our Fast Target Tracking™, True Trail Mode and True View Mode technologies to ensure optimum performance in detecting and ranging targets of interest. Low power consumption of 38 W at the most. Swivel mounting bracket to adjust the angle of the display unit

- 36 Nautical Mile Range
- 8.4" LCD Colour Display
- 19" Radome Antenna
- 4 kWPower Output
- 5.2 degrees Horizontal Beamwidth

26-399H..... Radar 18154299.99



↗ 8.4"

GPS ELECTRONICS



Now available for compatible Lowrance, Garmin, & Furuno Sounders.



P319 Plastic T-Hull Transducer

The P319 features our 50/200 kHz, dual-frequency, single-ceramic element in a low-profile housing. The nearly-flush design minimizes drag with only 5 mm (3/16") extending outside of the hull.

Features:

- * Depth / Temp (optional)
- * 50/200 kHz
- * 600 W RMS
- * Mid-performance
- * Plastic



B117 Bronze T-Hull Transducer

The B117 features our 50/200 kHz, dual-frequency, single ceramic element in a low-profile housing. The nearly-flush design minimizes drag with only 5 mm (3/16") extending outside of the hull.

Features:

- * Depth / Temp (optional)
- * 50/200 kHz
- * 600 W RMS
- * Mid-performance
- * Bronze



SS60 Stainless Steel T-Hull Transducer

The SS60 is the stainless-steel version of our popular, B60, Tilted Element™ transducer.

Features:

- Engineered for center-console and trailered boats
- Low-profile protrusion below the hull
- No affect on your boats running performance
- Arrow on cap points toward keel when installed
- Built-in temperature sensor
- Boat Size: Up to 8 m (25')
- 0°, 12°, or 20° Tilt
- Stainless steel transducer housing



B45 Bronze T-Hull Transducer

The B45 is our smallest and most economical, dual-frequency, bronze, stem transducer.

Features:

- Recommended for planing-hull powerboats and cruising sailboats up to 9 m (30')
- Good sensitivity in a compact housing
- Fast-response water-temperature sensor
- 50/200 kHz
- 600 W RMS
- Mid-performance
- Bronze transducer housing



B744V Bronze T-Hull Transducer

These TRIDUCER® multisensors feature depth, speed, and temperature in a single housing—drill only one hole in the boat! The 50/200 kHz, dual-frequency, single ceramic element provides good target detail in shallow water at 200 kHz and good deep-water bottom tracking at 50 kHz. The B744VL's extended stem-length has the extra height needed for steep-deadrise vessels or thick, cored hulls.

Features

- * Depth / Speed / Temp
- * 50/200 kHz
- * 600 W RMS
- * Mid-performance
- * Bronze



B258 Bronze T-Hull Transducer

Sport fishermen get excellent 1 kW performance with the moderately-priced B258. Its economical, four-ceramic-element construction puts out a narrow beam for good deep-water capability with very good target and bottom definition. For the best possible results, Airmar recommends coupling it with a High-Performance Fairing.

Features

- * Depth / Temperature
- * 50/200 kHz
- * 1 kW RMS
- * High Performance
- * Bronze



WOODEN OARS

Quality varnished oars. Spruce. Sold per pair.

46-1035M	6 ft.	99.95 /pr.	46-1038M	9 ft.	156.95 /pr.
46-1036M	7 ft.	106.95 /pr.	46-1039M	10 ft.	189.95 /pr.
46-1037M	8 ft.	124.95 /pr.			



ASPEN PADDLES

Quality varnished paddles. Spruce. Priced per paddle.

46-1044R.....	48"	35.95 /ea.
46-1045R.....	54"	35.95 /ea.
46-1046R.....	60"	35.95 /ea.
46-1047R.....	63"	35.95 /ea.

PLASTIC OARS

45" in length.

46-1030R.....	17.95 ea.
---------------	-----------

FOX 40 TELESCOPIC PADDLES

Telescoping paddle is lightweight with aluminum shaft. Adjusts to varying lengths with a quick twist of the handle. Simple locking device ensures that extended handle remains in place while paddling. Includes sturdy boat hook for retrieving items. Measures 21" in closed position, 42" at full extended length.

50-240R.....	24.95 ea.
--------------	-----------





PERKO



NL's
Most
Popular



Top Mount



Side Mount



Top Mount

Side Mount

OARLOCK HORNS

Zinc - 1 3/4" opening.

46-345R..... 15.90 pr.

Chrome plate - 1 3/4" opening.

46-346R..... 30.45 pr.

OARLOCK SOCKETS

Top Mount

46-348R..... Zinc20.95 pr.

46-350R Chrome29.25 pr.

Side Mount

46-349R..... Zinc24.35 pr.

46-351R Chrome39.05 pr.

OARLOCK HORNS

5/8" Taper Shank Type – Galvanized

Commercial Duty - 2 1/4" opening x 5/8" tapered shank.

46-292R 11.95 ea.



GALVANIZED FOLDING OARLOCK HORN

Prevents loss of oarlocks. Horn stays in socket inside your boat when not in use. When needed, oarlock slides up into socket and locks in place.

46-976R.....A= 2 1/8" - B= 8"9.95 ea

46-978R.....A= 2 3/4" - B= 9 1/2"14.95 ea

OARLOCK SOCKETS

Top Mount Galvanized

46-295R.....5/8" Tapered Shank5.50 ea.

Side Mount Galvanized

46-298R.....5/8" Tapered Shank 5.50 ea.

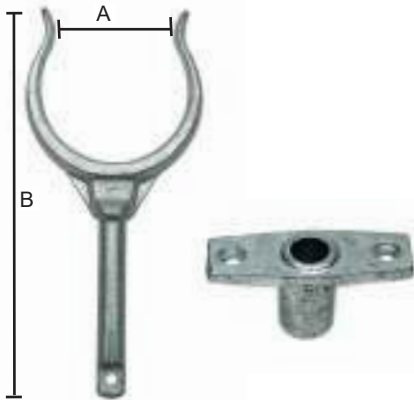

BLACK NYLON ROW LOCKS

46-989R2"2.95 ea.

46-991R.....Top Mount Socket.....2.25 ea.

OARLOCK HORNS & TOP MOUNT SOCKET

1/2" Straight shaft – Galvanized

A = 2 1/8" B = 7 3/4"

46-981R.....Oarlock Horns.....9.95 ea

1/2" Straight shaft – Galvanized

46-986RSocket3.25 ea

Don't Forget To Check Our Website For Up To Date Pricing.

www.mercersmarine.com



MARINE JACKS

1000 LBS, single wheel

Fast, easy swivel jack operation. Factory assembled mounting bracket provides easy trailer installation. Provides up to 25" of lift. Heavy duty 3" plated steel tubing, 6" poly wheel. Fits trailer tongues from 3" to 5".

46-383P1000lb69.95



1500 LBS, dual wheel

Heavy duty swivel mechanism makes for easy operation with superior load capabilities. 1500lb. capacity heavy duty jack features 2 - 6" wide profile wheels for maximum ground support. Ideal for use on soft surfaces. Extra lift for vehicles with high platforms up to 27". Fast, easy jack operation fits trailer tongues from 3" to 5".

46-386P1500lb209.95



WINCH STRAP

Nylon webbing winch strap 2"W x 20' long. Complete with hook.

46-395P16.95



FULTON TRAILER WINCHES

All FULTON winches include the following features: comfort grip handle for positive hold while cranking; zinc plated finish for superior corrosion resistance, even in salt water environments; winch drums are drilled for use with winch straps; high carbon steel gears to resist wear and last longer; heavy duty ribbed frames maintain proper gear alignment for longer life; internally lubricated bushings so cranking is kept easy. Made in USA.

Model 142100

1100lb capacity - 4:1 Gear Ratio - "Grabber" one way ratchet.

46-387P1100lb model74.95



Model 142300

1800lb capacity - 5:1 Gear Ratio - 2 way ratchet.

46-388P1800lb model119.95



Model 142411

2600lb capacity - 5:1 Gear Ratio - C/W Hand brake kit.

46-389P2600lb209.95



FULTON TRAILER WINCH (3200 LBS)

Fulton two speed trailer winches are designed to make light work of heavy loads. Featuring one fast speed for quick pull-in, and a second low speed for increased mechanical advantage, these winches also include a shift lock design which allows changing gears without moving the crank handle from shaft to shaft. Simply lift the shift lock and slide the shaft into the desired position to hold the shaft in gear.

- 2 speeds
- 3200 lbs. capacity
- Bright zinc finish
- Comes with HD strap

Model 142423

46-405P3200lb model299.95



FULTON DELUXE WINCH (3200 LBS)

Fulton two speed trailer winches are designed to make light work of heavy loads. Featuring one fast speed for quick pull-in, and a second low speed for increased mechanical advantage, these winches also include a shift lock design which allows changing gears without moving the crank handle from shaft to shaft. Simply lift the shift lock and slide the shaft into the desired position to hold the shaft in gear.

- 2 speeds
- 3200 lbs. capacity
- Black cover
- 20' strap included
- Comes with brake

Model 142425

46-406P3200lb model335.95



ROCKER ROLLER - RIBBED

- 90-140K.....4 3/8" dia. x 3" - 7/8" shaft21.95
- 90-141K5" dia. x 3" - 7/8" shaft22.95



BOW ROLLERS

Usually installed on the trailer winch stand, as a bow stop.

- 90-125K3" - 1/2" shaft.....5.99
- 90-126K4" - 1/2" shaft.....6.99



SPOOL ROLLERS

Designed for smaller, lighter boats.

- 90-130K4" - 1/2" shaft.....6.95
- 90-131K5" - 5/8" shaft.....7.95



ROCKER ROLLER - SMOOTH

Moves based on pressure exerted during loading of boat. Fits any hull's contour.

- 90-147K.....4 1/4" dia. x 4 1/4" - 7/8" shaft.....14.95



SIDE ROLLER

Helps center the boat and prevent damage from trailer fenders and lights.

- 90-137K.....12" x 2 1/2" - 5/8" shaft25.95



MOLDED Y-STOP

- 90-134K3" - 1/2" shaft11.95
- 90-135K4" - 1/2" shaft14.95



KEEL ROLLERS

Engineered to support the added weight of heavier boats by properly positioning the keel centered on the roller.

- 90-120K8" - 5/8" shaft.....14.95
- 90-121K10" - 5/8" shaft.....19.95
- 90-122K12" - 5/8" shaft.....22.95



8" YELLOW KEEL ROLLER

Smooth, non-marring, resilient protection. Impervious to sunlight, chemicals and fuels. Fits 1/2 inch diameter shafts.

- 90-208K.....32.95



YELLOW BOW ROLLER

Non-marring, resilient bow protection. Smooth finish helps boat roll easily into place. Impervious to sunlight, chemicals, and fuels.

- 90-204K.....3"8.50
- 90-205K.....4"10.95



YELLOW SPOOL ROLLER

Smooth, non-marring, resilient protection. Impervious to sunlight, chemicals and fuels. Fits 1/2" diameter shafts.

- 90-212K.....4"12.95
- 90-213K.....5"14.95



3.5" YELLOW BOW ROLLER (BELLS)

Non-marring, resilient bow protection. Smooth finish helps boat roll easily into place. Impervious to sunlight, chemicals, and fuels

- 90-206K.....32.95



MERCER'S



PANEL BRACKETS

Heavy duty, plated steel one piece design for specific sized rollers. Slots provide vertical adjustment for installation of roller shaft.

90-175K.....	For 4" roller	23.95
90-177K.....	For 5" roller.....	24.95
90-180K.....	For 8" roller.....	33.95
90-182K.....	For 10" roller.....	34.95
90-184K.....	For 12" roller.....	36.95



BOLSTER BRACKET

Slotted to easily mount 2" x 4"s for boat hull height adjustments. Available in 3 sizes.

90-195K.....	8"	9.95
90-196K.....	10"	11.95
90-197K.....	12"	12.95



GALVANIZED BUNK BRACKETS

For mounting bunks. Slotted for vertical adjustments. Mounts with 1/2" bolt. 11 gauge galvanized steel.

90-220K.....	8" X 2"	7.50
90-221K.....	10" X 2"	9.50



SPLIT ROLLER BRACKET

Heavy duty, plated steel two piece design for various sized rollers.

90-192K.....	19.95
--------------	-------	-------



PAL NUTS

Attach to end of shaft to retain roller.

90-188K.....	1/2"	1.95
90-189K.....	5/8"	3.50



ROLLER SHAFTS

90-160K.....	1/2" x 5 1/4"	11.75
90-162K.....	1/2" x 6 1/4"	11.75
90-166K.....	5/8" x 6 1/4"	12.95
90-168K.....	5/8" x 9 1/4"	15.95
90-170K.....	5/8" x 11"	17.95
90-171K.....	5/8" x 13 1/2"	18.95

PLASTIC WHEEL CHOCKS

Use when vehicle is parked. Use when changing tires. Durable and lightweight.

90-235M.....	7"L x 5"W x 4"H	8.95 ea.
--------------	-----------------------	----------



HITCH BALLS

1 7/8" x 3/4" model	
46-392P.....	13.95
2" x 3/4" model	
46-393P.....	14.95
2 5/16" x 1" model	
46-394P.....	22.95



TRAILER COUPLERS

Fast-Lock, straight tongue.

Class I = Ball size = 1 7/8" x 2 1/2" Channel. GVW 2000lbs.

46-390P.....	31.95
Class II = Ball size = 2" x 3" Channel. GVW 3500lbs.	
46-391P.....	36.95



FULTON TRAILER HITCH LOCK

Economical theft deterrent. Solid cast lock body Fits all FAS-LOK™ and other standard couplers.

46-664P.....	17.50
--------------	-------



FULTON OUTBOARD MOTOR LOCK

Keep your Outboard motor safe and secure with the FULTON Outboard Motor Lock. Heavy-duty barrel key lock mechanism for maximum security. Foam filler insert reduces noise and vibration. Mounts on most outboard motors.

46-665P.....	58.95
--------------	-------



COMBINATION UNDER 80" TAIL LIGHT KIT

Kit comes complete with two tail lights, two amber clearance/side marker lights with reflex lens, 25' trailer wiring harness cable with moulded 4-way flat prong plug, 4' car wiring harness cable with moulded 4-way flat prong plug and license plate bracket. (#2823285)

90-230P 69.95



WATERPROOF OVER 80" LOW PROFILE TAIL LIGHT KIT

Kit comes complete with two tail lights, two sealed amber surface mount clearance/side marker lights with reflex lens, 25' trailer wiring harness cable with moulded 4 prong plug, 4' four wire car wiring harness cable with moulded 4-way plug and license plate bracket. (#007509)

90-231P 99.95



LED LOW PROFILE WATERPROOF TRAILER LIGHT KIT

Kit comes complete with two low profile tail lights, 25' wiring harness cable with moulded 4-way plug, 4' four wire car wiring harness cable with moulded 4-way plug and license plate bracket. (#407540)

90-232P 169.95

FULTON



FULTON BOAT GUIDE

The Fulton GB150 boat guides/trailer positioners help you keep the boat centered and provide extra trailer visibility, saving time and possible damage, when launching and loading. Universal bolt-on mounting system fits all trailer frames up to 3" wide by 5" tall, no drilling or cutting required. Unique, non-marring, marine grade PVC uprights extend 50" up from frame, helping to prevent hull damage, and providing trailer visibility when backing up. Features side-to-side adjustment, allowing optimum fit to any trailer. Keep trailer lights high, dry and visible with the convenient mounting kit, allowing trailer lights to be fitted to boat guide uprights. Mounting instructions and all necessary hardware included.

90-217P 159.95



BUNK CARPETING

Marine grade carpeting allows the do-it-yourselfer to replace worn and dirty carpet on bunk trailers. The carpet protects your boat investment by reducing scratching on the hull and keeps it in like-new condition.

Size : 12" W x 144"L

90-118P 39.95



60° END BASES

Polished 316 stainless steel.

46-012R7/8", 60°17.95
46-013R1", 60°17.95



INTERMEDIATE BASES

Polished 316 stainless steel.

46-014R7/8", 60°13.95
46-015R1", 60°16.95
46-864R1", 90°10.95



END MOUNT RAIL BASE

Polished 316 stainless steel. Drilled and countersunk for 1/4" fasteners.

46-862R1"39.95
---------	---------	------------



110° BOW FORM

Polished 316 stainless steel. C / W screws.

46-425R7/8"29.95
---------	-----------	------------



3 WAY, 90° CORNER

Polished 316 stainless steel. C / W screws.

46-329R7/8"23.95
46-330R1"26.95



316 Stainless Steel

STAINLESS STEEL TUBING

Supplied in 20 feet lengths.

316 stainless steel

46-913P7/8"P.O.R.
46-914P1"P.O.R.



HALF OVAL MOULDINGS

STAINLESS STEEL

Hollow Back, Pre-drilled every 6".

46-572K3/4" x 12'P.O.R.
46-573K1" x 12'P.O.R.
46-574K1 1/4" x 12'P.O.R.



90° TEES

Polished 316 stainless steel. C / W screws.

46-006R7/8"19.95
46-007R1"22.95



60° TEES

Polished 316 stainless steel. C / W screws.

46-008R7/8"22.95
46-009R1"19.95



SOCKET HEAD SET SCREW

62-385T1/4" - 28 x 3/160.51
---------	-----------------------	-----------



60° RAIL BASES

Polished 316 stainless steel. C / W screws.

46-005R7/8" Round Base17.95
46-136R1" Round Base19.95
46-002R7/8" Rectangle Base23.95
46-003R1" Rectangle Base25.95



90° RAIL BASES

Polished 316 stainless steel. C / W screws.

46-004R7/8" Round Base17.95
46-137R1" Round Base18.95
46-000R7/8" Rectangle Base16.95
46-001R1" Rectangle Base18.95



45° RAIL BASES

Polished 316 stainless steel. C / W screws.

46-328R7/8" Round Base17.95
46-742R1" Round Base18.95



90° ELBOWS

Polished 316 stainless steel. C / W screws.

46-010R7/8"15.50
46-011R1"19.95



STAINLESS STEEL ROD HOLDER WITH CAP

Stainless steel flush mount rod holder. 1-7/8" x 9-1/2".

46-1107R19.95
----------	-------	------------



STAINLESS STEEL HANDRAIL

External screw base handrail. This handrail is fastened from the top. 7/8" Dia.

- 46-1305R.....approx. 8" O.D. Flange24.95
- 46-1306R.....approx. 12" O.D. Flange28.95
- 46-1307Rapprox. 19.5" O.D. Flange32.95
- 46-1308R.....approx. 24" O.D. Flange34.95



RAIL MOUNT FLAG POLE

316 stainless steel. Comes complete with heavy duty hinged rail clamp. Quick release adjustable flag clips. For 7/8" railing. 17 3/4" high. Will accept up to 12" flag.

- 46-016R.....38.95



FLAGS

- 40-018PCanada Flag - 9" x 18"13.95
- 40-019PCanada Flag - 12" x 24"16.50
- 40-023PNL Flag - 9" x 18"19.95
- 40-024PNL Flag - 12" x 24"23.95

More flags available on page 568



HANDLE

Chrome plated brass construction. 4 3/4" L x 1 3/4" H. 3" inside. Countersunk for #8 screws.

- 46-049R.....13.95



PERKO BOW HANDLE

Chrome plated zinc. 6 1/2" O.L. x 2" above deck. Countersunk for #8 screws.

- 46-042R.....24.85



DURABLE TYPE FASTENERS

For canvas to surface use Figures 869, 896, and 898. For canvas to canvas use figures 896, 898, 901 and 907.

- 46-025R.....Stud/Screw (869).....1.53 ea
- 46-026R.....Eyelet (907).....0.34 ea
- 46-027R.....Stud (901).....0.35 ea
- 46-028R.....Button (896).....0.60 ea
- 46-029R.....Socket (898).....0.56 ea



CURTAIN FASTENERS



Nickel plated brass.

- 46-030R.....Eyelet.....1.10 ea.
- 46-031R.....Stud.....4.69 ea.
- 46-032RWasher.....0.60 ea.



316 STAINLESS TOP SLIDE WITH CLEVIS

- 46-145R.....7/8".....21.95
- 46-146R.....1".....21.95



316 STAINLESS SIDE MOUNT HINGE

- 46-023R.....9.95



PERKO HANDLE

Chrome plated zinc.

6" L x 1 5/16" H. 3 1/2" inside opening. Countersunk for 1/4" fasteners.

- 46-048R.....17.45



316 STAINLESS CANVAS TOP FITTINGS

Polished 316 stainless steel.

TOP CAP

- 46-021R.....3/4"11.95
- 46-022R.....7/8"9.95
- 46-102R.....1"15.95



316 STAINLESS TOP CAP

316 Stainless steel swiveling deck hinge /top cap

- 46-954R.....7/8"28.95
- 46-955R.....1"29.95



316 STAINLESS TOP SLIDE

- 46-019R.....3/4"10.95
- 46-020R.....7/8"10.50
- 46-101R.....1"13.95



90 DEGREE HINGES

316 Stainless steel hinge with removable pin.

- 46-951RConcave Mount.....14.95
- 46-024RFlush Deck Mount.....14.95



REMOVABLE SPRING PIN

316 Stainless Steel spring loaded pin for use with Canvas top fittings.

- 46-999P3.50



DELUXE STAINLESS STEEL EYE BOLTS

316 stainless steel. Shouldered.

46-752R.....	6mm(1/4") x 2 3/8"L.....	10.50
46-753R.....	8mm(5/16") x 3 1/8"L.....	12.95
46-754R.....	10mm(3/8") x 4"L.....	20.95
46-755R.....	12mm(1/2") x 4 3/4"L.....	33.95



STAINLESS STEEL EYE BOLTS

316 stainless steel.

46-193R.....	6mm(1/4") x 2"L.....	2.75
46-194R.....	8mm(5/16") x 2 1/2"L.....	3.50
46-195R.....	10mm(3/8") x 2 3/4"L.....	5.95
46-196R.....	12mm(1/2") x 3"L.....	8.95



GALVANIZED SHOULDERED EYE BOLTS

46-171R.....	1/4" x 2"L.....	2.75
46-172R.....	5/16" x 2 1/4"L.....	3.10
46-173R.....	5/16" x 4 1/4"L.....	3.95
46-174R.....	3/8" x 2 1/2"L.....	3.85
46-175R.....	3/8" x 4 1/2"L.....	4.25
46-178R.....	1/2" x 6"L.....	6.95
46-181R.....	1/2" x 10"L.....	8.95
46-179R.....	5/8" x 6"L.....	9.95
46-182R.....	5/8" x 10"L.....	14.50
46-180R.....	3/4" x 6"L.....	13.50
46-496R.....	3/4" x 8"L.....	15.95
46-497R.....	3/4" x 10"L.....	19.95
46-498R.....	3/4" x 12"L.....	20.95
46-183R.....	1" x 9"L.....	37.95



GALVANIZED SCREW EYES

Shouldered.

46-164R.....	1/4" x 2"L.....	3.50
46-165R.....	5/16" x 2 1/4"L.....	4.45
46-166R.....	3/8" x 2 1/2"L.....	4.75
46-167R.....	1/2" x 3 1/4"L.....	7.50
46-168R.....	5/8" x 4"L.....	10.95



STAINLESS STEEL SCREW EYE BOLT

46-972R.....	1/4" x 2 3/8"L.....	4.50
46-973R.....	5/16" x 2 1/2"L.....	4.95
46-974R.....	3/8" x 3"L.....	8.50
46-975R.....	1/2" x 4"L.....	14.95



STAINLESS STEEL BOW EYES

Complete with nuts and washers.

46-199R.....	3/8" x 5".....	13.95
46-200R.....	1/2" x 5-1/4".....	24.95



DELUXE STAINLESS BOW EYES

304 high polish stainless. Re-designed with welded face plate to reduce potential rust problems and provide superior sealing. Heavy quality, very attractive.

46-685R.....	3/8" x 5".....	22.95
46-686R.....	1/2" x 6 1/4".....	34.95



STAINLESS STEEL U-BOLT

#316 stainless steel.

46-1318R.....	1/4" x 3 1/2".....	3.95
46-1319R.....	5/16" x 4".....	5.95
46-1320R.....	3/8" x 5".....	10.95
46-1321R.....	1/2" x 6".....	17.95



RING BOLTS

304 stainless steel.

46-189R.....	6mm(1/4") x 2 1/4"L.....	4.50
46-190R.....	8mm(5/16") x 3 1/4"L.....	6.95
46-191R.....	10mm(3/8") x 3 3/4"L.....	12.95
46-192R.....	12mm(1/2") x 4 3/4"L.....	14.95



WORK LOAD RATED RING BOLTS

304 stainless steel "forged". Work load limit is 5:1.

46-907R.....	3/8" x 6"L (1000 lb. WLL).....	27.95
46-908R.....	1/2" x 6"L (1400 lb. WLL).....	44.50
46-909R.....	1/2" x 8"L (1400 lb. WLL).....	48.50
46-910R.....	3/4" x 10"L (3250 lb. WLL).....	179.95



TURNBUCKLES

316 STAINLESS STEEL – EYE & EYE
L=minimum overall length.

46-201R.....	1/4" x 6 1/2"L.....	5.50
46-202R.....	5/16" x 8 1/4"L.....	9.95
46-203R.....	3/8" x 9 1/2"L.....	15.95
46-204R.....	1/2" x 13"L.....	28.95



STAINLESS STEEL – JAW & JAW

L=minimum overall length.

46-600R.....	1/4" x 6"L.....	8.95
46-601R.....	5/16" x 7"L.....	13.95
46-602R.....	3/8" x 7 1/2"L.....	19.95
46-603R.....	1/2" x 8 3/8"L.....	36.95

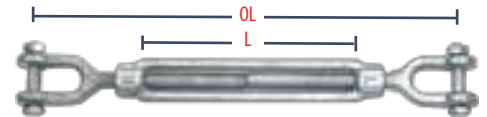

GALVANIZED – JAW & JAW (COMMERCIAL GRADE)

OL=minimum appr. overall length (Pin to Pin).

L=inside length.

46-505R.....	3/8" x 6"L x 11" OL.....	10.95
46-506R.....	1/2" x 6"L x 12" OL.....	14.95
46-507R.....	5/8" x 6"L x 14" OL.....	26.95
46-508R.....	3/4" x 12"L x 21" OL.....	46.95

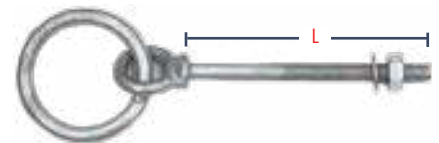

GALVANIZED RING BOLTS

46-609R.....	3/8" x 4 1/2"L.....	9.95
46-610R.....	3/8" x 6"L.....	12.50
46-611R.....	1/2" x 6"L.....	21.95
46-612R.....	1/2" x 8"L.....	29.95
46-613R.....	3/4" x 10"L.....	75.95





STAINLESS MOORING STAPLES

Install on the deck or transom. Unlike cleats, lines or gear will not catch on them. Supplied with two washers and two nuts.

3/4" diameter, 8" wide x 8 1/2" deep
46-539R..... 109.00

1" Diameter, 8 1/2" wide x 8 1/2" deep
46-540R..... 159.00



HAWSE PLATES

316 Polished stainless steel

Flange – 6 1/2" x 3 3/8". Hole size is 4" x 2".

46-745R..... 49.95



STAINLESS STEEL RING ON PLATE

5/16" stainless steel ring.

Plate size is 2" x 2 3/8".

46-205R..... 6.95



ROPE DECK PLATE

316 stainless steel. O.D. 5 1/2" x 4" I.D. 4 1/8" x 2 3/4"

46-1015R..... 79.95



ROPE DECK PLATE

Chrome plated. O.D. – 3 3/8". Hinged cover.

Countersunk for #8 screw.

46-653R..... 53.50



GALVANIZED CLEATS

46-093R.....4"	1.95
46-094R.....5"	3.75
46-095R.....6"	4.25
46-096R.....8"	13.95
46-097R.....10"	18.95
46-098R.....12"	29.95
46-099R.....14"	47.95
46-100R.....18"	129.95



HEAVY DUTY WHARF CLEAT

Heavy duty cleat with rust resistant primer. 24" overall length x 7"H. Base 12 3/4"L x 4 1/2"W.

Pre drilled for 1 1/8" bolts. Weight is 87lbs.

46-487K..... 365.00



BOLLARD

Stainless steel.

Base: 3 3/16" O.D. x 4 3/4"W x 6"H x 6"L

46-485R..... 149.95



PERKO OVAL HAWSE PIPE

Chrome plated brass. Outside Dimensions = 4 1/4" x 6"
Inside Dimensions = 2 1/8" x 4 1/8"

Spigot Length = 1 1/4"

46-458R..... 230.95



OPEN BASE CLEATS

Chromed Zinc. Exceptionally high quality cleat.

46-353R..... 4"	23.85
46-354R..... 6"	33.10
46-355R..... 8"	72.95



OPEN BASE CLEATS

316 Polished Stainless Steel

46-105R.....4"	9.95
46-106R.....6"	15.95
46-107R.....8"	26.95
46-108R.....10"	42.95
46-109R.....12"	59.95



BOW CHOCKS

Polished Stainless steel

46-125R..... 4 1/2"	44.95 pair
46-126R.....6"	49.95 pair



SKENE BOW CHOCKS

Polished Stainless steel. For light duty applications.

46-117R.....4 1/2"	29.95 pair
46-118R.....6"	44.95 pair



STRAIGHT CHOCKS

Stainless steel

46-122R.....5"	20.95 ea
46-123R.....6"	25.95 ea



DANFORTH STYLE ANCHORS

Galvanized. (Welded type). 70 lb to 1000lb anchors available by special order. Please inquire.

46-1242R.....	6.6 lbs.....	26.95
46-1243R.....	11 lbs.....	43.95
46-1244R.....	13.2 lbs.....	54.95
46-1245R.....	17.6 lbs.....	74.95
46-1246R.....	22 lbs.....	94.95
46-1247R.....	26.4 lbs.....	109.95
46-1248R.....	33 lbs.....	139.95
46-1249R.....	44 lbs.....	189.95
46-1250R.....	55 lbs.....	229.95



GALVANIZED FOLDING ANCHORS

These anchors solve the problem of finding enough storage room. Anchor flutes fold up when not in use and locking ring holds flutes in place. Lift and twist the ring to allow flutes to spread open and lock. Good holding power.

46-369R.....	1.5 lbs.....	12.50
46-370R.....	3.3 lbs.....	22.95
46-371R.....	5.5 lbs.....	35.95
46-372R.....	7 lbs.....	44.95
46-373R.....	8.8 lbs.....	56.95
46-374R.....	13.2 lbs.....	84.95
46-375R.....	17.6 lbs.....	112.95
46-376R.....	22 lbs.....	139.95
46-377R.....	26.4 lbs.....	164.95
46-378R.....	33 lbs.....	184.95



STAINLESS STEEL PLOW ANCHORS

316 stainless steel

46-1905A.....	48.4 lbs.....	599.00
---------------	---------------	--------

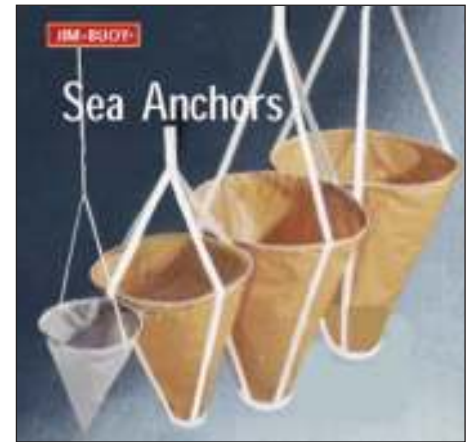

SEA ANCHORS

Vinyl coated nylon trolling sea anchor with 1" polypropylene shroud lines. Easily collapsed for storage.

50-141P.....	18" Dia (#926).....	195.00
50-142P.....	24" Dia (#927).....	225.00
50-197P.....	30" Dia (#928).....	335.00

Storm Sea Anchor

Manufactured from vinyl covered heavy nylon. Unmatched strength and durability - will not rot or mildew. Stainless steel or galvanized fittings, nylon webbing. Finest available

50-198M.....	36" Dia (#929).....	1095.00
--------------	---------------------	---------



PLOW ANCHORS

Economy plow anchor. Hot dipped galvanized steel.

46-964R.....	20lbs.....	109.95
46-965R.....	26lbs.....	139.95
46-966R.....	33lbs.....	189.95
46-967R.....	48lbs.....	269.95
46-968R.....	59lbs.....	299.95



NAVY STYLE ANCHORS

Galvanized, stockless.

46-835A.....	75lbs.....	P.O.R.
46-836A.....	100 lbs.....	P.O.R.
46-837A.....	150 lbs.....	P.O.R.
46-838A.....	200 lbs.....	P.O.R.
46-839A.....	250 lbs.....	P.O.R.
46-840A.....	300 lbs.....	P.O.R.
46-841A.....	500 lbs.....	P.O.R.



MAX-S DOCK ANCHOR

Designed by a local dockbuilder. Allows anchor to be lowered with claws in correct position. Painted steel. 135 lb. Total Length : 44 1/2". 30" Wide. 19" High.

46-1299P.....	349.00
---------------	--------



46-947
46-948



46-949

STAINLESS STEEL ROLLERS

Good quality stainless steel frame with plastic roller.

46-947R.....	2 1/2"roller x 6" H.....	74.95
46-948R.....	3"roller x 6" H.....	99.95
46-949R.....	2"roller x 8 3/4" x 2 5/8".....	64.95



ANCHOR ROLLER

Stainless steel with plastic roller, 6.5" x 2.75" x 2.87"

46-945R.....	34.95
--------------	-------



CHAIN

Galvanized mid-link chain. Priced per ft. Also, special pricing on 500 ft drums. Please inquire.

46-472R.....	3/16"	P.O.R.
46-473R.....	1/4"	P.O.R.
46-474R.....	5/16"	P.O.R.
46-475R.....	3/8"	P.O.R.
46-476R.....	1/2"	P.O.R.
46-477R.....	5/8"	P.O.R.

GRADE 80 "MID LINK"

Often used on stabilizers. NOTE: Not Galvanized

46-1090M.....	3/8"-6,600lbs W.L.L.	P.O.R.
46-1091M.....	1/2"-11,300lbs W.L.L.	P.O.R.



STAINLESS STEEL CHAIN (ASTM 80)

46-969R.....	1/4"	P.O.R.
46-970R.....	5/16"	P.O.R.
46-971R.....	3/8"	P.O.R.



BRONZE SCUPPER

Heavy duty scupper, threaded for pipe.

38-920M.....	2" Scupper	129.95
38-922M.....	3" Scupper	229.95
38-924M.....	4" Scupper	234.95

Replacement Covers

38-921M.....	2" Cover	59.33
38-923M.....	3" Cover	96.86
38-925M.....	4" Cover	109.95



GARELICK BOAT HOOKS

Telescopic

Deluxe telescopic boat hook of anodized aluminum tubing 1" x 1 1/4". Vinyl tipped cast aluminum head. Easy twist lock features non-slip handle grip.

46-306R.....	extends from 3 1/2 ft - 8ft.	72.95
46-307R.....	extends from 4.8 ft - 12ft.	89.95

Fixed

Same construction as adjustable hooks but with polycarbonate head and non-slip handles.

46-482R.....	6'	56.95
46-483R.....	8'	74.50

Plastic Replacement Head

46-305R.....		27.50
--------------	--	-------

STAINLESS BOAT HOOK HOLDERS

46-309R.....	3 1/2" x 1"	8.95/pr.
--------------	-------------	----------



TELESCOPIC BOAT HOOK

Material: Aluminum tube w/Plastic tip and locking ring.

24-206R.....	6.6'	29.95
24-207R.....	10'	34.95



CHAIN STOPPER WITH PEDESTAL

This product completes your anchor system by taking the tension of the anchor windless. Includes convenient foot tab for safe and easy lifting of stop. The pedestal elevates the chain stopper 1" off the deck. Backing plate included. Base measure 2 5/8" x 3 1/8".

46-1009R.....		119.95
---------------	--	--------



STAINLESS PAD EYE & PAD EYE W/PLATE

Pad Eye

46-594R.....	2 3/8" W	1.60
46-595R.....	2 1/2" W	2.15

Pad Eye with Plate (4 Hole)

46-782R.....	1 3/16" W x 1 3/8" L	3.69
46-783R.....	1 5/8" W x 1 3/8" L	3.95
46-784R.....	2" W x 1 1/2" L	4.59

Pad Eye with Plate (2 Hole)

46-465R.....	5/8" W x 2" L	1.35
46-466R.....	3/4" W x 2 1/4" L	1.75
46-467R.....	1" W x 3" L	2.95

MERCER'S
QUALITY & SERVICE MADE AHEAD

Go to our website at
www.mercersmarine.com
for

- Up to date Pricing
- New Products
- Stock Status
- Additional product info
- And more

210 Marine Dr. Clarenville
709-466-7430



DRAIN PLUGS

Adjustable insert.

Brass

46-184R 1" 5.50

46-359R 1 1/4" 5.75

Stainless Steel

46-138R 1" 5.95

Twist top drain plug

46-186R 1" 4.95



DRAIN SLEEVES

Fits all plugs above.

Brass

46-185R 1" x 2 7/8" 5.75

46-360R 1 1/4" x 3" 6.50

Stainless Steel

46-139R 1" x 2 7/8" 5.95



GARBOARD DRAIN PLUGS

1" square socket (Perko)

Cast bronze flange complete with square socket brass plug. Supplied with wrench.

46-170R 1" 102.00

1/2" Square Head (Perko)

46-169R 1/2" 54.45

1/2" Square Head (Imported)

46-1324R 1/2" 11.95



BAITWELL STYLE DRAIN PLUGS

Snap handle. Adjustable.

46-140R 3/8" 2.75

46-141R 1/2" 2.75

46-142R 5/8" 2.75

46-143R 3/4" 2.75

46-144R 7/8" 2.75



NYLON DRAIN PLUG

Used on inflatable and other boats. Requires approximate 1" hole.

46-299R 1" 4.50

PERKO



GARBOARD THRU-HULL DRAIN PLUG

3/4" pipe x 1 1/4" thread. Maximum hull thickness of 3/4". O.D. flange is 2 3/4".

46-912R 180.80

NEW



STAINLESS STEEL GARBOARD PLUG

2" flange x 1/2" thread. Stainless steel.

46-1323R 19.95





QUICK LINKS

316 STAINLESS STEEL

46-218R.....	1/4"	2.85
46-219R.....	5/16"	4.95
46-220R.....	3/8"	7.50
46-221R.....	1/2"	13.50

ELECTRO PLATED STEEL

Not recommended for marine use.

46-645R.....	3/16"	0.57
46-646R.....	1/4"	1.09
46-647R.....	5/16"	1.59
46-648R.....	3/8"	2.30
46-650R.....	1/2"	3.50



WIRE ROPE CLIPS

STAINLESS STEEL

46-223R.....	3/16"	1.75
46-224R.....	1/4"	3.50
46-225R.....	5/16"	4.50
46-226R.....	3/8"	9.95
46-227R.....	1/2"	10.95
46-228R.....	5/8"	13.95

GALVANIZED

46-258R.....	1/8"	0.25
46-259R.....	3/16"	0.39
46-260R.....	1/4"	0.56
46-261R.....	5/16"	0.64
46-262R.....	3/8"	0.95
46-263R.....	1/2"	1.60
46-264R.....	5/8"	2.25
46-265R.....	3/4"	3.75
46-266R.....	1"	5.75



H-G HAMMER LOCKS

46-668R.....	1/4"	5.75
46-670R.....	3/8"	11.50
46-671R.....	1/2"	16.50
46-672R.....	5/8"	24.95

YOKE HAMMER LOCKS

46-1100M.....	9/32"	10.50
46-1102M.....	3/8"	12.50
46-1104M.....	1/2"	20.95
46-1105M.....	5/8"	32.95
46-1106M.....	3/4"	59.95



316 STAINLESS STEEL SHACKLES

Polished stainless. Screw pin type.

46-238R.....	3/16"	1.65
46-212R.....	1/4"	2.95
46-213R.....	5/16"	3.95
46-214R.....	3/8"	6.50
46-215R.....	1/2"	12.95
46-216R.....	5/8"	20.70
46-217R.....	3/4"	36.95



STAINLESS STEEL "LOAD RATED" SHACKLES

316 stainless steel. Working load limit is 4:1.

Screw pin type.

46-899K.....	1/4" (1/2 ton.)	5.50
46-900K.....	5/16" (3/4 ton.)	8.50
46-901K.....	3/8" (1 ton.)	13.50
46-902K.....	1/2" (2 ton.)	26.95
46-903K.....	5/8" (3 1/4 ton.)	52.95
46-904K.....	3/4" (4 3/4 ton.)	86.95



STAINLESS STEEL THIMBLES

REGULAR

46-229R.....	1/4"	0.99
46-230R.....	5/16"	1.49
46-231R.....	3/8"	1.99
46-232R.....	1/2"	2.95

HEAVY DUTY STAINLESS STEEL

46-1062R.....	1/4"	1.75
46-1063R.....	5/16"	2.50
46-1064R.....	3/8"	4.95
46-1066R.....	1/2"	10.75
46-1067R.....	5/8"	13.95
46-1068R.....	3/4"	29.95



STAINLESS STEEL RINGS

304 stainless steel.

46-206R.....	1/4" x 2" Dia.	1.95
46-421R.....	5/16" x 2" Dia.	3.45
46-422R.....	1/2" x 3" Dia.	14.95



LOAD RATED GALV. SHACKLES

Screw pin type. Work load ratings shown below.

46-787R.....	3/16" (750 lbs)	1.89
46-788R.....	1/4" (1000 lbs)	2.19
46-789R.....	5/16" (1500 lbs)	2.59
46-790R.....	3/8" (2000 lbs)	3.45
46-792R.....	1/2" (4000 lbs)	8.45
46-793R.....	5/8" (6500 lbs)	10.95
46-794R.....	3/4" (9500 lbs)	17.50
46-795R.....	7/8" (13000 lbs)	25.95
46-796R.....	1" (17000 lbs)	35.95
46-797R.....	1 1/8" (19000 lbs)	49.95
46-798R.....	1 1/4" (24000 lbs)	64.95
46-799R.....	1 3/8" (27000 lbs)	89.95
46-800R.....	1 1/2" (34000 lbs)	115.95
46-801R.....	1 3/4" (50000 lbs)	219.95
46-802R.....	2" (70000 lbs)	299.95



GALVANIZED SHACKLES

Screw pin type.

46-241R.....	3/16"	0.69
46-242R.....	1/4"	0.89
46-243R.....	5/16"	1.19
46-244R.....	3/8"	1.95
46-245R.....	1/2"	3.95
46-246R.....	5/8"	6.75
46-247R.....	3/4"	12.50
46-248R.....	7/8"	15.95
46-249R.....	1"	20.95



GALVANIZED THIMBLES

REGULAR

46-250R.....	3/16"	0.32
46-251R.....	1/4"	0.34
46-252R.....	5/16"	0.42
46-253R.....	3/8"	0.49
46-254R.....	1/2"	0.95
46-255R.....	5/8"	2.30
46-256R.....	3/4"	3.50
46-257R.....	1"	5.95

GALVANIZED HEAVY DUTY TYPE

46-547R.....	1 1/8" - 1 1/4"	16.95
46-803R.....	1 1/4" - 1 3/8"	39.95
46-804R.....	1 1/2"	59.95
46-805R.....	2"	112.95



JAW & EYE SWIVELS

316 Stainless steel

46-207R.....	1/4"	4.99
46-208R.....	5/16"	8.95
46-209R.....	3/8"	15.95
46-210R.....	1/2"	24.95
46-211R.....	5/8"	69.95

GALVANIZED

46-155R.....	3/8"	8.45
46-156R.....	1/2"	16.95
46-157R.....	5/8"	21.95
46-158R.....	3/4"	36.95



FAST EYE SNAPS

316 Stainless steel, polished.

46-234R.....	(#0) 1/2" dia. x 2 1/8"L	4.50
46-235R.....	(#1) 5/8" dia. x 2 7/8"L	5.50
46-236R.....	(#2) 3/4" dia. x 3 1/4"L	6.50
46-237R.....	(#3) 7/8" dia. x 3 7/8"L	10.50



LOCKING SNAP HOOKS

Polished 316 stainless steel. Spring snap tongue with safety threaded screw collar.

46-810R.....	1/4"	4.50
46-811R.....	5/16"	6.95
46-812R.....	3/8"	12.95
46-813R.....	1/2"	17.95



SWIVEL EYE SNAP

316 Stainless steel, polished.

46-074R.....	(#1) 5/8" dia x 3 1/4"L	6.50
46-075R.....	(#2) 3/4" dia x 3 3/4"L	7.50
46-076R.....	(#3) 7/8" dia x 4 3/4"L	10.50



SWIVEL FLAG SNAPS

316 Stainless Steel

46-599R.....	3/4" dia x 3 1/4" long	7.95
--------------	------------------------	------



EYE & EYE SWIVELS

316 Stainless steel

46-415R.....	1/4"	5.50
46-416R.....	5/16"	7.95
46-417R.....	3/8"	13.95
46-418R.....	1/2"	23.95
46-419R.....	5/8"	54.95
46-420R.....	3/4"	99.95

GALVANIZED

46-159R.....	3/8"	7.50
46-160R.....	1/2"	13.50
46-161R.....	5/8"	17.95
46-162R.....	3/4"	33.95



FAST EYE SNAPS

316 Stainless steel, polished. Comes with spring loaded latch.

46-423R.....	4"L x 3/4" I.D. Eye	8.95
46-424R.....	4 3/8"L x 1 1/8" I.D. Eye	12.95



CLEVIS HOOKS

CLEVIS SLIP HOOKS - Forged Steel

46-443R.....	1/4"	4.95
46-444R.....	5/16"	6.50
46-445R.....	3/8"	9.95

CLEVIS GRAB HOOKS - Forged Steel

46-446R.....	1/4"	3.95
46-447R.....	5/16"	5.75
46-448R.....	3/8"	7.25



SELF LOCKING EYE HOOK (GRADE 80)

WLL = 4:1

46-1018R.....	5/16" (WLL 4000 lb)	35.95
46-1019R.....	3/8" (WLL 6400 lb)	54.95
46-1020R.....	1/2" (WLL 10800 lb)	104.95
46-1021R.....	5/8" (WLL 18100 lb)	216.95



"U.S." SWIVEL HOOKS

Breaking Load = 4 x Safe Working Load.
Elec. Galvanized. Carbon Steel.

46-449R.....	3/4 Ton (SWL)	8.60
46-450R.....	1 Ton (SWL)	11.50
46-451R.....	1 1/2 Ton (SWL)	15.95
46-452R.....	2 Ton (SWL)	18.50
46-453R.....	3 Ton (SWL)	32.95
46-454R.....	5 Ton (SWL)	68.95
46-455R.....	7 1/2 Ton (SWL)	109.95



GALVANIZED GRAB HOOKS

Forged steel.

46-152R.....	7/16" (WLL 750 lbs.)	4.99
46-153R.....	9/16" (WLL 1000 lbs.)	7.50



STAINLESS STEEL PELICAN HOOK

4" long.

46-147R.....		29.95
--------------	--	-------

PERKO



PERKO RIM LOCK SET

Chrome plated construction. Box strike, locked by turn button from inside or key from outside. For doors 3/4" to 1 1/2" thick. Case size: 3 7/8" x 2".

- 46-318P.....(Reg. Bevel #918).....239.00
- 46-459P.....(Reverse Bevel #919).....239.00

PERKO



PERKO RIM LATCH SET

Chrome plated with box strike. Locked by slide button from inside. No keys. Case size: 2 1/8" x 1 3/4".

- 46-460P.....(Reg. Bevel #928).....143.30
- 46-461P.....(Reverse Bevel #1028).....145.30

PERKO



PERKO MORTISE LATCH SET

Locked by turn button from inside only. For doors 1" to 1 1/2" thick. No keys. Case size 2 1/4" x 1 3/16".

- 46-462P.....Model 960.....142.15

PERKO



PERKO MORTISE LOCK SET

Chrome plated construction. Locks by turn button from inside or key from outside. For doors from 1" to 1 1/2". Case size: 2 3/4" x 2".

- 46-317P.....Model 927.....217.65



LOCKABLE HASP

Polished stainless steel. Complete with 2 keys. Use #6 screws.

- 46-332R.....3" x 1 3/16".....13.95



HORIZONTAL DOOR HOLDER

This heavy duty stainless steel door holder will secure your door against a rubber cushion on the projectile and hold it firmly until latch is released. Base is 2" dia. and measures 2 1/2" from wall to door.

- 46-045R.....29.95



FOLDING STEP

#316 Stainless steel. Spring loaded step. Oversized step pad. Folds flat when not in use. Screw size #14.

- 46-055R.....74.95



PERKO DOOR STOP

Chromed zinc with rubber pad. 1 1/4" O.D. x 1" long.

- 46-719R.....15.25

PERKO



PERKO DOOR HOLDER

For use on larger doors and lockers. Chromed arrow base is 3/4" x 1 5/8". Stainless steel spring clip is 7/16" x 15/16".

- 46-047R.....39.70



BRASS PADLOCK

Comes with 3 keys.

- 46-2200M.....20mm(3/4").....3.95
- 46-2201M.....30mm(1 1/4").....7.95
- 46-2202M.....40mm(1 1/2").....10.50
- 46-2203M.....50mm(2").....16.25
- 46-2204M.....60mm(2 1/4").....19.95
- 46-2205M.....70mm(2 3/4").....25.95

PERKO



PERKO HEAVY-DUTY BARREL BOLTS

Cast bronze chrome plated. Countersunk for #6 screws.
 46-464R.....1 7/16" x 3 7/16"69.85
 46-411R.....1 7/16" x 4 5/16"75.70
 46-410R.....1 7/16" x 5 1/4"87.45

PERKO



PERKO SHIP BOLT

Chrome plated bronze. Supplied with brass friction spring to prevent rattle and assure non-opening. Countersunk for #6 screws.
 46-715R.....2 5/8" x 1 1/4"81.35

PERKO



PERKO BARREL BOLT

Good looking barrel bolt. Integral friction pad eliminates rattle and assures smooth operation. Chrome plated. Use #6 round head screws.
 46-409R.....3 3/8" x 1 1/4"40.65

STAINLESS STEEL BARREL BOLT

Heavy quality 316 polished stainless steel, 1/8" thick. Friction pad to prevent rattle. Countersunk for #6 screws.
 46-704R.....1 1/2" x 3 3/4"18.95
 46-705R.....1 1/2" x 4 5/16"30.95



LIGHT-DUTY BARREL BOLT

Chrome plated brass. Use #4 screws.
 46-039R.....1 3/16" x 3"11.95

PERKO



PERKO HEAVY-DUTY DOOR HOOKS

Cast bronze, chrome plated. Many commercial vessel operators request this quality of door hook. Countersunk for #6 screws.
 46-036R.....4"64.50
 46-037R.....5"72.75
 46-038R.....6"79.75

PERKO



PERKO DOOR HOOK

Chrome plated zinc. Countersunk for #6 screws.
 46-478R2 1/4"19.40
 46-479R3"19.90
 46-480R4"20.10

2-WAY SWIVEL DOOR HOOK

Good quality "stainless steel" door hook. Double swivel action allows for use in difficult places. Very popular model. Countersunk for #6 screws.
 46-324R.....4"18.95



DOUBLE SWIVEL DOOR HOOK

#316 Stainless steel. Double swivel design. Second strike is included to keep door open. Screw size #8.
 46-040R.....4"26.95



LIGHT-DUTY DOOR HOOKS

Chrome plated brass. Good value. Use #6 screws.
 46-033R.....2"6.95
 46-034R.....3"7.50
 46-035R.....4"8.50

PERKO



PERKO HEAVY DUTY CABIN DOOR HOOK

Chrome plated zinc alloy. Robust cabin door hook from Perko.
 46-716R.....2" long17.90
 46-717R.....2 1/2" long19.30
 46-718R.....3" long20.10

PERKO



PERKO HASPS

Chrome plated. Uses #6 Screws.
 Swivel Eye Model
 46-431R.....1" x 3"38.35
 Fixed Eye Model
 46-413R.....1" x 3"31.95
 46-463R.....1" x 3 3/4"32.60



SWIVEL EYE HASP

For light duty applications. Stainless steel. Use #6 screws.
 46-046R.....1" x 3"9.95



LIGHT DUTY HASPS

Chrome plated brass. Good value. Use #6 screws.
 46-043R.....1" x 3"8.95
 46-044R.....1" x 4"13.50

PERKO



PERKO CUPBOARD CATCH

Spring loaded cupboard catch.
Heavy chrome plated. 1 1/2" x 1 7/8".
Countersunk for #8 screws.
46-414R..... 52.40

PERKO



Ideal for cupboards, lockers, etc. Chrome plated. 2 1/8" x 1 1/2". Countersunk for #6 screws.
46-058R..... 39.95

PERKO

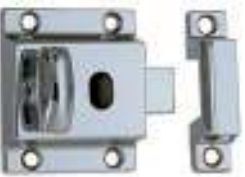

PERKO CUPBOARD TURN

Chrome plated zinc construction. Countersunk for #6 screws. Measures 2 1/8" x 2 1/4".
46-720R..... 67.00



ANTI-RATTLE DOOR KEEPER

Chrome plated brass. Stud - 1 7/16" x 1/2", catch 2 1/4" x 1/2". Countersunk for #8 screws.
46-056R..... 18.95



HATCH FASTENER

Chrome plated brass. 4" x 1 1/4". Countersunk for #6 screws.
46-429R..... 13.95



BRASS DOOR CATCH

Good quality catch. Brass body with stainless steel balls and spring. Adjustable tension.
46-525R1 3/4" x 9/32".....3.25
46-526R1 7/8" x 5/16".....3.95
46-527R2 3/8" x 3/8".....5.95



BRASS ELBOW CATCH

Polished brass catch with adjustable striker plate. Catch has stainless steel spring. Countersunk for #4 screws.
46-068R..... 3.95

PERKO



PERKO PLASTIC ELBOW CATCH

Perko Product. Black plastic with adjustable striker plate and integral spring.
1 3/16" x 5/8".
46-057R 9.40 (2/pk.)



PERKO DOOR CATCH

Made by PERKO.
1 1/8" x 3/8" stud. 1 3/8" x 7/8" catch. Use #4 round head screws.
46-432R10.70 (2/pk.)

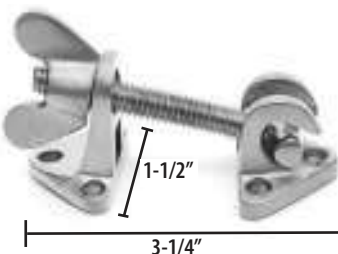

STAINLESS STEEL HATCH FASTENER

5/16" rod and wing nut.
46-188R.....24.95

NEW



AAA
AAA Hardware, Inc.

SLIDING DOOR/WINDOW STOP

Overall length 3". Stainless Steel with plastic cover.
46-769R..... 24.95

PERKO



DOOR BUTTON

Chrome plated with black plastic knob and bronze spring. Countersunk for #6 screws.
46-062R..... 20.75

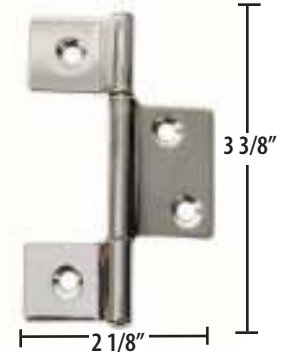

STAINLESS STEEL 2-WAY HINGE

#8 Screws
46-082R.....5.50



BRASS KEY CHAINS

Brass nautical keychains. Hi-polished. Good idea as a "Stocking Stuffer" for Christmas.
60-039PAnchor4.95
60-040PShip's Wheel.....4.95
60-041PPropeller.....4.95



FLOATING KEY CHAIN

Not necessarily in color shown.
46-511R.....4.59



HEAVY DUTY BUTT HINGES

304 stainless steel, heavy quality. Suitable for most exterior doors on commercial vessels.

- 46-722P.....3" x 3" 30.95
- 46-723P.....4" x 4" 49.95



MEDIUM DUTY STRAP HINGES

Polished 316 stainless steel. 1/8" thick. Countersunk for #10 screws.

- 46-438R4" x 1" 11.95
- 46-437R6" x 1 1/8" 15.95



LIGHT DUTY BUTT HINGES

Polished 316 stainless steel. 1/16" thick. Countersunk for #8 screws.

- 46-585R.....1 1/2" x 2"4.50
- 46-077R.....2" x 2"5.25
- 46-078R.....2" x 3"5.50
- 46-079R.....3" x 3"6.50



STAINLESS STEEL T- HINGES

Heavy duty 304 stainless steel construction.

- 46-871P.....1 1/2" x 5"39.95
- 46-872P.....2" x 8"93.95



MEDIUM DUTY HINGES

Polished 316 stainless steel. 1/8" thick. Countersunk for #8 screws.

- 46-765R1 1/2" x 3" 13.95
- 46-766R1 1/2" x 4" 14.50



LIGHT DUTY HINGES

Polished 316 stainless steel. 1/16" thick. Will accept #6 and #8 screws.

- 46-323R.....1 1/2" x 3"5.50
- 46-675R.....1 1/2" x 3 3/4"5.99



STAINLESS STEEL TEE HINGE

Heavy duty, Good quality. Countersunk for #10 screws.

- 46-1304R.....3 1/4" x 5 1/2"44.95



MEDIUM DUTY SHORTSIDE HINGES

Polished 316 stainless steel. 1/8" thick. Countersunk for #8 screws.

- 46-763R1 1/2" x 2 1/4"15.50
- 46-764R1 1/2" x 3"15.95



LIGHT DUTY HINGES

Polished 316 stainless steel. 1/16" thick. Countersunk for #6 screws.

- 46-674R.....1 1/2" x 2 3/8"5.50
- 46-088R.....1 1/2" x 3 3/8"5.25



CUPBOARD DOOR HINGE

#304 Stainless Steel. Requires #10 screws.

- 46-052R.....Flush Mount 2 9/16"H x 1 7/8"L3.95
- 46-053R.....5/16" Offset 2 9/16"H x 2 1/4"L4.95



LIGHT DUTY HINGES

Polished 316 stainless steel. 1/16" thick. Flush type and offset type available. Countersunk for #8 screws.

- 46-434RFlush 1 1/2" x 1 1/2"3.95
- 46-322R.....3/8" Offset x 1 1/2" x 1 1/2"4.75



CUPBOARD DOOR HINGES

2 3/4" x 2 1/8". Use #6 screws.

- 46-071RFor inset installation43.75 pr
- 46-072R.....Flush mount43.75 pr



MEDIUM DUTY BUTT HINGES

Polished 316 stainless steel. 1/8" thick. Barrel ends closed. Countersunk for #8 screws.

- 46-760R.....1 1/2" x 1 1/2"14.95
- 46-761R2" x 2"15.95



LIGHT DUTY STRAP HINGE

Polished 316 stainless steel. 1/16" thick. Countersunk for #8 screws.

- 46-321R.....1 5/8" x 6 7/8"7.50



CONTINUOUS HINGES (6 FT)

Polished stainless steel. Drilled with 1/4" dia. holes.

- 46-503R.....1 1/2" x 6'P.O.R.
- 46-504R.....2" x 6'P.O.R.

HEAVY DUTY CONTINUOUS HINGE

3" x 6" #304 stainless, undrilled hinge. 0.060 thick with 3/16" pin.

- 46-310R.....3" X 6'P.O.R.



PULL APART HINGE

Stainless steel, ideal for motor boxes or hatches which cover needs to be removed. Countersunk for # 10 screws. Approximate size 1 1/2" x 3 3/4"

- 46-1302R..... Right Hand29.95/ea.
- 46-1303R.....Left Hand.....29.95/ea.



HATCH HINGE WITH REMOVABLE PIN

Stainless steel. 2 7/8" L. Open width is 2 3/4"

- 46-083R.....29.95



STAINLESS STEEL SHORT SIDE HINGE

- 46-338R.....5" x 1 1/2"6.95



COAT HOOKS

Perko Coat Hook

- 46-063R.....Base 1 1/4" (#6 Screws)..... 8.85

Perko Utility Hook

- 46-054R.....1 1/2" x 3/4" (#6 Screws) 12.40



FLUSH RING CATCH

Chrome plated zinc, bronze spring. Countersunk for #6 screws.

- 46-334R.....2 1/4" x 1 3/8"41.45



FLUSH PULL

Chrome plated, black plastic flange. Spring loaded. Can be mounted horizontally or vertically. Well made and beautifully finished. Countersunk for #8 screws.

- 46-092R.....3 1/4" x 3/4"27.15



SQUARE LATCH

316 Stainless Steel

Heavy duty latch pull. 3 7/8" x 3".

- 46-953R.....64.95



3" ROUND LATCH

316 Stainless Steel

Heavy duty latch pull. 3" diameter.

- 46-952R.....64.95



STAINLESS STEEL SWIVEL EYE PULLEYS

- 46-941R.....3/4" Sheave x 2 1/4" O.L.....18.95
- 46-942R.....1" Sheave x 3 1/8" O.L.....21.95
- 46-943R.....1 1/4" Sheave x 3 3/4" O.L.28.95



NYLON PULLEYS

- 46-724M.....5/16" x 1"11.95
- 46-725M.....3/8" x 1 1/4"15.95
- 46-726M.....9/16" x 2"19.95



Non Stainless Swivel Eye Pulleys

- 46-559R.....3/4" Sheave3.95
- 46-560R.....1 1/4" Sheave.....5.95



STAINLESS STEEL FENDER ROPE HOLDERS

Takes #6 Screw. Appr. 1 1/4" H x 1 1/4" W

- 46-780R.....Fixed.....6.75
- 46-781R.....Snap Eye.....6.95



RING PULL

Hand cast brass, triple chrome plated. Often used on lighter hatches as a lift.

- 46-086R.....2 1/2" x 1 7/8"12.95



Dock Edge Dock Floats

Howell 260

The Howell 260 has a floatation capacity of 260 lbs.
 Dimensions: 24" x 48" x 8" high
 Weight: 21 lb

46-1700K..... 179.00

Howell 400

The Howell 400 has a floatation capacity of 400 lbs.
 Dimensions: 24" x 48" x 12" high
 Weight: 23.5 lb

46-1702K..... 209.00

Howell 550

The Howell 550 has a floatation capacity of 550 lbs.
 Dimensions: 24" x 48" x 16" high
 Weight: 40 lb

46-1703K..... 319.00



Small "P" Profile



"P" Profile

AIR CUSHIONED DOCK BUMPER SYSTEM

These Profiles are constructed of marine grade flexible PVC, developed not to chip or crack under normal usage. Unaffected by oil, gas or salt water. UV Inhibitors and Fungicides prevent fading, yellowing, deterioration from sunlight and unsightly blotching. Protect your investment with a durable "fender soft" Protection System. Easily installed on any horizontal or vertical surface. Large "P" section with large air volume provides excellent protection.

46-1734K..... Small "P" 2 1/4" x 8' 39.95 46-1733K..... "P" Profile 4" x 8' Length 89.95



SMALL "P" PROFILE CONNECTORS

TConnect AIR CUSHION Profiles for a seamless appearance. **4 per pack.**

46-1765K.....Bumper Connector 14.95
 46-1766K.....90 Degree Corner 24.95
 46-1767KBumper End Cap 16.95
 46-1740KPVC Cement (118ml)..... 11.50

"P" PROFILE CONNECTORS

TConnect AIR CUSHION Profiles for a seamless appearance. **2 per pack.**

46-1737K.....Bumper Connector 10.50
 46-1738K.....90 Degree Corner 18.95
 46-1739KBumper End Cap 12.95
 46-1740KPVC Cement (118ml)..... 11.50

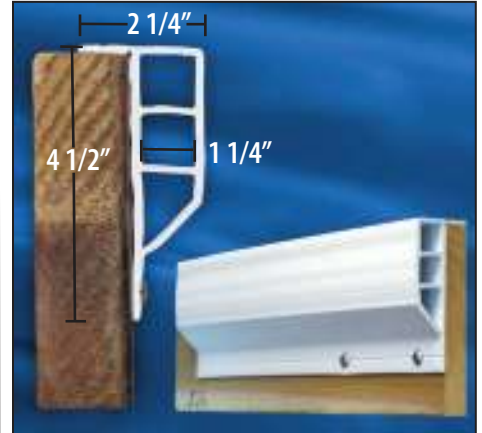

FULL FACE DOCK BUMPER SYSTEM

Ideal for larger applications, this Profile provides extra strength and security against damage to boats or property. Double internal channels with cross girder adds additional protection from impacts and provides a large contact area.

46-1735K.....2 1/4" x 8' Length 64.95



FENDER WHEELS

9" & 12" Smooth rolling wheels offer substantial dock cushioning and feature molded-in valves to adjust the level of firmness. Heavy-duty Hot Dipped galvanized hardware mounts securely to the dock.

46-1730K.....9" 99.95
 46-1732K.....12" 179.95



ULTRAGARD™

Offers the ultimate in cushioning impacts from your boat. Molded in ribs on the interior of the UltraGard™ ensure it is very soft, but durable and will not collapse. The back has a slight radius allowing for easy mounting on pilings as well.

Measures 35" x 2 1/4" x 5"
 46-1745K..... 48.95

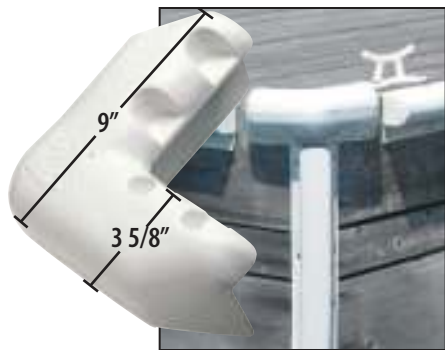

CORNER BUMPER

Protect your vessel from damaging impact with dock corners. This air-filled bumper is constructed from nylon reinforced vinyl and features a built-in air valve for inflation or deflation if necessary.

46-1741K12" x 12" 44.95



DOCKSIDE™ BUMPERS

Protect your vessel from damaging impact with dock corners. This air-filled bumper is constructed from nylon reinforced vinyl and features a built-in air valve for inflation or deflation if necessary.

46-1744K12" x 12" Corner Bumper..... 73.95

46-1743K8 1/2" x 24" Straight Bumper 109.95



CLEAT LITE™

These solar lights are mounted on top of a sturdy galvanized steel base, housed inside an attractive Colonial style 12" tall, 4" wide vinyl pillar. Easy to install and NO WIRES. The lamp is designed to illuminate your boat, dock and stainless steel cleat, and not shine in your eyes. Each kit includes, pillar, stainless steel cleat, galvanized mounting base, solar light and REPLACABLE rechargeable batteries.

46-1757K 126.95



HEAVY DUTY ALUMINUM DOCK LIGHT

Light up your dock, deck or pathways with this attractive, matte finish high-intensity aluminum Solar Dock Lite. Corrosion resistant aluminum. Bright white LEDs. Traffic tolerant, toe friendly design. Rechargeable IP 65 waterproof.batteries.

46-1761K 44.95



DOCK LITE™

The wireless solar DockLite is easy to install. It's durable, weatherproof low profile construction makes it an attractive and functional addition to Docks, Walkways, Decks and Landings. Ideal for illuminating trouble spots on pathways or transition areas such as from dock to shore. With extended duty solar charged batteries the DockLite will last until sunrise. Automatic on-at-dusk. Easily withstands pedestrian and moderate vehicle traffic such as hand carts and more. 4" x 4 1/2"

46-1758K 35.95



SENTINAL SOLAR DOCK LIGHT

Each Solar Sentinel™ incorporates stylish, durable solar lighting on an attractive, broad-based, tapered pillar to illuminate docking areas. The Solar Sentinel™ also has the capability of acting as a Life Ring station. The optional Stainless Steel "J" hook (50-015, page 268) can securely keep a Life Ring under the convenient illumination of the Solar Sentinel™ by day or through the darkest hours of night. Includes solar light, tapered pillar and replacable rechargeable batteries.

46-1756K 164.95



DOCKLITE VALUE PACK

This value pack of solar DockLites is easy to install. The durable, weatherproof low profile construction makes them an attractive and functional addition to docks, walkways, decks and landings. Ideal for illuminating trouble spots on pathways or transition areas such as from dock to shore. Automatic on-at-dusk. Weatherproof and durable. Install easily with NO wires. Traffic tolerant, toe friendly design.

46-1762K 50.95 pk/2



POST LITE™

Powerful solar charging capacity with 360° light diffusing Polycarbonate lens and convex interior reflector maximize light output. Each PostLite™ Fits Post Sizes: 1-5/8", 1-7/8", 2-3/8" OD, and 3-1/4" ID as well as Flat Surfaces with the INCLUDED adaptors. 6 Preinstalled LED colors and convenient toggles built right into the circuit board means you can change colors with the flip of a switch to match a particular color scheme or merely differentiate your dock from your neighbours. Rechargeable REPLACABLE batteries included

46-1759K 93.95 pk/2



LED SOLAR POWERED DOCK LIGHT

12VDC. 4" x 4". Use solar power to charge the battery during daytime and turns ON automatically at night

30-192R24.95

Galvanized Floating Dock Hardware

• 1/4" thick • 9/16" square holes with 3 1/2" from centre to centre.



INSIDE CORNER

For lighter duty applications where an outside corner is not necessary.

46-1711K 5 7/8" Leg length 23.95

OUTSIDE CORNER

Use with backer plates or inside corners at outside ends of docks.

46-1710K 10" Leg length 38.50



SIDE PIPE HOLDER

Bolts to side of dock frame to anchor it in place yet allows vertical movement for water variances.

3" I.D. x 7" long pipe.

46-1722K 7 1/2" Leg length x 5 1/4" H 59.95



DOCK EDGE PIPE AUGER

Pipe auger. Fits up to 2" O.D. pipe. Galvanized

46-1724K 34.95



FEMALE CORNER HINGE

Used with all styles of Male Connector Hinges.

46-1714K 10" Leg length 58.95

MALE CORNER HINGE

Use with all styles of Female Connector Hinges.

46-1713K 10" Leg length 53.95



ANCHOR CHAIN INSIDE CORNER

Offers maximum corner strength when used with Outside Corner or any corner connecting hinge. Holds up to 1/2" chain.

46-1712K 8 1/4" length 45.95

CHAIN RETAINER

Holds chain up to 1/2" to secure the dock in position.

46-1717K 6" L x 5 1/2" H 43.95



INSIDE JOIST CORNER

Use to mount stringers with washer plates. Also use as a backer plate to prevent cleats from pulling out.

46-1723K 2 1/2" Leg length 12.95

BACKER PLATE

Used to sandwich wood framing when another piece of hardware isn't used. Prevents bolt loosening and pull through.

46-1720K 5 1/4" x 5 1/4" (1/8" Thick) 9.50



FEMALE TEE CONNECTOR

Used with all styles of Male Connector Hinges.

46-1716K 5 1/4" length 26.95

MALE TEE CONNECTOR

Use with all styles of Female Connector Hinges.

46-1715K 5 1/4" length 20.95



3/4" CONNECTOR PIN

Used to join male and female connectors.

46-1718K 3/4" Dia 11.95

WASHER PLATE

Used on side of pipe holders, joist corners and chain retainers.

46-1719K 5 1/4" x 1 1/2" 6.50

**SHOP 24/7 FROM
THE COMFORT OF
YOUR OWN HOME**

- Up to date Pricing
- New Products
- Stock Status
- Additional product info
- And more



www.mercersmarine.com



DEPRESSED CENTER GRINDING DISC

Depressed centre. MPA standard. Grinding disc for metal.

- 80-160M4.5" x 1/4" x 7/8"1.95/ea.
- 80-161M5" x 1/4" x 7/8"2.50/ea.



SAW BLADE FOR WOOD

Flat centre. Cutting disc for metal.

- 52-1000M7 1/4" x 30T15.95/pk of 2.
- 52-1001M7 1/4" x 40T17.50/ea.
- 52-1002M7 1/4" x 60T19.50/ea.
- 52-1003M8 1/4" x 24T16.50/ea.
- 52-1004M8 1/4" x 60T25.50/ea.
- 52-1005M10" x 40T28.95/ea.
- 52-1006M10" x 60T28.95/ea.
- 52-1007M12" x 60T45.50/ea.



ASSORTED BOAT/DECK BRUSHES

A selection of cleaning brushes compatible with wooden handle #52-173. Colours may vary.

- 54-045MTampico Head17.95
- 54-046M8" Water Brush - Soft27.50
- 54-050MRound Flow Through - Poly10.50
- 54-052MTruck Brush 10" - Teflon18.50
- 54-054M10" Deck Brush29.95



FLAT CENTER ABRASIVE METAL CUTTING DISC

Double Fiber. Flat centre. Cutting disc for metal.

- 80-154M14" x 1/8" x 1"7.95/ea.



WIRE WHEEL BRUSH

(Crimped Wire Type)

For bench grinders. Medium to heavy duty brush application. Supplied with plastic adaptors to convert arbor hole to 1/2", 5/8", 3/4", 7/8", and 1". Fits arbors from 1/2" to 1 1/4". 6000 RPM's

- 80-123M6" Dia x 3/4" Face25.95/ea.
- 80-124M6" Dia x 1" Face27.95/ea.



DECK BROOMS

Coarse sweep. 0.030 polypropylene. Sold without handles.

- 20-180M18"17.95
- 20-181M24"24.50

54" WOODEN HANDLE

- 52-173M4.29



FLAT CENTER ABRASIVE METAL CUTTING DISC

Flat centre. Cutting disc for metal.

- 80-150M4.5" x 3/64" x 7/8"1.25/ea.
- 80-151M4.5" x 3/64" x 7/8"11.25/10 pk.
- 80-152M5" x 3/64" x 7/8"1.75/ea.
- 80-153M5" x 3/64" x 7/8"14.95/10 pk.
- 80-155M7" x 1/8" x 7/8"3.50/ea.



3M RESINITE PRE-CUT GOLD PAPER

A premium quality sanding paper giving superior cutting & longer life. 9" x 11".

- 80-020R40 Grit1.49
- 80-021R80 Grit1.49
- 80-022R100 Grit1.49
- 80-023R120 Grit1.49
- 80-024R150 Grit1.49
- 80-025R180 Grit1.49
- 80-026R220 Grit1.49
- 80-027R240 Grit1.49
- 80-028R320 Grit1.49
- 80-029R360 Grit1.49
- 80-030R400 Grit1.49



HEAVY DUTY SQUEEGEE - CURVED HEAD

Floor squeegee-rubber blade(head only). Zinc plated frame. Handle socket designed for tapered handle. Can be used with handle #52-173 with wood screw. Ideal for use on concrete floors.

- 20-182M24"16.95





FIBERGLASS MAT

13.8 oz. Per Running Yd. x 50" Wide (Commonly called 1.5 oz)

Packaged Mat by the Yard

- 52-101A50" x 1 Yard.....P.O.R
- 52-102A50" x 2 Yards.....P.O.R
- 52-103A50" x 4 Yards.....P.O.R
- 52-104A50" x 6 Yards.....P.O.R
- 52-105A50" x 10 Yards.....P.O.R
- 52-106A50" x 15 Yards.....P.O.R

By the Full Roll

- 52-182A.....Sold by Kg.....P.O.R.



FIBERGLASS WOVEN ROVEN

24oz. x 50" wide

- 52-113ABy the YardP.O.R.

By the Full Roll

- 52-183A.....Sold by Kg.....P.O.R..

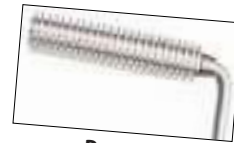

Regular



Bubble Buster



FIBERGLASS STEEL ROLLERS

A tool designed for laying up fiberglass. Eliminates air bubbles.

Regular Type

- 52-116K3" (3/4" Dia)21.95
- 52-117K6" (3/4" Dia)23.95

Bubble Buster

- 52-118K3" (3/4" Dia)21.95
- 52-119K6" (3/4" Dia)23.95



FIBERGLASSING SUPPLIES

POLYESTER "FIBERGLASS" RESIN

Good quality resin used by most Professional Boatyards.

- 52-224A1.9lbs (Qt)P.O.R.
- 52-225A7.5lbs (Gal)P.O.R.
- 52-226A55lbs(5 Gal).....P.O.R.



GELCOAT - (Brushable)

White

- 52-218A2.3lbs (Qt)P.O.R.
- 52-219A9.5lbs (Gal)P.O.R.

LIQUID HARDENER (Catalyst)

For use with Resin/Gelcoat above.

- 52-227A (For Quart)P.O.R.
- 52-228A (For Gal)P.O.R.
- 52-229A..... (For 5 Gal).....P.O.R.



Medium Grey

Medium Grey

- 52-221A.....2.3LBS (Qt)P.O.R.
- 52-222A.....9.5LBS (Gal).....P.O.R.

ACETONE

- 52-056K.....Qt.....P.O.R.
- 52-057K.....Gal.....P.O.R.



F-26 PolyFair Putty

Fast setting polyester based Fairing Compound.

- 52-454A..... Gal.....P.O.R.
- 52-455A.....Qt.....P.O.R.



ROLLER & TRAY SET

Multi-Purpose Plastic Tray Kit. Contains: 240mm x 10mm Multi Purpose Roller, 240mm Consumer Cage Frame, 1L Black Plastic Tray

- 52-239M.....13.49



STANDARD DUTY PLASTIC PAINT TRAY

Similar to others on page, only lighter quality. Paint application only. 2 litre size, c/w legs.

- 52-276M11" x 14" - 2 Litre.....3.49
- 52-277MReplacement Liner1.19



METAL PAINT TRAYS

Standard Duty - Metal

- 52-328M9" x 2 Litre7.95
- Replacement Liner for 2 Litre
- 52-327M1.29



CLIPPER 2 PAINT BRUSHES

Our best selling paint brush. Good quality bristle brush. Plastic blue handle.

52-515M.....	1" (30mm)	2.99
52-516M.....	2" (50mm)	4.75
52-517M.....	3" (75mm)	8.95
52-518M.....	4" (100mm)	10.95



OVATION PAINT BRUSHES

Excellent quality sashes. Blended gold and white polyester. Plastic handle

Flat Sash

52-132M.....	1 1/2"	2.59
52-133M.....	2"	3.19
52-134M.....	3"	4.59
52-135M.....	4"	6.09

Angled Sash

52-136M.....	1 1/2"	2.89
52-137M.....	2"	3.39
52-138M.....	2 1/2"	3.89



CLIPPER 1 PAINT BRUSHES

A good economical bristle brush. Plastic yellow handle.

52-507M.....	1" (30mm)	2.49
52-510M.....	4" (100mm)	8.95



ROLLER HANDLE WITH REFILL

Economy roller & refill. 3" x 5mm roller with wire frame handle.

52-178M.....		1.69
Replacement Refills		
52-296M.....	3"	0.96



ROLLER REFILLS

We carry a large selection of roller refills for most jobs. Quality refills at reasonable prices.

Economy Model, Plastic Core

52-129M.....	9" x 10mm	1.89
--------------	-----------------	------

Lint-Free Model, Plastic Core

52-357M.....	3" x 5mm (pk of 2)	2.59
52-358M.....	3" x 10mm (pk of 2)	2.95
52-359M.....	4" x 5mm (pk of 2)	3.09
52-360M.....	4" x 10mm (pk of 2)	3.39
52-293M.....	7" x 5mm	2.39
52-288M.....	7" x 10mm	2.69
52-294M.....	9" x 5mm	2.79
52-289M.....	9" x 10mm	2.89
52-295M.....	9" x 13mm	3.09
52-298M.....	9" x 20mm	3.79



CAGE FRAMES

Good quality dynamic Frame. Plastic handle. Will accept threaded pole.

52-267M.....	3"	1.99
52-362M.....	4"	2.09
52-130M.....	7"	2.29
52-131M.....	9"	2.59



EXTENSION POLE

54" Hardwood handle. Threaded on one end to accept cage frames on this page.

52-173M.....		4.29
--------------	--	------



DYNAMIC FOAM ROLLERS, HANDLES & TRAYS

52-006M.....	4" Roller/Handle/Tray Combo.....	5.79
52-007M.....	4" Foam Rollers (2 pk).....	3.29
52-008M.....	6" Foam Rollers (2 pk).....	4.19
52-009M.....	4" Plastic Tray.....	1.89
52-010M.....	4" Foam Roller with Handle.....	3.99
52-011M.....	Roller Handle for 4" & 6".....	1.79



DROP SHEET DISPENSER

High density clear plastic. Lighter and tougher. Easy to tape. Resist bleed through. 9' x 400'

52-013K.....		27.95
--------------	--	-------



PLASTIC PAINT PAIL

Has measurement marks in litres and quarts. 5 Quarts.

52-012K.....		3.95
--------------	--	------



METHYL HYDRATE

Guaranteed pure; use for thinning shellac. Excellent fuel for alcohol stoves. Smokeless when burned.

52-014M.....	946 ml.....	9.49
52-015M.....	3.78 L.....	17.49

Interlux **NEW**



BOTTOMKOTE - CA

Bottomkote-CA uses ablative action to provide premium season to season protection against barnicles, zebra muscles and algae in all waters. Ideal for boatyards and boaters looking for a high solids antifouling that can be applied at lower temperatures (as low as 5°C) providing more flexibility in the painting schedule. Compatible over most antifoulings.

QUARTS

54-010M.....Red.....	71.00
54-011M.....Blue.....	71.00
54-012M.....Black.....	71.00

GALLON

54-015M.....Red.....	213.00
54-016M.....Blue.....	213.00
54-017M.....Black.....	213.00

PETTIT



PETTIT ULTIMA HYBRID ANTI-FOULING PAINT

Hybrid paint film offers all the advantages of hard and ablative paints. Unique controlled erosion minimizes build up yet stands up to seasonal abuse. Hybrid technology reduces the need for sanding. Can be painted up to 12 months before launching Coverage : 400 sqft/gal.

QUART

54-070M.....Black.....	99.00
54-071M.....Blue.....	99.00

GALLON

54-074M.....Black.....	334.00
54-075M.....Blue.....	334.00
54-076M.....Red.....	334.00

PLEASE NOTE:

We are unable to ship Paint in the Mail.

Interlux



MICRON CSC PAINT

Uses Micron® Technology to provide excellent, long lasting antifouling protection against all types of fouling. Controlled polishing rate reduces build-up of old coatings and minimizes sanding. Haul and re-launch without repainting. Micron Technology uses less copper more efficiently than old fashioned high copper bottom paints. Suitable for all power and sail, in all waters. Proven performance for over 20 years. Lloyds Register certified as TBT-free. Coverage : 110 sqft/qt.

QUART

54-000M.....Blue.....	109.95
54-001M.....Red.....	109.95
54-002M.....Black.....	109.95
54-003M.....Shark White.....	109.95

GALLON

54-005M.....Blue.....	385.00
54-006M.....Red.....	385.00
54-007M.....Black.....	385.00
54-008M.....Shark White.....	385.00

3M



3M HIGHLAND MASKING TAPE

General purpose tape from 3M. 60 yd. rolls.

56-065R.....3/4".....	7.95
56-067R.....1 1/2".....	15.95
56-068R.....2".....	13.95



WIRE BRUSHES WITH SCRAPER

Extra long wooden handle, 4 wire. Bristle size, 7 3/4" x 1 1/2".

52-297M.....	3.95
--------------	------

PETTIT



PETTIT UNEPOXY HRT ANTI-FOULING PAINT

Unepoxy HRT seasonal antifouling uses the latest technology available to create a hybrid paint film strong enough to handle the tough marine environment without building up over time. Maintains uniform color consistency, and lower weight while providing a smoother finish than traditional paints. Coverage : 500 sqft/gal.

QUART

54-060M.....Black.....	76.95
------------------------	-------

GALLON

54-064M.....Black.....	238.00
54-065M.....Blue.....	238.00
54-066M.....Red.....	238.00



DISPOSABLE COVERALLS

Heavyweight polypropylene coveralls. Hood, elastic wrists and ankles. Zipper.

WHITE

52-793M.....Med.....	7.95
52-794M.....Lg.....	7.95
52-795M.....XL.....	7.95
52-796M.....2X.....	7.95
52-797M.....3X.....	7.95
52-798M.....4X.....	7.95
52-799M.....5X.....	7.95

Paint & Accessories

MARINE EQUIPMENT



INTERLUX "BRIGHTSIDE" POLYURETHANE FINISHES

Brightside Polyurethane is the most technically advanced one-part polyurethane available. Brightside now contains Teflon® for better resistance to staining, abrasion and easy cleaning.

Brightside uses Polyflow 4000®, a unique polyurethane resin, which yields excellent flow and leveling characteristics as well as incredible abrasion and chemical resistance. Brightside also takes advantage of the latest in ultraviolet technology which insures longer color and gloss retention. Together, these technologies create a one-part polyurethane which gives the look of a two-part polyurethane with the application ease of a one-part enamel.

Coverage : Brush-130sqft/qt. Spray-85sqft/qt.

Applications: Fiberglass, Epoxy, Wood and Bare Metal. Contact us for an application guide for each of these products.

U.S. Quart

54-500PWhite 435962.50
54-501POff White 438162.50
54-502PLargo Blue 410067.95
54-503PYellow 415267.95
54-504PKingston Gray 419067.95
54-505PSeattle Gray 420567.95
54-506PBristol Beige 420767.95
54-507PG. Banks Beige 421767.95
54-509PSundown Buff 423767.95
54-510PSapphire Blue 424167.95
54-511PSea Green 424767.95
54-512PFire Red 424867.95
54-513PSteel Gray 425067.95
54-514POcean Blue 425367.95
54-515PBlack 425867.95
54-516PDark Blue 431667.95
54-517PLight Blue 435167.95
54-518PMedium Blue 435367.95
54-520PHatteras Off-White 420867.95
54-521PBlue-Glo White 425962.50
54-522PMatterhorn White 436062.50
54-523PFlag Blue 499067.95
U.S. Gallon		
54-525PWhite 4359195.00



White 4359		Light Blue 4351	
Off-White 4381		Medium Blue 4353	
Seattle Gray 4205		Largo Blue 4100	
Kingston Gray 4190		Ocean Blue 4253	
Steel Gray 4250		Sapphire Blue 4241	
Black 4258		Dark Blue 4316	
Sundown Buff 4237		G.Banks Beige 4217	
Sea Green 4247		Bristol Beige 4207	
Yellow 4152		Fire Red 4248	
Matterhorn White 4360		Flag Blue 4990	
Hatteras Off-White 4208		Blue-Glo White 4259	

PLEASE NOTE
Colors may not be exactly as shown.



FLATTENING AGENT YMA715CA

Used to remove the high gloss from Brightside finishes if desired.

54-555PU.S. Qt.59.95
---------	---------------	------------



INTERDECK (NON-SKID DECK FINISH)

An excellent, easy to apply slip resistant polyurethane finish for decks. Interdeck contains a fine aggregate and will apply easily on all substrates. Interdeck gives a low sheen finish that helps protect against dazzle from sunlight reflected off decks. The tough polyurethane resin protects decks against everyday wear and tear.

Coverage : 95 sqft/qt.

Quart

54-543PWhite63.95
54-545PGrey63.95
54-546PBeige63.95



MARINE OIL PAINT

Interior/Exterior alkyd marine paint for wooden, metal, or fiberglass surfaces exposed to marine environment and saline sea spray. Resistant to fresh and salt water.

Coverage : 400 sqft/gal.

GALLON

54-240HWhiteP.O.R.
54-244HBattleship GreyP.O.R.

PLEASE NOTE:
We are unable to ship Paint in the Mail.





MAT-GLO FLUORESCENT ENAMEL

Interior/Exterior daylight fluorescent alkyd enamel for application where high visibility is required. ideal for use as a safety marking, and for use on fire protection and life saving equipment, buoys and navigational aids. We recommend use of an undercoater before applying. 1 Litre can. Coverage : 100 sqft/qt.

54-270K.....Flame Orange	42.95	54-274K	Impact Yellow	42.95
54-271K.....Fire Red	42.95	54-275K.....	Ember Pink	42.95
54-272K.....Flare Orange	42.95	54-276K.....	Lightning Yellow.....	42.95
54-273K.....Signal Green	42.95	54-279K.....	Horizon Blue.....	42.95



Because of limitations of printed reproduction, colours may not accurately match the bright, fluorescent colours.



BILGEKOTE BILGE PAINT

Bilgekote is a fast drying, durable coating formulated for application to bilge areas. Helps prevent absorption of oil, gasoline or sludge into wood and fiberglass.

54-580P.....White - Quart	46.00
54-581P.....Grey - Quart	46.00



2316 SPRAY THINNER

Reducing Solvent 2316N is a fast evaporating solvent for use in specific two-part polyurethane and epoxy products.

54-562P.....Quart.....	28.95
------------------------	-------



INTERPROTECT 2000E

Interprotect 2000E with Microplates is a unique two-part epoxy coating developed to protect fiberglass hulls from water absorption, which can lead to osmotic blistering. Microplates create an overlapping barrier to help stop water migration through the coating. The Interprotect system is the system of choice for repairing gelcoat that has already been damaged by osmotic blistering. Interprotect 2000E can be used above and below the waterline as a universal primer for all surfaces and has proven itself to be an excellent primer for all metals.

54-574P.....White - Quart	60.95
54-575P.....White - Gallon.....	184.95



PRIMOCON

Primocon is an anticorrosive primer for underwater metal surfaces (including hulls, running gear, and the lower units of outboards and I/O's). It will provide an excellent barrier to reduce pitting of the metal from galvanic corrosion. For underwater Aluminum use Tri-Lux II.

54-578P.....Quart.....	47.95
54-579P.....Gallon.....	149.95



#2333 BRUSH THINNER(FOR PERFECTION)

2333N Reducing Solvent is a slow evaporating solvent to be used in specific two-part polyurethane and epoxy products. Refer to the specific product directions for the amount of Special Solvent Reducer to add.

54-560P.....	36.95
--------------	-------



NO SLIP COMPOUND

A simple additive that you sprinkle onto any surface, inside or out, while the paint is still damp that gives it texture to make the surface a little safer to stand on.

52-304P.....200g.....	7.49
-----------------------	------



CETOL MARINE

A durable translucent satin protective wood treatment, formulated with a special alkyd resin and high quality synthetic UV-absorbing pigments. Produces an attractive golden tint to hardwoods. For interior or exterior use. Coverage : 90sqft/qt.

- 54-595PQuart.....58.95
- 54-596PGallon.....182.00

CETOL MARINE GLOSS

A durable clear gloss protective exterior wood treatment, developed as a topcoat for Cetol® Marine.

- 54-598PQuart.....63.95



BRIGHTSIDE THINNERS (FOR BRIGHTSIDE)

For thinning & cleaning Brightside finishes.

- 54-556P#333 Brushing Thinner / Qt.....28.95
- 54-558P#216 Spraying Thinner / Qt.....25.95



SOLVENT WASH #202 (FOR BRIGHTSIDE)

For cleaning fiberglass and epoxy surfaces, prior to applying brightside finishes.

- 54-563PQt28.95
- 54-564PGal69.95



BRIGHTSIDE PRIMER (PRE-KOTE) #4279

Recommended for use on fiberglass and wood, before applying Brightside polyurethane finishes. Coverage 100 sqft/qt. Color: White.

- 54-550PU.S. Qt49.95
- 54-551PU.S. Gal.....159.95



ORIGINAL SPAR VARNISH

Original is a traditional spar varnish that combines ease of application with good gloss and durability. Ease of use and traditional golden color make Original an ideal choice for use on interior and exterior woodwork such as cabin trim, handrails and coamings. Coverage : 125 sqft/qt.

- 54-573PY90 (Quart).....34.95



EPOXY BARRIER - KOTE

Recommended for use over epoxy resins, prior to applying Brightside finishes. 2 part resin and hardener system.

- 54-566P#404 Qt Total Volume.....56.95



TEAK CLEANER

This non-acidic formula removes stains and restores weathered teak in one easy step. Does not raise wood grain like acid based teak cleaners. Great for teak and all other fine woods. Safe and easy to apply, brush on with light scrubbing action and hose off.

- 52-311R.....32 oz32.50



TEAK BRIGHTENER

Brightens teak and other fine woods. Highlights wood grain and enhances warm natural color. Use as the second step in the restoration of grey weathered teak. Easy to use - just apply and rinse. No rubbing or scrubbing required.

- 52-312R.....32 oz31.45



PREMIUM GOLD TEAK OIL

Lasts much longer than other teak oils. Space age polymer and tung oil formula make this product superior. Gives natural warm golden color.

- 52-086RQuart.....48.95
- 52-087RGallon.....139.95





SIERRA TC-W3 OIL (FOR 2-STROKE)

Sierra TC-W3 is a high performance lubricant that has been manufactured and designed to meet and exceed all (Domestic & Import) engine manufacturers warranties. Exceeds JASO, ISO, API and NMMA, for advanced generation 2 cycle lubricants.

- Ideal for oil injection systems or pre-mix applications.
- Optimum burnability for smokeless combustion. Runs cleaner, burns cleaner.
- Significantly reduced aquatic toxicity to fish compared to other outboard oils on the market today.
- Maximum lubrication and detergency allows engine to run smoother and more efficiently.

90-250RPint.....	10.95
90-251RQuart.....	16.75
90-252RGallon.....	60.95
90-253R2.5 Gallons.....	138.95



SIERRA TC-W3 OIL (FULL SYNTHETIC)

Sierra Full Synthetic TC-W3 has been designed for use in all outboards including Johnson/Evinrude E-Tec. So when you want the ultimate protection for your engine, Sierra Full Synthetic is there to handle the job.

90-258RQuart.....	24.95
90-259RGallon.....	91.95



SIERRA PREMIUM GEAR OIL

Recommended for all general marine applications requiring a GL-5 class lubricant. Formulated for use in freshwater or saltwater conditions and all standard marine applications. Reduces friction and protects gears, bearings and other gearcase components.

90-270RQuart.....	16.50
---------	-----------------	-------



SIERRA FUEL STABILIZER

Gasoline performance additive and stabilizer. Promotes quick starting. Keeps carburetor and fuel system clean. Reduces gum and varnish build up. Improves engine performance. Stabilizes gasoline without ethanol up to 24 months. 1/4 oz. per gallon for everyday use or 1/2 oz for storage. A 8 oz bottle will treat either 32 gal. for everyday use or 16 gal. for storage.

90-295R8 oz.....	10.95
90-296RGallon.....	86.95



SIERRA SYNTHETIC GEAR OIL

Specially formulated for use in high-performance outboard and stern drive applications. It shares many of the same advanced properties as Sierra's Synthetic Engine Oil, making it a superior choice for longlasting protection of critical drive components. Its enhanced lubricity does a better job of reducing friction and prolonging the life of internal parts than conventional oils. Offers superior corrosion protection, making it an ideal choice for boats that see frequent use in salt water.

90-272RQuart.....	27.95
---------	-----------------	-------



SIERRA 10W-30 PREMIUM OIL

4 stroke marine outboard engine oil is a highly refined petroleum formulated with premium base stock and highly refined additives. Specifically formulated to meet or exceed the tough requirements of the Marine 4 stroke motor. Excellent anti-wear characteristics. Reduces friction. Formulated to offer maximum corrosion protection. Reduces sludge, keeps engine cleaner for better efficiency. Low temperature viscosity offers better cold starting.

90-264RQuart.....	14.50
90-265RGallon.....	50.95



SIERRA 10W-30 PREMIUM OIL

Formulated specifically for 4 stroke outboard and sterndrive engine technology. A special blend of synthetic base oil and a balanced additive system that exceeds requirements for marine engine oils. Recommended for use in both outboard and sterndrive applications. Offers faster lubrication at start up in low temperatures, excellent protection at high temperatures, and greater resistance to oxidation for lower oil consumption.

90-267RQuart.....	23.95
90-268RGallon.....	88.95



SIERRA POWER TRIM AND TILT FLUID

Formulated for high operating pressure. Anti-foam additives assure uniform flow with reduced air contamination in hydraulic systems. Designed for heavy duty use at high operating pressures in applications subject to varied tempature ranges. Provides proper lubrication and corrosion protection for internal hydraulic components.

90-293R10 oz.....	8.99
---------	-----------------	------



SIERRA PREMIUM 25W-40 OIL

25W-40 4 stroke marine stern drive engine oil has been formulated to provide excellent lubrication and corrosion protection. Stern drive and inboard engines operate under high load and running stresses. This product is developed for the marine environment and will out perform standard 4-cycle automotive engine oils. It offers excellent detergency, anti-oxidants, antiwear, and corrosion protection. Reduces wear to the internal components, protects internal parts from corrosion, cleans pistons, and prevents ring sticking. Excellent low temperature operating properties

90-275RQuart.....14.95
 90-276R.....5 Quart71.95



SIERRA 15W-40 DIESEL OIL

Meets the Following Manufactures Specifications: Volvo Vds-3; Cummins Ces20078, Ces20077, Ces20076; Detroit Diesel Ddc93d214; Cat Ecf-2, Ecf-1; Global Dhd-1. Increased Detergency Fights Soot and Carbon Deposits. Certified To Api CI-4+ Rating. Meets Highest Standards for Diesel Oil.

90-282RQuart.....12.50
 90-283R.....5 Quart43.95



SIERRA FULL SYNTHETIC SAE 30 MOTOR OIL

A special blend of synthetic base oil and a balanced additive system that exceeds the FC-W requirements for marine engine oil. Recommended for gasoline and diesel inboard and sterndrive engines. Superior engine protection during startups, operation and storage. Reduces friction and wear for extended engine life. Longer lubrication effectiveness than mineral oils. Reduces oil consumption and improves fuel economy.

90-278RQuart.....17.50
 90-279R.....5 Quart77.95



SIERRA GREASE GUN

This high quality, heavy duty grease gun is designed for years of trouble-free applications. The application nozzle can be removed and a flexible extension hose can be installed for working on hard to reach fittings.

90-290R.... 3 oz Model (Comes w/3oz Grease)64.95
 90-291R..... 15 oz Model (No Grease)52.95



SIERRA LITHIUM SPRAY GREASE

Multi-Purpose spray lubricant for Marine applications. Ideal for lubricating shift components and miscellaneous applications where a light grease lubricant is required. Water and heat resistant. Prevents corrosion

90-285R12 oz.....11.95



SIERRA MARINE PREMIUM GREASE

Specifically formulated for marine applications. Premium lithium formula provides optimum corrosion protection in both freshwater and saltwater applications. Ideal for trailer wheel bearings, universal joints and outdrive pivot joints. Operating Temp -40 to +350F.

90-287R15 oz.....12.50
 90-288RTwo 3 oz Tubes19.50



SIERRA FOGGING OIL

Protects internal engine components from rust and corrosion. Specifically formulated for seasonal storage of outboard & sterndrive engines. Ideal for all 2-cycle and 4-cycle engines.

90-294R12 oz.....12.95

Want to receive e-mail updates from Mercer's Marine?
Subscribe at
mercersmarine.com





The keel of most boats is the center line running down the bottom of your boat. It generally protrudes and slices into the water. Because of this, the keel both slices the water first, and also bumps into concrete, ramps, docks, and rocky shores first. But it doesn't have to. KeelShield was developed to protect your most vulnerable, and constant point of contact. Made of pure Urethane Polymers, this 5" wide rugged shield is the strongest and most durable protection for your keel from abrasions, scratches, and scars.



BOWSHIELD

Guaranteed bow protection from docks, trailer stops and bow rollers.

- Easy, Do It Yourself Installation
- Made of durable 316 marine grade mirror finished stainless steel
- 3 year warranty.
- Prevent costly repairs
- Maintain the value of your boat

90-100PSmall (6.5" x 6")49.95
90-101PLarge (7.5" x 9")59.95



GATORSKINZ

GatorSkinz is a traction and mat material made out of 70% recycled material featuring a black pebble or grit texture. 2 pack of precut step pads that are 16" x 4".

90-104P2 pcs, 16" x 4"29.95
---------	----------------------	------------

6' KeelShield		
90-081PWhite215.00
90-085PBlack215.00
90-089PGrey215.00
8' KeelShield		
90-082PWhite289.00
90-086PBlack289.00
90-090PGrey289.00
10' KeelShield		
90-083PWhite359.00
90-087PBlack359.00
90-091PGrey359.00

NEW



BEBBINGTON AIM DEGREASER

Biodegradable - phosphate free. Industrial strength formula easily removes oil, grease, soot, dirt, grime and black marks that may be resistant to other cleaners.

52-305R650 ml7.95
52-306R4 L17.95

NEW



BEBBINGTON RUST REMOVER

A phosphoric acid-based solution for the removal of rust, tarnish and scale from metal surfaces. Can be used on cast iron, stainless steel, chrome and aluminum.

52-323R750 ml14.95
52-324R4 L38.95



**Shop or Browse
Online 24/7
at
mercersmarine.com**

Boat Care & Maintenance

MARINE EQUIPMENT

NEW



Starbrite

PREMIUM CLEANER WAX

One Step Heavy Duty Cleaner Wax is formulated specifically to remove oxidation and hazing from fiberglass or painted surfaces. The special polymers seal the restored finish to keep it looking its best, while providing unmatched protection against UV rays and a deep, long-lasting gloss. Application is simple, whether by hand or with a buffer.

52-073R.....32 oz.....25.95

NEW



Starbrite

PREMIUM LIQUID RUBBING COMPOUND

Removes stains, medium oxidation and scratches. For fiberglass, metal and painted surfaces. Convenient liquid formula. Great for hand or buffer application. Does not set up like most rubbing compounds so removal is quick and easy.

52-074R.....16 oz.....19.95



Starbrite

BLACK STREAK REMOVER

Instantly removes black streaks caused by water run off. Safe for use on fiberglass, metal and painted surfaces. Just spray on, let work and hose off. Contains no harsh acids or alkali. Cleans by patented process of chelation. Can be used for 1000's of other tough jobs-bathrooms, tubs & showers.

We highly recommend this product!

52-080R.....22 oz.....19.50



Starbrite

TEFLON MARINE POLISH

The ultimate protection for fiberglass •Lasts up to five times longer than regular waxes •U.V. protection, easy on, easy off •Offshore power boat race tested.

52-081R.....16 oz.....33.95



Starbrite

MARINE POLISH

Helps stop fading from UV rays •Equally good for new & older boats •No hard rubbing required •Lasts up to four times longer than other polishes.

52-082R.....16 oz.....25.95



Starbrite

RUST REMOVER

Easy to use spray formula. Requires no rubbing or scrubbing. Safe for use on fiberglass, metal and painted surfaces. Removes rust drip stains and rust deposits.

52-152R.....22 oz.....21.95



Starbrite

BOAT WASH

Biodegradable. Leaves hulls, decks, chrome and fittings sparkling. Non-streaking, does not leave residue. Will not remove wax or polish. Concentrated Heavy-Duty Formula. Powerful - 3 capfuls clean a 7 m boat. Special cleaning agents remove dirt, fish blood, salt deposits, road grime, exhaust smudges, waterline stains and more. Safe for use on all marine surfaces.

52-065R.....16 oz.....11.50
52-066R.....1 Gal.....59.95



Starbrite

ALUMINUM CLEANER/RESTORER

Engineered to bring back unpainted aluminum surfaces that have become dull or stained. Unlike other "all surface" cleaners, this product is formulated specifically for use on aluminum and strips away grime, stains and oxidation without harming the metal.

52-606R.....64 oz.....40.95

NEW



Starbrite

ALUMINUM POLISH

Formulated to preserve the finish of aluminum pontoon boats, canoes and jon boat. PTFE polymers provide UV protection and help repel dirt and stains. Use after Aluminum Cleaner/Restorer to enhance the look of older boats.

52-607R.....16 oz.....24.95



FLAGSHIP PREMIUM MARINE WAX

Dramatically enriches color and shine of fiberglass and gel coat surfaces. Effective in removing light oxidation and dullness, restoring gloss, and adding protection from UV damage. *Use wax only after the surface has been cleaned and restored to a "like new" or "average" finish.

52-730R.....16 oz.28.50
 52-731R.....32 oz.43.95



HI-TECH YELLOW WAX

Provides ultimate high gloss protection to any previously cleaned and polished paint finish. Premium yellow Carnauba wax blended with silicones, polymers and other waxes. Adds richness and depth of color

52-732R.....16 oz.24.95



ONE STEP CLEANER WAX

A non-abrasive formula that cleans, polishes and protects all boats and RV's in one easy step. Removes light oxidation and haze, minor scratches and swirls. Provides long-lasting protection against salt air, corrosion and the sun's ultraviolet rays.

52-734R.....16 oz.24.95



QUIK WAX®

Wax your boat as you dry to create a brilliant gloss and add wax protection. Use on wet or dry surface. Quickly and easily maintains gloss between periodic waxings. Suitable for use on fiberglass, painted surfaces, stainless steel, clear plastic and other non-porous surfaces (Do not use on glass windows). Use wax only after the surface has been cleaned and restored to a "like new" or "average" finish.

52-733R.....16 oz.20.95



ONESTEP COMPOUND

This aggressive, yet safe, one-step compound will clean and restore gloss to the gel coat surface in one step. Removes moderate-heavy oxidation, scratches, stains and tough water spots on all fiberglass and painted gel coat marine or RV surfaces. Restores color and leaves a rich gloss on the treated surface. Incredible results by hand or machine.

52-735R.....32 oz.54.95



MIRROR GLAZE HD OXIDATION REMOVER

Removes moderate oxidation, scratches, stains and tough water spots on all fiberglass gel coat and painted marine or RV surfaces. Restores color by effectively removing surface degradation.

52-737R.....16 oz.22.95



MARINE BOAT WASH

64 oz. economy size. Long lasting suds. Safely removes grime and dirt. Refreshing scent. Biodegradable.

52-745R.....64 oz.13.95



PLASTX CLEAR PLASTIC CLEANER & POLISH

This easy-to-use, rich gel formula quickly restores optical clarity to both rigid and flexible clear plastics. Removes light oxidation, chemical degradation, surface contamination, stains and light surface scratches with ease. Special highly water resistant polymers provide long lasting durable protection to keep your clear plastics clear and beautiful longer.

52-748R.....10 oz.14.95



BOAT/RV PURE WAX

Meguiar's Marine/RV Pure Wax offers a durable high gloss protection for all fiberglass, gel coat marine, or RV surfaces. Blend of pure Brazilian Carnauba Wax with silicones, polymers, and resins to maintain extraordinary gloss and protection. It also protects against the sun's ultraviolet rays.

52-741R.....16 oz.27.95



BOAT/RV POLISH AND GLASS ENHANCER

Restores brilliant gloss on fiberglass and painted marine or RV surfaces after cleaning. Restores valuable oils to feed and nourish the fiberglass or painted surfaces. Especially effective on dark colors. *Use polish only after the surface has been cleaned and restored to a "like new" or "average" finish.

52-739R.....16 oz.22.50



WATER MAGNET MICROFIBRE DRYING TOWEL

Dry your car with as much care as you wash your car with the extra large Meguiar's Water Magnet Microfibre Drying Towel. Waffle texture wrings out easily, making drying more efficient and leaves a spot-free finish on the car's surface. Absorbs up to two times the water of traditional terry towels. Reuseable, simply throw it in the washing machine and reuse it again and again.

Size: 22" x 30"

52-742R.....22.95



MICROFIBER WASH MITT

Meguiar's Microfiber Wash Mitt is the ultimate choice for show car perfect finishes. Super-soft, extra-thick wash mitt lifts and traps dirt, allowing for swirl-free washing. This premium mitt also features a comfort-fit cuff and soft inner lining for comfortable use. 8" x 10"

52-743R.....12.95



VINYL & RUBBER CLEANER

Cleans, revitalizes, and protects vinyl and rubber surfaces in one easy step. Screens out damaging UV rays that can dry out or crack the surface.

52-740R.....16 oz.21.95



3M™ MARINE CLEANER AND WAX

Designed to remove LIGHT to MEDIUM oxidation, clean polish and protect fiberglass/gelcoat. Unique liquid formulation combines a compound with a special blend of waxes which restore shine and protect in one application.

52-062R473ml.....49.95



MARINE BOAT SOAP

Mix with water for desired cleaning strength. Cleans grease, oil, grime, algae, fish blood, and dirt. 3M™ Marine Boat Soap, is a concentrated formula, designed to clean anything from dirty decks to soiled fabrics to degreasing engines.

52-950R473 ml.....31.95

52-951R946 ml.....56.95



INDUSTRIAL GRADE WATER HOSE

Heavy duty machined brass ends. Non-marking, soft and flexible. 300psi. Temp. rating : -26°C to +66°C

38-810K.....1/2" I.D. x 50ft.69.95



3M™ MARINE MILDEW STAIN REMOVER

Quickly removes mildew stains on vinyl, covers, cushions and other marine surfaces.

52-186R500ml.....34.50



3M MARINE ALUMINUM RESTORER & POLISH

Designed to remove oxidation growth and stains and restore a lustrous appearance to bare aluminum. Use sparingly. Also removes heavy oxidation and restores shine to most painted aluminum surfaces.

52-187R.....510g74.50

3M



3M LIGHT CUTTING POLISH

3M's new formula stays wet longer, letting you use less and waste less product. This one-step wonder provides durable, long-lasting shine in less time. Perfect for finish maintenance on marine, RV, and industrial gelcoat surfaces.

- 52-956R473 ml.....49.95
- 52-957R946 ml.....79.95

3M



3M MEDIUM CUTTING COMPOUND

One step compound and wax. Combines medium cutting power with a glossy finish and durable wax. Removes P1000 and finer scratches and protects the surface. Great for marine, RV, and industrial gelcoat surfaces. Stays wet longer so operators can use less, and see easier cleanup.

- 52-952R473 ml.....56.95
- 52-953R946 ml.....109.95

3M



3M HEAVY CUTTING COMPOUND

This improved system makes restoring the beauty of your gelcoat finish faster and easier than ever, with fewer products, fewer steps, and better results. Whether your boat has heavy scratches, heavy oxidation, or light oxidation, there's a Perfect-It Gelcoat finishing product solution that not only removes the scratches and oxidation, but quickly restores the beauty and shine.

- 52-954R473 ml.....72.95
- 52-955R946 ml.....132.95

3M



3M PERFECT-IT BOAT WAX

Use 3M Perfect-It Boat Wax as the final step for any gelcoat, fiberglass, wood, or metal refinishing project where a wax finish is recommended, and high-gloss results are desired. To remove heavy sanding scratches or heavy oxidation from gelcoat surfaces, use 3M Perfect-It Gelcoat Heavy Cutting Compound first (#52-954), then finish with Perfect-It Boat Wax to preserve the shine, and protect the money and time you've invested.

- 52-958R473 ml.....44.95
- 52-959R946 ml.....81.95

3M



3M MARINE PROTECTIVE LIQUID WAX

Designed to provide high gloss and protect fiberglass /gelcoat, marine topside paints, painted aluminum and marine metal parts. Easy on/exceptionally easy off formula which also protects against UV light damage.

- 52-185R500ml.....51.95



MERCER'S

3M



3M™ SUPERBUFF™ POLISHING PAD

Double sided, soft edge polishing pad designed for use with a polisher and glaze. Superbuff™ polishing pad is made with extremely fine fibers to produce a high gloss on paint surfaces. Pad has its own built in, lightweight support system.

- 52-640R.....109.95 ea.

3M



3M™ SUPERBUFF™ BUFFING PAD

A new 100%, double sided, wool pad with a stiffer central hub for more cutting power. This pad has untwisted yarn construction, which allows for more surface contact, while giving excellent cut and finish. Excellent for all paints and clears.

- 52-642R.....91.50 ea.

3M



3M™ SUPERBUFF™ ADAPTOR

Adaptor for the 3M™ Superbuff™ Buffing Pads (PNs 05700,05701,05703, 05704, and 05705). Works with 3M™ Perfect-It™ Backup Pad (PN 05718).

- 52-645R.....29.95



MERCER'S BILGE CLEANERS

Great value in an economical product that works. Used by many commercial and government vessels. Look at the Price!

52-315R.....	1 Litre.....	7.95
52-316R.....	4 Litres.....	18.95
52-317R.....	20 Litres.....	84.95



NO DAMP DEHUMIDIFIER

Dries air to level where mildew cannot grow and stops odors. Unique inner basket design increases efficiency and life of unit.

12 oz. container treats 900 cu. ft. area	
52-600R.....	12oz.....13.50
52-601R.....	36oz.....24.95
52-602R.....	Dehumidifier refills.....5.25



NO DAMP HANGING DEHUMIDIFIER

Protects your boat and home keeping air fresh and clean. Eliminates mildew odors and other musty odors. Helps prevent damage and stains caused by excess airborne moisture.

52-603R.....	11.95
--------------	-------



BILGE CLEANERS

Star brite Heavy-duty

Biodegradable. Work-free, just pour in, run your boat and drain. Dissolves & eliminates oil, grease, gasoline, scum and sludge. Protects against vapor explosions.

52-077R.....	Qt.....	20.95
52-078R.....	Gal.....	52.95



MILDEW STAIN REMOVER

Removes mildew stains on contact. Easy to use. Simply spray on application. Use on vinyl covers, headliners, cushions, etc. Works like magic. Out performs all other stain removers.

52-150R.....	20 oz.....	19.50
--------------	------------	-------



SAIL & CANVAS CLEANER

Biodegradable. Cleans & brightens both whites & colors. Concentrated formula. Safe & easy to use. Removes dirt, grease & mildew stains. Great for boat covers, bimini tops and sails. Does not weaken fabric or threads.

52-085R.....	16 oz.....	15.70
--------------	------------	-------



VINYL CLEANER AND POLISH

Revolutionary new formula cleans and restores all vinyl surfaces while leaving a polymer coating which provides UV protection and a long lasting shine.

52-092R.....	16 oz.....	23.95
--------------	------------	-------



STARBRITE CORROSION BLOCKER

Easy to use, simply spray onto metal surfaces to form a protective, non-sticky polymer barrier. Ideal for protecting outboard engines, trailer bolts, automotive and home use, and more. Will not leave a messy, sticky residue like traditional aerosol lubricants.

52-598R.....	22 oz.....	28.95
--------------	------------	-------



BOAT COVER CLEANER

Special formula removes dirt, stains and light mildew stains from boat covers, bimini tops, sail covers, tarps and t-tops.

52-095R.....	32 oz.....	22.95
--------------	------------	-------



COLOR RESTORER

Brings back original color and luster •Removes heavy oxidation, chaulking and fading •Seals surface to protect against future fading and weathering •Easy to use •Will not scratch or harm gelcoat •Excellent for all dark colored boats.

52-075R16 oz24.95



NON-SKID DECK CLEANER

Cleans away ground-in dirt and stains. Safe to use, contains no harsh chemicals. Leaves a protective coating to help repel dirt and stains. No hard scrubbing or rubbing. Will not remove wax or polish. A very effective, all-surface cleaner for fiberglass, vinyl, plastic, metal and painted surfaces.

52-072R950ml20.50



MERCER'S HULL CLEANERS

Great value in an economical product that works. Used by many commercial and government vessels. Look at the Price!

52-307R1 Litre8.95
52-308R4 Litres23.95



RAIN X ANTI-FOG

Prevents fogging of interior glass and mirrors.

52-157R207 ml9.95



RAIN X ORIGINAL

Dramatically improves wet weather driving visibility. Repels rain, sleet, and snow.

52-153R207 ml9.95
52-154R473 ml15.25



HULL CLEANER

Removes stains, scum lines, rust and marine growth. 15-20 minutes dry time. No hard rubbing required. Harmless to skin. Easy to use and it works!

52-076R32 oz29.95
52-088RGal86.95



DETAIL BRUSH

Detail Brush with Stainless Bristles. For all those hard to reach places where large brushes can't get yet need proper brushing.

52-098R7 3/4" x 7/16"6.25



SNAP AND ZIPPER LUBRICANT

Apply to boat snaps, metal and plastic zippers to protect against corrosion, reduce wear and friction, prevent binding and repel salt spray deposits. Non-toxic, non-staining. Will not wash off.

52-068R2 oz16.50



SCOURING PADS

Used extensively in fish plants. #96 medium.

16-220A6" x 9" 1.49/ea.



WATERPROOFING

This is a great product that has many uses. Prevents rotting & stops mildew. For boat covers, bimini tops, sail covers, clothing and tents. Does not change color or feel of fabric. Simply spray on application. Allows fabrics to "breathe".

52-084R22 oz33.95



J.B. WELD "WATERWELD" EPOXY PUTTY

Repair & Seal in underwater and wet conditions. Specially formulated epoxy stick. Sets in 15-25 minutes. Repair: Fiberglass, PVC Plastic, Copper, Iron, Aluminum.

52-662R#827716.95



J.B. WELD "KWIKSTEEL" EPOXY PUTTY

Repair and rebuild anything made of metal. Adheres to: Stainless Steel, Aluminum, Iron, Copper, Brass, Bronze.

Repairs: Machine Parts, Rust Damage, Leaking Pipes
52-665R#826715.50



J.B. WELD "MARINEWELD"

Formulated like our industrial-strength J-B WELD cold-weld, MARINE WELD cures as strong as steel, and is water- and weather-proof. It's impervious to saltwater, chemicals, oil, acids, and other corrosive materials, and tolerates extreme temperature fluctuations. Every boat afloat should carry MARINE WELD for quick and permanent repairs from surf board nicks to hull repairs.

52-667R#827215.50



FREEZE-FIX FIBREGLASS TAPE

A strong, permanent repair. An alternative to soldering, welding and cementing. Works on wet, dry, clean or dirty corroded pipes – even underwater! Good for water, gas, fuel and hydraulics. Water activated.

52-003M3" x108" kit.....19.95



CLEANING RAGS

General purpose rags for cleaning.
52-321H.....20 lb Bag.....P.O.R.



EPOXY PUTTY STICK

Emergency repair putty. Easy to use, just hand knead until color turns white and apply to damaged area. Product cures under water as well.

52-280R....Fiberglass,wood,metal & plastic.....30.95
52-279RAluminum Boat.....30.95



TOILET TREATMENT (320Z)

Toilet chemical for holding tanks. Non-formaldehyde, non-staining, biodegradable formula allows pump out at any dumping station. Lubricates drain valves. One ounce treats five gallons.

52-282RLemon.....27.95



3M



5200 FAST CURE ADHESIVE/SEALANT

OUR BEST SELLING 3M PRODUCT! A faster curing version of world famous 5200 below. Tack free in 1 hr. Full cure in 24 hrs. Seal is extremely strong and flexible. For above and below waterline.

- 52-251PWhite, 10 oz. Cart (295 ml) 33.50
- 52-900PWhite, 3 oz. Tube (89 ml) 23.50

3M



4200 FAST CURE ADHESIVE SEALANT

A one-part general all-purpose polyurethane that chemically reacts with moisture to deliver flexible bonds with good adhesion to wood, fiberglass, gelcoat, plastics and metals. Paintable and sandable. Forms watertight, weather-resistant seals on joints and boat hardware above or below the waterline. Good for use in places where products may have to be removed, such as windows, etc.

- 52-291PWhite, 10 oz Cart.(295 ml)33.95
- 52-901PWhite, 3 oz Tube (89 ml)20.50
- 52-452PBlack, 10 oz Cart. (295 ml)34.50

PETTIT
NEW



PETTIT EXTEX MARINE EPOXY REPAIR COMPOUND

Easy to use 1:1 mix ratio repair compound for cracks, gouges, voids and holes. High strength formula makes repairs permanent. 100% waterproof when cured. Can be used above and below the waterline. Will not sag, shrink or run. Available in 4oz and 16oz

- 54-056M4 oz.....29.95
- 54-057M16 oz.....67.95

3M



5200 MARINE ADHESIVE/SEALANT

Highest quality polyurethane sealant. For above or below waterline. Bonds to wood, fiberglass, aluminum and plastic. Tack free in 48 hrs. Cures in 5 to 7 days. Stays flexible without shrinkage.

- 52-089PWhite, 10 oz. Cart36.95
- 52-099PMahogany, 10 oz Cart36.95
- 52-453PBlack, 10 oz. Cart.....36.95

BOSTIK



920 FAST SET URETHANE MARINE SEALANT

One of the best marine sealants available. Tack free in 100 minutes. Temp. range -40F to 180F. Flexible. Good above and below waterline. Moisture cure. Bonds most boat building materials. 300 PSI tensile strength.

- 52-197PWhite, 10.3oz. Cart.16.95
- 52-198PBlack, 10.3oz. Cart.....16.95

3M



3M 4000 UV FAST CURE POLYETHER SEALANT

Paintable, non-yellowing formula won't harm ABS, Lexan or other plastics. For use on wood, fiberglass, metal and plastics. Sealant cures to form a firm, rubbery waterproof seal. Flexibility allows for the dissipation of stress caused by shock, vibration, swelling or shrinking.

- 52-440PWhite, 10 oz Cart29.50

3M



MARINE SILICONE SEALANT

Adheres to metal, fiberglass, plastic, abraded rubber and glass. Remains flexible in harsh marine environments.

- 52-450PClear, 10.3oz. Cart. (295 ml)46.50
- 52-451PWhite, 10.3oz. Cart. (295 ml)46.50
- 52-902PWhite, 3 oz Tube (89 ml)19.95
- 52-903PClear, 3 oz Tube (89 ml)19.95



CAULKING GUN

9" caulking gun. Aluminum handle. Double push plate. With needle.

- 52-174M8.95

Interlux



INTERLUX FAIRING COMPOUND

Watertite is a two part, easy to use epoxy compound for filling holes and repairing scratches in gelcoat and fiberglass above and below the waterline. It has a long easy-to-sand window and can be applied to a thickness of 3/4" without sagging. Its superior spreadability makes it an ideal glazing compound for filling small nicks and scratches.

- 54-568P500ml61.95



BILGE RAT (OIL SPILL CONTROL)

Absorbs up to 1 1/2 gallons of petroleum fluids. Works well in boat bilges. 4" Dia x 18" long.

44-786P12.55



OIL SPILL CONTROL SHEETS

Great products for cleaning small oil spills around your boat. Also works well when leaving under bearings, u-joints or any area where small leaks tend to occur. Easily disposable. 19" x 15" x 3/16" thick.

Absorbs Oil Only (White Colour)

44-787P0.59 ea

Absorbs All Liquids (Grey Colour)

44-789P1.25 ea



OIL ABSORBANT BOOM (5" X 10')

Take control of outdoor spill response with Oil-Only Booms. Poly-blend filler repels water while only absorbing oil and other hydrocarbons. Connectors link booms together to create a containment system big enough to handle almost any spill size. Provides quick, efficient cleanup to help protect the environment from contaminants; suited for short-term use.

Absorbency up to 7.5 gal. per boom

44-790P29.95



VEHICLE EMERGENCY SPILL KIT

This kit contains: 20 oil absorbant sheets. Two 3" x 4' oil absorbant socks. 1 pair of disposable gloves. 1 disposable bag.

44-784P39.95

NEW

Bebbington



VIROSAN CLEANER

A heavy-duty, ready-to-use disinfectant cleaner that is registered with Health Canada and suitable for use on hard surfaces in plenty of environments including hospitals, offices and care homes. It is likely to kill SARS-CoV-2 (the virus that causes COVID-19). Virosan is non-toxic, non-corrosive, and non-flammable.

52-300R650 ml.....8.95

52-301R4 Litre.....25.95



O'KEEFE'S WORKING HANDS HAND CREAM

O'Keeffe's Working Hands is a highly effective moisturizer for severely dry skin that frequently cracks and splits. The odourless, concentrated formula naturally hydrates the skin, adjusting the pH balance and helping to retain moisture. Creating a difference you feel within days.

52-910K.....3.4 oz17.95

NEW



GOJO SCRUBBING WIPES

Convenient, easy and complete clean up anywhere heavy-duty cleaning is required. Made of dual-textured material pre-moistened with cleaning solution, the wipes have an extra-large size towel to increase cleaning capacity. The scrubbing side removes tough soils, while the smooth side helps absorb dirt. 72 Wipes per cannister.

52-503M29.95



GOJO HAND CLEANER

Quick-acting, lotion hand cleaner with pumice scrubbers. Cleans without harsh solvents. Effective on dirt, oil and grease. Natural citrus ingredient. Orange citrus fragrance

52-501M1/2 gal.....16.95



O'KEEFE'S HEALTHY FEET CREAM

O'Keeffe's for Healthy Feet is a highly effective moisturizer for severely dry feet that frequently crack and split. The odourless, concentrated formula naturally hydrates the skin, adjusting the pH balance and helping to retain moisture. Creating a difference you feel within days.

52-913K.....3.4 oz17.95



GORILLA GLUE

Original Gorilla Glue built a name for itself with its incredible, industrial holding power and versatility. Water activated, it expands into materials to form an incredibly strong bond to virtually anything. Gorilla Glue is your solution for almost any project or repair. It's 100% waterproof, safe for indoor and outdoor use. Sand it, paint it, stain it.

- Clamp Time: 1-2 Hours •Open Time: 10-15 Minutes
- Dry Time: 80% in 1-2 Hours •Dry Color: Light Tan
- Full Cure: 24 Hours

52-888K.....	3g Minis (pk of 4)	10.95
52-889K.....	2 oz (59 ml).....	10.95
52-890K.....	4 oz (118 ml).....	15.95
52-891K.....	8 oz (236 ml).....	28.95



GORILLA WOOD GLUE

A PVA glue, offers the benefits of an easy-to use, water-based adhesive, with the holding power Gorilla is known for. The glue is incredibly water resistant and dries a natural color that offers an invisible bond line for your projects.

- Clamp Time: 20-30 Minutes •Open Time: 5-10 Minutes
- Dry Time: 80% in 1-2 Hours •Dry Color: Natural Wood Color •Full Cure: 24 Hours

52-897K.....	4 oz (118 ml).....	5.75
52-898K.....	8 oz (236 ml).....	6.95
52-899K.....	18 oz (532 ml).....	10.95



GORILLA TAPE WHITE

Triple-layer strength and outstanding versatility. It's perfect for indoor and outdoor use. Superior UV resistance and ability to grip to rough, uneven, unforgiving surfaces like wood, stone, stucco, plaster, brick and more.

52-883K	1.88 in. x 30 yds.....	20.95
---------------	------------------------	-------



GORILLA SUPER GLUE

Its high strength and quick set time make this glue the go-to for many household projects. Developed for long-lasting repairs in an instant, it dries in 10-30 seconds and is reinforced with rubber for increased impact resistance. It stands up to wear and tear unlike any other instant glue. Also has an anti-clog cap with a metal pin to ensure an airtight seal for maximum reusability.

- Clamp Time: 10-30 Seconds •Open Time: Not Repositionable •Dry Time: Light handling after 1 - 5 min
- Dry Color: Translucent •Full Cure: 24 Hours

52-894K.....	0.22 oz Tube (3 Tubes per pk.)	6.95
52-895K.....	0.71 oz	9.50



GORILLA EPOXY

Superior solvent and water resistance, Gorilla Epoxy is incredibly strong and durable for household and automotive repairs alike. The easy-to-use syringe keeps the resin and hardener separate, so it is easy to dispense and won't harden over time. The two-part, gap-filling formula easily bonds steel, aluminum, wood, ceramic, tile and most plastics. Dries in a crystal-clear finish.

- Clamp Time: 30 Minutes •Open Time: 5 Minutes •Dry Time: 24 Hours •Dry Color: Clear •Full Cure: 24 Hours

52-896K.....	0.85 oz (25 ml)	9.95
--------------	-----------------------	------



GORILLA TAPE CAMO

Mossy Oak® Break-Up® Infinity™ pattern. Ideal for applications in the field including duck blinds, tree stands, tent repairs and more! All of the same attributes that make Gorilla Tape a must-have product around the house, make Gorilla Tape Camo a "must have" product in the field. No other camo duct tape offers the pattern clarity, depth, and matte surface finish like this tape.

52-887K	1.88 in. x 9 yds.....	10.95
---------------	-----------------------	-------



GORILLA GLUE WHITE

The same serious strength you expect from Original Gorilla Glue, in a dries white, faster formula. Whether indoors or out, White Gorilla Glue is 100% waterproof, resistant to extreme heat and cold, and easily bonds foam, wood, metal, ceramic, stone and much more!

- Clamp Time: 30-60 Minutes •Open Time: 5-10 Minutes
- Dry Time: 80% in 1-2 Hours •Dry Color: Soft White •Full Cure: 24 Hours

52-892K.....	0.75 oz	8.50
52-893K	2 oz.....	10.95



GORILLA TAPE

Gorilla Tape has taken duct tape to a new level. Gorilla Tape's toughness surpasses ordinary tapes, making the list of uses virtually endless. Made with double thick adhesive, strong reinforced backing, and a tough all-weather shell, it's the biggest, strongest, toughest thing ever to happen to tape. It sticks to rough and uneven surfaces, including wood, stone, stucco and brick, that ordinary tapes can't hold.

52-881K.....	1 in. x 30 ft	5.75
52-884K	1.88 in. x 12 yds.....	10.50
52-885K	1.88 in. x 35 yds.....	19.95
52-886K	2.88 in. x 30 yds.....	29.95



GORILLA CLEAR REPAIR

No other tape offers the clarity, strength and durability of Gorilla Clear Repair! The ideal solution for almost any repair, Gorilla Clear Repair features the strength of Gorilla Tape in a weatherproof, airtight, crystal-clear tape. Easy to tear by hand. You can fix, patch, seal, hold and protect almost any surface with a crystal-clear appearance for a perfect fix every time.

52-882K	1.88 in. x 27 ft.....	14.50
---------------	-----------------------	-------



3M™ SUPER 77™ SPRAY ADHESIVE

High tack, high coverage and fast drying for permanently attaching foils, carpeting, lightweight foams, paper, cardboard, felt and cloth to painted or unpainted metals, wood and hardboard.

52-190P467g.32.95



3M 1099 ADHESIVE

Used for applying hull liner and other products.

52-188P1 Litre131.50



3M DUCT TAPE

#3939 Silver 3M duct tape.

56-027R.....2" x 60 yds16.50



3M SAFETY-WALK TAPE

Anti-slip material for medium and heavy traffic areas . Ideal for boat walkways and decks. Black.

56-013M.....2"2.29/ft.

56-014M.....4"4.59/ft.

56-015M.....6"6.79/ft.

Per Roll

56-016M.....2" x 60'113.95

56-017M.....4" x 60'204.95

56-018M.....6" x 60'306.95

ANTI-FATIGUE MATTING

Has an ergonomic surface that is waterproof, skidproof, dirt resistant and easy to clean. 3/4" Thickness. It can be swept or washed with conventional cleaning products. It is used in both industrial and commercial applications.

- It reduces fatigue caused by long hours in a standing position.
- It prevents injury and stress and can cushion a fall.
- It insulates from cold and humidity.
- It absorbs vibration from machinery and reduces noise.
- It is durable and resistant to calcium, frost and most acids.

Made from 100% recycled rubber.

Regular Edge

56-052J48" x 72" SheetP.O.R.

Interlocking Edge

56-050J46" x 69" SheetP.O.R.

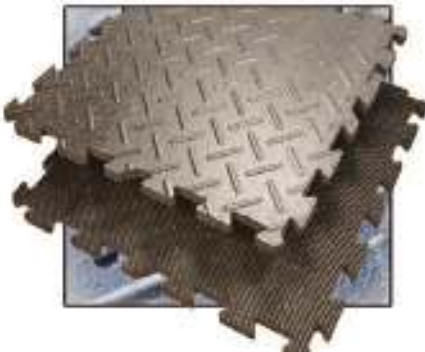

Interlocking Edge

Regular Edge



- Always Open
- Sale & Feature items
- View Catalogue
- Thousands of products
- Updated regularly
- Up to date pricing
- Mobile friendly
- Shop from anywhere at anytime

www.mercersmarine.com

Also find us on





COMET PISTOL FLARE LAUNCHER KIT

COMET 12-Gauge Flare Gun Kit for use on non-CSI inspected vessels. Kit includes Pistol, 6 Twin Star Cartridges. Each flare is ejected to a height of 61m and burns for 5.5 seconds at 10,000 candela. The COMET 12-Gauge Flare Gun Kit is Transport Canada Approved.

- 50-118PFlare Gun Kit with Hard Case.....154.95
- 50-119PFlare Gun Kit Carded, No Case.....128.95
- 50-121Preplacement twin star meteors ...13.60ea.
- 50-122PCarry Case.....32.95



FLARE STORAGE CONTAINER

Watertight and rugged, great for storing your flares or anything else that needs to be kept dry. Measures 16" high x 8" diameter.

- 50-111PCM1280.....74.95



BOATERS DRY BOXES

Great for carrying flares, tools, First Aid supplies, etc. Constructed of tough, water and rust resistant plastic. This box features a sealed, lockable cover and comes with convenient carry handle. Stackable. Supplied in international orange color. A must for every boater.

- Small Dry Box**
- 46-512KOD:15"L x 7 3/4"W x 6 1/2"H..... 43.95
- Large Dry Box**
- 46-513K OD:15"L x 7 3/4"W x 11 1/2"H 58.95
- Field/Utility Box**
- (Same basic description)
- 46-713KOD:15"L x 8 1/2"W x 9 1/2"H..... 64.95



HANDHELD FLARE - TYPE C

Easy and safe handling in a compact size. Comfortable grip, telescopic design with pull-wire igniter. For use in day or night. Releases a red flame for 60 seconds. SOLAS approved.

- 50-008Peach21.50



PARACHUTE SIGNAL ROCKET - TYPE A

Easy and safe handling in a compact size. Secured handling due to non-slip grip, low recoil. For use in day or night. Releases one red star of 40 seconds burning time and 30,000 candela. SOLAS approved.

- 50-009Peach53.95



HYDROSTATIC RELEASE FOR LIFERAFT

- 50-100K104.95



SMOKE SIGNAL

Signal for position marking during rescue operations or as an emergency signal for daylight use. Dense orange smoke that will last for 4 minutes. Safe on oil or fuel contaminated water. SOLAS approved.

- 50-052P58.95



SOLAS REFLECTIVE TAPE

A quality "Peel and stick" reflective tape which meets the SOLAS requirements. U.S. Coast Guard and IMO certified.

- 56-045R2" Wide2.59/Ft.
- 56-046R150 Ft. Roll310.00



STORAGE CASES/SURVIVOR BOXES

Highly durable Polypropylene construction. Lockable (lock not included). Rubber gasket sealed lid for water resistance. Stackable for easy storage.

- 20-1000M6.75" x 8.75" x 4.5"13.95
- 20-1001M10" x 7" x 3.25"17.25
- 20-1002M11.5" x 5.25" x 7.25"21.25
- 20-1003M13.75" x 7.5" x 8.75"33.25
- 20-1004M16" x 9" x 10.25"43.25
- 20-1005M18" x 19.25" x 8.25"65.50



SAFETY LADDER

Bag pulls open and ladder unfolds instantly, helping a person get back onboard. Bag is canvas with one handle to attach the bag alongside the boat and another for the person fallen overboard to grab.

- 50-040P4 Step Ladder139.95
- 50-041P5 Step Ladder164.95



COMET L-170 LIFE BUOY LIGHT

This extremely compact light uses a 5-year lithium battery for "fit & forget" application. It is automatically activated after release. The unit is disposable after the 5 year life span.

50-066P57.50



WATER ACTIVATED LED STROBE LIGHT

Activates immediately in water. Waterproof octagonal design far exceeds USCG requirements for light output and duration. Shatterproof, fungus-resistant globe and body. Automatic and manual mode. Use with lithium or alkaline batteries (Not included)

50-092P64.90



LIFEBUOYS

Polyethylene outer shell with closed circular foam core. Transport Canada and S.O.L.A.S. approvals as indicated. (See below for life ring safety rope)

- 30" Dia. - Commercial Vessels. Orange
- 50-000PRetro - Reflective Tape109.00
- 24" Dia. - Pleasure Boats up to 12 m. Orange
- 50-001P108.00
- 24" Dia. - Pleasure Boats up to 12 m. White
- 50-059P108.00



FOX 40 RESCUE THROW BAGS

The Fox 40® Rescue Throw Bags are highly durable drawstring bags. Contain premium polypropylene woven floating rope with 900 lb (408 kg) breaking strength. Throwing and repacking instructions are printed on the back of both bags.

- 50-243P50 ft25.95
- 50-244P90 ft35.95



NORTH 49 HEAVING LINE

Hi-visibility throw bag with 50 ft or 60 ft of floating line. Complies with Canadian Coast Guard equipment requirements.

- 50-016P50 ft21.25
- 50-017P60 ft27.25



LIFEBUOY SAFETY ROPE

Floating, braided 5/16" polypropylene rope, yellow with red tracer. Used on lifebuoys. Commercial regulations require 27 meters (89 ft.) per lifebuoy.

66-534R0.35 per ft.

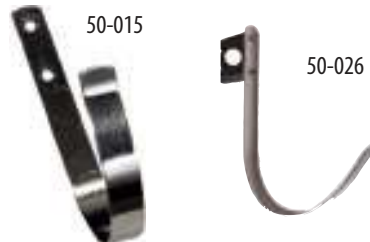

STAINLESS STEEL LIFEBUOY HOLDERS

Fits all Life Buoys above. For proper installation 3 holders are required.

- 50-015R5.95 ea.
- 50-026RFits 7/8" and 1" Railing7.95 ea.



100' HEAVING LINE & BAG

100 feet of line with plastic loop handle on end to ensure a secure grip. Bag come with a float and is weighted to allow for a more accurate and further throw.

50-018P100 ft49.95



PLASTIC OARS

45" in length.

46-1030R17.95 ea.



WATER RESCUE THROW RING

50 ft braided rope. Lightweight and floats; easy to use. Textured grip. Brightly coloured for day or night visibility. Quick-release plug prevents rope from deploying inadvertently. Superior alternative to fabric throw bag. Clearly visible, easy to grasp and throw. 13 1/4" Diameter.

50-242R41.95



OCEAN "RESCUE ME" PERSONAL LOCATOR BEACON

Wherever you are, at sea, on land, the rescueME PLB1 provides the reassurance that global emergency services can be alerted by the press of a button.

The rescueME PLB1 can be operated with a single hand in even the most challenging situations. A simple spring loaded flap covers the activation button preventing inadvertent use.

rescueME PLB1 works with the only officially recognised worldwide dedicated search and rescue satellite network (operated by Cospas Sarsat). As this is funded by governments there are NO CHARGES to use this service.

When activated the rescueME PLB1 transmits your position and your ID to a Rescue Coordination Center via satellite link. Rescue services nearest to you are promptly notified of your emergency and regularly advised of your current location to assist prompt rescue.

The rescueME PLB1 is provided with a flotation pouch to fit the PLB into to enable it to float. Please note that the PLB will not float in an operating position in the pouch. Please ensure the PLB is firmly attached to the pouch with the provided lanyard, using suitable self locking knots.

- 30% smaller (typ) by volume
- Easily fits to lifejacket*
- Retractable Antenna
- 7 Year Battery Life
- 7 year warranty
- 24+ hour operational life
- High brightness strobe light >1candela
- 66 channel GPS receiver
- Unique mounting clip
- Operates on the global Cospas Sarsat rescue system
- Free to use, no subscription charges
- Supplied with free flotation pouch

* Always refer to the manufacturer for specific instructions before installing this product directly to your life jacket.

50-248A P.O.R.



OCEAN SIGNAL EPIRB

The rescueME EPIRB1 provides peace of mind with an impressive 10 year battery life. The world's most compact EPIRB can always be on hand, as its small size allows it to be easily retained within its quick release bracket or placed in an emergency grab-bag or life raft. A simple protective tab over the operating keys prevents inadvertent activation, yet allows for easy operation when required.

The retractable antenna provides maximum protection and a reduced outline for stowage. When required the antenna is easily deployed with a gentle pull.

Incorporates a state of the art 50 channel GPS receiver for fast and accurate position acquisition. Extreme battery life even at low temperatures, in excess of 96 hours operation. Intuitive operating controls protected from accidental activation. Fitted with a 121.5 MHZ homing beacon and a high brightness LED strobe light for fast on-scene location.

50-246A P.O.R.

50-247JHydrostatic Release for Epirb.....P.O.R.



CYLINDRICAL RADAR REFLECTORS

Model 25587

46-1602KBlack.....46.95
Ratchet mount. 2" x 22"L.

Model 29496

46-1603KBlack.....94.95
Ratchet mount. 4" x 22"L.

Model M-2

Adjustable ratchet base mount.
2" dia. x 23"L.

66-576KBlack.....98.95

Model S-2

Eye hooks on both ends for rigging mount.

66-575KBlack.....84.95

Model M-3

Fixed base mount. 4" dia. x 15"L.

66-574KBlack.....149.95

Boating Safety



MARINE EQUIPMENT



BOAT ESSENTIALS KIT

Basic waterproof kit designed to help bring your Boat, Canoe or Kayak up to regulations. Container also acts as bailer bucket.

Compact Kit includes: waterproof Fox 40 Marine Incandescent Flashlight, Fox 40 Pearl Pealess Safety Whistle, 50 ft (15 m) braided Rope & Float.
50-230R.....15.95



CLASSIC BOAT SAFETY KIT

Housed in an ergonomic and aesthetically pleasing bailer, the kit includes all minimum safety requirements for your personal watercraft - no need to buy everything separately! Innovative design makes bailer easy to grab in an emergency. Storage-friendly!

Kit includes: waterproof Fox 40 Marine LED Flashlight, Fox 40 Pealess Safety Whistle, 50 ft (15 m) woven polypropylene Fox 40 Marine Rope & Float, Bailer capped with mirrored SOS lid, 2 AA Duracell batteries.
50-231R.....29.95



DELUXE BOATING KIT

Kit fits in black snap-lid case. Case dimensions: 15.5" wide x 7.0" high x 9.5" deep.

Deluxe Kit includes: Waterproof Fox 40 Marine Incandescent Flashlight, Fox 40 Pearl Pealess Safety Whistle, 50 ft (15 m) Braided Rope & Float, Fox 40 2.0 lb 1A5BC Fire Extinguisher, 1.5 Kg Anchor, 50 ft (15 m) Anchor Line with Carabiner Clip.
50-232R94.95



WATER SAFETY THROW

Aerodynamic shell sails through windy conditions while traditional fabric bags tend to get caught up in the wind. The integrated handle is clearly visible and easy to grasp. A quick-release plug prevents the rope from deploying inadvertently. The 50 ft (15 m) premium polypropylene braided floating rope has 900 lb breaking strength. Unique knit rope provides a degree of stretch while also providing ultimate strength.

50-233R.....29.95



MARINE "LED" FLASHLIGHT

Waterproof floating flashlight with three LED blubs. Shock-resistant casing and non-slip grip. Bright color. Bulbs project 8-12 lumens beam strength with 50,000 hours lifetime LED. **Two AA batteries included.**

50-234R.....11.75



CLASSIC SAFETY WHISTLE WITH LANYARD

The harder you blow, the louder the sound! Reliable, flawless consistent and penetrating sound. It will be heard above ambient noise, the roar of engines, breaking waves and thundering gale-force winds. The chambers are designed to self-clear when submerged in water. There are no moving parts to freeze, jam or deteriorate.

50-237R.....8.50



FLOATING NECK LANYARD AND FOX 40 MICRO WHISTLE

Our extremely functional and comfortable Floating Neck Lanyard uses flexible tubing to provide float protection. Blue Fox 40 Marine Safety imprinted lanyard includes 2 black crimp-style adjustable sliders. Includes Fox 40 Micro Pealess Whistle.

50-236R.....14.95



GUARDIAN LED LIGHT AND FOX 40 MICRO WHISTLE

Dual-function Guardian LED Light Features: Versatile, lightweight and extremely impact-resistant. Omnidirectional light is visible up to 3 miles. Flashing mode provides 250 hrs operational light. Up to 100,000 hrs lifetime bulb. Submergeable up to 330'. Heat (+50°) and cold (-40°) tolerant

50-235R.....18.95



LIFEJACKET WHISTLE

S.O.L.A.S. approved. Plastic construction.
50-007R.....1.99

SONIK BLAST CMG MARINE WHISTLE

A must for emergency protection, onsite disaster management and search & rescue! Flawless patented pealess whistle emits distinct louder pitch without a lot of effort. Cushioned Mouth Grip provides additional comfort and is perfect for reliably holding the whistle in the mouth in wet conditions.

50-238R.....8.95



FIRE EXTINGUISHERS

Our fire extinguishers are dry chemical and approved to fight A, B, C type fires. All are rechargeable and have charge indicators.

2 1/2 and 5 lb. models come with bulkhead mount bracket.

50-027P2 1/2 lbs.....67.95

50-028P5 lbs.....88.95

The 10 lb model is supplied with wall hook. Bulkhead bracket is optional.

50-030P10 lbs137.95

50-031KBulkhead Bracket (10 lb only)54.95



FIRE BUCKET

Metal fire bucket with round bottom.

50-019R56.95



FIRE AXE

Fiberglass handled fire axe with spike.

50-011RApproved Fire Axe..... 63.95

STAINLESS STEEL FIRE AXE BRACKET

50-012R 29.90



FIRE HOSES AND NOZZLES

Extra strength and flexibility in a proper industrial grade "Layflat" style hose for fire fighting or washdown.

Polyester jacket with synthetic rubber liner. Complete with "Pyrofile" fittings.

Polyester Fire Hoses

38-177M1 1/2" x 25ft109.95

38-178M1 1/2" x 50ft149.95

Fire Nozzles

38-175M3/4" Nozzle(Plastic).....25.95

38-176M1" Nozzle(Plastic)25.95

38-179M1 1/2" Nozzle(Plastic)23.95

38-318M2" Nozzle(Plastic)125.95



PORTABLE HORN

Ideal for Boating, Sports, Outdoors, Industrial.

Recommended for boats up to 12 m (39.4 ft).

Non-Flammable.

50-032RComplete19.95

50-033RRepl. refill11.95



MTI CO2 DETECTOR

Model FX4

Most Reliable. Boats DC electrical system or marine grade batteries supply power to the alarm. No missing or dead batteries to replace. Proven Sensing Technology. Prevents nuisance alarms which could lead to confusion and disconnected detectors. Advanced Technology.

Alarm Mute button with advanced technology that silences alarm while boat is ventilated. Rapid recovery sensor resets when silenced or reactivates alarm if dangerous levels of CO remain. Loud. 85 dB alarm alerts you to CO danger. Case Size: 2.5"W x 3.5"H x 1.25"D

50-058P84.95



FUME/FIRE/BILGE DETECTOR

Model MGD-1XL

Fumes detected: Gasoline, hydrogen from batteries, propane, alcohol, acetone, CNG and other explosive vapors. This unit will alert you to the presence of a propane or gasoline leak. Fire alarm triggers with a 180° thermal switch. Water sensor triggers during high bilge water conditions. 12V. 3 1/4"L x 2 3/4"W x 3/4"H.

50-087P136.95



FUME/FIRE/FLOOD DETECTOR

Model MGD-10XL

Sight and Sound Alarm Indicator. Dual signaling sounds an alarm / activates warning light.

Smart Fume Sensor. Detects the build up of explosive gases such as gas and propane.

Thermal Sensor. Monitors for high heat and heat from fire.

Water Sensor. Monitors bilge for high water.

On/Off/Test. For one touch analysis of detector performance. Marine Proven. Exclusively designed for the harsh marine environment. 12V. 3 1/4"L x 2 3/4"W x 3/4"H.

50-089P174.95



MTI SMOKE DETECTOR

Model SA-866

Photoelectric sensor for slow smouldering fire. Long life lithium battery (Up to 10 Years). Miniature size. Hush feature. Power & alarm test button. Low battery warning. Loud 85db alarm signal. Supplied with wall plugs & screws. Pre-warning fault signal.

50-140P32.95



FIRST AID KITS

- Type 1 Personal
50-400P.....Hard Case16.95
- Type 2 Small (2-25 People)
50-401P.....Hard Case30.95
- Type 2 Medium (26-50 People)
50-402P.....Hard Case50.95
- Type 2 Large (51-100 People)
50-403P.....Hard Case86.95
- Type 3 Small (2-25 People)
50-404P.....Hard Case62.95
- Type 3 Medium (26-50 People)
50-405P.....Soft Bag76.95
- Type 3 Large (51-100 People)
50-406P.....Soft Bag114.95

SELECTION OF FIRST AID KIT(S) FOR A WORKPLACE ENVIRONMENT				
WORKPLACE FIRST AID KIT CLASSIFICATION	1 EMPLOYEE OR WORK IN ISOLATION	2 - 25 WORKERS PER SHIFT	26 - 50 WORKERS PER SHIFT	51 - 100 WORKERS PER SHIFT
TYPE 1 PERSONAL (See Clause 5.3)	1	NA	NA	NA
TYPE 2 BASIC (See Clause 5.4)		1 SMALL	2 SMALL; OR 1 MEDIUM	4 SMALL; OR 2 MEDIUM; OR 2 SMALL AND 1 MEDIUM; OR 1 LARGE
TYPE 3 INTERMEDIATE (See Clause 5.5)		1 SMALL	2 SMALL; OR 1 MEDIUM	4 SMALL; OR 2 MEDIUM; OR 2 SMALL AND 1 MEDIUM; OR 1 LARGE

TO ORDER DETERMINE TYPE / FORMAT REQUIRED - SELECT FROM PRODUCT LISTING	
<p>CLAUSES</p> <ul style="list-style-type: none"> ◊ 5.3 Workplace First Aid Kit Requirements Type 1 : Personal First Aid Kits Suitable for workers who work in isolation or those who do not otherwise have access to a workplace First Aid Kit. ◊ 5.4 Workplace First Aid Kit Requirements Type 2 : Basic First Aid Kits Suitable for most workplaces with low risk work environment. ◊ 5.5 Workplace First Aid Kit Requirement Type 3 : Intermediate First Aid Kits Suitable for most workplaces with moderate or high risk work environment. 	<p>RISK LEVELS</p> <ul style="list-style-type: none"> ◊ Low Risk Workplaces A workplace in which activities with a low likelihood of the occurrence and severity of harm predominate. ◊ Moderate Risk Workplace A workplace in which activities that are neither low nor high risk predominate. ◊ High Risk Workplaces A workplace in which activities with a high likelihood of the occurrence and severity of harm predominate.

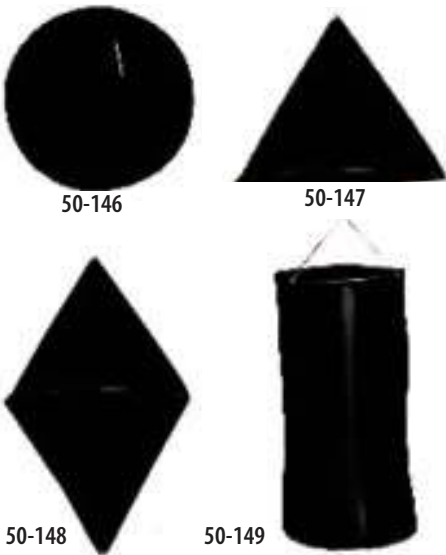

DAY SHAPES

All units manufactured from heavy-duty vinyl coated nylon fabric with stainless steel or galvanized framing. Fully collapsible when stored. Simplicity of design offers rapid and rigid display when required.

- 50-146P.....Black Ball 24" Dia124.95
- 50-147P.....Cone Shape 24" x 24"124.95
- 50-148P.....Diamond Shape 24" x 48"124.95
- 50-149P.....Cylinder Shape 24" x 48"124.95



PERKO

PERKO MOUTH OPERATED FOG HORN

50-036R.....White, Aluminum 12 1/2" O.L.....41.95



MOUTH OPERATED FOG HORN

50-037R.....Stainless Steel 7 1/2" O.L.....34.95



SHIP'S BRASS BELL

Stamp brass construction. 8" diameter supplied with wall bracket. Removable.
60-012M.....195.00



SAFETY RADAR REFLECTOR

Made of stamped aluminum. 11.8" x 11.8" x 16.3"
46-1596R.....26.95



ALUMINUM RADAR REFLECTOR

POLE MOUNT TYPE
18" x 18". Used extensively by fishers on staff buoys.
66-231K.....23.50



MUSTANG SENTINEL SERIES BOAT CREW DRY SUIT MSD636

The Sentinel series boat crew dry suits are waterproof breathable constant wear boat crew dry suits designed for law enforcement and search and rescue (SAR) small boat operations. Constructed with military grade GORE-TEX® BD6.5 waterproof breathable fabric, these dry suits are ideal for crew members who don't intend to enter the water but require hypothermia protection in case of accidental immersion. Our Sentinel dry suits are in use by US Coast Guard and validated by NAVAIR, SAR Model Manager Office, Naval Special Warfare and water rescue professionals.

- 10-239KXS2759.00
- 10-240KSm2759.00
- 10-241KMed2759.00
- 10-242KLg 12759.00
- 10-243KLg 22759.00
- 10-244KXL2759.00
- 10-245K2X2759.00
- 10-246K3X2759.00

MUSTANG SENTINEL SERIES DRY SUIT LINER MSL600GS

Designed with a combination Polartec classic 200 fleece and Polartec Power Stretch fleece, this dry suit liner provides extra insulation protection when in cold water and also helps reduce the thermal burden out of the water. The wicking fabric and thread move excess moisture away from the body to evaporate and diffuse through the outer layers of the dry suit.

- 10-194KXS360.95
- 10-195KSm360.95
- 10-196KMed360.95
- 10-197KLg 1360.95
- 10-198KLg 2360.95
- 10-199KXL360.95
- 10-200K2X360.95
- 10-201K3X360.95

MUSTANG HUDSON DRY SUIT MSD200

Waterproof. Breathable. Super Durable. Adjustable neck seal, for quick one-handed watertight closure. Waterproof YKK AQUASEAL zipper doubles as entry and relief zipper. Easy wear internal suspenders balance suit weight for maximum fit and comfort. Water-resistant zippered pockets on sleeve and thigh. Trimmable neoprene wrist cuffs for custom fit. Wrist overcuffs protect seals, and easily peel back for sleeve adjustment. Super lightweight molded knee pads stay put with knee adjustment tabs. Reinforced sock soles can handle extra abuse. External hanging loop, for drying.

- 10-203KXS1599.95
- 10-204KSm1599.95
- 10-205KMed1599.95
- 10-206KLg1599.95
- 10-207KXL1599.95
- 10-208K2X1599.95
- 10-209K3X1599.95

Items in **RED** are stocked items. Other sizes are available by Special Order. Please allow 6 to 8 weeks for delivery. For more detailed information on available sizing not shown on this sizing chart, visit our website at www.mercersmarine.com

XS	S	M	L	Lg	XL	XXL	3XL
Chest							
35-38"	37-40"	39-42"	41-44"	43-46"	45-48"	49-52"	53-56"
89-97cm	94-102cm	99-107cm	104-112cm	109-117cm	114-122cm	125-132cm	135-143cm
Waist							
29-32"	31-34"	34-37"	35-38"	37-40"	41-44"	46-49"	51-54"
74-81cm	79-86cm	86-94cm	89-97cm	94-102cm	104-112cm	117-125cm	130-137cm
Hips							
37-40"	38-41"	39-42"	40-43"	41-44"	43-46"	47-50"	53-56"
94-102cm	97-104cm	99-107cm	102-109cm	104-112cm	108-117cm	119-127cm	135-143cm
Sleeve							
29-31"	31-33"	33-35"	34-36"	35-37"	36-38"	37-39"	38-40"
74-79cm	79-84cm	84-89cm	89-92cm	89-94cm	91-97cm	94-99cm	97-102cm
Inseam							
29-30"	30-32"	32-34"	33-35"	34-36"	34-36"	34-38"	34-38"
71-76cm	76-81cm	81-86cm	84-89cm	86-91cm	86-91cm	88-93cm	86-91cm
Torso Hoop							
59-62"	62-65"	65-68"	67-70"	69-72"	71-74"	76-79"	78-81"
150-158cm	158-165cm	165-173cm	170-178cm	175-183cm	180-188cm	193-201cm	198-206cm





SEAECO IMMERSION SUIT

6 hour thermal protection. Spacious suit, separate gloves, long high quality zip. Durable, heat proof, anti slip rubber soles. Tightening straps below the knees for better fitting. Removable gloves attached with elastics. STD size fits 95% of the population. Approved for use without a lifejacket. Buoyancy pillow in back ensures correct floating position and freeboard. Immersion suit for the merchant fleet. Flame retardant 5 mm neoprene. Emergency light. With buddy line and floating hook. Lifting strap with stainless steel D-ring and carabine hook. Easy donned, waterproof PU-Zip. Approved reflective patches. Fixed hood. Watertight cuffs. Gloves attached by elastic bands. Velcro tighteners in legs. Rubber soles for optimal grip on slippery surface. May be vacuum packed for extended service intervals (maximum 5 years).

- 10-028A.....Sm.....P.O.R.
- 10-029A.....Universal.....P.O.R.
- 10-030A.....Jumbo.....P.O.R.

Sizes	Height	Weight
Adult Small	4'8" to 5'6"	N/A
Universal	4'9" to 6'5"	N/A
Jumbo	5'9" to 6'9"	N/A



NEOPRENE COLD WATER IMMERSION SUIT WITH HARNESS

Designed for use in commercial operations, the new Immersion Suit from Mustang Survival is the ideal ship abandonment suit for workboats, transport vessels, drilling rigs, supply ships, steamships and commercial fishermen. Also suitable for the sailing community. Easy to don in stormy conditions. Five-fingered insulated gloves for warmth and dexterity. Water-tight face seal. Includes buddy line. Includes lifting harness. Ankle adjustments for a better fit. 5mm fire retardant neoprene provides flotation and hypothermia protection. Triple-sealed seam construction. Non-slip, durable soles.

- 10-279A.....Sm.....P.O.R.
- 10-281A.....Universal.....P.O.R.
- 10-283A.....Jumbo.....P.O.R.

Sizes	Height	Weight
Adult Small	Max. 5' 6"	110 to 200 lbs
Universal	Max. 6'3"	110 to 330 lbs.
Jumbo	Max. 6'3"	225 to 375 lbs.



IC9001-03

ICE COMMANDER RESCUE SUIT

This modular suit is completely waterproof with a water tight hood, integrated gloves, and attached boots. The flotation and insulation performance of a zip-in buoyancy liner allows users to immerse themselves for long periods of time in icy cold water and maintain mental and physical capabilities. Updated liner with zipper and velcro attachments allow easier removal for cleaning and repair. Each Ice Commander has an integrated chest harness for attachment to tether lines, ice awl pockets for storage, rubber gloves, reinforced knees and non-slip rubber soles on the attached boots. As well, each suit is 45% lighter than other rescue suits as it is made in a high visibility welded nylon shell.

- 10-271A.....Universal.....P.O.R.
- 10-263A.....Zipper Lubricant.....P.O.R.



FITZWRIGHT AUTO LIFE JACKET LIGHT

Automatic, low-profile light is a single compact flashing unit, the light activates automatically when immersed in water and will remain lit once water activated to allow for rescue. The light can be turned off manually if required by pressing the switch, our new Alkaline range meets all the testing requirements of SOLAS, Transport Canada and the Marine Equipment Directive by using alkaline technology. This new range will last for 60 hours, way in excess of the required 8 hours.

- 50-077M.....23.50



SNAP AND ZIPPER LUBRICANT

Apply to boat snaps, metal and plastic zippers to protect against corrosion, reduce wear and friction, prevent binding and repel salt spray deposits. Non-toxic, non-staining. Will not wash off.

- 52-068R.....2 oz.....16.50



MUSTANG SOLAS LIFE JACKET

Transport Canada SOLAS. US Coast Guard Type I Lifejacket.

US Coast Guard SOLAS. Marine Equipment Directive SOLAS. Inspected and tested to SOLAS in accordance with U.S. Coast Guard regulations, Transport Canada regulations, and M.E.D. regulations. Approved for use on all vessels. Adult model weight 90 lbs (41kg) and over.

- 10-037K.....Adult Model MV8040169.95
- 10-038K.....Youth Model MV8035154.95



INDUSTRIAL MESH VEST

Model MV1255T1

The MV1255 T1 Industrial Mesh Vest offers maximum visibility, mobility, cooling and comfort with features such as large arm holes, mesh shoulders, and SOLAS reflective tape across the front and back of the vest.

Transport Canada Approved.

- 10-736K.....Sm/Med105.50
- 10-737K.....Lg/XL105.50
- 10-738K.....2X/3X105.50



INDUSTRIAL FLOTATION VEST

Model MV3196T2

The Classic Industrial Flotation Vest with SOLAS Reflective Tape is a classic PFD for industrial applications. It offers large arm holes for mobility and SOLAS reflective tape on the shoulders for visibility. A good option for the commercial fishing, commercial transportation, industrial marine, special operations and security sector. **Approval: Harmonized Level 70 - USA and Canada** (Meets minimum buoyancy of 15.7 LBS). Adjustable side straps. Reflective tape on shoulders. Large armholes.

- 10-117K.....Sm87.95
- 10-118K.....Med87.95
- 10-119K.....Lg87.95
- 10-120K.....XL87.95
- 10-121K.....2XL87.95
- 10-122K.....3XL to 7XL87.95



FITZWRIGHT KEYHOLE LIFEJACKET

Designed for Adult persons over 40kg. This basic block foam design makes storage easy and familiar to all who wear it. Also increases comfort around the neck during wear. Whistle Included. Lanyard Included. •Attachment point for approved lifejacket light. **Approval: Transport Canada/SOLAS .** Model FW-L0147C2

- 10-008K.....One Size86.00



NEW



SAR VEST

Model MV5606

The MV5606 SAR Vest has been designed and tested to hold up to the most rigorous activities. The design is helmet-friendly and the 3-belt adjustment system creates a secure fit. **Approval: Harmonized Level 70 - USA and Canada** (Meets minimum buoyancy of 15.7 LBS). Two large front cargo pockets with easy to use pull tabs for extra storage. SOLAS reflective tape for high visibility. Large cutaway armholes for maximum range of motion. 3-Belt system for a custom fit. Fast-tab radio clip

- 10-047K.....Sm182.95
- 10-048K.....Med182.95
- 10-049K.....Lg182.95
- 10-050K.....XL182.95
- 10-051K.....2XL182.95
- 10-052K.....3XL182.95



FITZWRIGHT SAR MESH VEST

Model FW-PFD1510

Flexible foam and durable 200 denier nylon construction. Soft collar for comfort. Multiple cargo pockets. Two D-rings for small attachments. Three 1.5" encircling belts, chest strap and heavy-duty zipper closure. 62 sq. inches of retro-reflective material. **Approval: Transport Canada/CCG**

- 10-060K.....Sm129.00
- 10-061K.....Med129.00
- 10-062K.....Lg129.00
- 10-063K.....XL129.00
- 10-064K.....2XL129.00
- 10-065K.....3XL129.00



MUSTANG UNIVERSAL FIT PFD

Model MV3005

This universal-fit PFD provides incredible versatility for both recreational and industrial boaters alike. The perfect PFD to have onboard for drop-in guests or a rotating work crew.

Features 3-adjustment belts and open sides for a flexible fit. Fits chest sizes up to 52".

TC/CCG/CAN/CGSB 65.11-M88 Approval

10-172K.....One Size49.95



NEW



MUSTANG LIVERY VEST

Model MV7010

The large arm holes offer a wide range of movement. A contrasting middle strap makes it easier to buckle correctly. The three-clip front entry can be adjusted to open for added ventilation. Soft 200D liner and flexible EPE/PE foam make the Livery Sport a comfortable classic. **Approval: Harmonized Level 70**

Blue

10-315KXS/Sm.....84.95
 10-316KMed/Lg.....84.95
 10-317KXL/2X.....84.95

Yellow

10-318KXS/Sm.....84.95
 10-319KMed/Lg.....84.95
 10-320K.....XL/2X84.95



MUSTANG SPORT VEST PFD

Model MV1273

An easy wearing water sport vest made with soft PVC foam and high quality nylon to provide the ultimate fit. Three big buckles keep you strapped in for all the day's activities. Airsoft™ flotation foam front for extra comfort around collar. Large armholes for good mobility.

APPROVAL: TC Marine - CAN/CGSB 65.11 - Adult PFD

10-088K.....Sm79.95
 10-089K.....Med79.95
 10-090K.....Lg79.95
 10-091K.....XL79.95
 10-092K.....2X79.95
 10-093K.....3X79.95



Mens

HORSEPOWER NEOPRENE PFD

Made with high-grade neoprene, the HORSEPOWER Neoprene PFD is designed for serious days on the water. With tone-on-tone tribal seahorse artwork and one of the most flexible fits you'll find on the market, this PFD is ready for all the horsepower you can handle. High-grade neoprene for soft, comfortable fit. Triple-secured front closure. Two waist belts for snug fit. Split tail reduces ride-up. TC/CCG/CAN/CGSB 65.11-M88 Approval.

Mens Model MV1283

10-159KXS.....109.95
 10-160KSm.....109.95
 10-161KMed.....109.95
 10-162KLg.....109.95
 10-163KXL.....109.95
 10-164K2X.....109.95
 10-165K3X.....109.95



Womens

Womens Model MV1285

10-173KXS.....109.95
 10-174KSm.....109.95
 10-175KMed.....109.95
 10-176KLg.....109.95
 10-177K.....XL.....109.95





MUSTANG SOLARIS FOAM VEST

Model MV8070

This classic high-back front entry foam vest is designed to clear most kayak seatbacks. The mesh panels are incredibly breathable, and fleece-lined pockets warm you up during rest breaks. Six points of adjustment, including padded neoprene shoulders, allow you to customize your fit. Expanded mesh cargo pockets hold your essentials and keep them accessible. Safety features include a tethered signal whistle and reflective trim on the front, back, and shoulders. **Approval: Harmonized Level 70**

Red/Black		Blue/Black	
10-300K	XS/Sm	10-303K	XS/Sm
			114.95
10-301K	Med/Lg	10-304K	Med/Lg
			114.95
10-302K	XL/2X	10-305K	XL/2X
			114.95



MUSTANG TOPWATER FOAM FISHING VEST

Model MV4112

Secure buckles and padded adjustable shoulders ensure the safety and comfort of all users. Expanding Cargo pocket, elastic straps, and a D-ring tether hold your tackle and tools, while the drop-down fishing bridge and rod holder make the most out of your limited space. **Approval: Harmonized Level 70**

10-309K	One Size	169.95
---------	----------	--------



MUSTANG APF VEST

Model MV4111

The open-sided design allows for outstanding mobility and breathability. Padded neoprene shoulders are adjustable, and strap ends tuck neatly out of the way. Two side storage pockets hold your essentials and the front and shoulders of the durable 300D polyester shell feature reflective trim. **Approval: Harmonized Level 70**

Red/Black		Black	
10-311K	One Size	10-312 K	One Size
			109.95



MUSTANG DOGVEST

Model MV5020

This PFD is for your best friend. The cape-style design has four adjustment points to ensure a secure fit on every dog. Constructed to support the pup's natural swim angle and provide maximum mobility, most of the buoyancy is under their neck and chest. USCG-approved fabrics, including durable Cordura on the belly and neck panels, make this an ideal choice for keeping your pet safe and comfortable on the water. 3D mesh on the back keeps things breathable and cool, and reflective panels enhance visibility in low light conditions. A reinforced carry-handle and leash attachment point makes the Underdog an excellent flotation device for the four-legged.

10-324K	2-12 lbs	89.95
10-325K	12-24 lbs	89.95
10-326K	24-60 lbs	89.95
10-327K	60-90 lbs	89.95
10-328K	90-120 lbs	89.95



MUSTANG REFLEX VEST

Model MV7020

A 200D polyester shell provides dependable durability and two expanding cargo pockets and daisy chain attachments secure your gear. A deep V neck and large shoulder openings increase mobility. Evenly distributed thin foam panels provide consistent floatation around the body. A tethered signal whistle and reflective trim on the front, back, and shoulders offer added safety. **Approval: Harmonized Level 70**

Red		Blue	
10-329K	XS/Sm	10-332K	XS/Sm
			119.95
10-330K	Med/Lg	10-333K	Med/Lg
			119.95
10-331K	XL/2X	10-334K	XL/2X
			119.95

Prices are subject to change. Check our website for up to date prices. www.mercersmarine.com



KIDS



MUSTANG LIL'LEGENDS CHILD VEST

MV3555 (Fits children weighing between 33 to 55 lbs)

Designed with your child's ultimate comfort in mind, it offers all the bells and whistles to keep your wee one safe, including head pillow, crotch strap, and grab handle. Ultra soft. Stain resistant. Ventilated mesh back. Wicking liner. Sturdy grab handle. Crotch Strap. 3 piece head pillow. Fully adjustable. **Approval: Harmonized Level 70**

MV3555-268 - Blue	MV3555-277 - RED
10-078K.....(33 to 55 lbs)99.95	10-079K.....(33 to 55 lbs)99.95



KIDS

CLASSIC CHILD'S PFD

The Classic Infant PFD features an adjustable waistbelt and legstrap for a secure fit, a head cushion to cradle the head in the water and a safety grab strap for ease of rescue. Made of high-tenacity nylon. **Transport Canada Approved.**

10-126K.....MV1203 (20 to 30 lbs).....	64.95
10-127K.....MV1205 (30 to 60 lbs).....	69.95
10-128K.....MV1207 (60 to 90 lbs).....	69.95



KIDS



MUSTANG LIL'LEGENDS YOUTH VEST

MV3560 (Fits youth weighing between 55 to 88 lbs)

Ultra soft. Fits youth weighing between 55-88 lbs (25-40 kg). Stain resistant. Ventilated mesh back. Wicking liner. Sturdy grab handle. 3 piece head pillow. Fully adjustable. **Approval: Harmonized Level 70**

MV3560-268 - Blue	MV3560-277 - RED
10-080K.....(55 to 88 lbs)99.95	10-081K.....(55 to 88 lbs)99.95



MUSTANG REV YOUNG ADULT VEST

Model MV3600

(Fits youth weighing between 88 to 110 lbs)

A form-fitting chassis specifically for young adults, this vest bridges the gap from children's to Adult PFDs. Segmented foam moves with the body making it comfortable to wear. Specially designed interior foam panels form-fit the body to fit better than a size small adult vest. MOLLE inspired accessory panel for custom attachment of gear. Ventilated mesh back for breathability. Wicking liner allows for quick drying. Sturdy grab handle. Fully adjustable. **Approval: Harmonized Level 70**

10-082K.....(88 to 110 lbs)	119.95
-----------------------------------	--------



Manual



MUSTANG M.I.T. 100 MANUAL INFLATABLE PFD MD2015 03

Inflates via manual inflation cord. Will self-right most wearers (face-up) once inflated. The M.I.T.100 offers a streamlined, comfortable and easy-to-wear solution for all day wear or quick trips on the water. Adjustable waist belt offers customized fit and can accommodate outerwear if needed. Large arm cut outs mean full mobility. Manual inflation handle slides away for safety, and is easily accessible when needed to deploy. Membrane Inflatable Technology means a light, flexible fit, and easy re-packing when it comes time to recharge. Provides 28 LBS of buoyancy when inflated - 1.5x regular foam PFDs. **Transport Canada Approved.**

- 10-1830K.....Grey199.95
- 10-1831K.....Red.....199.95
- 10-1832K.....Camo199.95
- 10-1902K.....REARM KIT (MA2014).....37.95

Automatic



MUSTANG M.I.T. 100 AUTOMATIC INFLATABLE PFD MD2017 03

Automatically inflates upon water immersion. Will self-right most wearers (face-up) once inflated. The MIT 100 offers a streamlined, comfortable and easy-to-wear solution no matter your adventure. The high tenacity nylon used in the face fabric allows this new version to be softer, more supple, and lighter weight than previous versions, and adds even more 'all day' to MIT 100's all-day comfort. Adjustable waist belt offers customized fit and can accommodate outerwear if needed. Large arm cut outs mean full mobility. Manual inflation handle is easily accessible when needed. Membrane Inflatable Technology means a light, flexible fit, and easy re-packing when it comes time to recharge. Provides 28 LBS of buoyancy when inflated - 1.5x regular foam PFDs. **Transport Canada Approved.**

- 10-1833K.....Grey219.95
- 10-1834K.....Red.....219.95
- 10-1835K.....Camo219.95
- 10-1902K.....REARM KIT (MA2014).....37.95



MUSTANG BELT PACK - MD3070 MD3070

This inflatable belt pack has a discrete minimalist design for inshore paddles and/or skilled swimmers who are looking for a little extra safety support. The minimalist design stays out of the way until activated. Soft exterior fabric and ergonomic construction make this PFD extremely comfortable to wear. It also includes Molle webbing to keep gear accessible and secure. Activated with a manual inflation cord, the Minimalist Belt Pack provides 18 lbs of buoyancy in a pillow-style bladder when deployed.

- 10-1950K.....Grey159.95
- 10-1951K.....Blue159.95
- 10-1840K.....Re-Arm Kit (MA3070)24.95



MUSTANG BELT EXTENDER

The belt extender allows wearers with larger size requirements to use most Mustang Survival inflatable PFD'S. **PLEASE NOTE: In Canada, wearing a belt extender voids the Canadian ULC approval for the PFD.**

- 10-006K.....1 1/2" Buckle (MA7637)22.95
- 10-007K.....2" Buckle (MA7632)22.95

Floatation

MARINE EQUIPMENT

Manual



MUSTANG M.I.T. 70 MANUAL INFLATABLE PFD MD4031

Inflates via manual inflation cord. We took our most loved inflatable and made it even more flexible, comfortable and lightweight - without compromising on durability, quality, or safety. The MIT 70 is the smallest inflatable PFD approved in North America, making it your new favourite vest to pack for every inshore adventure. Exclusive Membrane Inflatable Technology™ (M.I.T.) creates a lightweight, flexible fit. Manual inflation model activates by pulling the inflation handle. Provides 15.7 LBS of buoyancy when inflated. Easy-access inflator eases re-arming. High visibility, contrasting fabric when inflated for increased visibility in rescue scenarios. **Approval: Harmonized Level 70**

10-1940K	Red	169.95
10-1941K	Grey	169.95
10-1942K	Blue	169.95
10-1839K	REARM KIT (MA4031)	37.95

Automatic



MUSTANG M.I.T. 70 AUTOMATIC INFLATABLE PFD MD4032

Automatically inflates upon water immersion. We took our most loved inflatable and made it even more flexible, comfortable and lightweight - without compromising on durability, quality, or safety. The MIT 70 is the smallest inflatable PFD approved in North America, making it your new favourite vest to pack for every inshore adventure. Exclusive Membrane Inflatable Technology™ (M.I.T.) creates a lightweight, flexible fit. Automatic inflation model inflates upon water immersion. Provides 15.7 LBS of buoyancy when inflated. Easy-access inflator eases re-arming. High visibility, contrasting fabric when inflated for increased visibility in rescue scenarios. **Approval: Harmonized Level 70**

10-1945K	Red	199.95
10-1946K	Grey	199.95
10-1947K	Blue	199.95
10-1839K	REARM KIT (MA4031)	37.95



M.I.T. 100 INFLATABLE PFD

MD2017-T1 (Automatic)

A premium product at an affordable price, the M.I.T. 100 was designed with style. This easy to wear and easy to use inflatable PFD features Membrane Inflatable Technology inside to reduce product weight and create a lighter and more flexible fit. 500 Denier Cordura Orange outer shell. Exclusive Membrane Inflatable Technology inflation cell with reflective tape and safety whistle. Inflator inspection window and easy access flap. 1-fold easy to repack design. Provides 100N (26lb) buoyancy for typical boating activities. **More than 1.5 times the buoyancy of most foam PFD's.** Transport Canada Approved.

10-1933K	One Size	224.95
10-1902K	Re-Arm Kit (MA2014)	37.95



MUSTANG "AUTOMATIC" HYDROSTATIC INFLATOR

Same specs as the MD3153 above, only with additional features. MD3153-T2/T3 version has 64 square inches of SOLAS reflective tape and is designed for serious users. The back flap can be custom-screened for company or agency identification. This low profile PFD is designed to be worn in conjunction with Personal Protective Equipment (PPE) and lightweight and comfortable enough that you'll forget you're wearing a PFD. Popular with Coast Guard, Police, Search and Rescue personal, Construction sites. CCG Approved. Chest sizes, 32 to 52 inches. Age 16 yrs, weight 80lbs and over. Transport Canada Approved.

MD3153-T3 (Hi-Viz Yellow)	
10-003K	One Size

10-1822K	Hyd. Re-Arm Kit (MA7214)	91.50
----------------	--------------------------------	-------



ELITE INFLATABLE PFD MD5153

Built on a revolutionary 3D chassis, the Elite Inflatable PFD stays put at high speeds, lets you move the way you want and NEED to and provides automatic inflation powered by Hydrostatic Inflator Technology. The 3D chassis reduces drag at speed, the wide shoulder system eliminates neck fatigue, a wicking mesh liner improves all-day comfort, dual-side adjusters ease fit and an exclusive sleek inflation handle prevents snags. The bright fluorescent yellow-green inflation cell provides 28 lb buoyancy when inflated and improves visibility in a rescue scenario. Transport Canada Approved.

- 10-1934KBLACK.....349.95
- 10-1936KRED.....349.95
- 10-1937KREARM KIT (MA5183).....86.95



**Shop or Browse
Online 24/7
at
mercersmarine.com**



DELUXE INFLATABLE PFD WITH HIT (HYDROSTATIC ACTIVATION)

MD3153 (Automatic with Manual Back-up) & MD3154 (Automatic with Manual Back-up & Harness)

The Hydrostatic Inflator Technology offers reliable inflation in a low maintenance design that will only automatically inflate when submerged in 4 or more inches of water and not inadvertently due to rain, spray or humidity. Exclusive to Mustang Survival in North America and maintenance-free for 5 years or until inflated. Made for the most severe marine environments the Inflatable PFD with HIT will meet the challenges of the most demanding users. It also features the patented SecureZip closure system to ensure the PFD will stay closed during even the most rigorous activity and still opens effortlessly upon inflation. This lightweight and comfortable PFD can be worn over a T-shirt on warm days or over thicker garments in colder conditions. It is low profile and allows for maximum mobility. The neoprene Comfort Collar is soft on your neck and is part of a sleek design that is so comfortable you'll forget you're wearing a PFD. Universal sizing for adults 16 years+ weighing 80LBS+ with chest size of 30-52". Provides 35lb of buoyancy when inflated. **Twice the buoyancy of most foam PFD's.** Transport Canada Approved

- | | |
|---|--|
| MD3153 | MD3154 With Harness |
| 10-1814KRed/Black (One Size).....349.95 | 10-1816KRed/Black (One Size).....374.95 |
| 10-1815K.....Grey/Black (One Size)349.95 | 10-1817K.....Grey/Black (One Size)374.95 |
| 10-1822K.....Repl. Hydrostatic inflator (MA7214)..... | 91.50 |



AUTO HYDROSTATIC INFLATABLE PFD - HEAVY DUTY MD3157

We recommend this vest for Lobster and Crab fishermen who require extra durability due to wear from hauling pots. **This Inflatable Lifejacket with H.I.T.™ (Hydrostatic Inflator Technology) is the first Transport Canada approved lifejacket in Canada.** The Hydrostatic Inflator Technology offers reliable inflation in a low maintenance design that will only automatically inflate when submerged in 4 or more inches of water and not inadvertently due to rain, spray or humidity. Exclusive to Mustang Survival in North America and maintenance-free for 5 years or until inflated. Made for the most severe marine environments the inflatable PFD with H.I.T will meet the challenges of the most demanding users. 1F auto hydrostatic inflator technology. SecureZip™ closure. Light weight and comfortable design. Neoprene Comfort Collar™. Provides 35lb of buoyancy when inflated - **Twice the buoyancy of most foam PFD's.** Cylinder is contained inside bladder to protect against corrosion. Durable heavy duty polyurethane coated nylon. Strobe light holder, safety whistle and SOLAS reflective tape on inflation cell.

- 10-1820K.....One Size432.95
- Replacement Hydrostatic Re-Arming Kits**
- 10-1822KMA7214 (Old Pull Down Style).....91.50
- 10-1821K.....MA5283 (New Side Pull)86.95

Automatic



MUSTANG M.I.T. 100 AUTOMATIC INFLATABLE PFD - MD2040

Exclusive Membrane Inflatable Technology (MIT) and high-tenacity nylon fabric create a lightweight and durable PFD. Swapping between automatic and manual inflation modes is as easy as changing inflator caps; a zippered hip pocket lets you bring a spare wherever you go. The 1-fold design makes repacking the bladder after deployment simple, and there are no excuses for skipping safety checks with the convenient inflator window and access flap. The front entry buckle secures the vest while the design turns most wearers face up in the water. 28 lbs of buoyancy. **Transport Canada Approved.**

- 10-1827KRed244.95
- 10-1828KGrey244.95
- 10-1829KCamo244.95
- 10-1902KREARM KIT (MA2014).....37.95



MUSTANG RE-ARM KIT "F"

Model MA7113

(Equivalent to older model MA7170/MA7174/MA7270)

For use with Mustang Models:

MD3000/MD3001/MD3002/MD3003/MD3004/MD3010/MD3015/MD3017/MD3019/MD3020/MD3021/MD3025/MD3032/MD3090/MD3091
Kit includes 1 - 33 gram CO2 cylinder. 1 ready status indicator clip. 1 ready status indicator pin and 1 bobbin (for use with MD3001/MD3002/MD3017/MD3019/MD3031/MD3032)

- 10-1810K.....MA7113..... 37.95



MUSTANG RE-ARM KIT "E"

Model MA7114

(Equivalent to older model MA7202/MA7203)

For use with Mustang Models:

MD2051/MD2053/MD2981/MD2983/MD2951/MD2953/MD3051/MD3052/MD3053/MD3054/MD3071/MD3075/MD3081/MD3082/MD3083/MD3084/MD3085/MD3087.

Also compatible with MD2085 and MD2087.

Kit includes 1 - 33 gram CO2 cylinder. Bayonet assembly. 1 bobbin (for use with MD2053/MD2087/MD3053/MD3054/MD3083/MD3084/MD3087/MD2983/MD2953)

- 10-1811K.....MA7114..... 37.95



33g

Side Pull

MUSTANG RE-ARM KIT - 33G AUTO-HYDROSTATIC

Contains everything necessary to re-arm your Mustang Survival Auto Hydrostatic inflatable PFD after deployment. For inflatable PFD model numbers:

MD5283, MD5253, MD6284, and MD6254, MD3157v02, MD3188v02

- 10-1821K.....MA528386.95



Replacement Bobbin

Check your bobbin on a regular basis

Replacement Bobbin Only

- 10-773K.....MA921112.50



24g

MUSTANG RE-ARM KIT MA2014

For use with models MD2014, MD2015, MD2016, MD2017, MD4016

- 10-1902K.....MA201437.95



17g

MUSTANG RE-ARM KIT FOR MD4031/MD4032

For use with Models MD4031 and MD4032

- 10-1839K.....MA403137.95



Down Pull

MUSTANG RE-ARM KIT "C" (AUTO - HYDROSTATIC)

For use with Mustang Models:

MD3153/MD3154/MD3157/MD3183/MD3184/MD3188/Kit includes 1 - 33 gram CO2 cylinder/Inflator body. Inflator cap with plastic pull handle. Key.

- 10-1822K.....MA721491.50



24g



Side Pull

MUSTANG RE-ARM KIT - 24G AUTO-HYDROSTATIC

Contains everything necessary to re-arm your Mustang Survival Auto Hydrostatic inflatable PFD after deployment. Compatible with inflatable PFD model numbers: MD5183, MD5153

- 10-1937K.....MA518386.95



"CATALYST" FLOTATION JACKET MC5246 & MC5446

Safety, simplicity, and surefire warmth, all wrapped up in one does-it-all layer that lets you focus on your mission. The Catalyst Flotation Coat gives you the comfort, mobility and range of motion you want with the warmth your long days on the water won't compromise on. Kick the inconvenience of changing in and out of your PFD as you navigate on- and off-board with the PFD integrated directly into one elements-blocking jacket. Keep wind & moisture out with adjustable cuffs at the wrists. Stay covered up as you bend, twist and move with a longer cut that prevents riding up. The Catalyst Flotation Coat is your ultimate winter layer for the water. Field tested by Coast Guard training crews, fishing lodges and Mustang PRO-staff. Integrates seamlessly with Catalyst Flotation Bib Pants. **Approval: Harmonized Level 70**



Red/Black - Model MC5246 (Bomber Style)

10-1604K.....	Sm	546.95
10-1605K.....	Med	546.95
10-1606K.....	Lg	546.95
10-1607K.....	XL	546.95
10-1608K.....	2X	546.95
10-1609K.....	3X	546.95

Orange/Black - Model MC5246 (Bomber Style)

10-1610K.....	Sm	546.95
10-1611K.....	Med	546.95
10-1612K.....	Lg	546.95
10-1613K.....	XL	546.95
10-1614K.....	2X	546.95
10-1615K.....	3X	546.95

Black - Model MC5246 (Bomber Style)

10-1616K.....	Sm	546.95
10-1617K.....	Med	546.95
10-1618K.....	Lg	546.95
10-1619K.....	XL	546.95
10-1620K.....	2X	546.95
10-1621K.....	3X	546.95



Red/Black - Model MC5446 (3/4 Style)

10-1592K.....	Sm	546.95
10-1593K.....	Med	546.95
10-1594K.....	Lg	546.95
10-1595K.....	XL	546.95
10-1596K.....	2X	546.95
10-1597K.....	3X	546.95

Orange/Black - Model MC5446 (3/4 Style)

10-1598K.....	Sm	546.95
10-1599K.....	Med	546.95
10-1600K.....	Lg	546.95
10-1601K.....	XL	546.95
10-1602K.....	2X	546.95
10-1603K.....	3X	546.95

CATALYST FLOTATION PANTS MP4240

Waterproof, breathable, tri-laminate outer shell. Outer shell is waterproof to 10,000 mm with vapour transmission rate of 5,000 g/m2 per 24 hrs. Durable Cordura knee reinforcements. Fleece-lined hand warmer pockets. Adjustable suspenders. Zippered legs for easy donning over boots.

10-1886K.....	Sm	534.95
10-1887K.....	Med	534.95
10-1888K.....	Lg	534.95
10-1889K.....	XL	534.95
10-1890K.....	2XL	534.95
10-1891K.....	3XL	534.95



Optional Insulated Hoods Available. See Below.



“CLASSIC” FLOATER COATS

The Floater Model MC-1506 is our best selling Mustang coat. Enhanced waterproofing with new relaxed fit. Full length storm flap with zipper closure on front pockets. Please Note: Hoods are sold separately. **Approval:**

Harmonized Level 70

Orange

10-503K.....	Sm	386.95
10-504K.....	Med	386.95
10-505K.....	Lg	386.95
10-506K.....	XL	386.95
10-507K.....	2X	386.95
10-508K.....	3X	386.95

Optional Insulated Hood (Orange) MA7136-2

10-615K		134.95
---------------	--	--------

Red

10-509K.....	Sm	386.95
10-510K.....	Med	386.95
10-511K.....	Lg	386.95
10-512K.....	XL	386.95
10-513K.....	2X	386.95
10-514K.....	3X	386.95

Optional Insulated Hood (Red) MA7136-4

10-616K.....		134.95
--------------	--	--------

THERMOSYSTEM PLUS COAT

Model MC1536

Based on our award-winning technology, the MC1536 ThermoSystem Plus Coat delivers floatation with enhanced hypothermia protection. Featuring a neoprene beavertail to slow body temperature cooling by reducing cold water flushing, it also offers an insulated hood and neoprene wrist closures for weather protection. For extra comfort and functionality, the coat includes hand-warmer pockets, extra large hip pockets, underarm ventilation, SOLAS reflective tape for enhanced visibility and an interior radio pocket. Built with Mustang's High Performance Nylon™ and AirSoft™ floatation foam, the ThermoSystem Plus Coat is the product to trust when you can't leave safety to chance. **Approval: Harmonized Level 70**

10-219K.....	Sm	539.95
10-220K.....	Med	539.95
10-221K.....	Lg	539.95
10-222K.....	XL	539.95
10-223K.....	2X	539.95
10-224K.....	3X	539.95



ANSI HIGH VISIBILITY FLOATATION COAT

Model MC1506 T3

Made with high visibility ANSI fluorescent Yellow Green fabric and ANSI reflective tape for CSA Z96-2009 and WCB compliance and water safety.

Based on the original Mustang Floater Coat, this CSA compliant High Visibility Flotation Coat is engineered to provide comfort, warmth, and durability. Most importantly, the Coat's closed-cell foam insulation will provide floatation and in-water insulation to delay the onset of hypothermia in the event of accidental water immersion. Combined with functional elements such as large front pockets and a full-length storm flap, this coat adds up to an unbeatable value.

Approval: Harmonized Level 70

10-233K.....	Sm	537.95
10-234K.....	Med	537.95
10-235K.....	Lg	537.95
10-236K.....	XL	537.95
10-237K.....	2X	537.95
10-238K.....	3X	537.95



CLASSIC FLOATATION BIB PANT

Model MP4212

Designed to be worn with the Classic Flotation Bomber Jacket or the Classic Flotation Coat, Mustang Survival's Classic Flotation Bib Pant provides foam insulation that will not only keep you warm during regular marine activities but will also increase your hypothermia protection in the event of cold water immersion. With adjustable elasticized suspenders and zippered legs, these pants are easy to don over boots and provide a great fit. A hit with boaters, fisherman and commercial and agency operators, the Classic Flotation Bib Pant serves as functional and comfortable outerwear.

When worn with a Mustang Survival flotation jacket or coat, flotation bib pants provide superior buoyancy and hypothermia protection to keep you safe and warm during all of your marine activities.

Black

10-031K.....	Sm	478.95
10-032K.....	Med	478.95
10-033K.....	Lg	478.95
10-034K.....	XL	478.95
10-035K.....	2X	478.95





INTEGRITY MS195 HX SUIT

New HX design. Adjustable hood with one hand tighteners. Water resistant Comfort Cuff can be tightened to prevent water from entering sleeve. Ripstop nylon knee and seat reinforcements. Abrasion-resistant hem reinforcement. Two cargo pockets and hand warmer pockets. Tug-tites at ankles and thighs to minimize water flushing.

Transport Canada Approved

Red/Carbon

10-1428KXS856.95
10-1429KSm856.95
10-1430KMed856.95
10-1431KLg856.95
10-1432KXL856.95
10-1433K2XL856.95
10-1434K3XL856.95



MS2195 FLOATER SUITS

Designed with Mustang Airsoft foam for a lighter and more comfortable fit than the Classic Floatation Suit. Featuring two chest pockets, large front cargo pockets and an inflatable head pillow for additional in-water support and buoyancy, this suit blends functionality and features to meet the demands of a wide-range of professional and industrial uses. Mustang Survival floatation suits are designed to protect the wearer from foul or cold weather, and use closed-cell foam to offer floatation and hypothermia protection in the event of water immersion. SOLAS reflective tape enhances visibility and an insulated hood is easily stowed in the collar for convenience. Transport Canada Approved

Orange/Black

10-227KSm862.95
10-228KMed862.95
10-229KLg862.95
10-230KXL862.95
10-231K2X862.95
10-232K3X862.95



MS-185 FLOATER SUITS

The MS-185 "Classic" floater suit is an industry leader, constructed with renowned MUSTANG quality. Features include: Tug-tites at thighs and ankles. Velcro closures on wrists and ankles. S.O.L.A.S. retro reflective tape. Insulated hood. Mustangs "Airsoft" foam for comfort.

Transport Canada Approved

Orange

10-040KXS649.95
10-041KSm649.95
10-042KMed649.95
10-043KLg649.95
10-044KXL649.95
10-045KXXL649.95
10-046KXXXL649.95





Work and Safety Wear

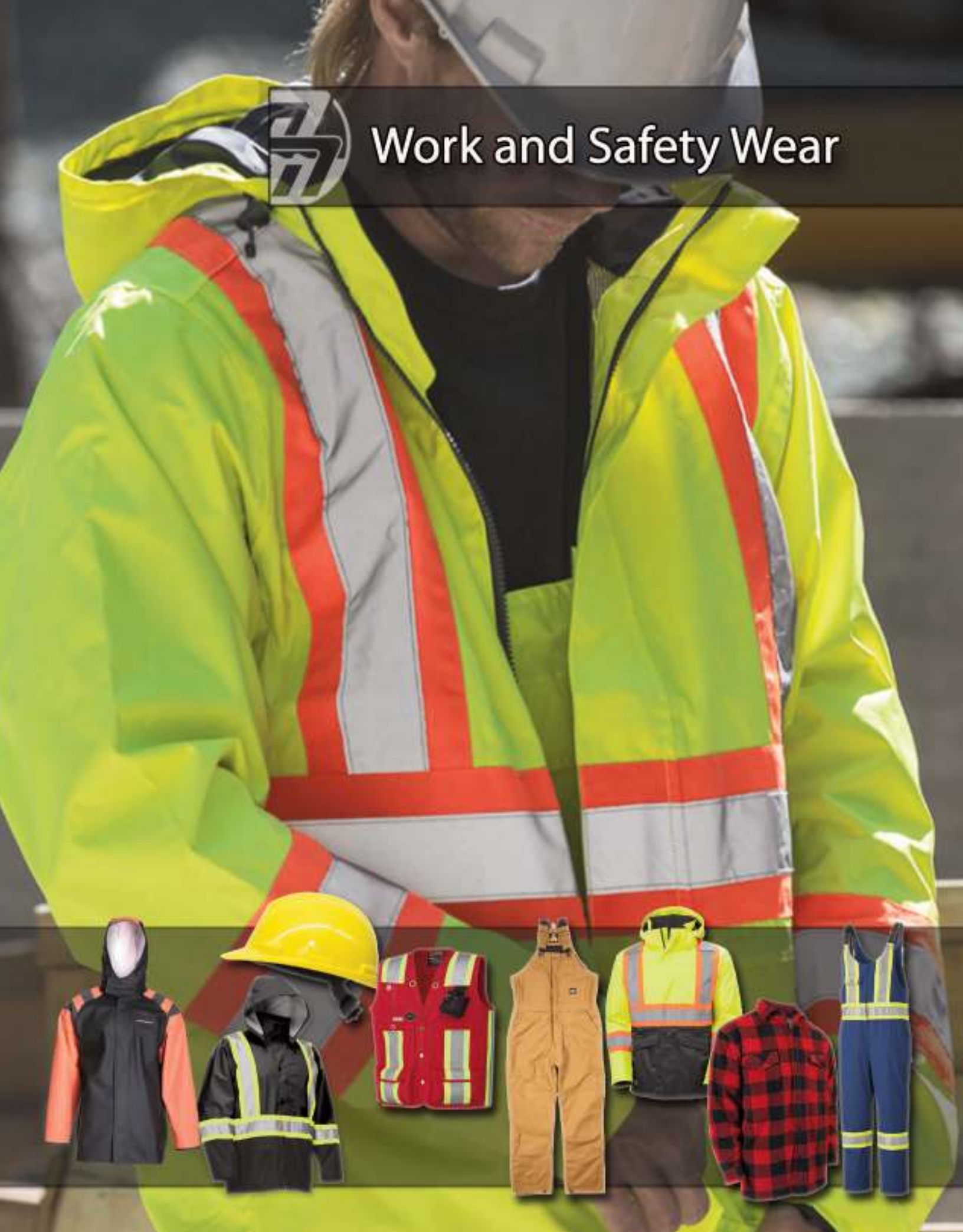



RANPRO CANADIAN CLASSIC (RANGER)

Ranpro Canadian Classic (Also called "Ranger") PVC clothing is made from exceptionally strong, tear resistant 13 oz./yd. PVC on polyester. Electronically welded seams. Withstands abrasion and is quick drying when wet. Resistant to fish and marine oils.

Jacket Model J35

18-616K.....Sm	74.95
18-617K.....Med	74.95
18-618K.....Lg	74.95
18-619K.....XL	74.95
18-620K.....2X	74.95
18-621K.....3X	74.95
18-622K.....4X	74.95

Bib Pants Model P35

18-624K.....Sm	72.95
18-625K.....Med	72.95
18-626K.....Lg	72.95
18-627K.....XL	72.95
18-628K.....2X	72.95
18-629K.....3X	72.95
18-630K.....4X	72.95

RANPRO "SL-35-155" 17" SLEEVES

100% waterproof and windproof. Fabric is resistant to all marine and fish oils. Electronically welded seams ensure water tightness. Increased softness and cold flex in the harshest conditions. Increased tear and wear resistance. Sleeves are 17" in length.

SL35-155 Sleeves - Green

16-302M.....One Size	29.95
----------------------------	-------



RANPRO GREEN SNAPPER

Ranpro Green Snapper (Also called "Ranger") is specially treated PU/PVC on polycotton. Waterproof seams resistant to marine and fish oils. 14.5oz./yard fabric. Corrosion resistant brass snap closures.

JACKET WITH HOOD

18-722K.....Sm	104.95
18-723K.....Med	104.95
18-724K.....Lg	104.95
18-725K.....XL	104.95
18-726K.....2X	104.95
18-727K.....3X	104.95
18-728K.....4X	104.95

DOUBLE BIB PANTS

18-729K.....Sm	87.95
18-730K.....Med	87.95
18-731K.....Lg	87.95
18-732K.....XL	87.95
18-733K.....2X	87.95
18-734K.....3X	87.95
18-735K.....4X	87.95

RANPRO "FL" SNAPPER

Ranpro FL Snapper (Also called "Ranger") PVC Polycotton is more supple than before providing better flexibility in cold conditions. Attached hood with drawcord. Durable brass corrosion resistant covered snaps on front closure, inner stormflap with brass snaps to keep water out. Double bib design allows pant top be turned around to double the wear. Durable elastic suspenders with spreader bar. Roomy fit.

JACKET WITH HOOD

18-708K.....Sm	113.95
18-709K.....Med	113.95
18-710K.....Lg	113.95
18-711K.....XL	113.95
18-712K.....2X	113.95
18-713K.....3X	113.95
18-714K.....4X	113.95

DOUBLE BIB PANTS

18-715K.....Sm	103.95
18-716K.....Med	103.95
18-717K.....Lg	103.95
18-718K.....XL	103.95
18-719K.....2X	103.95
18-720K.....3X	103.95
18-721K.....4X	103.95



RANPRO DEFENDER

The Ranpro Jacket/Overalls have a premium soft and flexible PVC material made from heavyweight PVC/Poly/PVC, providing excellent protection against fish and animal fats, motor oil, and a wide range of chemicals and light acids. The hooded jacket and bib pants are 100% windproof and waterproof, with strong triple-welded seams to help users stay active, dry, and protected in most weather conditions. The pants have a double bib with premium elastic suspenders that have easy-connect hooks, whereas the jacket has a 3-pc adjustable drawstring hood.

DEFENDER JACKET - GREEN

18-635K.....Sm	54.95
18-636K.....Med	54.95
18-637K.....Lg	54.95
18-638K.....XL	54.95
18-639K.....2X	54.95
18-640K.....3X	54.95
18-641K.....4X	54.95
18-642K.....5X	54.95

DEFENDER BIB PANTS - GREEN

18-644K.....Sm	52.95
18-645K.....Med	52.95
18-646K.....Lg	52.95
18-647K.....XL	52.95
18-648K.....2X	52.95
18-649K.....3X	52.95
18-650K.....4X	52.95
18-651K.....5X	52.95

NEW



VIKING NORSEMAN SUIT

100% Waterproof and windproof. Medium to heavy risk chemical splash protection. Excellent chemical protection against acids, animal fats, and motor oils. Good protection against foul weather wind and cold protection. Ideal for fish/food processing as tough, sandwich fabric will not delaminate with exposure to animal or fish oil.

JACKET (3125J)

18-316K.....Sm	48.95
18-317K.....Med	48.95
18-318K.....Lg	48.95
18-319K.....XL	48.95
18-320K.....2X	50.95
18-321K.....3X	50.95

PANT (3110P)

18-323K.....Sm	48.95
18-324K.....Med	48.95
18-325K.....Lg	48.95
18-326K.....XL	48.95
18-327K.....2X	50.95
18-328K.....3X	50.95

SHOP 24/7 FROM THE COMFORT OF YOUR OWN HOME

- Up to date Pricing
- New Products
- Stock Status
- Additional product info
- And more



www.mercersmarine.com





HELLY HANSEN "ENGRAM" JACKET & PANT (FORMALLY ERIKSENS)

JACKET FEATURES: One of our most popular suits. Hard wearing PVC for the toughest jobs on the water. Resistance to fish and oil, sunlight, mildew and seawater. Attached, generously cut 3 panel hood. Inside storm flap. Concealed rust resistant snap closures. Microweld seams. Cold crack rated to -30C.

PANT FEATURES: Hard wearing PVC for the toughest jobs on the water. Resistance to fish and oil, sunlight, mildew and seawater. Side gusset for easy entry. Adjustable suspenders. Can be worn back to front. Microweld seams. Cold crack rated to -30C.

ENGRAM JACKET (70123)

18-000KXS145.95
18-001KSm145.95
18-002KMed145.95
18-003KLg145.95
18-004KXL145.95
18-005K2X145.95
18-006K3X145.95
18-007K4X145.95
18-008K5X145.95

ENGRAM BIB PANTS (70124)

18-012KXS132.95
18-013KSm132.95
18-014KMed132.95
18-015KLg132.95
18-016KXL132.95
18-017K2X132.95
18-018K3X132.95
18-019K4X132.95
18-020K5X132.95



HELLY HANSEN "ARMOUR" JACKET & PANT

JACKET FEATURES: Tear resistant outershell of durable, high tenacity 420 denier nylon. Inner layer of 170g/m2 PU coated nylon knit Impertech waterproof fabric. Generously cut 3 panel drawcord hood with cordlocks. Improved inner and outer stormflap for durability. Improved stormcuffs for comfort and dryness. Concealed stainless steel rust resistant snap closure. Inner layer has microwelded seams.

PANT FEATURES: Tear resistant outershell of durable, high tenacity 420 denier nylon. Inner layer of 170g/m2 PU coated nylon knit Impertech waterproof fabric. Side gusset for easy entry. Adjustable suspenders. Quick release buckles. Inner layer has microwelded seams.

ARMOUR JACKET (70201)

18-438KSm248.95
18-439KMed248.95
18-440KLg248.95
18-441KXL248.95
18-442K2X248.95
18-443K3X248.95
18-464K4X248.95
18-465K5X248.95

ARMOUR BIB PANTS (70501)

18-444KSm235.95
18-445KMed235.95
18-446KLg235.95
18-447KXL235.95
18-448K2X235.95
18-449K3X235.95
18-466K4X235.95
18-467K5X235.95



ABBOTSFORD FOUL WEATHER SUITS FROM HELLY HANSEN

A superior PU coated nylon which is exceptionally light weight, comfortable & virtually noiseless for hunting. This garment has a "stretch factor" & all seams are microwelded which makes this garment 100% waterproof.



ABBOTSFORD JACKET -70193 (FORMALLY IT600)

18-258K.....Sm (Olive).....	132.95
18-259K.....Med (Olive).....	132.95
18-260K.....Lg (Olive).....	132.95
18-261K.....XL (Olive).....	132.95
18-262K.....2X (Olive).....	132.95
18-281K.....3X (Olive).....	132.95
18-282K.....4X (Olive).....	132.95
18-283K.....5X (Olive).....	132.95

18-263K.....Sm (Orange).....	132.95
18-264K.....Med (Orange).....	132.95
18-265K.....Lg (Orange).....	132.95
18-266K.....XL (Orange).....	132.95
18-267K.....2X (Orange).....	132.95
18-284K.....3X (Orange).....	132.95
18-285K.....4X (Orange).....	132.95
18-286K.....5X (Orange).....	132.95

ABBOTSFORD BIB PANTS - 70592 (FORMALLY IT800)

18-268K.....Sm (Olive).....	128.95
18-269K.....Med (Olive).....	128.95
18-270K.....Lg (Olive).....	128.95
18-271K.....XL (Olive).....	128.95
18-272K.....2X (Olive).....	128.95
18-287K.....3X (Olive).....	128.95
18-288K.....4X (Olive).....	128.95
18-289K.....5X (Olive).....	128.95

18-273K.....Sm (Orange).....	128.95
18-274K.....Med (Orange).....	128.95
18-275K.....Lg (Orange).....	128.95
18-276K.....XL (Orange).....	128.95
18-277K.....2X (Orange).....	128.95
18-278K.....3X (Orange).....	128.95
18-279K.....4X (Orange).....	128.95
18-280K.....5X (Orange).....	128.95

Luna Jacket - Green (70286)

18-578K.....XS.....	128.95
18-579K.....Sm.....	128.95
18-580K.....Med.....	128.95
18-581K.....Lg.....	128.95
18-582K.....XL.....	128.95
18-583K.....2X.....	128.95

Luna Jacket - Navy (70286)

18-585K.....XS.....	128.95
18-586K.....Sm.....	128.95
18-587K.....Med.....	128.95
18-588K.....Lg.....	128.95
18-589K.....XL.....	128.95
18-590K.....2X.....	128.95

Luna Pant - Green (70486)

18-592K.....XS.....	68.95
18-593K.....Sm.....	68.95
18-594K.....Med.....	68.95
18-595K.....Lg.....	68.95
18-596K.....XL.....	68.95
18-597K.....2X.....	68.95

Luna Pant - Navy (70486)

18-599K.....XS.....	68.95
18-600K.....Sm.....	68.95
18-601K.....Med.....	68.95
18-602K.....Lg.....	68.95
18-603K.....XL.....	68.95
18-604K.....2X.....	68.95



HELLY HANSEN LADIES LUNA JACKET

The Luna Rain jacket has the great womens fit that the Luna products are known for – design by women for women. The PU main fabric ensures the user stays dry when the sky opens up and the rain comes down. Packable hood in collar. Adjustable hood with elastic drawcord. Double main fabric front flap. Napoleon pocket with YKK zipper and hole for head phones. Hand pockets. Neoprene cuffs. Adjustable hem with elastic drawcord. Extended back for improved comfort.

HELLY HANSEN LADIES LUNA PANTS

Elastic waist. Adjustable hem. 4-way stretch fabric. Comfortable knit backing. 100% waterproof fabric and construction. Environmentally friendly PVC-coating.



HELLY HANSEN GALE JACKET

Gale Jacket sets the new standard in rain gear built for workers! Phthalate free fabrics ensure low environmental impact while at the same time keeping you dry no matter the weather. YKK center front zipper. Double main fabric front flap. Napoleon pocket with YKK zipper and hole for head phones. Hand pockets. Packable hood with draw cord adjustment at front. Neoprene cuffs. Inner pocket. Bottom hem adjustment with cord. Extended back for better comfort. ID card loop.

Gale Jacket - Green (70282)

18-541KXS128.95
18-542KSm128.95
18-543KMed128.95
18-544KLg128.95
18-545KXL128.95
18-546K2X128.95
18-547K3X128.95
18-548K4X128.95

Gale Jacket - Orange (70282)

18-550KXS128.95
18-551KSm128.95
18-552KMed128.95
18-553KLg128.95
18-554KXL128.95
18-555K2X128.95
18-556K3X128.95
18-557K4X128.95

HELLY HANSEN GALE PANT

Gale Rain Pant sets the new standard in rain gear built for workers! Phthalate free fabrics ensure low environmental impact while at the same time keeping you dry no matter the weather. Elastic at waist. Adjustable waist.

Gale Pant - Green (70582)

18-559KXS94.95
18-560KSm94.95
18-561KMed94.95
18-562KLg94.95
18-563KXL94.95
18-564K2X94.95
18-565K3X94.95
18-566K4X94.95

Gale Pant - Orange (70582)

18-568KXS94.95
18-569KSm94.95
18-570KMed94.95
18-571KLg94.95
18-572KXL94.95
18-573K2X94.95
18-574K3X94.95
18-575K4X94.95



HELLY HANSEN STORM RAIN JACKET

Storm jacket sets the new standard in rain gear built for fishing. Phthalate free fabrics ensure low environmental impact while at the same time keeping you dry no matter the weather. Double main fabric front flap. Napoleon pocket with zipper and hole for headphones. No shoulder seams. Hood with draw cord adjustment at front and velcro adjustment at back. Neoprene cuffs. Inner pocket. Extended back for better comfort. ID card loop.

Storm Jacket - Orange/Black (70283)

18-505KXS192.95
18-506KSm192.95
18-507KMed192.95
18-508KLg192.95
18-509KXL192.95
18-510K2X192.95
18-511K3X192.95
18-512K4X192.95

Storm Jacket - Green (70283)

18-514KXS192.95
18-515KSm192.95
18-516KMed192.95
18-517KLg192.95
18-518KXL192.95
18-519K2X192.95
18-520K3X192.95
18-521K4X192.95

HELLY HANSEN STORM RAIN PANT

Storm bib sets the new standard in rain gear built for fishing. Phthalate free fabrics ensure low environmental impact while at the same time keeping you dry no matter the weather. Inner chest pocket with zipper. Elastic suspenders. Button adjustment in waist.

Storm Pant - Orange/Black (70583)

18-523KXS124.95
18-524KSm124.95
18-525KMed124.95
18-526KLg124.95
18-527KXL124.95
18-528K2X124.95
18-529K3X124.95
18-530K4X124.95

Storm Pant - Green (70583)

18-532KXS124.95
18-533KSm124.95
18-534KMed124.95
18-535KLg124.95
18-536KXL124.95
18-537K2X124.95
18-538K3X124.95
18-539K4X124.95

GRUNDÉNS



GRUNDENS FATHOM JACKET & PANTS

A great all-around choice for commercial fishermen. Fathom uses a rugged 480 g/m² polyester/cotton that offers both abrasion and tear resistance, with an improved drying time over traditional cotton backed fabrics. Coated with a mixture of PVC/Polyurethane, offering greater flexibility in cold temperatures while retaining the high abrasion resistance of PVC. Tailored with a trimmer, active fit that offers a higher cut for added chest protection.

FATHOM JACKET - GREEN

18-2569KXS149.95
18-2570KSm149.95
18-2571KMed149.95
18-2572KLg149.95
18-2573KXL149.95
18-2574K2X149.95
18-2575K3X149.95
18-2576K4X149.95
18-2577K5X149.95

FATHOM BIB PANTS - GREEN

18-2578KXS129.95
18-2579KSm129.95
18-2580KMed129.95
18-2581KLg129.95
18-2582KXL129.95
18-2583K2X129.95
18-2584K3X129.95
18-2585K4X129.95
18-2586K5X129.95



NEW

Zipper Closure



FATHOM JACKET - YELLOW/GREY

18-2515KXS184.95
18-2516KSm184.95
18-2517KMed184.95
18-2518KLg184.95
18-2519KXL184.95
18-2520K2X184.95
18-2521K3X184.95

FATHOM BIB PANTS - YELLOW/GREY

18-2524KXS139.95
18-2525KSm139.95
18-2526KMed139.95
18-2527KLg139.95
18-2528KXL139.95
18-2529K2X139.95
18-2530K3X139.95

GRUNDÉNS



Zipper Closure



GRUNDENS BALDER ZIP JACKET

The Balder is a professional hooded jacket tailored from rugged material that delivers superior oil resistance and excellent cold weather protection. No longer features button closures. The new version of this jacket is now equipped with a zipper closure. Robust construction combined with essential professional features make the Balder Jacket an ideal choice for hard working fisherman in cold climates.

GRUNDENS BALDER BIB PANT

Features: Cut to enhance mobility while improving mechanical ventilation, preventing overheating during strenuous activity, width adjustment with snap button makes it easy to create a custom fit, construction also features a solid upper panel to increase durability and extend the garment's service life, heavy-duty eyelets for the attachment of fishing tools, a roomy inside security pocket and reinforced leg cuffs to prevent wear in this critical area, a new bib suspender/buckle design that prevents unintended release while making it easy to dress for action.

BALDAR ZIP JACKET - ORANGE/BLACK

18-1991KXS259.95
18-1992KSm259.95
18-1993KMed259.95
18-1994KLg259.95
18-1995KXL259.95
18-1996K2X259.95
18-1997K3X274.95

BALDAR BIB PANTS - ORANGE/BLACK

18-2009KXS209.95
18-2010KSm209.95
18-2011KMed209.95
18-2012KLg209.95
18-2013KXL209.95
18-2014K2X209.95
18-2015K3X224.95





GRUNDENS

Zipper Closure

GRUNDENS HAULER JACKET

Built with double-coated PVC polyester material, this no-nonsense jacket is a leading choice of professional fishermen worldwide. Its fit gives fishermen the ability to layer underneath and keep working in the face of everything the sea throws their way. Double PVC-Coated Polyester. 100% Waterproof. Reinforced Body. Internal Neoprene Cuff. Adjustable Hood. Active Fit.

HAULER ZIP JACKET - YELLOW/GREY

18-2533KXS234.95
18-2534KSm234.95
18-2535KMed234.95
18-2536KLg234.95
18-2537KXL234.95
18-2538K2X234.95
18-2539K3X249.95
18-2540K4X249.95
18-2541K5X249.95

HAULER ZIP JACKET - ORANGE/GREY

18-2542KXS234.95
18-2543KSm234.95
18-2544KMed234.95
18-2545KLg234.95
18-2546KXL234.95
18-2547K2X234.95
18-2548K3X249.95
18-2549K4X249.95
18-2550K5X249.95

GRUNDENS HAULER BIB PANT

The Grundens Hauler Bib is built with double coated PVC polyester material. So it's a great choice for professional fisherman worldwide. Pairs perfectly with the Grundens Hauler Jacket. The relaxed fit of this bib offers anglers the best freedom of movement possible. Provides great protection against rain, spray, and wind. Double PVC-Coated Polyester. 100% Waterproof. Reinforced Lower. Double Layered Front. Interior Chest Pocket. Knee Pad Pocket. Active Fit.

HAULER BIB PANTS - YELLOW/GREY

18-2551KXS216.95
18-2552KSm216.95
18-2553KMed216.95
18-2554KLg216.95
18-2555KXL216.95
18-2556K2X216.95
18-2557K3X232.50
18-2558K4X232.50
18-2559K5X232.50

HAULER BIB PANTS - ORANGE/GREY

18-2560KXS216.95
18-2561KSm216.95
18-2562KMed216.95
18-2563KLg216.95
18-2564KXL216.95
18-2565K2X216.95
18-2566K3X232.50
18-2567K4X232.50
18-2568K5X232.50



GRUNDENS

GRUNDENS CLIPPER 82 JACKET

Tailored from medium weight PVC-coated polyester/cotton blend fabric with a relaxed fit and set-in sleeves for ease of movement, this professional jacket provides 100% waterproof protection for hard-working fishermen. An adjustable drawstring hood, hidden button closure and double-buttoned storm flap help seal out water and spray in even the toughest conditions. A good choice for layering in cold, rainy environments.

GRUNDENS CLIPPER 116 BIB PANT

A great all-around choice for professional fishermen, these medium weight PVC-coated polyester/cotton blend bibs are tailored for a trimmer, active fit and offer a higher cut for added chest protection. These bibs deliver both the 100% waterproof protection and rugged durability fishermen expect. Sturdy replaceable suspenders with quick-release clips make it easy to get Clipper bibs on and off. Designed to be reversible from front to back, for added convenience as well as extended service life.

CLIPPER 82 JACKET - ORANGE

18-2120KXS149.95
18-2121KSm149.95
18-2122KMed149.95
18-2123KLg149.95
18-2124KXL149.95
18-2125K2X149.95
18-2126K3X159.95
18-2127K4X159.95
18-2128K5X159.95

CLIPPER 116 BIB PANTS - ORANGE

18-2138KXS149.95
18-2139KSm149.95
18-2140KMed149.95
18-2141KLg149.95
18-2142KXL149.95
18-2143K2X149.95
18-2144K3X159.95
18-2145K4X159.95
18-2146K5X159.95



GRUNDENS NEPTUNE 319 JACKET

This full-zippered hooded jacket is made from medium-weight polyurethane-coated polyester fabric for the waterproof protection, comfort and easy movement active fishermen need. An athletic cut and underarm gussets deliver protection without restricting fishing action. Features like adjustable cuffs and cord-lock hem and hood adjustments keep even wind-driven rain and spray at bay. Grundens' three-piece hood design provides full coverage without restricting visibility.

NEPTUNE 319 JACKET - GREEN

18-2301KXS109.95
18-2302KSm109.95
18-2303KMed109.95
18-2304KLg109.95
18-2305KXL109.95
18-2306K2X109.95
18-2307K3X114.95

NEPTUNE 319 JACKET - ORANGE

18-2310KXS109.95
18-2311KSm109.95
18-2312KMed109.95
18-2313KLg109.95
18-2314KXL109.95
18-2315K2X109.95
18-2316K3X114.95

GRUNDENS NEPTUNE 509 BIB PANT

These polyurethane coated polyester bib trousers give fishermen the lower-body protection they demand with the freedom and comfort to fish hard all day long. Tailored for an active fit, this medium-weight fabric stretches and moves with every on-deck task, while providing 100% waterproof protection against the elements. Professional features include gear storage, ankle cinch hem closures and adjustable suspenders with an elastic holder for ease and convenience when answering nature's call.

NEPTUNE 509 BIB PANTS - GREEN

18-2337KXS109.95
18-2338KSm109.95
18-2339KMed109.95
18-2340KLg109.95
18-2341KXL109.95
18-2342K2X109.95
18-2343K3X114.95

NEPTUNE 509 BIB PANTS - ORANGE

18-2346KXS109.95
18-2347KSm109.95
18-2348KMed109.95
18-2349KLg109.95
18-2350KXL109.95
18-2351K2X109.95
18-2352K3X114.95



GRUNDENS Ladies



GRUNDENS LADIES NEPTUNE JACKET & PANTS

Designed by women for women, our product team had the commercial fisherman front of mind when building the Neptune Jacket. Made from medium-weight PU material and a balance of fit and stretch, you have 100% waterproof protection and ease of movement required for long hard days on deck. The Neptune Jacket and pants has strategically placed pockets and added adjustable features that will come in handy when you least expect it.

LADIES NEPTUNE JACKET - BLUE

18-2870KXS109.95
18-2871KSm109.95
18-2872KMed109.95
18-2873KLg109.95
18-2874KXL109.95
18-2875K2X109.95

LADIES NEPTUNE BIB PANTS - BLACK

18-2888KXS109.95
18-2889KSm109.95
18-2890KMed109.95
18-2891KLg109.95
18-2892KXL109.95
18-2893K2X109.95



NEW



GRUNDENS



GRUNDENS FULL SHARE HOODED JACKETS

When you get your hands on the new Full Share Jacket you will instantly notice the rugged exterior fabric, strategically placed technical features, and an interior membrane that offers strong resistance to the most common contaminants fisherman face. Initially designed for the commercial fisherman, the Full Share jacket offers a top performing waterproof/breathable solution with next to skin comfort that benefits the sportfishing enthusiast as well, and at an incredible value. 2 zipper hand pockets. Waterproof and Windproof. YKK Aquaguard Zips. Adjustable cuffs. Adjustable hood. Reflective logos. Active Fit

FULL SHARE JACKET - YELLOW/BLACK

18-2895KXS149.95
18-2896KSm149.95
18-2897KMed149.95
18-2898KLg149.95
18-2899KXL149.95
18-2900K2X149.95
18-2901K3X149.95

FULL SHARE JACKET - ORANGE/GREY

18-2807KXS149.95
18-2808KSm149.95
18-2809KMed149.95
18-2810KLg149.95
18-2811KXL149.95
18-2812K2X149.95
18-2813K3X149.95

FULL SHARE JACKET - BLACK

18-2816KXS149.95
18-2817KSm149.95
18-2818KMed149.95
18-2819KLg149.95
18-2820KXL149.95
18-2821K2X149.95
18-2822K3X149.95

FULL SHARE JACKET - RED

18-2834KXS149.95
18-2835KSm149.95
18-2836KMed149.95
18-2837KLg149.95
18-2839KXL149.95
18-2840K2X149.95

NEW



GRUNDENS



GRUNDENS FULL SHARE BIB PANTS

When you get your hands on the new Full Share Bib you will instantly notice the rugged exterior fabric, strategically placed technical features, and an interior membrane that offers strong resistance to the most common contaminants fisherman face. Initially designed for the commercial fisherman, the Full Share bib offers a top performing waterproof/breathable solution with next to skin comfort that benefits the sportfishing enthusiast as well, and at an incredible value. Single storage chest pocket. Grundens adjustable suspenders. Lower leg zippers for easy on/off over boots. Reflective logos. Articulated knees Side mesh panels. Active Fit.

FULL SHARE BIB PANTS - YELLOW

18-2904KXS134.95
18-2905KSm134.95
18-2906KMed134.95
18-2907KLg134.95
18-2908KXL134.95
18-2909K2X134.95
18-2910K3X134.95

FUL SHARE BIB PANTS - ORANGE/GREY

18-2843KXS134.95
18-2844KSm134.95
18-2845KMed134.95
18-2846KLg134.95
18-2847KXL134.95
18-2848K2X134.95
18-2849K3X134.95

FULL SHARE BIB PANTS - BLACK

18-2852KXS134.95
18-2853KSm134.95
18-2854KMed134.95
18-2855KLg134.95
18-2856KXL134.95
18-2857K2X134.95
18-2858K3X134.95



WETSKINS FW SUIT

PVC outer laminated to nylon inner fabric. Jacket features billed hood with cordlocks on drawstrings. Zipper front closure with snap storm flap. Ventilation front and back yoke. Underarm eyelets. 2 bellows front pockets with snap closure flaps. Pants feature elastic waist. Ankle and fly snaps.

18-206K.....Sm	52.95
18-207K.....Med	52.95
18-208K.....Lg	52.95
18-209K.....XL	52.95
18-210K.....2X	52.95
18-211K.....3X	52.95

STORMFRONT RAINSUIT

Jacket Features: 100% polyester outer with PVC coating. Fully taped seams. Full front nylon zipper with snap storm front placket. 2 front pockets. Hide-away hood and zippered collar. Elastisized inner wrist cuffs. Bottom drawcord. Pants feature: Elastisized waist. 2 slash pockets. Botton ankle snaps. Handy carry case.

Forest Green

18-190P.....Sm	42.25
18-191P.....Med	42.25
18-192P.....Lg	42.25
18-193P.....XL	42.25
18-194P.....2X	42.25

Camo

18-196P.....Med	45.95
18-197P.....Lg	45.95
18-198P.....XL	45.95
18-199P.....2X	45.95



SOU'WESTERS

A traditional East Coast styled rain hat offering full weather protection for days on the water when the rain just won't quit!

The wide brim and deep fit keeps rain off your face and funnels rain away from your collar. the chinstrap will keep the sea gale from snatching your hat, and the cotton lining will keep you comfortable, no matter how nasty the weather.

18-991P.....One Size	14.50
----------------------------	-------





JACKFIELD PVC RAINWEAR

100% waterproof and windproof. Made of very resistant PVC/nylon (0.60mm) treated to prevent stiffness and cracking when under cold temperatures. Resistant to seawater, effects of sunlight, animal and vegetal fats, grease, fish oils, motor oils, chemicals and acids. The PVC is treated to be resistant to flames, but it doesn't have any valid certification in Canada. Generous sizing for appropriate adjustment and the comfort of the user.

JACKET: Heavy duty rustproof snaps. Front with double storm flap and drain pipe system. 100% waterproof heat welded seams. Four hidden rustproof snap closure at the front. Permanent hood with adjustable drawstring. One rustproof snap at the hood for a better adjustment.

PANTS: Double-bib pants can be reversed. 100% waterproof heat welded seams. Adjustable waist with heavy duty rustproof snaps. High quality heavy duty suspenders.

Jacket - Green

18-4300K.....Sm	72.95
18-4301K.....Med	72.95
18-4302K.....Lg.....	72.95
18-4303K.....XL.....	72.95
18-4304K.....2X.....	84.95
18-4305K.....3X.....	84.95
18-4306K.....4X.....	84.95

Bib Pant - Green

18-4309K.....Sm	72.95
18-4310K.....Med	72.95
18-4311K.....Lg.....	72.95
18-4312K.....XL.....	72.95
18-4313K.....2X.....	84.95
18-4314K.....3X.....	84.95
18-4315K.....4X.....	84.95

MERCER'S
210 MARINE DRIVE, CLARENVILLE, NL

Visit us online at
www.mercersmarine.com

Our website has
Up to Date Pricing & Live Inventory

TEL: 709.466.7430
info@mercersmarine.com

NEW



Available
in
Mens and
Ladies

JACKFIELD PVC/PU JACKET

100% waterproof and windproof. Made of resistant PVC/polyurethane with polyester backing. Treated to prevent stiffness and cracking when under cold temp. Resists to seawater, effects of sunlight, grease, fish oils, motor oils, chemicals and acids. Generous sizing for appropriate adjustment. 100% waterproof heat welded seams.

JACKET- Front with double storm flap and drain pipe system. Front closure with zipper and heavy duty hidden rustproof snaps. Permanent hood with adjustable drawstring each side and at the back. Inner neoprene cuffs with strap and Velcro.

PANTS- Inner pocket with zipper at the chest. Elastic with snap button on each side for a better fit. High quality adjustable heavy duty suspenders. Internal knee pad pocket. Reflective stripes at the legs. Snap adjustment at the leg cuff.

Mens Jacket - Grey/Green

18-4364K.....Sm	104.95
18-4365K.....Med	104.95
18-4366K.....Lg.....	104.95
18-4367K.....XL.....	104.95
18-4368K.....2X.....	118.95
18-4369K.....3X.....	118.95
18-4370K.....4X.....	118.95

Ladies Jacket - Grey/Green

18-4382K.....XS.....	104.95
18-4383K.....Sm	104.95
18-4384K.....Med	104.95
18-4385K.....Lg.....	104.95
18-4386K.....XL.....	104.95
18-4387K.....2X.....	118.95
18-4388K.....3X.....	118.95

Mens Bib Pants - Grey/Green

18-4373K.....Sm	104.95
18-4374K.....Med	104.95
18-4375K.....Lg.....	104.95
18-4376K.....XL.....	104.95
18-4377K.....2X.....	118.95
18-4378K.....3X.....	118.95
18-4379K.....4X.....	118.95

Ladies Bib Pants - Grey/Green

18-4391K.....XS.....	104.95
18-4392K.....Sm	104.95
18-4393K.....Med	104.95
18-4394K.....Lg.....	104.95
18-4395K.....XL.....	104.95
18-4396K.....2X.....	118.95
18-4397K.....3X.....	118.95

NEW



JACK FIELD



NEW



JACK FIELD

JACKFIELD POLYURETHANE RAINWEAR

100% waterproof and windproof. Polyester coated with extensible high quality polyurethane. Treated to prevent stiffness and cracking when under cold temperatures. Resists to seawater, to effects of sunlight, to animal, vegetal and synthetic fats, grease, to fish oil, to motor oil, to chemical products and to acids. Generous sizing. 100% waterproof heat welded seams. **Jacket**-Adjustable hood with string. One chest pocket. Two waist cargo pockets. Snaps at cuffs for a better adjustment. **Pants**-One side pocket. Elastic at waist. Adjustable waistband with drawstring. Zipper at the leg. Heavy duty rustproof snap on the bottom of the legs for a better adjustment.

Jacket - Grey/Yellow

18-4334KXS86.95
18-4335KSm86.95
18-4336KMed86.95
18-4337KLg86.95
18-4338KXL86.95
18-4339K2X99.95
18-4340K3X99.95
18-4341K4X99.95

Waist Pants - Grey

18-4344KXS37.95
18-4345KSm37.95
18-4346KMed37.95
18-4347KLg37.95
18-4348KXL37.95
18-4349K2X43.95
18-4350K3X43.95
18-4351K4X43.95

JACKFIELD POLYURETHANE BIB PANTS

Windproof and waterproof. High quality stretch polyurethane coated polyester. Treated to be less rigid and not to crack when subjected to low temperatures. Resistant to sea water, prolonged exposure to the sun, animal, vegetable and synthetic fats, fish oil, motor oil, chemicals and acids. Loose fit. Stitched and heat welded seams. Inner pocket with zipper at the chest. Elastic with snap button on each side for a better fit. High quality adjustable heavy duty suspenders. Internal knee pad pocket.

Bib Pants - Grey

18-4355KSm48.95
18-4356KMed48.95
18-4357KLg48.95
18-4358KXL48.95
18-4359K2X55.95
18-4360K3X55.95
18-4361K4X55.95

NEW

JACK FIELD



JACK FIELD



JACKFIELD ULTIMATE FISHING SUIT

100% waterproof and windproof. Made of resistant 600D oxford nylon with polyurethane coating. Extra strong reinforcement fabric on the sleeves and front. 72% nylon / 16% polyester / 12% polyurethane. **JACKET**- Front with double storm flap and drain pipe system. Front closure with zipper YKK and heavy duty hidden rustproof snaps. 100% waterproof heat welded seams. Hood with front and rear adjustments. 3M reflective stripes on the shoulders. Inner neoprene cuffs with strap and Velcro. **PANTS** - Sides with rib for a better fit. Inner pocket with zipper at the chest. Internal knee pad pocket. High quality adjustable heavy duty suspenders. 3M reflective stripes at the legs.

Jacket - Orange/Grey

18-4400KSm259.95
18-4401KMed259.95
18-4402KLg259.95
18-4403KXL259.95
18-4404K2X299.95
18-4405K3X299.95
18-4406K4X299.95

Bib Pants - Orange/Grey

18-4409KSm189.95
18-4410KMed189.95
18-4411KLg189.95
18-4412KXL189.95
18-4413K2X219.95
18-4414K3X219.95
18-4415K4X219.95





HI-VIZ LIGHTWEIGHT SAFETY JACKET & PANTS

Jacket: 150 denier PU coated polyester. 100% waterproof and windproof. CSA Z96-09 Class 2 Level 2 (Class 3 when combined with matching pant). Taped and heat sealed seams. Multiple front and back vents. Fully lined. Adjustable wrists. 2 large front cargo pockets. Detachable and adjustable hood, folds into comfort fleece collar. Full front zipper with Velcro storm flap. **Pants :** 150 PU coated denier polyester. 100% waterproof and windproof. CSA Z96-09 Class 3 Level 2 when combined with matching jacket. Taped and heat sealed seams. Elastic suspenders with quick-release clips. Boot access zippers with adjustable ankles. Fly access.

ORANGE JACKET (MODEL 5594)

18-1000M.....XS.....	79.95
18-1001M.....Sm.....	79.95
18-1002M.....Med.....	79.95
18-1003M.....Lg.....	79.95
18-1004M.....XL.....	79.95
18-1005M.....2X.....	79.95
18-1006M.....3X.....	79.95
18-1007M.....4X.....	79.95

YELLOW JACKET (MODEL 5596)

18-1008M.....XS.....	79.95
18-1009M.....Sm.....	79.95
18-1010M.....Med.....	79.95
18-1011M.....Lg.....	79.95
18-1012M.....XL.....	79.95
18-1013M.....2X.....	79.95
18-1014M.....3X.....	79.95
18-1015M.....4X.....	79.95

ORANGE PANT (MODEL 5595)

18-1016M.....XS.....	43.95
18-1017M.....Sm.....	43.95
18-1018M.....Med.....	43.95
18-1019M.....Lg.....	43.95
18-1020M.....XL.....	43.95
18-1021M.....2X.....	43.95
18-1022M.....3X.....	43.95
18-1023M.....4X.....	43.95

YELLOW PANT (MODEL 5597)

18-1024M.....XS.....	43.95
18-1025M.....Sm.....	43.95
18-1026M.....Med.....	43.95
18-1027M.....Lg.....	43.95
18-1028M.....XL.....	43.95
18-1029M.....2X.....	43.95
18-1030M.....3X.....	43.95
18-1031M.....4X.....	43.95



PIONEER STRETCH HI-VIZ FR LONG RAINCOAT

FR treated 100% polyurethane/poly. Meets CGSB 155.20, 2000 Type 3. CSA Z96-09 Class 3 Level 2. Oil and chemical resistant. 100% waterproof and windproof. Lightweight and tough 4-way stretch PU. FR retroreflective tape. Heat welded seams. Extra-large detachable hood. Full front zipper with snap closure storm flap. **Style 5897**

18-1809M.....XS.....	159.95
18-1810M.....Sm.....	159.95
18-1811M.....Med.....	159.95
18-1812M.....Lg.....	159.95
18-1813M.....XL.....	159.95
18-1814M.....2X.....	159.95
18-1815M.....3X.....	159.95
18-1816M.....4X.....	159.95
18-1817M.....5X.....	159.95



VIKING HI-VIZ "FR" PU SAFETY JACKET & PANTS

A light weight alternative to PVC with a high level of waterproofness. Stretchable, reinforced seams for better flexibility. Good resistance to Chemicals such as Animal Fats, Fish Oil, Motor Oil, and Diesel Fuel. Fully compliant with CSA Z96-09 Class 1, Level FR. Meets testing method of CAN/CGSB-4.2 No.27.10 & ASTM D6413 Flame Resistance. 2" 3M Scotchlite Reflective Material in 4" Contrasting Configuration.

JACKET (6055FRJG)

18-1819M.....Sm.....	109.95
18-1820M.....Med.....	109.95
18-1821M.....Lg.....	109.95
18-1822M.....XL.....	109.95
18-1823M.....2X.....	109.95
18-1824M.....3X.....	109.95
18-1825M.....4X.....	109.95

PANTS (6055FRPG)

18-1828M.....Sm.....	79.95
18-1829M.....Med.....	79.95
18-1830M.....Lg.....	79.95
18-1831M.....XL.....	79.95
18-1832M.....2X.....	79.95
18-1833M.....3X.....	79.95
18-1834M.....4X.....	79.95



PIONEER "THE ROCK" HI-VIZ WATERPROOF SAFETY JACKET

100% waterproof 300D oxford polyester with PU coating. CSA Z96-15 Class 2 Level 2 (becomes Class 3 when worn with hi-viz pant featuring reflective leg bands). ANSI/ISEA 107-15 Class 3 Type P and R. StarTech reflective tape. Taped and heat sealed seams. Superior tear- and abrasion-resistant fabric. Liberal fit and full back vent for working comfort. 2 lower flap pockets. Half mesh lined vented back. Full front zipper. Hood folds into collar.

Jacket - Yellow (5628)

18-1130M.....Sm	60.95
18-1131M.....Med	60.95
18-1132M.....Lg.....	60.95
18-1133M.....XL.....	60.95
18-1134M.....2X.....	60.95
18-1135M.....3X.....	60.95
18-1136M.....4X.....	60.95
18-1137M.....5X.....	60.95

Jacket - Orange (5626)

18-1139M.....Sm	60.95
18-1140M.....Med	60.95
18-1141M.....Lg.....	60.95
18-1142M.....XL.....	60.95
18-1143M.....2X.....	60.95
18-1144M.....3X.....	60.95
18-1145M.....4X.....	60.95
18-1146M.....5X.....	60.95

PIONEER "THE ROCK" HI-VIZ WATERPROOF SAFETY BIB PANT

100% waterproof 300D oxford polyester with PU coating. CSA Z96-15 Class 3 Level 2 when worn with Class 2 Level 2 top featuring reflective arm bands. ANSI/ISEA 107-15 Class E Supplemental Type. StarTech reflective tape. Taped and heat sealed seams. Superior tear- and abrasion-resistant fabric. Liberal fit for working comfort. Elastic suspenders. High-quality plastic buckles. 2 snap adjustment on leg hems to fit snug to boots. 2-sided waist adjustment for better fit around waist.

Bib Pant - Yellow (5629)

18-1148M.....Sm	42.95
18-1149M.....Med	42.95
18-1150M.....Lg.....	42.95
18-1151M.....XL.....	42.95
18-1152M.....2X.....	42.95
18-1153M.....3X.....	42.95
18-1154M.....4X.....	42.95
18-1155M.....5X.....	42.95

Bib Pant - Orange (5627)

18-1157M.....Sm	42.95
18-1158M.....Med	42.95
18-1159M.....Lg.....	42.95
18-1160M.....XL.....	42.95
18-1161M.....2X.....	42.95
18-1162M.....3X.....	42.95
18-1163M.....4X.....	42.95
18-1164M.....5X.....	42.95



DYNAMIC HARD HAT

Hard hat with rain trough HDPE shell foam liner 4-point - nylon suspension with "Sure-Lock" Ratchet adjustable suspension 4 anchor points for chin strap. Meets CSA Type 2 Class E and ANSI Type II Class E standards.

50-350K.....White	39.95	50-354K.....Red.....	39.95
50-351K.....Yellow.....	39.95	50-355K.....Orange.....	39.95
50-352K.....Pink.....	39.95		





WAVERLY STORMSUIT (70620)

18-481K.....XS.....	214.95
18-482K.....Sm.....	214.95
18-483K.....Med.....	214.95
18-484K.....Lg.....	214.95
18-485K.....XL.....	214.95
18-486K.....2XL.....	214.95
18-487K.....3XL.....	214.95
18-488K.....4XL.....	214.95
18-489K.....5XL.....	214.95

HELLY HANSEN "WAVERLY" STORMSUIT

Common Features: Taped seams. 3M Scotchlite Reflective Material. **Waterproof.** **Jacket Features:** Zipper front closing with external stormflap. Stand-up corduroy lined collar. Vented chest and back. Two front patch pockets with snap closures. Snap adjustment at sleeve hem. Removable drawcord hood serves as carrying case. **Bib Pant Features:** Adjustable suspenders. Velcro closing fly. Snap adjustment at waist and leg hem.



PIONEER HI-VIZ WATERPROOF PARKA

450 denier oxford polyester with PU backing. CSA Z96-09 Class 2 Level 2. Class 3 when combined with style #5586 or #5576. StarTech reflective tape. Inner zipper to accommodate optional 3-in-1 zip-in fleece liner #6925 or #6924 (see page 318). 100% waterproof and windproof. Fully mesh lined. Taped and heat sealed seams. 2 front pockets. Full front zipper with snap storm placket. Detachable snap hood. Storm cuffs

PIONEER HI-VIZ WATERPROOF PANTS

450 denier oxford polyester with PU backing. CSA Z96-09 Class 3 Level 2 when worn combined with #5585A or #5575A. StarTech™ reflective tape. 100% waterproof and windproof. Taped and heat sealed seams. Two pass-through pockets. Elastic waist. Rear pocket.

YELLOW JACKET (5585A)

13-7985M.....Sm.....	92.95
13-7986M.....Med.....	92.95
13-7987M.....Lg.....	92.95
13-7988M.....XL.....	92.95
13-7989M.....2X.....	92.95
13-7990M.....3X.....	92.95

YELLOW PANTS (5586)

13-7991M.....Sm.....	44.95
13-7992M.....Med.....	44.95
13-7993M.....Lg.....	44.95
13-7994M.....XL.....	44.95
13-7995M.....2X.....	44.95
13-7996M.....3X.....	44.95

ORANGE JACKET (5575A)

13-8956M.....Sm.....	92.95
13-8957M.....Med.....	92.95
13-8958M.....Lg.....	92.95
13-8959M.....XL.....	92.95
13-8960M.....2X.....	92.95
13-8961M.....3X.....	92.95

ORANGE PANTS (5576)

13-8964M.....Sm.....	44.95
13-8965M.....Med.....	44.95
13-8966M.....Lg.....	44.95
13-8967M.....XL.....	44.95
13-8968M.....2X.....	44.95
13-8969M.....3X.....	44.95



FORCEFIELD

NEW



FORCEFIELD

NEW



FORCEFIELD

NEW



FORCEFIELD 450D HI VIS SAFETY RAIN JACKET WITH SNAP-OFF HOOD

Total compliance with the newest CSA standard: CSA Z96-15; Orange and Lime meet Class 2 Level 2 and Black meets Class 1 level 2. Total compliance with the newest ANSI standard: ANSI 107-2015; Orange and Lime meet Type R Class 3 and Black meets Type O Class 1. 100% polyester oxford, polyurethane coated. Mesh lining with inside pockets. Water-resistant (up to 8000mm) and wind-proof fabric, fully seam-sealed. Full-length, two-way, heavy-duty front zip with spring-loaded snap closure storm flap. Adjustable velcro at cuff. Two lower loss-proof pockets. Detachable snap-off hood, rib-knit storm cuffs.

Jacket - Yellow

18-5000M Sm	18-5004M2X
18-5001M.....Med	18-5005M3X
18-5002MLg	18-5006M4X
18-5003MXL	

Jacket - Orange

18-5009M Sm	18-5013M2X
18-5010M.....Med	18-5014M3X
18-5011MLg	18-5015M4X
18-5012MXL	

Jacket - Black

18-5018M Sm	18-5022M2X
18-5019M.....Med	18-5023M3X
18-5020MLg	18-5024M4X
18-5021MXL	

All Forcefield Hi Vis Safety Rain Jackets \$59.95

FORCEFIELD

NEW



FORCEFIELD

NEW



FORCEFIELD

NEW



FORCEFIELD 450D HI VIS SAFETY RAIN OVERALLS

Complete your spring hi-vis look with these water-resistant (up to 8000mm) and wind-proof safety rain overalls. 100% polyester oxford, polyurethane coated. 100% polyester lining. Water-resistant (up to 8000mm) and wind-proof fabric. Fully seam-sealed. Heavy-duty adjustable elastic straps. Riveted stress points. Cut for comfort and ease. Overall worn with CSA Z96 top meets CSA Class 3 Level 2.

Overalls - Yellow

18-5027M Sm	18-5031M2X
18-5028MMed	18-5032M3X
18-5029MLg	18-5033M4X
18-5030MXL	

Overalls - Orange

18-5036M Sm	18-5040M2X
18-5037M.....Med	18-5041M3X
18-5038MLg	18-5042M4X
18-5039MXL	

Overalls - Black

18-5045M Sm	18-5049M2X
18-5046MMed	18-5050M3X
18-5047MLg	18-5051M4X
18-5048MXL	

All Forcefield Hi Vis Safety Rain Overalls \$36.95





ALLROUNDWORK 37.5 INSULATOR JACKET

An insulated work jacket that keeps you warm and comfortable in cold environments. Combining the innovative 37.5® technology with warming insulation, the jacket offers great body-temperature management during intense activities. 37.5® technology for enhanced moisture management. Insulation for extra warmth in cold environments. CORDURA stretch panels provide mobility and durability. Pre-bent sleeves.

Black - Model 81010

11-25079M.....Sm	185.95
11-25080M.....Med	185.95
11-25081M.....Lg.....	185.95
11-25082M.....XL.....	185.95
11-25083M.....2X.....	185.95
11-25084M.....3X.....	185.95

Blue - Model 81019

11-25085M.....Sm	185.95
11-25086M.....Med	185.95
11-25087M.....Lg.....	185.95
11-25088M.....XL.....	185.95
11-25089M.....2X.....	185.95
11-25090M.....3X.....	185.95



ALLROUNDWORK WINTER JACKET (MODEL 1148)

Wind- and water-resistant winter jacket with great fit for optimum comfort and true all-round performance at work. Plenty of space for profiling. Wind and water resistant outer fabric. Ripstop fabric and coated inside for extra durability. Dropped back and windproof collar. Reflective piping for enhanced visibility. Hand-warming pockets, ID-badge holder, inside chest pen pockets.

11-25936M.....Sm	199.95
11-25937M.....Med	199.95
11-25938M.....Lg.....	199.95
11-25939M.....XL.....	199.95
11-25940M.....2X.....	199.95
11-25941M.....3X.....	199.95

Workwear



ALLROUNDWORK INSULATED JACKET (MODEL 1100)

An everyday use insulated work jacket built with 37.5 technology to provide reliable working comfort in cold environments. The jacket is suitable for profiling and combines protection and flexibility to make you ready for everything. 37.5 technology for enhanced moisture management. Fleece-lined collar for extra warmth and comfort. CORDURA reinforcements. Pre-bent sleeves. Reflective details. ID-badge holder inside the chest pocket.

Black

11-25091M.....Sm	280.95
11-25092M.....Med	280.95
11-25093M.....Lg.....	280.95
11-25094M.....XL.....	280.95
11-25095M.....2X.....	280.95
11-25096M.....3X.....	280.95



ALLROUNDWORK WATERPROOF INSULATED JACKET (MODEL 1102)

Waterproof insulated work jacket that provides everyday comfort in cold and wet environments. This all-purpose work jacket features 37.5 technology, taped seams and detachable hood. 37.5 padding and 3D mesh lining at the back. Pre-bent sleeves and stretch panels at back of shoulder. Dropped back and sleeve ends for extra comfort. Fleece-lined, wind-protective high collar and inner elastic cuffs with thumbholes. Waterproof detachable hood, reflective details and zip chest pocket with attachment for ID badge.

Steel Grey

11-25097M.....Sm	356.95
11-25098M.....Med	356.95
11-25099M.....Lg.....	356.95
11-25100M.....XL.....	356.95
11-25101M.....2X.....	356.95
11-25102M.....3X.....	356.95



SNICKERS SERVICE VEST (MODEL 4548)

Wind and water-resistant winter vest with great fit for optimum comfort and true all-round performance at work. Plenty of space for profiling. Protects against wind. Insulated construction. Reflective piping.

11-25360M.....Sm	166.95
11-25361M.....Med	166.95
11-25362M.....Lg.....	166.95
11-25363M.....XL.....	166.95
11-25364M.....2X.....	166.95
11-25365M.....3X.....	166.95



SNICKERS ALLROUND WORK OVERALLS (MODEL 6051)

Classic bib and brace work trousers made of a soft cotton and polyester fabric. The trousers feature elastic rib at upper sides and 4-way stretch at back for optimal fit and comfort. In addition, the garment comes with adjustable braces, chest pocket with zipper, pre-bent legs and KneeGuard system. Soft cotton and polyester fabric. Elastic rib at sides and 4-way stretch at back for optimal fit and comfort. Elastic, adjustable braces. KneeGuard system with CORDURA stretch reinforcements. Chest pocket with zipper and compartments, and leg pocket with attachment for ID badge.

Black	Waist x Inseam	
11-25960M	30 x 30	190.95
11-25961M	32 x 30	190.95
11-25962M	33 x 30	190.95
11-25963M	34 x 30	190.95
11-25964M	36 x 30	190.95
11-25965M	38 x 30	190.95
11-25966M	40 x 30	190.95
11-25967M	42 x 30	190.95
11-25968M	44/46 x 30	190.95
11-25970M	30 x 32	190.95
11-25971M	32 x 32	190.95
11-25972M	33 x 32	190.95
11-25973M	34 x 32	190.95
11-25974M	36 x 32	190.95
11-25975M	38 x 32	190.95
11-25976M	40 x 32	190.95
11-25977M	42 x 32	190.95
11-25978M	44/46 x 32	190.95

Navy	Waist x Inseam	
11-25980M	30 x 30	190.95
11-25981M	32 x 30	190.95
11-25982M	33 x 30	190.95
11-25983M	34 x 30	190.95
11-25984M	36 x 30	190.95
11-25985M	38 x 30	190.95
11-25986M	40 x 30	190.95
11-25987M	42 x 30	190.95
11-25988M	44/46 x 30	190.95
11-25990M	30 x 32	190.95
11-25991M	32 x 32	190.95
11-25992M	33 x 32	190.95
11-25993M	34 x 32	190.95
11-25994M	36 x 32	190.95
11-25995M	38 x 32	190.95
11-25996M	40 x 32	190.95
11-25997M	42 x 32	190.95
11-25998M	44/46 x 32	190.95

ALLROUNDWORK FULL STRETCH PANTS (MODEL 6371)

Multi-purpose work trousers with full stretch for optimal mobility. Made of durable 4-way stretch fabric, the trousers offer the comfort needed to work efficiently everyday all year round. Stretch CORDURA at knees. CORDURA tool holders. Ruler pocket with knife fastener. Cargo pocket with ID card attachment.

Steel Grey

11-25043M	28 W x 32 L (044)	236.95
11-25044M	30 W x 32 L (046)	236.95
11-25045M	32 W x 32 L (048)	236.95
11-25046M	33 W x 32 L (050)	236.95
11-25047M	34 W x 32 L (052)	236.95
11-25048M	36 W x 32 L (054)	236.95
11-25049M	38 W x 32 L (056)	236.95
11-25050M	40 W x 32 L (058)	236.95
11-25051M	42 W x 32 L (060)	236.95
11-25052M	44/46 W x 32 L (062)	236.95
11-25053M	48 W x 32 L (064)	236.95
11-25520M	32 W x 30 L (096)	236.95
11-25521M	33 W x 30 L (100)	236.95
11-25522M	34 W x 30 L (104)	236.95
11-25523M	36 W x 30 L (108)	236.95
11-25524M	38 W x 30 L (112)	236.95
11-25525M	40 W x 30 L (116)	236.95
11-25526M	42 W x 30 L (120)	236.95
11-25527M	44/46 W x 30 L (124)	236.95



XTR D30 CRAFTSMAN KNEEPADS (MODEL 9191)

Advanced knee protection for work that involves extended periods of frequent kneeling. D30 material retains the shape for long durations while offering extra impact protection. A lightweight design and supportive ventilation provide flexibility and comfort.

11-25806M	One Size	87.95
-----------	----------	-------



D30 LITE CRAFTSMAN KNEEPADS (MODEL 9112)

Kneepads offering advanced knee protection during work that involves frequent kneeling. Designed to reduce strain during everyday use, the D30® LITE material provides impact protection, ventilation and a lightweight construction.

11-25807M	One Size	54.95
-----------	----------	-------



CRAFTSMAN KNEEPADS (MODEL 9110)

Kneepads offering advanced knee protection during work that involves frequent kneeling. Designed to reduce strain, the lightweight, flexible and durable kneepads provide everyday working comfort.

11-25808M	One Size	41.95
-----------	----------	-------



ALLROUNDWORK STRETCH PANTS (MODEL 6341)

Workwear goes street smart in these stretchy work trousers that feature slimmer legs for a clean look. Stretch CORDURA at the knees combined with 4-way stretch at the back provide great flexibility and comfort. Holster pockets for added functionality. KneeGuard system for optimal knee protection. CORDURA-reinforced ruler- and cargo pockets. Pre-bent legs. Tool holder.

Black

11-25001M.....28 W x 30 L (088)	169.95
11-25002M.....30 W x 30 L (092)	169.95
11-25003M.....32 W x 30 L (096)	169.95
11-25004M.....33 W x 30 L (100)	169.95
11-25005M.....34 W x 30 L (104)	169.95
11-25006M.....36 W x 30 L (108)	169.95
11-25007M.....38 W x 30 L (112)	169.95
11-25008M.....40 W x 30 L (116)	169.95
11-25009M.....42 W x 30 L (120)	169.95
11-25010M.....44/46 W x 30 L (124)	169.95

Steel Grey

11-25022M.....28 W x 30 L (088)	169.95
11-25023M.....30 W x 30 L (092)	169.95
11-25024M.....32 W x 30 L (096)	169.95
11-25025M.....33 W x 30 L (100)	169.95
11-25026M.....34 W x 30 L (104)	169.95
11-25027M.....36 W x 30 L (108)	169.95
11-25028M.....38 W x 30 L (112)	169.95
11-25029M.....40 W x 30 L (116)	169.95
11-25030M.....42 W x 30 L (120)	169.95
11-25031M.....44/46 W x 30 L (124)	169.95

11-25011M.....28 W x 32 L (44)	169.95
11-25012M.....30 W x 32 L (46)	169.95
11-25013M.....32 W x 32 L (48)	169.95
11-25014M.....33 W x 32 L (050)	169.95
11-25015M.....34 W x 32 L (052)	169.95
11-25016M.....36 W x 32 L (054)	169.95
11-25017M.....38 W x 32 L (056)	169.95
11-25018M.....40 W x 32 L (058)	169.95
11-25019M.....42 W x 32 L (060)	169.95
11-25020M.....44/46 W x 32 L (062)	169.95
11-25021M.....48 W x 32 L (064)	169.95

11-25032M.....28 W x 32 L (044)	169.95
11-25033M.....30 W x 32 L (046)	169.95
11-25034M.....32 W x 32 L (048)	169.95
11-25035M.....33 W x 32 L (050)	169.95
11-25036M.....34 W x 32 L (052)	169.95
11-25037M.....36 W x 32 L (054)	169.95
11-25038M.....38 W x 32 L (056)	169.95
11-25039M.....40 W x 32 L (058)	169.95
11-25040M.....42 W x 32 L (060)	169.95
11-25041M.....44/46 W x 32 L (062)	169.95

ALLROUNDWORK 37.5 INSULATED PANTS PANTS (MODEL 6619)

Stay warm at work in these trousers lined with advanced 37.5[®]insulation for excellent ventilation and climate control. Made from durable Polyamide fabric, with advanced cut for great functionality and protection. Cordura reinforced kneepad pockets designed for the KneeGuard Pro with expansion pleats positioning system for superior knee protection.

Each leg is striped with heat sealed reflective tape for increased visibility when working in dark conditions.

Great pockets for all your things. Ruler pocket, cargo pocket, mobile phone pocket, large back pockets, hammer holders on both sides and ID-badge on leg pocket.

Long zippers at the sides for easy dressing. Adjustable leg ends attachable to the shoe straps to keep the trousers from sliding up.

Black

11-25103M.....Sm	257.95
11-25104M.....Med	257.95
11-25105M.....Lg	257.95
11-25106M.....XL	257.95
11-25107M.....2X	257.95



ALLROUNDWORKWORK 2-PACK WOOL SOCKS (MODEL 9213)

Merino wool keeps your feet warm and fresh. Air channels and mesh structure in hot spots provide extra ventilation to keep your feet dry and comfortable. Knitted rib at arch for optimal fit

11-25812M.....Sm/Med	23.95
11-25813M.....Lg/XL	23.95



RUFFWORK 2-PACK WOOL SOCKS (MODEL 9206)

Merino wool keeps your feet warm and fresh. Cordura reinforced toes and heels for superior durability. Terry on the inside provides extra warmth and comfort. Left and right shaped and knitted rib at arch for optimal fit. Air channels and mesh structure in hot spots provide extra ventilation to keep your feet dry and comfortable.

11-25810M.....Sm/Med	47.95
11-25811M.....Lg/XL	47.95



SNICKERS RW LONG JOHN SET (MODEL 9445)

Baselayer jersey and long johns made of thin polyester-and-cotton fabric that provides efficient moisture transport, warmth and comfort in chilly conditions.

11-25836MXS136.95
11-25837MSm136.95
11-25838MMed136.95
11-25839MLg136.95
11-25840MXL136.95
11-25841M2X136.95
11-25365M3X136.95



SNICKERS SERVICE COVERALLS (MODEL 6073)

Contemporary design that provides large areas for company profiling, including on the pockets. Ergonomic cut with pre-bent sleeves and pre-bent legs for maximum freedom of movement. Made of durable yet lightweight fabric for superior long-lasting comfort and protection. Front pockets, access pockets and chest pocket with easy-access pen compartments for added convenience. Long 2-way zipper makes it easy to pull on and off. Material: CoolTwill. A lightweight yet durable and dirt-repellent fabric. 65% Polyester, 35% Cotton, 200 g/m².

11-25500MSm130.95
11-25501MMed130.95
11-25502MLg130.95
11-25503MXL130.95
11-25504M2X130.95
11-25505M3X130.95



SNICKERS WEATHER DRY GLOVES (MODEL 9579)

The bad weather gloves. Durable polyurethane palm material together with the waterproof lining makes great gloves for bad weather conditions. Work safer in the dark with reflective knuckles.

16-2006MSm (8)95.95
16-2007MMed (9)95.95
16-2008MLg (10)95.95
16-2009MXL (11)95.95
16-2010M2X (12)95.95



SNICKERS LOGO BEANIE (MODEL 9084)

Cozy fleece lining for warm working comfort on chilly days. Soft and stretchable fabric for optimum fit and comfort. Contemporary design with Snickers Workwear logo.

11-25823MOne Size34.95
-----------	---------------	------------



FISHERMAN BEANIE (MODEL 9023)

Casual wool fisherman beanie that works just as well on the scaffolding as in the street. Combining great fit with contemporary vintage looks, this is the ultimate choice for style and comfort in all kinds of everyday environments

11-25821MNavy43.95
11-25822MGreen43.95



SNICKERS WEATHER FLEX DRY GLOVES (MODEL 9562)

Flexible and weather-protective work glove that provides great dexterity and comfort during lighter work in wet and chilly conditions. The glove is made of a 2-layer waterproof fabric and comes with soft, insulating fleece on the inside for extra warmth. Silicone print at palm and fingers for optimal grip.

16-2017MMed (9)56.95
16-2018MLg (10)56.95
16-2019MXL (11)56.95



SNICKERS WEATHER FLEX CUT GLOVES (MODEL 9317)

Keep your hands protected and warm. High cut protection (level 5) with excellent comfort and insulation properties. Seamless work gloves with brushed inside. Half coated in latex with grip pattern.

16-2014MMed (9)36.95
16-2015MLg (10)36.95
16-2016MXL (11)36.95

REVERSIBLE BEANIE (MODEL 9015)

Reversible warmth on top. Soft and cosy reversible beanie with contemporary oversized design for more relaxed look.

11-25820MOne Size36.95
-----------	---------------	------------



LADIES ALLROUNDWORK INSULATED JACKET (MODEL 1107)

Insulated women's work jacket ideal for everyday use. The jacket comes with a fleece-lined collar and 37.5 technology that provide warmth and moisture management. Wind-protective collar and elastic cuffs with thumbholes provide extra warmth and protection while pre-bent sleeves, stretch panels at the back and an adjustable bottom hem ensure flexibility and ease of movement. In addition, the jacket features reflective details for enhanced visibility and safety when working in high risk environments.

11-25770MXS	277.95
11-25771MSm	277.95
11-25772MMed	277.95
11-25773MLg	277.95
11-25774MXL	277.95
11-25775M2X	277.95



LADIES INSULATED JACKET (MODEL 8107)

Versatile work jacket with Repeve polyester insulation offering smooth warmth and comfort in cold conditions. The jacket also features the innovative 37.5 technology that provides extra ventilation for efficient body-temperature management even during intense work. Stretch panels add durability and flexibility, making this jacket a great choice for most types of work.

11-25750MXS	185.95
11-25751MSm	185.95
11-25752MMed	185.95
11-25753MLg	185.95
11-25754MXL	185.95
11-25755M2X	185.95



LADIES WORK PANTS (MODEL 6703)

Multi-purpose women's work trousers made of a 2-way stretch fabric. In addition, 4-way stretch panels provide optimal fit and enhanced freedom of movement, making the trousers a great choice for work that involves a lot of movement. Slim fit.

11-26000M28W x 31L (032)	147.95
11-26001M30W x 31L (034)	147.95
11-26002M31W x 31L (036)	147.95
11-26003M33W x 31L (038)	147.95
11-26004M34W x 31L (040)	147.95
11-26005M36W x 31L (042)	147.95
11-26006M37W x 31L (044)	147.95
11-26007M39W x 31L (046)	147.95
11-26008M41W x 31L (048)	147.95

Workwear



SNICKERS WEATHER FLEX GLOVES (MODEL 9319)

Insulated work gloves for precision work. Seamless gloves with brushed inside and smooth latex foam coating for high comfort and outstanding dexterity

16-2011MMed (9)	21.95
16-2012MLg (10)	21.95
16-2013MXL (11)	21.95



LOGO BRACES (MODEL 9064)

Logo braces built with an ergonomic design suitable for everyday use. The braces feature secure clips that provide all-day secure fastening of trousers as well as wide elastic straps for even distribution.

11-25809MOne Size	67.95
-----------	---------------	-------	-------



SNICKERS BALACLAVA (MODEL 9052)

The right protection when the cold gets tough. This seamless balaclava has been developed to offer warmth and weather protection when used under a hard hat. Soft, great comfort while light and thin for a great fit.

11-25804MSm/Med	58.95
11-25805MLg/XL	58.95



SNICKERS FLEX DUTY GLOVES (MODEL 9305)

Durable and breathable all-round work gloves. Seamless glove with high fingertip feeling for full control. Palm coated with a Nitrile foam for a secure grip.

16-2000MSm (8)	7.95
16-2001MMed (9)	7.95
16-2002MLg (10)	7.95
16-2003MXL (11)	7.95
16-2004M2X (12)	7.95



NEW



HELLY HANSEN BERG JACKET

Insulation: 100% Polyester, 160 g/m2 in body, 120 g/m2 in sleeves. Lining: 100% Nylon. Reflective details. Detachable hood with draw cord and velcro adjustment. Inner pocket with velcro closure. Two chest pockets with zippers. Two pockets at front with zippers. Draw cord adjustment at hem with button-up option for safety. Extended back. Velcro adjustment at cuffs. Storm flap with zipper and velcro closure. Chin guard. **Model 76201**

HELLY HANSEN BERG PANT

100% Polyester, 197 g/m2. Insulation: 100% polyester - 120 g/m2. Brushed polyester inside back. Button closure at waist. Fly with zip. Two pockets at front with zippers. Broad belt tunnel at back for extra strength and stability. Belt loops with click on function for additional accessories. Elastic at waist. Knee pad pockets inside. **Detachable back piece with elastic suspenders.** Boot zippers with storm flap and velcro closure. Button closure and elastic at hem of leg. Elastic bands under the feet. **Model 76400**

Berg Jacket - Model 76201

11-2236M.....Sm	11-2240M2X
11-2237M.....Med	11-2241M3X
11-2238MLg	11-2242M4X
11-2239MXL	

Berg Pants - Model 76400

11-2338M.....Sm	11-2342M2X
11-2339M.....Med	11-2343M3X
11-2340MLg	11-2344M4X
11-2341MXL	

All Sizes Berg Jackets \$169.95

All Sizes Berg Pants \$169.95



HELLY HANSEN KENSINGTON BEANIE

When comfort meets style -The Kensington wool beanie is 100% wool and will keep your head and ears warm on the coldest of days.

11-2616MGrey.....	46.95
11-2617MBlack.....	46.95

HELLY HANSEN OXFORD INSULATED JACKET

The Oxford winter jacket will keep you warm and comfortable through the cold winter. The fabric combinations ensure durability while the fit gives you movement and ability to get the job done. Critically taped. No shoulder seams. Articulated sleeves. Extended back for max comfort. Chin guard. Inner pocket. Cuffs with velcro adjustment. Draw cord adjustment at hood. Draw cord adjustment at hem.

Model 73290-990 (Black)

HELLY HANSEN OXFORD LINED CONSTRUCTION PANT

Possibility to increase leg length by 5cm. Articulated knees for optimal mobility. Knee Pad pockets accessible from the inside. Knee Pad position can be adjusted by 5 cm for optimal mobility. 2-way stretch fabric. Hanging pockets with double lined bottom and nylon webbing for durability. Broad center back belt loop for extra stability and strength. Gusset in crotch for freedom of movement. Plastic covered metal buttons. Thigh pocket with fastener closure. ID card loop. Ruler pocket. Reinforcement fabric at knee and bottom hem.

Oxford Insulated Jacket - Model 73290

11-2452MXS	11-2456MXL
11-2453M.....Sm	11-2457M2X
11-2454M.....Med	11-2458M3X
11-2455MLg	11-2459M4X

All Sizes Oxford Insulated Jackets \$234.95

Oxford Lined Pants - Model 77489

11-2816M30	11-2820M38
11-2817M32	11-2821M40
11-2818M34	11-2822M42
11-2819M36	11-2823M44

All Sizes Oxford Lined Pants \$168.95



NEW



NEW



HELLY HANSEN MANCHESTER FLEECE

The Manchester Zip In Fleece Jacket works great as stand alone warmth with its soft fleece fabric but doubles as an insulator when zipped into the Manchester Shell Jacket.

Model 72096 (Black)

11-2488MXS104.95
11-2489MSm104.95
11-2490MMed104.95
11-2491MLg104.95
11-2492MXL104.95
11-2493M2X104.95
11-2494M3X104.95
11-2495M4X104.95

NEW



HELLY HANSEN OXFORD LINED JACKET

No shoulder seams. Pile fleece lining. YKK front zipper with chin protector. Full inner front placket. Chest and hand pockets with zipper. Inner chest pocket. Embellishment zipper. Articulated sleeves for optimal mobility. Articulated cuffs. Extended back for improved comfort. Reflective details.

Model 77041 (Black)

11-2808MSm205.95
11-2809MMed205.95
11-2810MLg205.95
11-2811MXL205.95
11-2812M2X205.95
11-2813M3X205.95
11-2814M4X205.95

NEW



HELLY HANSEN LADIES LUNA SOFTSHELL JACKET

Softshell fabric with membrane & DWR. No shoulder seams. High collar for comfort. Brushed fleece inside collar. Articulated sleeves for optimal mobility. Adjustable hem with elastic drawcord inside hand pocket. Extended back for improved comfort.

Ladies Luna Softshell Jacket - Model 74240 (Black)

11-2763MXS149.95
11-2764MSm149.95
11-2765MMed149.95
11-2766MLg149.95
11-2767MXL149.95
11-2768M2X149.95

NEW



HELLY HANSEN HOODED OXFORD SOFTSHELL

Softshell fabrics with membrane and DWR. No shoulder seams. Detachable hood. Adjustable hood with drawcord and fastener. Brushed polyester inside collar. Articulated sleeves for optimal mobility. Adjustable cuffs. Adjustable hem with drawcord inside hand pocket. Extended back for improved comfort. Reflective details. Model 74290 (Black)

11-2462MSm179.95
11-2463MMed179.95
11-2464MLg179.95
11-2465MXL179.95
11-2466M2X179.95
11-2467M3X179.95
11-2468M4X179.95

NEW



HELLY HANSEN KENSINGTON SOFTSHELL JACKET

The Kensington Softshell Jacket is an excellent choice for the tradesmen who values ease and practicality. The high collar has a brushed fleece interior and the back hem is extended for improved comfort. The jacket also features multiple YKK zipper pockets and a chest pocket with cord hole for headphones that alleviates any unnecessary tangling. Model 74231 (Black)

11-2608MSm149.95
11-2609MMed149.95
11-2610MLg149.95
11-2611MXL149.95
11-2612M2X149.95
11-2613M3X149.95
11-2614M4X149.95

NEW



HELLY HANSEN LADIES MANCHESTER SERVICE PANTS

2-way mechanical stretch fabric. Gusset in crotch for freedom of movement. Plastic covered metal buttons. Thigh pocket with fastener closure. ID card loop. Possibility to increase leg length by 5 cm. Reflective details. Model 77532 (Black)

11-2778M4 x 30	11-2786M4 x 32
11-2779M6 x 30	11-2787M6 x 32
11-2780M8 x 30	11-2788M8 x 32
11-2781M10 x 30	11-2789M10 x 32
11-2782M12 x 30	11-2690M12 x 32
11-2783M14 x 30	11-2691M14 x 32
11-2784M16 x 30	11-2692M16 x 32
11-2785M18 x 30	11-2693M18 x 32

All Sizes Helly Hansen Ladies Service Pants

\$94.95

Workwear

CLOTHING



HELLY HANSEN OXFORD CONSTRUCTION PANT

The Oxford Construction pant provides durability without compromising on comfort. 2-way stretch in critical areas makes sure the wearer has freedom of movement while the reinforced fabric at the knees and bottom hem protects the wearer and the pants from daily wear, A perfect choice for the working tradesmen.

Black		Navy	
11-2619M30 x 30	11-2630M36 x 32	11-2643M30 x 30	11-2654M36 x 32
11-2620M32 x 30	11-2631M38 x 32	11-2644M32 x 30	11-2655M38 x 32
11-2621M34 x 30	11-2632M40 x 32	11-2645M34 x 30	11-2656M40 x 32
11-2622M36 x 30	11-2633M42 x 32	11-2646M36 x 30	11-2657M42 x 32
11-2623M38 x 30	11-2634M44 x 32	11-2647M38 x 30	11-2658M44 x 32
11-2627M30 x 32	11-2636M32 x 34	11-2651M30 x 32	11-2660M32 x 34
11-2628M32 x 32	11-2637M34 x 34	11-2652M32 x 32	11-2661M34 x 34
11-2629M34 x 32	11-2638M36 x 34	11-2653M34 x 32	11-2662M36 x 34

All Sizes Helly Hansen Oxford Construction Pants \$139.95

HELLY HANSEN OXFORD BIB PANTS

With its elastic suspenders & 4-way stretch in the sides, the Oxford Bib is the perfect choice when both comfort & durability is needed.

Black	
11-2723M30 x 32	11-2727M38 x 32
11-2724M32 x 32	11-2728M40 x 32
11-2725M34 x 32	11-2729M42 x 32
11-2726M36 x 32	11-2730M44 x 32

Navy	
11-2747M30 x 32	11-2751M38 x 32
11-2748M32 x 32	11-2752M40 x 32
11-2749M34 x 32	11-2753M42 x 32
11-2750M36 x 32	11-2754M44 x 32

All Sizes Helly Hansen Oxford Bib \$154.95



HELLY HANSEN OXFORD WORK PANT

The Oxford Work pant provides durability and great comfort by having 2-way stretch in critical areas to makes sure the wearer has freedom of movement. With reinforced fabric at the knees and bottom hem protects the wearer and the pants from daily wear and tear.

Black		Navy	
11-2667M30 x 30	11-2678M36 x 32	11-2691M30 x 30	11-2702M36 x 32
11-2668M32 x 30	11-2679M38 x 32	11-2692M32 x 30	11-2703M38 x 32
11-2669M34 x 30	11-2680M40 x 32	11-2693M34 x 30	11-2704M40 x 32
11-2670M36 x 30	11-2681M42 x 32	11-2694M36 x 30	11-2705M42 x 32
11-2671M38 x 30	11-2682M44 x 32	11-2695M38 x 30	11-2706M44 x 32
11-2675M30 x 32	11-2684M32 x 34	11-2699M30 x 32	11-2708M32 x 34
11-2676M32 x 32	11-2685M34 x 34	11-2700M32 x 32	11-2709M34 x 34
11-2677M34 x 32	11-2686M36 x 34	11-2701M34 x 32	11-2710M36 x 34

All Sizes Helly Hansen Oxford Work Pants \$130.95



HELLY HANSEN CHELSEA KNEEPAD

Conforms to EN 14404 Knee protection. 240mm x 147mm x 20mm. Ergonomic shape. Lightweight. Use with Construction Pants, Bib Pants, and Work Pants.
11-2618MOne Size19.95/pair



NEW



Workwear

TIMBERLAND PRO IRONHIDE JACKET

With zoned insulation to help keep you warm where you need it, our Ironhide hooded jacket also features RainRepel water-resistant technology for protection in all kinds of weather. Plus, it's made with 68% cotton grown by farmers trained in efficient water management, healthy soil practices, natural habitat conservation, and respect for worker rights and well-being.

Brown

11-20064MSm199.95
11-20065MMed199.95
11-20066MLg199.95
11-20067MXL199.95
11-20068M2X199.95
11-20069M3X199.95

Black

11-3275MSm199.95
11-3276MMed199.95
11-3277MLg199.95
11-3278MXL199.95
11-3279M2X199.95
11-3280M3X199.95

TIMBERLAND PRO IRONHIDE WORK PANTS

The Timberland PRO® Ironhide work pants are reinforced, built for a full range of motion, accommodate plenty of tools and are designed to hold up to pretty much everything the job site can throw at you. Knee pads sold separately.

Black

11-3148M30 x 32	11-3158M30 x 34
11-3149M31 x 32	11-3160M32 x 34
11-3150M32 x 32	11-3161M34 x 34
11-3151M34 x 32	11-3162M36 x 34
11-3152M36 x 32	11-3163M38 x 34
11-3153M38 x 32		
11-3154M40 x 32		
11-3155M42 x 32		

Brown

11-3168M30 x 32	11-3178M30 x 34
11-3169M31 x 32	11-3180M32 x 34
11-3170M32 x 32	11-3181M34 x 34
11-3171M34 x 32	11-3182M36 x 34
11-3172M36 x 32	11-3183M38 x 34
11-3173M38 x 32		
11-3174M40 x 32		
11-3175M42 x 32		

All Sizes Ironhide Work Pants \$139.95

NEW



TIMBERLAND PRO IRONHIDE BIB OVERALLS

Multiple pockets help ensure plenty of storage in bib overalls made with Lycra Tough Max Technology for the durable performance you need on the job.

Brown

11-20096MSm169.95
11-20097MMed169.95
11-20098MLg169.95
11-20099MXL169.95
11-20100M2X169.95
11-20101M3X169.95

Tall Sizes

11-20104MMed Tall169.95
11-20105MLg Tall169.95
11-20106MXL Tall169.95
11-20107M2X Tall169.95
11-20108M3X Tall169.95

Black

11-20076MSm169.95
11-20077MMed169.95
11-20078MLg169.95
11-20079MXL169.95
11-20080M2X169.95
11-20081M3X169.95

Tall Sizes

11-20084MMed Tall169.95
11-20085MLg Tall169.95
11-20086MXL Tall169.95
11-20087M2X Tall169.95
11-20088M3X Tall169.95

NEW



TIMBERLAND PRO ANTI FATIGUE KNEE PADS

Get down to business: Our anti-fatigue knee pad inserts are designed to protect your knees from hard surfaces with dual-density cushioning foam. After all, you're not working in a pillow factory.

11-3073MOne Size34.95
----------	---------------	------------

Prices are subject to change. Check our website for up to date prices. www.mercersmarine.com

CLOTHING

NEW



NEW



TIMBERLAND PRO GRITMAN JACKET

Our Gritman fleece-lined canvas jackets effortlessly take on the job site and the elements, with high-pile fleece lining, plenty of pockets to keep you organized, extra mobility features, and responsibly sourced cotton.

Brown

11-20057M.....Sm	159.95
11-20058M.....Med	159.95
11-20059M.....Lg.....	159.95
11-20060M.....XL.....	159.95
11-20061M.....2X.....	159.95
11-20062M.....3X.....	159.95
11-20063M.....4X.....	159.95

Black

11-20050M.....Sm	159.95
11-20051M.....Med	159.95
11-20052M.....Lg.....	159.95
11-20053M.....XL.....	159.95
11-20054M.....2X.....	159.95
11-20055M.....3X.....	159.95
11-20056M.....4X.....	159.95

TIMBERLAND PRO FROSTWALL JACKET

Designed for maximum flexibility, this men's jacket stands strong against bad weather with water-repellent fabrication and warm, eco-conscious Thermolite® Ecomade insulation for superior warmth with minimal weight.

11-3465M.....Sm	159.95
11-3466M.....Med	159.95
11-3467M.....Lg.....	159.95
11-3468M.....XL.....	159.95
11-3469M.....2X.....	159.95
11-3470M.....3X.....	159.95

NEW



TIMBERLAND PRO GRITMAN BIB OVERALLS - INSULATED

These rugged overalls are designed for cool weather, with lightweight, durable insulation that provides superior warmth and breathability for all your activities. Pockets and a hammer loop give you plenty of storage, while zipped leg openings offer the flexibility you need on the job.

Brown

11-20114M.....Sm	179.95
11-20115M.....Med	179.95
11-20116M.....Lg.....	179.95
11-20117M.....XL.....	179.95
11-20118M.....2X.....	179.95
11-20119M.....3X.....	179.95

Grey

11-20132M.....Sm	179.95
11-20133M.....Med	179.95
11-20134M.....Lg.....	179.95
11-20135M.....XL.....	179.95
11-20136M.....2X.....	179.95
11-20137M.....3X.....	179.95

Black

11-20196M.....Sm	179.95
11-20197M.....Med	179.95
11-20198M.....Lg.....	179.95
11-20199M.....XL.....	179.95
11-20200M.....2X.....	179.95
11-20201M.....3X.....	179.95



NEW



TIMBERLAND PRO IRONHIDE SOFTSHELL JACKET

Thermofleece with brushed interior for comfort and treated with RainRepel technology to shed precipitation. Raglan sleeves for improved range of motion. Secure chest pocket made from durable ripstop material. Elastic cuffs and bottom hem seal out the cold. Adjustable hood for snug fit. Two side pockets.

11-3471M.....	Sm	159.95
11-3472M.....	Med	159.95
11-3473M.....	Lg	159.95
11-3474M.....	XL	159.95
11-3475M.....	2X	159.95
11-3476M.....	3X.....	159.95

NEW



TIMBERLAND PRO GRITMAN VEST

Our Gritman lined canvas vests are designed to keep your core warm and give you the full range of motion you need when you're out working on chilly days.

11-3477M.....	Sm	109.95
11-3478M.....	Med	109.95
11-3479M.....	Lg	109.95
11-3480M.....	XL	109.95
11-3481M.....	2X	109.95
11-3482M.....	3X.....	109.95
11-3483M.....	4X.....	109.95

NEW



TIMBERLAND PRO TRAILWIND FLEECE JACKET

When the weather and work conditions are unpredictable, layer on our midweight thermofleece jacket. Maximum mobility and RainRepel to resist moisture penetration. Ripstop overlays around your neck and shoulders and the back of the sleeves provide extra durability, while the collar has a soft, comfortable edge between your neck and the zipper to prevent irritation from rubbing. Two front handwarmer pockets and a secure zippered inner pocket.

11-20178M.....	Sm	149.95
11-20179M.....	Med	149.95
11-20180M.....	Lg	149.95
11-20181M.....	XL	149.95
11-20182M.....	2X.....	149.95
11-20183M.....	3X.....	149.95

NEW



TIMBERLAND PRO HOOD HONCHO ZIP HOODIE

Original fit. Mid-weight cotton/polyester blend fleece. Adjustable three-piece hood and drawstring closure. Two front pouch pockets with hidden cell phone insert. Screen-printed sleeve logo styles. Set in sleeves. Heavy-gauge metal zipper. Ribbed knit cuff and bottom.

Black		
11-3228M.....	Sm	99.95
11-3229M.....	Med	99.95
11-3230M.....	Lg	99.95
11-3231M.....	XL	99.95
11-3232M.....	2X.....	99.95
11-3233M.....	3X.....	99.95
11-3234M.....	4X.....	99.95

Charcoal		
11-20022M.....	Sm	99.95
11-20023M.....	Med	99.95
11-20024M.....	Lg	99.95
11-20025M.....	XL	99.95
11-20026M.....	2X.....	99.95
11-20027M.....	3X.....	99.95
11-20028M.....	4X.....	99.95



TIMBERLAND PRO ESSENTIAL WATCH CAP

Cozy watch caps bring a new layer of warmth to the job site. And don't feel like you only have to wear them to work; these winter hats take on everyday life with rugged style.

11-3398M.....	Charcoal	19.95
11-3399M.....	Black	19.95
11-3400M.....	Navy	19.95
11-3401M.....	Orange	19.95



TIMBERLAND PRO LADIES GRITMAN INSULATED BIB OVERALLS

Original fit. Rugged cotton canvas breaks in easy and wears hard. Lightly insulated for year-round comfort. Stretch straps with classic metal closures and adjusters. Knee overlay with drain holes. Timberland PRO orange detail. Ergonomically shaped back panel for enhanced fit and mobility. Shank button closure on sides. Zippered leg opening for easy-on over boots.

Brown		
11-20220MXS179.95
11-20221MSm179.95
11-20222MMed179.95
11-20223MLg179.95
11-20224MXL179.95
11-20225M2X179.95

Black		
11-20208MXS179.95
11-20209MSm179.95
11-20210MMed179.95
11-20211MLg179.95
11-20212MXL179.95
11-20213M2X179.95

TIMBERLAND PRO HOOD HONCHO PULLOVER HOODIE

Pull on this hoodie when you need a comfortable sweatshirt that works as hard as you do. Its mid-weight, water-repellent fleece fabric features a blend of cotton that's grown and farmed responsibly with polyester added for stretch and shape retention. The 3-piece hood design stays in place better than traditional hoods and the raglan sleeves give you more freedom of movement when worn over additional layers. There's even a hidden pocket to secure your cell phone.

Black		
11-3456MSm84.95
11-3457MMed84.95
11-3458MLg84.95
11-3459MXL84.95
11-3460M2X84.95

Navy		
11-3207MSm84.95
11-3208MMed84.95
11-3209MLg84.95
11-3210MXL84.95
11-3211M2X84.95



TIMBERLAND PRO LADIES GRITMAN BIB OVERALLS

Original Fit. Rugged cotton canvas breaks in easy and wears hard. Anatomically shaped back panel for improved fit. Stretch straps with classic metal closures and adjusters. Knee overlay with drain holes. Timberland PRO orange details. Shank button closure on sides. Zippered leg opening for easy-on over boots.

Brown		
11-20244MXS159.95
11-20245MSm159.95
11-20246MMed159.95
11-20247MLg159.95
11-20248MXL159.95
11-20249M2X159.95

Black		
11-20232MXS159.95
11-20233MSm159.95
11-20234MMed159.95
11-20235MLg159.95
11-20236MXL159.95
11-20237M2X159.95



BERNE
NEW



BERNE HERITAGE BOMBER

10 oz., heavy-duty cotton duck. Heavyweight quilt-lined taffeta liner. Water repellent finish. Triple-needle stitched main seam. Heavy-duty brass zipper. Three-piece insulated hood with drawstring. Pleated action back. Pleated elbows. Two front patch pockets. Three inside pockets. **Model - HJ51BD**

11-29001M.....	Sm	104.95
11-29002M.....	Med	104.95
11-29003M.....	Lg.....	104.95
11-29004M.....	XL.....	104.95
11-29005M.....	2X.....	104.95
11-29006M.....	3X.....	112.95
11-29007M.....	4X.....	112.95
11-29008M.....	5X.....	123.50

BERNE
NEW



BERNE HERITAGE COAT

10 oz., heavy-duty cotton duck. Heavyweight quilt-lined taffeta liner. Water repellent finish. Triple-needle stitched main seam. Heavy-duty brass zipper with storm flap. Collar snaps for optional hood. Two chest pockets with hook/loop closures. Pleated elbows and action back. Knit cuffs and waistband.

Brown - CH416BD

11-29038M.....	Sm	114.95
11-29039M.....	Med	114.95
11-29040M.....	Lg.....	114.95
11-29041M.....	XL.....	114.95
11-29042M.....	2X.....	114.95
11-29043M.....	3X.....	125.95
11-29044M.....	4X.....	125.95
11-29045M.....	5X.....	136.95



Black - CH416BK

11-29060M.....	Sm	114.95
11-29061M.....	Med	114.95
11-29062M.....	Lg.....	114.95
11-29063M.....	XL.....	114.95
11-29064M.....	2X.....	114.95
11-29065M.....	3X.....	125.95
11-29066M.....	4X.....	125.95
11-29067M.....	5X.....	136.95

Workwear

BERNE
NEW



BERNE CHILDRENS/YOUTH UNLINED OVERALLS

10 oz. 100% cotton sanded duck. Relaxed fit and adjustable bib straps for comfortable wear. Brass fly zipper and triple-needle stitched main seams keep up with work or play. Multi-pocket bib top with snap closure easily store essentials. **Model BB13BD**

11-29289M.....	4.....	59.95
11-29290M.....	5.....	59.95
11-29291M.....	6.....	59.95
11-29292M.....	7.....	59.95
11-29293M.....	8.....	59.95
11-29294M.....	10.....	59.95
11-29295M.....	12.....	59.95
11-29296M.....	14.....	59.95
11-29297M.....	16.....	59.95
11-29298M.....	18.....	59.95

BERNE
NEW



BERNE HERITAGE INSULATED BIB OVERALLS

10 oz. shell. 100% cotton duck Lining: Medium-weight insulation quilted to taffeta. Water-repellent finish and insulated high back keep you warm and dry. Double inside chest pockets, two swing pockets, two reinforced back pockets - left with brass zipper - side utility pockets and hammer loop all provide sturdy storage. Four-needle stitched waistband with elastic inserts, adjustable elasticized bib straps and leg snaps allow for custom fit. Triple-needle stitched main seams, reinforced knees and heavy-duty nylon leg hem stand up to the toughest jobs. Heavy-duty brass two-way front zipper and brass leg zipper with snap closure at hand opening for lasting wear.

Brown - B415BD

11-29079M.....	Sm	129.95
11-29080M.....	Med	129.95
11-29081M.....	Lg.....	129.95
11-29082M.....	XL.....	129.95
11-29083M.....	2X.....	129.95
11-29084M.....	3X.....	141.95
11-29085M.....	4X.....	141.95
11-29086M.....	5X.....	154.50

Black - B415BK

11-29106M.....	Sm	129.95
11-29107M.....	Med	129.95
11-29108M.....	Lg.....	129.95
11-29109M.....	XL.....	129.95
11-29110M.....	2X.....	129.95
11-29111M.....	3X.....	141.95
11-29112M.....	4X.....	141.95
11-29113M.....	5X.....	154.50

CLOTHING

Prices are subject to change. Check our website for up to date prices. www.mercersmarine.com



BERNE HERITAGE UNLINED BIB OVERALLS

Heavy-duty 10 oz cotton duck. Unlined. Generous cut for maximum comfort. Knee-length zipper. Water-repellent finish. Triple-needle stitched seams. Brass rivets at front stress points. Side utility pockets. Hammer loop. Adjustable elasticized straps. Reinforced knees.

Brown - B1067BD

11-29140M.....	32 x 32	74.95
11-29141M.....	34 x 32	74.95
11-29142M.....	36 x 32	74.95
11-29143M.....	38 x 32	74.95
11-29144M.....	40 x 32	74.95
11-29145M.....	42 x 32	74.95
11-29146M.....	44 x 32	80.95
11-29147M.....	46 x 32	80.95
11-29148M.....	48 x 32	80.95
11-29149M.....	50 x 32	80.95
11-29150M.....	52 x 32	80.95
11-29151M.....	54 x 32	80.95

Black - B1067BK

11-29187M.....	32 x 32	74.95
11-29188M.....	34 x 32	74.95
11-29189M.....	36 x 32	74.95
11-29190M.....	38 x 32	74.95
11-29191M.....	40 x 32	74.95
11-29192M.....	42 x 32	74.95
11-29193M.....	44 x 32	80.95
11-29194M.....	46 x 32	80.95
11-29195M.....	48 x 32	80.95
11-29196M.....	50 x 32	80.95
11-29197M.....	52 x 32	80.95
11-29198M.....	54 x 32	80.95

BERNE LADIES FLEX SOTSTONE DUCK UNLINED BIB OVERALLS

Fabric:7.8 oz. 98% cotton 2% spandex sanded duck. Washed, stretch fabric for added mobility and comfort. Adjustable waist and elasticized bib straps for optimal fit. Reinforced knees and back leg hem plus triple-needle stitched main seams. Multi-tool bib pocket with zipper closure, side utility pockets and tape measure opening keep tools handy.

Titanium - WB922T

11-29249M.....	Sm	89.95
11-29250M.....	Med	89.95
11-29251M.....	Lg	89.95
11-29252M.....	XL	89.95
11-29253M.....	2X	89.95
11-29254M.....	3X	98.50



KIDS



BERNE YOUTH SOFTSTONE JACKET

Shell: 10 oz. 100% cotton sanded duck Lining: Heavyweight insulation quilted to polyester taffeta. Water-repellent finish, three-piece lined hood with elastic inserts, rib-knit cuffs and waistband protect from the weather. Pleated action back allows for improved mobility. Brass front zipper and triple-needle stitched main seams hold up to the day's chores. Three inside chest pockets and large front pockets for storage.

Black - BHJ61BK

11-29279M.....	XS	76.95
11-29280M.....	Sm	76.95
11-29281M.....	Med	76.95
11-29282M.....	Lg	76.95
11-29283M.....	XL	76.95

Plum - BHJ61PL

11-29284M.....	XS	76.95
11-29285M.....	Sm	76.95
11-29286M.....	Med	76.95
11-29287M.....	Lg	76.95
11-29288M.....	XL	76.95

SHOP 24/7 FROM THE COMFORT OF YOUR OWN HOME

- Up to date Pricing
- New Products
- Stock Status
- Additional product info
- And more



www.mercersmarine.com





HELLY HANSEN WEYBURN PARKA - 76313

The Weyburn Parka is designed for the coldest winter work outside. The beaver nylon exterior is hard wearing, while the thermal pile lining provides great insulation and warmth no matter the weather. Since this parka is designed for below freezing conditions, the water repellent exterior will be perfect to retain movement and not freeze up. The fit can also be adjusted via an elasticated waist and inner wind belt.

HELLY HANSEN THOMPSON PANT - 76512

The Thompson Bib is designed for the coldest winter work outside, and pairs perfectly with the Weyburn Parka for a full outerwear kit in cold conditions. The beaver nylon exterior is hard wearing, while the thermal pile lining provides great insulation and warmth no matter the weather. Since this bib is designed for below freezing conditions, the water repellent exterior will be perfect to retain movement and not freeze up. PU-coated nylon reinforcements in strategic areas help prolong life in high wear areas, while the bib also features a two-way zipper at the front with a storm flap, and adjustable elastic suspenders and elastic at the back waist.

Weyburn Jacket - Model 76313

11-2045K.....XS	11-2050K.....2X
11-2046KSm	11-2051K.....3X
11-2047KMed	11-2052K.....4X
11-2048K.....Lg	11-2053K.....5X
11-2049K.....XL	

All Sizes Weyburn Jackets \$359.95

Thompson Bib Pants - Model 76512

11-2027K.....XS	11-2032K.....2X
11-2028KSm	11-2033K.....3X
11-2029KMed	11-2034K.....4X
11-2030K.....Lg	11-2035K.....5X
11-2031K.....XL	

All Sizes Thompson Pants \$324.95

HELLY HANSEN ALNA POLAR JACKET - 71316

With a strong design and packed with features; Alna Polar Parka is the ultimate winter parka. Using Helly Tech Performance fabric & recycled blowable insulation, we guarantee that you will stay warm during colder days. With additional body mapped pile insulation you get a soft and comfortable warmth next to your upper body.

HELLY HANSEN ALNA POLAR BIB PANTS - 71516

With Helly Tech Performance fabric, critically taped construction & recycled blowable insulation, we guarantee that you will stay warm during the colder days. With additional pile insulation you get an extra soft and comfortable warmth next to your upper body. This bib has a tailored and articulated fit, which increases the comfort and optimal freedom of movement.

Alna Jacket - Model 71316

11-2862M.....Sm	11-2866M2X
11-2863M.....Med	11-2867M3X
11-2864MLg	11-2868M4X
11-2865MXL	11-2869M5X

All Sizes Alna Jackets \$489.95

Alna Bib Pants - Model 71516

11-2871M.....Sm	11-2875M2X
11-2872M.....Med	11-2876M3X
11-2873MLg	11-2877M4X
11-2874MXL	11-2878M5X

All Sizes Alna Bib Pants \$329.95



NEW



HELLY HANSEN HERITAGE PILE HOODIE

100% Recycled fabric. Adjustable hood with drawcord. YKK front zipper. Elastic cuffs with thumbholes.

11-2825M	XS	154.95
11-2826M	Sm	154.95
11-2827M	Med	154.95
11-2828M	Lg	154.95
11-2829M	XL	154.95
11-2830M	2X	154.95
11-2831M	3X	154.95
11-2832M	4X	154.95

NEW



HELLY HANSEN HERITAGE PILE JACKET

100% Recycled fabric. YKK front zipper. Elastic cuffs with thumbholes.

11-2834M	XS	135.95
11-2835M	Sm	135.95
11-2836M	Med	135.95
11-2837M	Lg	135.95
11-2838M	XL	135.95
11-2839M	2X	135.95
11-2840M	3X	135.95
11-2841M	4X	135.95

NEW



HELLY HANSEN HERITAGE PILE PANTS

100% Recycled fabric. Elastic waist. Ribbed bottom hem.

11-2843M	XS	119.95
11-2844M	Sm	119.95
11-2845M	Med	119.95
11-2846M	Lg	119.95
11-2847M	XL	119.95
11-2848M	2X	119.95
11-2849M	3X	119.95
11-2850M	4X	119.95



HELLY HANSEN GLOVE LINER

Lightweight fabric. Knitted Glove Liner. Ribbed cuff Glove Liner - Model 79692

12-1605M	14.95/pr.
----------	-----------



HELLY HANSEN CHELSEA SOCKS

With Lifa fibers added in the heel & toe, these technical socks constantly work to keep the foot dry and at a comfortable temperature in cold weather.

11-2802M	36-38	27.95/pr.
11-2803M	39-42	27.95/pr.
11-2804M	43-46	27.95/pr.



HELLY HANSEN OXFORD SOCKS

This full terry leg ergonomic sock has great durability and helps keep you warm and comfortable.

11-2805M	36-38	23.95/pr.
11-2806M	39-42	23.95/pr.
11-2807M	43-46	23.95/pr.





Workwear

HELLY HANSEN LIFA MAX CREWNECK & PANT

Helly Hansen is proud to introduce the all new Lifa® Max to our assortment. 100% Lifa® ensures sweat is transported away from your skin while the dual layer gives you the warmth. This is our warmest base layer and is built for low to medium activity.

Lifa Max Crewneck - Model 75108 (Navy)

11-2545MXS84.95
11-2546MSm84.95
11-2547MMed84.95
11-2548MLg84.95
11-2549MXL84.95
11-2550M2X84.95
11-2551M3X84.95
11-2552M4X84.95
11-2553M5X84.95

Lifa Max Pant - Model 75508 (Navy)

11-2564MXS84.95
11-2565MSm84.95
11-2566MMed84.95
11-2567MLg84.95
11-2568MXL84.95
11-2569M2X84.95
11-2570M3X84.95
11-2571M4X84.95
11-2572M5X84.95

HELLY HANSEN LIFA MAX TOQUE

Lifa Stay Warm Technology. Lifa Max. Double main fabric
 Model 79708-590 (NAVY)
 11-2584M.....One Size27.95



HELLY HANSEN LIFA MAX NECK GAITER

Lifa Stay Warm Technology. Lifa Max. Double main fabric
 Model 79709-590 (NAVY)
 11-2586M.....One Size25.95
 Model 79709-990 (BLACK)
 11-2587M.....One Size25.95

HELLY HANSEN LIFA MAX BALACLAVA

Lifa Stay Warm Technology. Lifa Max. Double main fabric
 Model 79710-590 (NAVY)
 11-2582M.....One Size32.95

HELLY HANSEN HERITAGE PILE ONE PIECE

2-way YKK zipper at front. Elastic cuffs with thumbholes. Elastic waist. Ribbed bottom hem.
 11-2852MXS 189.95
 11-2853MSm 189.95
 11-2854MMed 189.95
 11-2855MLg 189.95
 11-2856MXL 189.95
 11-2857M2X 189.95
 11-2858M3X 189.95
 11-2859M4X 189.95

CLOTHING



HARD HAT LINER 70-WH-25

Polyamide fabric. Synthetic fur lining. One Size

12-6907M.....One Size38.95



HARD HAT LINER 70-WH-15

100% cotton. Polyester lining.

12-6908M.....Med29.95
 12-6909M.....Lg29.95
 12-6910M.....XL29.95
 12-6911M2X29.95



HARD HAT LINER 70-WH-10

100% cotton. Boa lining.

12-6912M.....Med22.95
 12-6913M.....Lg22.95
 12-6914M.....XL22.95
 12-6915M2X22.95



HARD HAT LINER 70-WH-03

100% cotton. Polyester lining.

12-6916M.....Med24.95
 12-6917M.....Lg24.95
 12-6918M.....XL24.95
 12-6919M2X24.95



MISTY MOUNTAIN UNDERWEAR

190 Micra Fleece light weight underwear is extremely comfortable, super soft, and has a cozy feel. Also wicks moisture away from skin.

CREW-NECK TOP

Mens (Black)
 12-121P.....Sm26.95
 12-122P.....Med26.95
 12-123P.....Lg26.95
 12-124P.....XL26.95
 12-125P2X26.95
Ladies (Black)
 12-126P.....Sm26.95
 12-127P.....Med26.95
 12-128P.....Lg26.95
 12-129P.....XL26.95

FLEECE BOTTOMS

Mens (Black)
 12-130P.....Sm26.95
 12-131P.....Med26.95
 12-132P.....Lg26.95
 12-133P.....XL26.95
 12-134P2X26.95
Ladies (Black)
 12-135P.....Sm26.95
 12-136P.....Med26.95
 12-137P.....Lg26.95
 12-138P.....XL26.95



HARD HAT LINER 70-WH-14-TH

100% cotton. Polyester lining. Thinsulate C40 insulation.

12-6920M.....Med34.95
 12-6921M.....Lg34.95
 12-6922M.....XL34.95
 12-6923M2X34.95





HI-VIS QUILTED WINTER COVERALLS (633TCSA)

Breathable, wind and waterproof. High Vis, Lined Coverall with front zip flap. 4" reflective striping. Chest pockets. Mobile phone pocket. Loop for hands free wiring. Storm pocket. Oblique pockets with zipper. Rear pockets. Double folding rule pocket. Knife holder. Adjustable cuffs. Knee pockets. Zipper on collar for attaching hood. Fleece in collar and cuffs. Elastic ankles. Zipper in legs. Quilted lining. Taped seams. Use knee pads 9001. CSA-Z96-09 Class 3 Level 2.

Red/Black		Yellow/Black	
11-8087K	XS	11-8095K	XS
11-8088K	Sm	11-8096K	Sm
11-8089K	Med	11-8097K	Med
11-8090K	Lg	11-8098K	Lg
11-8091K	XL	11-8099K	XL
11-8092K	2X	11-8100K	2X
11-8093K	3X	11-8101K	3X
11-8094K	4X	11-8102K	4X

HI-VIS QUILTED WINTER JACKET (533TCSA)

Breathable, wind and waterproof. High visibility, lined jacket with front zip flap. 4" reflective striping. Chest pockets with velcro on flaps. Front pockets with zipper. Storm pocket with zipper. Inside pocket. Inside mobile phone pocket. Detachable hood. Fleece in collar, cuffs and inside front pockets. Adjustable cuffs. Elastic drawstring in hemline. Lengthened back. Quilted lining. Taped seams. Piping in separation seams. CSA-Z96-09 Class 2 Level 2 when worn alone.

Red/Black		Yellow/Black	
11-8104K	Sm	11-8112K	Sm
11-8105K	Med	11-8113K	Med
11-8106K	Lg	11-8114K	Lg
11-8107K	XL	11-8115K	XL
11-8108K	2X	11-8116K	2X
11-8109K	3X	11-8117K	3X
11-8110K	4X	11-8118K	4X



HI-VIS QUILTED WINTER OVERALLS (833TCSA)

Breathable, wind and waterproof. High visibility. 4" reflective striping. Pocket on bib. Oblique pockets with through access. Large back pockets, right has flap with velcro. Double folding rule pocket. Knife holder. Large thigh pocket. Rounded knees with reinforcement in Duratex. Knee pockets. Adjustable at sides. Zipper in legs. Elastic ankles. Quilted lining. Taped seams. Use knee pads 9001. CSA-Z96-09 Class 3 Level 2 when worn with 533TCSA.

Red/Black		Yellow/Black	
11-8120K	Sm	11-8128K	Sm
11-8121K	Med	11-8129K	Med
11-8122K	Lg	11-8130K	Lg
11-8123K	XL	11-8131K	XL
11-8124K	2X	11-8132K	2X
11-8125K	3X	11-8133K	3X
11-8126K	4X	11-8134K	4X



INDUSTRIAL KNEE PADS

Upgraded material that protects the knee better and has longer durability. Equipped with text informing you that the kneepad shall be placed with cushion against the knee.

11-8151K	24.95/pair
----------	------------

NEW



LYNGSOE
WENAAS

LYNGSOE INSULATED COVERALL

Winter thermal coverall, Two-way zipper with stormflap, Multiply pockets with various functions, Removable hood, Zipper and inside storm flap at ankles, Elasticated waist adjustments, Sleeves and ankles with velcro adjustments, Reflective details, Cordura reinforcement on knees, Good comfort and lightweight

11-8163KXXS244.95
11-8164KXS244.95
11-8165KSm244.95
11-8166KMed244.95
11-8167KLg244.95
11-8168KXL244.95
11-8169K2X244.95
11-8170K3X244.95
11-8171K4X244.95
11-8172K5X244.95
11-8173K6X244.95
11-8174K7X244.95
11-8175K8X244.95



WENAAS

WENAAS CSA COVERALL

Material: 65% Polyester, 35% Cotton. Weight: 245 g/m² (8.64 oz.) 2 way front zipper. Elasticized waist. 2 chest pockets with flaps. 2 side pockets with access to under garments. 2 back pockets. Knee pockets. ID pocket on arm. Ratings: CSA Z96-09 Class 3 Level 2.

11-8143MSm139.95
11-8144MMed139.95
11-8145MLg139.95
11-8146MXL139.95
11-8147M2X139.95
11-8148M3X139.95
11-8149M4X139.95

NEW



WENAAS

WENAAS HI-VIS CSA THERMAL JACKET

Front zip flap. Chest pockets with velcro on flaps. Front pockets with zipper. Storm pocket with zipper. Inside pockets. Inside mobile phone pocket. Detachable hood. Fleece in collar and cuffs. Fleece in inside front pocket. Adjustable cuffs. Elastic drawstring in hemline. Lengthened back. Quilted lining. 4" reflective CSA Compliant taping on front and back of garment. Breathable Windproof waterproof with taped seams.

11-8211KXS264.95
11-8212KSm264.95
11-8213KMed264.95
11-8214KLg264.95
11-8215KXL264.95
11-8216K2X264.95
11-8217K3X264.95
11-8218K4X264.95

NEW

WENAAS



WENAAS HI-VIS CSA THERMAL BIB OVERALL

Breathable, wind and waterproof. Zip fly. Pocket on bib. Oblique pockets with through access. Large back pockets, right with velcro. Double folding rule pocket. Knife holder. Large thigh pocket. Rounded knee. Knee pockets in Polyamide. Adjustable at sides. Zipper in leg. Velcro ankles. Quilted lining. 4" reflective CSA Compliant taping on front and back of garment. Breathable Windproof waterproof with taped seams. Knee pads 11-8151 optional.

11-8220KXS249.95
11-8221KSm249.95
11-8222KMed249.95
11-8223KLg249.95
11-8224KXL249.95
11-8225K2X249.95
11-8226K3X249.95
11-8227K4X249.95

Want to receive e-mail updates from Mercer's Marine?
Subscribe at mercersmarine.com





WENAAS CSA FLAME RETARDANT COVERALL

Concealed two-way non-conductive front zipper. Concealed non-conductive buttons on sleeves and legs. CSA Z96-15 Compliant Class 3 Level 2. 4" two-tone FR reflective tape. Radio loop on left front shoulder. Two chest pockets with velcro closures. Two back pockets with velcro closure. ID pocket on sleeve. Internal knee pockets.

11-8177M.....	Sm	244.95
11-8178M.....	Med	244.95
11-8179M.....	Lg.....	244.95
11-8180M.....	XL	244.95
11-8181M	2X.....	244.95
11-8182M	3X.....	244.95
11-8183M	4X.....	244.95

LYNGSOE CSA FLAME RETARDANT JACKET

Detachable and adjustable hood. Helmet size hood. Chestpocket for ID-card. Hidden chestpocket. Two front pockets with velcro closing. Hidden zipper. Ventilation on the back. Button adjustments on the sleeves. Storm cuffs in the sleeves. Waterproof: 20,000mm.

Orange

11-8186K.....	Sm	186.95
11-8187K.....	Med	186.95
11-8188K.....	Lg.....	186.95
11-8189K.....	XL.....	186.95
11-8190K.....	2X.....	186.95
11-8191K.....	3X.....	186.95
11-8192K.....	4X.....	186.95

LYNGSOE CSA FLAME RETARDANT BIB PANTS

Elastic braces with buckle for adjustment. Adjustable at ankles. Reinforced tool pocket on the right thigh. Waterproof: 20,000mm.

Orange

11-8195K.....	Sm	109.95
11-8196K.....	Med	109.95
11-8197K.....	Lg.....	109.95
11-8198K.....	XL.....	109.95
11-8199K.....	2X.....	109.95
11-8200K.....	3X.....	109.95
11-8201K.....	4X.....	109.95



LYNGSOE CSA FIRE RETARDANT FALL ARREST RAIN JACKET

Tuckable detachable hood with draw strings. Hood is hard hat compatible. Velcro cuffs, 2 front pockets with button closure. Concealed vented back. Reinforced opening for fall restraint access. Waterproof: 13,000mm

Orange

11-8204K.....	Sm	239.95
11-8205K.....	Med	239.95
11-8206K.....	Lg.....	239.95
11-8207K.....	XL.....	239.95
11-8208K.....	2X.....	239.95
11-8209K.....	3X.....	239.95
11-8210K.....	4X.....	239.95



HELLY HANSEN ALTA INSULATED JACKET

Shell: 100% Polyester 200 g/m², Insulated with 100 g/m² in body, 80 g/m² in sleeves. Waterproof, windproof, breathable. Detachable hood. Fully taped construction. High stand collar. Lower-front pockets with flaps. Napoleon Pocket with YKK zipper. Shoulder bands for attaching radio/cell phone. Adjustable cuffs. High Viz and reflective bands. Meets CSA Z96, Class 2, Level 2.

Alta Insulated Jacket - Model 71288-369 (Yellow)

11-2471MSm.....	234.95
11-2472MMed.....	234.95
11-2473MLg.....	234.95
11-2474MXL.....	234.95
11-2475M2X.....	234.95
11-2476M3X.....	234.95
11-2477M4X.....	234.95
11-2478M5X.....	234.95



HELLY HANSEN ALTA SHELL JACKET

Fabric: Main 100% polyester, 200 g/m². Lining 100% Nylon Taffeta 58 g/m². Insulation 100g/m² in body and 80 g/m² in sleeves. Fully taped construction. YKK centre front zip with stormflap. Back placket with chin guard in brushed polyester. Packable hood with draw cord adjustment at front and velcro adjustment at back. Hood designed to be used with a helmet. Two hand pockets with flap and velcro closure. Napoleon pocket, no need to open the jacket to access. Velcro adjustment at cuffs. Loop for ID card. Extended back for comfort. Zipper for entry inside garment for logo applications. CSA Z96 Class 2 Level 2.

Alta Shell Jacket - Model 71088-369 (Yellow)

11-2322MSm.....	164.95
11-2323MMed.....	164.95
11-2324MLg.....	164.95
11-2325MXL.....	164.95
11-2326M2X.....	164.95
11-2327M3X.....	164.95
11-2328M4X.....	164.95
11-2329M5X.....	164.95



HELLY HANSEN ALTA SHELL BIB PANTS

The Alta Shell Bib will help to keep you safe and visible in dim conditions, with fluorescent yellow color and reflective stripes at the bottom of the leg. Built with Helly Tech Performance fabric for waterproof, windproof and breathable protection with fully sealed seams to keep you dry when the weather turns. Elastic suspenders with quick snaps and button sides, make adjusting the fit along with getting in/out of these bibs easy.

Alta Shell Bib Pant - Model 71443-369 (Yellow)

11-2794MSm.....	129.95
11-2795MMed.....	129.95
11-2796MLg.....	129.95
11-2797MXL.....	129.95
11-2798M2X.....	129.95
11-2799M3X.....	129.95
11-2800M4X.....	129.95
11-2801M5X.....	129.95

www.mercersmarine.com



- Always Open
- Sale & Feature items
- View Catalogue



- Thousands of products
- Updated Regularly
- Up to date Pricing



- Mobile Friendly
- Shop from anywhere at anytime

Also find us on



Workwear

PIONEER HI-VIZ 6 IN 1 PARKA

300 denier PU coated oxford polyester. Inner and outer jacket CSA Z96-15 (Orange and Yellow models, Class 2 Level 2, Class 3 when worn combined with 5040BB/5041BB/5043/5044). (Black model Class 1 Level 2). 3M® Scotchlite™ reflective tape. 100% waterproof and windproof. All seams taped and heat sealed. Outer jacket features: quilted lining, adjustable hood folds into collar, 2 large front cargo pockets, 2 inner pockets, full front zipper with snap closure storm flap, 7" side zippers for greater mobility, storm cuffs, embroidery access zipper. Inner jacket features: quilted lining, removable sleeves, comfort collar, 2 large front cargo pockets, 2 inner pockets, **reversible to black**.

ORANGE (STYLE 5020BB)

13-8747MXS	13-8752M2X
13-8748MSm	13-8753M3X
13-8749MMed	13-8754M4X
13-8750MLg	13-8755M5X
13-8751MXL	

All Sizes \$179.95

YELLOW (STYLE 5021BB)

13-8756MXS	13-8761M2X
13-8757MSm	13-8762M3X
13-8758MMed	13-8763M4X
13-8759MLg	13-8764M5X
13-8760MXL	

All Sizes \$179.95

BLACK (STYLE 5025)

11-4104MSm	11-4109M3X
11-4105MMed	11-4110M4X
11-4106MLg	11-4111M5X
11-4107MXL	
11-4108M2X	

All Sizes \$179.95



PIONEER HI-VIZ QUILTED OVERALL

300 denier PU coated oxford polyester with warm quilted polyester lining. CSA Z96-15 (Orange and Yellow models, Class 2 Level 2, Class 3 when worn combined with 5020BB/5021BB). (Black model Class 1 Level 2). 3M® Scotchlite™ reflective tape. 100% waterproof and windproof. 2-way zipper closure with snap placket. Premium adjustable elastic suspenders with quick-release clips. Elastic waist. 2 front cargo pockets. Sealed inside chest pocket and outside chest pockets. 20" boot access 2-way leg zipper with snap storm covers.

ORANGE (STYLE 5040BB)

13-8766MSm	13-8770M2X
13-8767MMed	13-8771M3X
13-8768MLg	13-8772M4X
13-8769MXL	13-8773M5X

All Sizes \$114.95

YELLOW (STYLE 5041BB)

13-8775MSm	13-8779M2X
13-8776MMed	13-8780M3X
13-8777MLg	13-8781M4X
13-8778MXL	

All Sizes \$114.95

BLACK (STYLE 5042)

11-4112MSm	11-4116M2X
11-4113MMed	11-4117M3X
11-4114MLg	11-4118M4X
11-4115MXL	11-4119M5X

All Sizes \$114.95

Prices are subject to change. Check our website for up to date prices. www.mercersmarine.com

CLOTHING



325



PIONEER "6-IN-1" BOMBER WITH REFLECTIVE STRIPES

300 Denier PU coated oxford polyester. Inner and outer jacket CSA Z96-15 Class 2 Level 2 (Class 3 when worn combined with 5041BB or 5044). 3M Scotchlite reflective tape. 100% waterproof and windproof. Taped and heat sealed seams.

OUTER JACKET FEATURES •fully mesh lined •adjustable cuffs •full front zipper with snap closure storm flap •2 radiophone clip straps •2 large front cargo pockets, 1 cell phone pocket •4 inner pockets

INNER JACKET FEATURES: •quilted lining •removable sleeves •comfort collar •2 large front cargo pockets •2 inner pockets •reversible to black

ORANGE (STYLE 5022)

13-8232MXS	13-8178M2X
13-8174MSm	13-8179M3X
13-8175MMed	13-8180M4X
13-8176MLg	13-8233M5X
13-8177MXL	

All Sizes \$184.95

YELLOW (STYLE 5023)

13-8234MXS	13-8171M2X
13-8167MSm	13-8172M3X
13-8168MMed	13-8173M4X
13-8169MLg	13-8235M5X
13-8170MXL	

All Sizes \$184.95



PIONEER HI-VIZ INSULATED PARKA

300 denier PU coated oxford polyester.CSA Z96-15 Class 2 Level 2. 100% waterproof and windproof. 5.3 oz (180 gsm) poly filling.All seams taped and heat sealed. 2 large front cargo pockets.Cell/radiophone pocket on left chest.

Inside storage pocket and pouch pocket.2-way derlin zipper with snap placket.Embroidery access zipper. Adjustable hood folds into collar. Knitted storm cuffs. Zip-to-top fleece-lined collar.

Style 5030 Orange

11-3728M.....Sm	11-3732M.....2X
11-3729M.....Med	11-3733M.....3X
11-3730M.....Lg	11-3734M.....4X
11-3731M.....XL	11-3735M.....5X

Style 5031 Yellow

11-3736M.....Sm	11-3740M.....2X
11-3737M.....Med	11-3741M.....3X
11-3738M.....Lg	11-3742M.....4X
11-3739M.....XL	11-3743M.....5X

All Sizes \$84.95



PIONEER HI-VIZ INSULATED BOMBER

300 denier PU coated oxford polyester.CSA Z96-15 Class 2 Level 2.100% waterproof and windproof. 5.3 oz (180 gsm) poly filling.All seams taped and heat sealed.2 large front cargo pockets.Cell/radiophone pocket on left chest.

Inside storage pocket and pouch pocket. 2-way derlin zipper with snap placket. Embroidery access zipper.Adjustable hood folds into collar.Knitted storm cuffs. Zip-to-top fleece-lined collar.

Style 5032 Orange

11-3789M.....Sm	11-3793M.....2X
11-3790M.....Med	11-3794M.....3X
11-3791M.....Lg	11-3795M.....4X
11-3792M.....XL	11-3796M.....5X

Style 5033 Yellow

11-3798M.....Sm	11-3802M.....2X
11-3799M.....Med	11-3803M.....3X
11-3800M.....Lg	11-3804M.....4X
11-3801M.....XL	11-3805M.....5X

All Sizes \$84.95



PIONEER HI-VIZ JACKET

Waterproof/Breathable 5,000 / 5,000. Premium 300 Denier oxford polyester. CSA Z96-15 Class 2 Level 2. 3M Scotchlite® reflective tape. Taped and heat sealed seams. Waterproof pit zippers. Detachable, adjustable drawstring hood, folds into collar. 2 radiophone clip straps. 3 waterproof zip pockets: 2 chest, 1 sleeve. 2 large front zip cargo pockets. Inner placket cell phone pocket, inside zip pocket. Adjustable drawstring waist and hem. Embroidery access zipper. 2-way front zipper with brass snap placket. Comfort fleece collar and chin guard.

ORANGE (STYLE 5200)

13-8715MSm	13-8719M2X
13-8716MMed	13-8720M3X
13-8717MLg	13-8721M4X
13-8718MXL	

All Sizes \$164.95

YELLOW (STYLE 5201)

13-8723MXS	13-8727MXL
13-8724MSm	13-8728M2X
13-8725MMed	13-8729M3X
13-8726MLg	13-8730M4X

All Sizes \$164.95



GKS INSULATED WORK PARKA

Superb quality parka. Heatlocker and quilted polar fleece. Sealed seams. Very warm. Two snap chest pockets. 4" reflective striping. Fleece attached vest. Inside pocket. Detachable zip hood.

Colour: Black

12-6294MSm	259.95
12-6295MMed	259.95
12-6296MLg	259.95
12-6297MXL	259.95
12-6298M2X	284.50
12-6299M3X	284.50
12-6319M4X	284.50
12-6320M5X	284.50

GKS INSULATED WORK PANTS

Endura 600 D Heatlocker and quilted polar fleece. Sealed seams. 4" reflective striping. Front pocket. Storm cuff in leg. Exterior 100% nylon PU. 100% polyester double lining.

Colour: Black

12-6300MSm	229.95
12-6301MMed	229.95
12-6302MLg	229.95
12-6303MXL	229.95
12-6304M2X	249.50
12-6305M3X	249.50
12-6321M4X	249.50
12-6322M5X	249.50



PIONEER HI-VIZ POLYESTER FLEECE HOODIE

Premium 10.5 oz (356 gms) polyester fleece. CSA Z96-15 Class 2 Level 2 (Class 3 when worn with 5586 or 5576). 3M Scotchlite® reflective tape. Zips into inner zipper on 5585 parka or 5584 bomber to make 3-in-1 jacket. Detachable drawstring hood. Elastic wrists and hem. 2 front slash pockets. Full front zipper. 2 radiophone clip straps.

ORANGE (STYLE 6924)

11-3847MSm	11-3851M2X
11-3848MMed	11-3852M3X
11-3849MLg	11-3853M4X
11-3850MXL	11-3854M5X

YELLOW (STYLE 6925)

11-3855MXS	11-3860M2X
11-3856MSm	11-3861M3X
11-3857MMed	11-3862M4X
11-3858MLg	11-3863M5X
11-3859MXL	

BLACK (STYLE 6925BK)

11-4063MSm	11-4067M2X
11-4064MMed	11-4068M3X
11-4065MLg	11-4069M4X
11-4066MXL	11-4070M5X

All Sizes \$64.95



PIONEER HI-VIZ ROCK INSULATED PARKA

100% waterproof 300D oxford polyester with PU coating. CSA Z96-15 Class 2 Level 2 (becomes Class 3 when worn with hi-viz pant featuring reflective leg bands). ANSI/ISEA 107-2020 Class 3 Type P and R. StarTech reflective tape. Superior tear- and abrasion-resistant fabric. Double stitched, taped and heat sealed seams. Outer jacket: liberal fit and full back vent for working comfort, fully taffeta lined, 2 lower flap pockets, full front zipper plus inner zipper for fleece lining, snap-off 3-piece hood folds into collar, adjustable cuffs. Zip-out inner fleece jacket: warm, 8.2 oz (280 GSM) black fleece liner, 2 lower pockets slash pockets, reversible head main zipper, loops at neck and wrists to attach to outer jacket.

ORANGE (STYLE 5632)

13-8238MSm	13-8242M2X
13-8239MMed	13-8243M3X
13-8240MLg	13-8244M4X
13-8241MXL	13-8245M5X

All Sizes \$134.95

YELLOW (STYLE 5633)

13-8247MSm	13-8251M2X
13-8248MMed	13-8252M3X
13-8249MLg	13-8253M4X
13-8250MXL	13-8254M5X

All Sizes \$134.95



PIONEER HI-VIZ ROCK INSULATED BIB PANTS

100% waterproof 300D oxford polyester with PU coating. CSA Z96-15 Class 3 Level 2 when worn with Class 2 Level 2 top featuring reflective arm bands. ANSI/ISEA 107-2020 Class E Supplemental Type. StarTech reflective tape. Superior tear- and abrasion-resistant fabric. Double stitched taped and heat sealed seams. Elastic suspenders with Pioneer logo, spreader bar and buckles. 2 slash pockets. 18" boot access zippers.

ORANGE (STYLE 5053)

13-8265MSm	13-8269M2X
13-8266MMed	13-8270M3X
13-8267MLg	13-8271M4X
13-8268MXL	13-8272M5X

All Sizes \$89.95

YELLOW (STYLE 5054)

13-8274MSm	13-8278M2X
13-8275MMed	13-8279M3X
13-8276MLg	13-8280M4X
13-8277MXL	13-8281M5X

All Sizes \$89.95



SURVEYOR'S VEST

600 denier oxford polyester, PU coated. StarTech™ reflective tape. Radiophone pocket on chest. 12 storage pockets. Back ruler slot. 2 large back pack pockets. D ring access slot. (V1010710) **STYLE 695 - RED**

13-7924MSm	13-7928M2X
13-7925MMed	13-7929M3X
13-7926MLg	13-7940M4X
13-7927MXL	13-7941M5X

All Sizes \$60.95



HI-VIZ SURVEYOR'S SAFETY VEST

600 denier oxford polyester, PU coated. CSA Z96-15 Class 2 Level 2. ANSI/ISEA 107-15 Class 2 Type P and R. StarTech™ reflective tape. Radiophone pocket on chest. 12 storage pockets. Back ruler slot. 2 large back pack pockets. Radiophone clip strap. D ring access slot. (V1010340) **STYLE 6696 - YELLOW**

13-7930MSm	13-7934M2X
13-7931MMed	13-7935M3X
13-7932MLg	13-7966M4X
13-7933MXL	

All Sizes \$67.95



HI-VIZ FITTER'S COWGRAIN GLOVE

One-piece palm. Reflective. Inside elastic, rubberized cuff.

Orange	
16-1000PLg	9.29



PIONEER HI-VIZ FREEZER JACKET

These Pioneer Safety Jackets promote durability with a strongly woven diamond quilted polyester material with 3.5 oz insulation. The durable fabric and the double stitched reflective tape enhance visibility in low-light condition. The Rib knit gusset action back allows for breathability while the black micro fleece comfort collar keeps users comfortable and insulated in cold/harsh weather conditions. For added utility, these safety jackets feature multiple pockets including 2 front slash pockets and 1 inside chest cell phone pocket.

ORANGE (STYLE 5015)

11-4230MSm	11-4234M2X
11-4231MMed	11-4235M3X
11-4232MLg	11-4236M4X
11-4233MXL	11-4237M5X

All Sizes \$51.95

YELLOW (STYLE 5016)

11-4238MSm	11-4242M2X
11-4239MMed	11-4243M3X
11-4240MLg	11-4244M4X
11-4241MXL	11-4245M5X

All Sizes \$51.95

BLACK (STYLE 5017)

11-4246MSm	11-4250M2X
11-4247MMed	11-4251M3X
11-4248MLg	11-4252M4X
11-4249MXL	11-4253M5X

All Sizes \$51.95



PIONEER CSA TEAR AWAY "ZIPPER" VEST

Tricot polyester interlock front. Full mesh back panel. Zipper front with tear-away on left side. 5 point tear-away. 4 sealed pockets. 2 radiophone clip straps. D ring access slot. 6935/6936 - CSA Z96-15 Class 2 Level 2 and ANSI/ISEA 107-15 Class 2 Type P and R / 6937 - CSA Z96-15 Class 1 Level 2 and ANSI/ISEA 107-15 Class 1 Type O

(V1021150) Orange Model 6935

11-4120MXS
11-4121MSm
11-4122MMed
11-4123MLg
11-4124MXL
11-4125M2X
11-4126M3X
11-4127M4X
11-4128M5X

(V1021260) Yellow Model 6936

11-4129MXS
11-4130MSm
11-4131MMed
11-4132MLg
11-4133MXL
11-4134M2X
11-4135M3X
11-4136M4X
11-4137M5X

(V1021170) Black Model 6937

11-4146MXS
11-4147MSm
11-4148MMed
11-4149MLg
11-4150MXL
11-4151M2X
11-4152M3X
11-4153M4X
11-4154M5X

All Models & Sizes \$24.95

HI-VIZ SAFETY TEAR AWAY VEST

Tricot polyester interlock. CSA Z96-15 Class 2 Level 2 ANSI/ISEA 107-15 Class 2 Type P and R. StarTech™ reflective tape. ID pocket. 5 point tear-away. 4 sealed pockets. Radiophone clip strap. D ring access slot. Adjustable 1 size up at front.

(V1021061) Yellow (Model 6931)

13-7936MSm/Med	13-7938M2X/3X
13-7937MLg/XL	13-7939M4X/5X

(V1020951) Orange (Model 6930)

13-8194MSm/Med	13-8196M2X/3X
13-8195MLg/XL	13-8197M4X/5X

All Sizes \$15.95



HI-VIZ FLAME RESISTANT VEST

FR treated polyester mesh. Meets EN ISO 14116 Index 1. Must be worn over an FR sleeved garment. CSA Z96-15 Class 2 Level 2. ANSI/ISEA 107-15 Class 2 Type P and R. 5 point tear-away. StarTech™ FR reflective tape. D ring access slot. Adjustable 1 size up at front.

(V2510860) **STYLE 6916A - YELLOW**

11-3842M.....Sm/Med	31.95
11-3843M.....Lg/XL.....	31.95
11-3844M.....2X/3X	31.95
11-3845M.....4X/5X	31.95



VIKING OPEN ROAD SURVEYOR VESTS

150D Denier polyester material with double hem stitched pockets and seams to increase wear resistance from washing. Built to last with quality duty brass snaps and grommets. "X" CSA reflective striping configuration. Mesh underarm cooling ventilation panels. 2" Vi-Brance reflective Material in 4" contrasting tape meets WCB/Worksafe/DOT configuration. Fully compliant with CSA Z96-09 Class 2, Level 2 and becomes CSA Class 3 in combination with right model arm and leg bands. Fully compliant with ANSI/ISEA 107-2010 Class 2, Level 2

Orange (Model 6165-O)

13-8352M.....Sm	13-8356M	2X
13-8353M.....Med	13-8357M	3X
13-8354M.....Lg	13-8358M	4X
13-8355M.....XL		

Yellow (Model 6165-G)

13-8359M.....Sm	13-8363M	2X
13-8360M.....Med	13-8364M	3X
13-8361M.....Lg	13-8365M	4X
13-8362M.....XL		

All Sizes \$33.95



PIONEER THINSULATE TOQUE

100% acrylic knitted. Thinsulate® lined. One Size.

11-3638M.....Orange	6.59
11-3639M.....Yellow.....	6.59



REFLECTIVE BANDS

4" adjustable arm bands. 3M Scotchlite™ reflective tape. Helps other garments meet CSA standards. Also great for recreational use.

12-242R.....14" Long Wrist (Orange)	7.79
12-243R.....14" Long Wrist (Yellow)	7.79
12-244R.....18" Long Ankle (Orange).....	7.95
12-245R.....18" Long Ankle (Yellow)	7.95



HI-VIZ. SAFETY SASH

Premium 2" elastic. Adjustable elastic waist band and chest straps. Startech™ reflective tape. 4 point tear-away. Quick-release waist buckle. **MODEL 5592**

50-209M.....One Size	19.95
----------------------------	-------



SELLSTROM KNEEPRO ULTRA FLEX III KNEE PAD

Articulating hinged design ensures proper placement all day long. Made with strong, flexible hard plastic outer shells that extend well above, below and to the inside/outside of the knee. Perfectly placed curved non-marking Grip Strip on the outside. KneePro Hybrid Ultra Flex III version features a three layer, 3/4" thick closed cell foam pad with built-in GEL packs for the ultimate in knee protection

11-4155M.....One Size	64.95
-----------------------------	-------



VIKING OPEN ROAD "FR" SURVEYORS VEST

100% Cotton FR-treated fabric for comfort and durability. Built to last heavy-duty brass snaps and grommets. Mesh side vents. Dual reflective chest straps. Cell/Radio pocket with hook-and-loop fastener. Safety D-ring slot access on back. 14" zippered pack across entire back area. 8 pockets with hook-and-loop fastener (5 outside; 3 inside). Brass grommets on lower front pockets for surveyor tape dispenser. Long ruler slot pocket on left back. Fully compliant with CSA Z96-15 Class 1, Level 2. Fully compliant with ANS/ISEA 107-2015 Type O, Class 1, ASTM D6413 (FR) Model 6165FR

13-8366M.....Sm	13-8370M2X
13-8367M.....Med	13-8371M3X
13-8368MLg	13-8372M4X
13-8369MXL	

All Sizes \$52.95



VIKING OPEN ROAD "BTE" VEST - MODEL 6110

Entry level safety vest. Polyester mesh for comfort and breathability. 2" Vi-Brance reflective Material in 4" contrasting tape meets WCB/Worksafe/DOT configuration. Fully compliant with CSA Z96-09 Class 2, Level 2 and becomes CSA Class 3 in combination with right model arm and leg bands. Fully compliant with ANSI/ISEA 107-2010 Class 2, Level 2.

13-8348MSm/Med	13-8350M2X/3X
13-8349M.....Lg/XL	13-8351M4X/5X

All Sizes \$10.95



WORK KING LINED INSULATED PARKA

Fabric: 100% Polyester with PU coating. Lining: Quilted 6 oz polyester insulation. 3M Scotchlite Reflective Material with 4" contrast backing. Black cuffs and hemline for hiding dirt. Dual microphone loops. ID pocket with loss-proof flap. Quick-release hard hat hood. Snap front fly. Storm cuffs. CSA-Z96-09 Compliant - Class 2, Level 2. ANSI107-2010 Compliant -Class 3, Level 2.

Model S176

13-1257M.....Sm	139.95
13-1258M.....Med	139.95
13-1259M.....Lg	139.95
13-1260M.....XL	139.95
13-1261M2X	150.50
13-1262M3X	150.50
13-1263M4X	167.95
13-1264M5X	167.95

MERCER'S
YOUR WORKWEAR HEADQUARTERS
mercersmarine.com





WORK KING



WORK KING



WORK KING



WORK KING 5 IN 1 LINED JACKET

100% Polyester with PU coating (shell + liner). 100% Polyester lining (shell + liner). 100% 6 oz Quilted polyester insulation (liner). 3M Scotchlite Reflective Material with 4" contrast backing. Black cuffs and hemline for hiding dirt. **Removable hi-vis liner (reverses to black) with zip-off sleeves.** 2 microphone loops (shell + liner). Multi-pocketed (shell + liner). ID pocket with hook + loop closure (shell + liner). Quick-release hard hat hood. Embroidery zipper (shell). CSA-Z96-09 Compliant - Class 2, Level 2. ANSI107-2010 Compliant - Class 3, Level 2. **Model S426**

YELLOW

13-1288MXS192.50
13-1289MSm192.50
13-1290MMed192.50
13-1291MLg192.50
13-1292MXL192.50
13-1293M2X209.95
13-1294M3X209.95
13-1295M4X232.95
13-1296M5X232.95

ORANGE

13-1297MSm192.50
13-1298MMed192.50
13-1299MLg192.50
13-1300MXL192.50
13-1301M2X209.95
13-1302M3X209.95
13-1303M4X232.95
13-1304M5X232.95

WORK KING 3 IN 1 LINED BOMBER JACKET

Fabric: 300D Oxford 100% polyester PU coated. Liner: 300g Polar Fleece. Jacket: quick release hood. Elastic waist. Dual entry pockets. Adjustable cuffs. 3M Scotchlite reflective material w/ 4" contrast backing. Black cuffs and hemline for hiding dirt. Liner: On seam lower pockets. **Model S413**

YELLOW

13-1418MSm184.95
13-1419MMed184.95
13-1420MLg184.95
13-1421MXL184.95
13-1422M2X201.50
13-1423M3X201.50

WORK KING LINED INSULATED BIB OVERALLS

Fabric: 100% Polyester with PU coating. Lining: 6 oz Quilted polyester insulation. 3M Scotchlite Reflective Material with 4" contrast backing. Black leg bottoms for hiding dirt. Ankle to hip Delrin zippers. Hammer loop + ruler pocket. Elasticized back waist. Fly front over 2-way zipper. Turned hem allows for 3" leg extension.

Model S798

YELLOW

13-1436MSm131.95
13-1437MMed131.95
13-1438MLg131.95
13-1439MXL131.95
13-1440M2X143.50
13-1441M3X143.50
13-1442M4X157.50
13-1443M5X157.50

ORANGE

13-1444MSm131.95
13-1445MMed131.95
13-1446MLg131.95
13-1447MXL131.95
13-1448M2X143.50
13-1449M3X143.50
13-1450M4X157.50
13-1451M5X157.50

SHOP 24/7 FROM THE COMFORT OF YOUR OWN HOME

- *Up to date Pricing*
- *New Products*
- *Stock Status*
- *Additional product info*
- *And more*



www.mercersmarine.com



WORK KING**WORK KING LINED INSULATED DUCK JACKET**

Fabric : 10 oz 100% cotton duck. Lining: quilted 6 oz polyester insulation. Multi-pocketed. Quick release hard hat hood. Action back. Knit storm cuffs. Articulated sleeves. 3M Scotchlite reflective material with 4" yellow backing. Double needle stitching on reflective tape.

Navy Model S457

13-1305M.....Sm	148.95
13-1306M.....Med	148.95
13-1307M.....Lg	148.95
13-1308M.....XL	148.95
13-1309M.....2X	160.95
13-1310M.....3X	160.95
13-1311M.....4X	174.95
13-1312M.....5X	174.95

Orange Model S457

13-1313M.....Sm	148.95
13-1314M.....Med	148.95
13-1315M.....Lg	148.95
13-1316M.....XL	148.95
13-1317M.....2X	160.95
13-1318M.....3X	160.95
13-1319M.....4X	174.95
13-1320M.....5X	174.95

WORK KING**WORK KING LINED INSULATED DUCK OVERALLS**

Fabric : 10 oz 100% cotton duck. Lining: quilted 6 oz polyester insulation. Multi-pocketed. Double knees. Storm flaps over ankle to hip brass zippers. Back elastic waist. Adjustable shoulder straps. 3M Scotchlite reflective material with 4" yellow backing.

Navy Model S757

13-1321M.....Sm	144.95
13-1322M.....Med	144.95
13-1323M.....Lg	144.95
13-1324M.....XL	144.95
13-1325M.....2X	157.50
13-1326M.....3X	157.50
13-1327M.....4X	167.95
13-1328M.....5X	167.95

Orange Model S757

13-1329M.....Sm	144.95
13-1330M.....Med	144.95
13-1331M.....Lg	144.95
13-1332M.....XL	144.95
13-1333M.....2X	157.50
13-1334M.....3X	157.50
13-1335M.....4X	167.95
13-1336M.....5X	167.95

NEW**WORK KING****WORK KING INSULATED SAFETY OVERALLS**

Built to not only help keep you warm but to provide the comfort and ease of movement you need on the job site. The drop down hem allows for an extra 3" for those who need more length. 300D Poly Oxford with PU coating and antifreeze finish. Lining: 6 oz quilted polyester insulation. 3M Scotchlite Reflective Material with 4" contrast backing. Black leg bottoms for hiding dirt. Zip-to-the-hip nylon zippers. Hammer loop plus ruler pocket. Elasticized back waist. Fly front over 2-way nylon zipper. Turned under hem allows for 3" tall extension.

Model S798 - Black

13-1428M.....Sm	131.95
13-1429M.....Med	131.95
13-1430M.....Lg	131.95
13-1431M.....XL	131.95
13-1432M.....2X	143.50
13-1433M.....3X	143.50
13-1434M.....4X	157.50
13-1435M.....5X	157.50

WORK KING**WORK KING CSA TRAFFIC HOODIE**

Fabric: 100% polyester fleece. Anti-pill finish. Quick-release hood. Rib knit cuffs and waist. Lower pouch pockets. 4" combined striping. 3M Scotchlite Reflective Material. Meets CSA-Z96-09, Class 2, Level 2. Meets ANSI107-2004, Class 2, Level 2. Meets WCB/Worksafe striping configuration.

Model S494**YELLOW**

13-7787M.....Sm.....	76.95
13-7788M..... Med.....	76.95
13-7789M.....Lg.....	76.95
13-7790M.....XL.....	76.95
13-7791M.....2X.....	83.95
13-7792M.....3X.....	83.95
13-7793M.....4X.....	92.95
13-7794M.....5X.....	92.95

ORANGE

13-7779M.....Sm.....	76.95
13-7780M..... Med.....	76.95
13-7781M.....Lg.....	76.95
13-7782M.....XL.....	76.95
13-7783M.....2X.....	83.95
13-7784M.....3X.....	83.95
13-7785M.....4X.....	92.95
13-7786M.....5X.....	92.95



WORK KING 4-IN-1 SAFETY JACKET

This versatile 4-in-1 jacket offers a removable liner that reverses to black. The Ripstop fabric is waterproof and breathable so it will keep you warm and dry on the job site. Shell: 100% polyester 300D Ripstop with PU membrane, taped seams, Waterproof/Breathable 5000/5000 MVP/24hr and antifreeze finish. Lining: Removable hi-vis liner (reverses to black) with quilted 3.5 oz polyester insulation. 3M Scotchlite Reflective Material with 4" contrast backing. Quick release hard hat hood with hidden snaps. Multi-pocket (shell/liner). Inside pockets. Storm flap with snap closure over front nylon zipper. Waterproof welded chest and sleeve zippers with reflective tape. Black contrast cuffs and hemline for ease of laundering. Dual microphone loops. Embroidery access zipper (shell).

Model S187 - Yellow

13-1525M	XS	264.95
13-1526M	Sm	264.95
13-1527M	Med	264.95
13-1528M	Lg	264.95
13-1529M	XL	264.95
13-1530M	2X	285.50
13-1531M	3X	285.50
13-1532M	4X	311.50
13-1533M	5X	311.50

Model S187 - Orange

13-1534M	XS	264.95
13-1535M	Sm	264.95
13-1536M	Med	264.95
13-1537M	Lg	264.95
13-1538M	XL	264.95
13-1539M	2X	285.50
13-1540M	3X	285.50
13-1541M	4X	311.50
13-1542M	5X	311.50

Model S187 - Black

13-1543M	XS	264.95
13-1544M	Sm	264.95
13-1545M	Med	264.95
13-1546M	Lg	264.95
13-1547M	XL	264.95
13-1548M	2X	285.50
13-1549M	3X	285.50
13-1550M	4X	311.50
13-1551M	5X	311.50



WORK KING SAFETY OVERALLS

If your job site requires you to stay warm and dry this overall is the perfect fit for you. It will provide you with the warmth and comfort you need with the added benefit of being waterproof and breathable. The drop down hem allows for an extra 3" for those who need more length. Shell: 100% polyester 300D Ripstop with PU membrane, taped seams, Waterproof/Breathable 5000/5000 MVP/24hr and antifreeze finish. Lining: Quilted 6 oz polyester insulation. Taped seams, Waterproof/ Breathable. 3M Scotchlite Reflective Material with 4" contrast backing. Welded waterproof chest zippers with reflective tape. Zip-to-the-hip nylon zippers and adjustable shoulder straps. Chest and pencil pocket. Hammer loop and ruler pocket. Back elastic waist. Turned under hem allows for 3" tall extension. Black contrast hemline hides dirt.

Model S876 - Yellow

13-1552M	XS	174.95
13-1553M	Sm	174.95
13-1554M	Med	174.95
13-1555M	Lg	174.95
13-1556M	XL	174.95
13-1557M	2X	188.95
13-1558M	3X	188.95
13-1559M	4X	206.50
13-1560M	5X	206.50

Model S876 - Orange

13-1561M	XS	174.95
13-1562M	Sm	174.95
13-1563M	Med	174.95
13-1564M	Lg	174.95
13-1565M	XL	174.95
13-1566M	2X	188.95
13-1567M	3X	188.95
13-1568M	4X	206.50
13-1569M	5X	206.50

Model S876 - Black

13-1570M	XS	174.95
13-1571M	Sm	174.95
13-1572M	Med	174.95
13-1573M	Lg	174.95
13-1574M	XL	174.95
13-1575M	2X	188.95
13-1576M	3X	188.95
13-1577M	4X	206.50
13-1578M	5X	206.50



FORCEFIELD**NEW**

Also available in HiVis Yellow

**FORCEFIELD 4 IN 1 TORNGAT HI VIS SAFETY PARKA**

A heavy-duty safety parka created to withstand every variety of inclement weather. Take advantage of well-placed pockets, water-resistant material, tear-resistant construction, and an industry-standard design optimized for ultimate functionality. Rain, wind, sleet, and snow go from exasperating to scarcely noticeable. Keep yourself visible, dry, and fully equipped under any outdoor conditions.

Jacket - Orange

18-5091M Sm	18-5096M3X
18-5092MMed	18-5097M4X
18-5093MLg	18-5098M5X
18-5094MXL	18-5099M6X
18-5095M2X	

Jacket - Yellow

18-5081M Sm	18-5086M3X
18-5082MMed	18-5087M4X
18-5083MLg	18-5088M5X
18-5084MXL	18-5089M6X
18-5085M2X	

All Forcefield 4 in 1 Torngat Hi Vis Safety Parka \$279.95

FORCEFIELD**NEW****FORCEFIELD HI VIS WINTER SAFETY OVERALLS**

Our durably engineered, heavy-duty safety overall is made for resolute protection and long-lasting use. Make your winter labor less of a chore with an overall that shields and protects while allowing you to maintain full visibility. Designed to withstand relentless levels of wind and water, the classic design features a tear-resistant polyurethane shell for confronting the elements and repelling a wide range of harsh conditions.

Overalls - Orange

18-6011M Sm	18-6015M2X
18-6012MMed	18-6016M3X
18-6013MLg	18-6017M4X
18-6014MXL	18-6018M5X

Overalls - Yellow

18-6001M Sm	18-6005M2X
18-6002MMed	18-6006M3X
18-6003MLg	18-6007M4X
18-6004MXL	18-6008M5X

All Forcefield Hi Vis Winter Safety Overalls \$109.95

NEW**FORCEFIELD**

Workwear

**FORCEFIELD HI VIS SAFETY SOFTSHELL**

Designed for road crews, first responders, and workers requiring round-the-clock visibility, our machine washable safety softshell functions as a warm yet breathable transitional garment, ideal for the change of seasons. The softshell features a lightweight, versatile lining with outside pockets and is easy to layer with other articles of clothing. A great non-bulky option perfect for a range of jobs no matter the weather.

Jacket - Yellow

18-5054M Sm	18-5058M2X
18-5055MMed	18-5059M3X
18-5056MLg	18-5060M4X
18-5057MXL	

Jacket - Orange

18-5063M Sm	18-5067M2X
18-5064MMed	18-5068M3X
18-5065MLg	18-5069M4X
18-5066MXL	

Jacket - Black

18-5072M Sm	18-5076M2X
18-5073MMed	18-5077M3X
18-5074MLg	18-5078M4X
18-5075MXL	

All Forcefield Hi Vis Safety Softshells

\$59.95

Prices are subject to change. Check our website for up to date prices. www.mercersmarine.com

CLOTHING

**335**

Pioneer Flame Resistant Clothing



Also Available in Black by Special Order. Please Inquire.



FLAME RESISTANT INSULATED COVERALL

Shell fabric 100% cotton. FR treated. 6.5 oz (220 GSM) modacrylic FR insulation. Material and all components meet CGSB 155.20-2000. Thermal Protective Performance value: contact test 18.8 CSA Z96-15 Class 1 Level 2 and Class 1 Level FR ANSI/ISEA 107-15 Class 1 Type O. Meets ASTM F1506-10a, NFPA 70E and CSA Z462-15 ATPV 46 cal/cm² (Arc Thermal Protective Value) ARC 4 Arc Rating Category. **For complete specifications please visit our website.**

MODEL 5522A.

13-8856MSm	13-8860M2X
13-8857MMed	13-8861M3X
13-8858MLg	13-8862M4X
13-8859MXL	

All Sizes \$ 449.95

FLAME RESISTANT INSULATED PARKA & OVERALLS

Shell fabric 100% cotton, FR treated.6.5 oz (220 GSM) modacrylic FR insulation. Material and all components meet CGSB 155.20-2000. Thermal Protective Performance (TPP) value: contact test 18.8.CSA Z96-15 Class 1 Level 2 and Class 1 Level FR.ANSI/ISEA 107-15 Class 1 Type O.Meets ASTM F1506-10a, NFPA 70E and CSA Z462-15.ATPV 46 cal/cm² (Arc Thermal Protective Value).ARC 4 Arc Rating Category.All metal components are concealed to ensure no arc flash conductivity.StarTech FR reflective tape.Sewn with inherently FR thread

Parka: FR brass non-locking zipper.Tough double-stitched seams.Fleece hand warmers.6 storage pockets: 2 back, 2 chest, 2 side.Action back, elastic waist and aramid storm cuffs.Radiophone clip strap.Concealed metal snaps

Overalls: 2-way FR brass non-locking zipper. 7 storage pockets: 2 back, 2 chest, 2 side, 1 tool. Adjustable elastic suspenders and elastic waist. 3/4 leg zipper plus snaps on each side. Hammer loop.

ORANGE PARKA (STYLE 5533)

13-8812MSm	13-8816M2X
13-8813MMed	13-8817M3X
13-8814MLg	13-8818M4X
13-8815MXL	13-8819M5X

BLUE PARKA (STYLE 5523)

13-8802MSm	13-8806M2X
13-8803MMed	13-8807M3X
13-8804MLg	13-8808M4X
13-8805MXL	13-8809M5X

All Sizes \$339.95

ORANGE OVERALLS (STYLE 5534A)

13-8839MSm	13-8843M2X
13-8840MMed	13-8844M3X
13-8841MLg	13-8845M4X
13-8842MXL	

BLUE OVERALLS (STYLE 5524A)

13-8830MSm	13-8834M2X
13-8831MMed	13-8835M3X
13-8832MLg	13-8836M4X
13-8833MXL	13-8837M5X

All Sizes \$329.95



Check Pricing & Stock 24/7

at

mercersmarine.com





10 OZ.



NEW



7 OZ.



Workwear

10 OZ. FR NON-INSULATED COTTON SAFETY COVERALL

100% cotton, FR treated, 10 oz (340 GSM). Material and all components meet CGSB 155.20-2000. Thermal Protective Performance (TPP) value: with the spacer 11 / contact test 8.2. CSA Z96-15 Class 1 Level 2 and Class 1 Level FR. ANSI/ISEA 107-15 Class 1 Type O. Meets ASTM F1506-10a, NFPA 70E and CSA Z462-15. ATPV 9.5 cal/cm² (Arc Thermal Protective Value). ARC 2 Arc Rating Category. StarTech FR reflective tape. Sewn with inherently FR thread. 2-way FR brass non-locking zipper. 7 storage pockets: 2 back, 2 chest, 2 side, 1 tool. 2 pass-through pockets. Adjustable wrists and ankles. Action back and elastic waist. Radiophone clip strap.

ORANGE (STYLE 5555) REG LENGTH

11-3603M.....36R	11-3611M.....52R
11-3604M.....38R	11-3612M.....54R
11-3605M.....40R	11-3613M.....56R
11-3606M.....42R	11-3614M.....58R
11-3607M.....44R	11-3615M.....60R
11-3608M.....46R	11-3750M.....62R
11-3609M.....48R	11-3751M.....64R
11-3610M.....50R	11-3752M.....66R

BLUE (STYLE 5558A) REG LENGTH

11-3579M.....36R	11-3587M.....52R
11-3580M.....38R	11-3588M.....54R
11-3581M.....40R	11-3589M.....56R
11-3582M.....42R	11-3590M.....58R
11-3583M.....44R	11-3591M.....60R
11-3584M.....46R	11-3744M.....62R
11-3585M.....48R	11-3745M.....64R
11-3586M.....50R	11-3746M.....66R

All Regular Sizes \$176.95

ORANGE (STYLE 5555T) TALL LENGTH

11-3618M.....40T	11-3625M.....54T
11-3619M.....42T	11-3626M.....56T
11-3620M.....44T	11-3627M.....58T
11-3621M.....46T	11-3628M.....60T
11-3622M.....48T	11-3753M.....62T
11-3623M.....50T	11-3754M.....64T
11-3624M.....52T	11-3755M.....66T

BLUE (STYLE 5558AT) TALL LENGTH

11-3592M.....40T	11-3599M.....54T
11-3593M.....42T	11-3600M.....56T
11-3594M.....44T	11-3601M.....58T
11-3595M.....46T	11-3602M.....60T
11-3596M.....48T	11-3747M.....62T
11-3597M.....50T	11-3748M.....64T
11-3598M.....52T	11-3749M.....66T

All Tall Sizes \$189.95

7 OZ. FLAME RESISTANT HI-VIZ SAFETY COVERALLS

FR-Tech 88% premium cotton blended with 12% high-tenacity nylon, 7 oz (240 GSM). Material and all components meet CGSB 155.20-2017 and NFPA 2112-2018 certified to UL. Average Thermal Protective Performance (TPP) value: 9 cal/cm². CSA Z96-15 Class 1 Level 2 and Class 1 Level FR. Meets ASTM F1506-2018, NFPA 70E-2018 and CSA Z462-20118. ATPV 10 cal/cm² (Arc Thermal Protective Value). ARC 2 Arc Rating Category. Double-stitched StarTech® FR reflective tape. Sewn with aramid inherently FR thread. Flame resistance guaranteed for the life of the garment. Radiophone clip strap. 2-way FR brass zipper. 7 storage pockets: 2 back, 2 chest, 2 side, 1 tool. 2 pass-through pockets. Adjustable wrists and ankles. Action back and elastic waist.

ORANGE (STYLE 7702) REG LENGTH

11-4160M.....36R	11-4168M.....52R
11-4161M.....38R	11-4169M.....54R
11-4162M.....40R	11-4170M.....56R
11-4163M.....42R	11-4171M.....58R
11-4164M.....44R	11-4172M.....60R
11-4165M.....46R	11-4173M.....62R
11-4166M.....48R	11-4174M.....64R
11-4167M.....50R	11-4175M.....66R

BLUE (STYLE 7704) REG LENGTH

11-4194M.....36R	11-4202M.....52R
11-4195M.....38R	11-4203M.....54R
11-4196M.....40R	11-4204M.....56R
11-4197M.....42R	11-4205M.....58R
11-4198M.....44R	11-4206M.....60R
11-4199M.....46R	11-4207M.....62R
11-4200M.....48R	11-4208M.....64R
11-4201M.....50R	11-4209M.....66R

All Regular Sizes \$165.95

ORANGE (STYLE 7702T) TALL LENGTH

11-4178M.....40T	11-4185M.....54T
11-4179M.....42T	11-4186M.....56T
11-4180M.....44T	11-4187M.....58T
11-4181M.....46T	11-4188M.....60T
11-4182M.....48T	11-4189M.....62T
11-4183M.....50T	11-4190M.....64T
11-4184M.....52T	11-4191M.....66T

BLUE (STYLE 7704T) TALL LENGTH

11-4212M.....40T	11-4219M.....54T
11-4213M.....42T	11-4220M.....56T
11-4214M.....44T	11-4221M.....58T
11-4215M.....46T	11-4222M.....60T
11-4216M.....48T	11-4223M.....62T
11-4217M.....50T	11-4224M.....64T
11-4218M.....52T	11-4225M.....66T

All Tall Sizes \$182.95



www.mercersmarine.com

- Always Open
- Sale & Feature items
- View Catalogue
- Thousands of products
- Updated Regularly
- Up to date Pricing
- Mobile Friendly
- Shop from anywhere at anytime

find us on

CLOTHING



PIONEER FLAME RESISTANT ZIP STYLE HOODIE

100% FR treated preshrunk cotton. Meets CGSB 155.20, 2000. Thermal Protective Performance (TPP) value: 12.0. Two front pouch pockets. Full brass zipper. Removable snap hood. New liberal sizing.

BLACK (STYLE 337)

11-3660M	XS	11-3665M	2X
11-3661M	Sm	11-3666M	3X
11-3662M	Med	11-3667M	4X
11-3663M	Lg	11-3668M	5X
11-3664M	XL		

All Sizes \$152.95

PIONEER FR COTTON LONG-SLEEVED T-SHIRT

100% FR treated preshrunk cotton. Meets CGSB 155.20, 2000. Thermal Protective Performance (TPP) value: 7.2. CSA Z96-15 Class 1 Level 2. FR 4" reflective tape. Self fabric crew neck. Chest pocket.

ORANGE STYLE 339SFA

11-3702M	Sm	11-3706M	2X
11-3703M	Med	11-3707M	3X
11-3704M	Lg	11-3708M	4X
11-3705M	XL	11-3709M	5X

BLACK STYLE 340SFA

11-3756M	Sm	11-3760M	2X
11-3757M	Med	11-3761M	3X
11-3758M	Lg	11-3762M	4X
11-3759M	XL	11-3763M	5X

All Sizes \$89.95

PIONEER FLAME RESISTANT ZIP STYLE HOODIE

100% FR treated preshrunk cotton. Meets CGSB 155.20, 2000. Thermal Protective Performance (TPP) value: 12.0. CSA Z96-15 Class 1 Level 2. FR 4" reflective tape. Two front pouch pockets. Full brass zipper. Removable snap hood. New liberal sizing.

ORANGE (STYLE 338SF)

11-3710M	XS	11-3715M	2X
11-3711M	Sm	11-3716M	3X
11-3712M	Med	11-3717M	4X
11-3713M	Lg	11-3718M	5X
11-3714M	XL		

BLACK (STYLE 337SF)

11-3772M	XS	11-3777M	2X
11-3773M	Sm	11-3778M	3X
11-3774M	Med	11-3779M	4X
11-3775M	Lg	11-3780M	5X
11-3776M	XL		

All Sizes \$179.95



NEW



NEW



Workwear

H/H FARGO 2.0 "FR" CREW NECK - 75091

Double knit cuffs. Antistatic. Highly resistant to abrasion. Moisture moving material. Flatlock seams.

13-139M.....	XS.....	159.95
13-140M.....	Sm.....	159.95
13-141M.....	Med.....	159.95
13-142M.....	Lg.....	159.95
13-143M.....	XL.....	159.95
13-144M.....	2X.....	159.95
13-145M.....	3X.....	159.95
13-146M.....	4X.....	159.95
13-147M.....	5X.....	159.95

H/H FARGO 2.0 "FR" PANT - 75491

Double knit cuffs. Antistatic. Highly resistant to abrasion. Moisture moving material. Flatlock seams.

13-148M.....	XS.....	159.95
13-149M.....	Sm.....	159.95
13-150M.....	Med.....	159.95
13-151M.....	Lg.....	159.95
13-152M.....	XL.....	159.95
13-153M.....	2X.....	159.95
13-154M.....	3X.....	159.95
13-155M.....	4X.....	159.95
13-156M.....	5X.....	159.95

H/H FARGO 2.0 "FR" BALACLAVA - 79896

Antistatic. Highly resistant to abrasion. Moisture moving material. Flatlock seams.

13-158M.....	44.95
--------------	-------



H/H FARGO 2.0 "FR" TOUQUE - 79898

Antistatic. Highly resistant to abrasion. Moisture moving material. Flatlock seams.

13-157M.....	Blue.....	44.95
--------------	-----------	-------



H/H FARGO 2.0 "FR" NECK GATER - 79897

Antistatic. Highly resistant to abrasion. Moisture moving material. Flatlock seams.

13-159M.....	39.95
--------------	-------





PIONEER FR QUILTED LONG NECK HARD HAT LINER (STYLE 564A)

100% FR treated 170g woven cotton shell. Meets CGSB 155.20, 2000. FR treated brushed cotton lining. Polyester filling. No mouthpiece. Helmet strap holes.
11-4058M.....One Size20.95



PIONEER FR QUILTED LONG NECK HARD HAT LINER (STYLE 566A)

100% FR treated cotton poplin quilted shell. Shell fabric meets CGSB 155.20, 2000. 100% cotton flannel lining. Detachable face piece.
11-4059M.....One Size24.95



PIONEER FR QUILTED LONG NECK HARD HAT LINER (STYLE 565A)

100% FR treated 170g woven cotton shell. Meets CGSB 155.20, 2000. FR treated brushed cotton lining. Polyester filling. Long neck with detachable mouthpiece.
11-4061M.....One Size28.95



PIONEER HEAVY-DUTY FR QUILTED LONG NECK HARD HAT LINER (STYLE 5565A)

100% FR treated 170g woven cotton shell. Meets CGSB 155.20, 2000. FR treated brushed cotton lining. Polyester filling. Long neck with detachable mouthpiece. Helmet secure straps.
11-4060M.....One Size44.95



PIONEER NOMEX® BALACLAVA (STYLE 666)

Nomex® III life-long flame resistant. 1 hole.
11-3725M.....One Size52.95



PIONEER NOMEX® NECK WARMER/WINDGUARD (STYLE C207BK)

Nomex® III life-long flame resistant
11-3726M.....One Size24.95



PIONEER FR COTTON LONG-SLEEVED T-SHIRT

100% FR treated preshrunk cotton knit. Meets CGSB 155.20, 2000. Thermal Protective Performance (TPP) value: 7.2. Left chest pocket. Crew collar neck. Comfort knit wrists.

STYLE 333

11-3781MSm 11-3785M2X
11-3782MMed 11-3786M3X
11-3783MLg 11-3787M4X
11-3784MXL 11-3788M5X

All Sizes \$68.95



**Shop or Browse
Online 24/7
at
mercersmarine.com**



PIONEER NOMEX® TOUQUE (STYLE C200)

Nomex® III life-long flame resistant
11-3724M.....One Size37.95



PIONEER NOMEX® BEANIE (STYLE C201)

Nomex® III life-long flame resistant
11-3723M.....One Size38.95



3M**3M HALF-MASK FACEPIECE**

This Mask from 3M includes new state-of-the-art features to provide unsurpassed comfort. A soft seal design with advanced silicone material provides a softer feel on the face, while a unique head harness design adjusts easily so the user has the option of wearing the respirator in either traditional or drop-down mode. The Cool-Flow Exhalation Valve makes breathing easier, and helps reduce heat and moisture build-up in the facepiece.

54-481R.....#7502 Med.....66.95
 54-482R..... #7503 Large.....66.95

3M**FACE MASK**

This half face mask is very comfortable and extremely light weight. Cartridges & filters are simply twisted on. Select your filter or cartridges to suit your needs. NIOSH/MSHA approved.

54-129R.....#6200 Med.....28.95
 54-149R.....#6300 Large.....28.95

3M**FULL FACE RESPIRATOR**

Soft and lightweight face piece with easy to adjust straps. No retainers or extra parts are required to attach filters, cartridges or dual air lines. NIOSH approved. Uses cartridges and filters on this page.

54-469R.....#6700 Small.....329.95
 54-470R.....#6800 Med.....329.95
 54-471R.....#6900 Large.....329.95
 54-472R.....Repl. Lens cover.....4.29

**3M COOL-FLOW RESPIRATOR**

A low profile, three panel respirator that conforms to a wide range of face sizes. Cool Flow Valve reduces breathing resistance with high comfort/feel on face.

54-486R.....#9211.....3.99 ea.

**3M PARTICULATE RESPIRATOR**

Certified as 95% efficient in removing solid and liquid particles. Removes nuisance level organic vapors and odors. 3M Cool Flow Exhalation Valve improves comfort and adjustable straps and face seal ring provide secure fit.

54-488R.....#8214.....16.95 ea.

3M**DUST MIST RESPIRATOR**

The #8210 half mask is NIOSH/MSHA approved. This mask is used for sanding fiberglass, cured paint, seam fillers.

54-134R.....#8210.....1.95 ea

3M**3M WELDERS RESPIRATOR FILTER**

NIOSG approved for environments containing certain oil and non-oil based particles. Nuisance level Organic Vapour relief.

54-489R.....#2097.....20.95

3M**3M RESPIRATOR CLEANING WIPES**

These individually wrapped wipes are designed especially for use with 3M full and half mask respirators. The alcohol-free formula cleans the respirators without any negative effect upon the facepiece materials. Sold individually but if you need 100 they come conveniently packaged in a dispenser style box that can be wall mounted for easy access.

54-484R.....#504.....1.09 ea.

**ORGANIC VAPOR CARTRIDGE**

Gives you protection against organic vapors occurring in the construction of fiberglass boats or repairs. Unit does not filter dust or mist. One pair required per mask.

54-130R.....#6001.....25.95 pr.

**3M GAS/VAPOR CARTRIDGE**

NIOSH approved against certain organic vapours, acid gases, ammonia, methylamine or formaldehyde. Use with 3M Half and Full Facepieces 6000 Series and 3M Half and Full Facepieces 7000 Series with bayonet style cartridge holders.

54-491R.....#6006.....28.50 pr.

3M**3M MULTI GAS/VAPOR CARTRIDGE**

NIOSH approved for protection against certain organic vapors, acid gases, ammonia, methylamine, formaldehyde and particulates. Swept-back design allows an enhanced field of view and comfort. Bayonet compatibility allows use with many 3M half and full facepiece designs.

54-494R.....#60926.....57.95/pr.

**PRE-FILTER (FOR USE WITH VAPOR UNIT)**

This unit gives you dust/mist protection when used with the #6001 vapor cartridge. You need to use a pre-filter retainer to hold the pre-filter in place. Each unit is sold separately.

54-131R.....Pre-filter #5P71.....4.50 ea
 54-132R.....Retainer #501.....4.75 ea

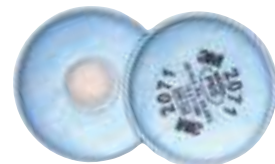
**3M DUST/MIST FILTER & ACC.**

This filter system gives you protection against dust & mist only when vapor protection is not needed. Units simply twist lock on to the face piece. 1 pr. required per mask.

54-133R.....#2071.....10.95 /pr

Workwear**CLOTHING**



3M

3M SAFETY GLASSES

Comfortable, lightweight frame features the Cord Control System (CCS) with foam gasket attachment. Meets the requirements of CSA Z94.3-07 and is Impact Rated to ANSI Z87.1-2010.

50-222M	Indoor/Outdoor	16.50
50-223M	Clear	16.50
50-224M	Grey	16.50
50-225M	Anti-Fog	25.95



SAFETY GLASSES (CSA APPROVED)

Super lightweight wraparound design for men and women. Rubberized temples provide additional comfort and traction. Impact resistant polycarbonate lens provide 99.9% UV protection and scratch resistant coating, optional anti-fog lenses are available. CSA Z94.3 certified and meets ANSI Z87.1.

50-217P	Clear Lens	2.19
50-218P	Indoor/Outdoor Lens	2.49
50-219P	Grey Lens	2.19



OTG (OVER THE GLASSES) CSA SAFETY GLASSES

Extra large size lens to fit the largest prescription spectacle. Extra soft adjustable nose piece that will accommodate all kinds of nose configurations. Adjustable temples giving you the possibility to adjust the lens up and down for better vision. Anti-fog, Anti-Scratch, Anti-UV, Anti-Static. New unique highly comfortable EZ-ON temple system. •CSA Z94.3-7 certified by CSA Canada and meets ANSI Z87.1 requirements.

50-363M	Clear	11.29
50-364M	Smoke	11.89
50-365M	Indoor/Outdoor	12.69



DYNAMIC EP850 SERIES SAFETY GLASSES

Z94.3-7 Certified by CSA Canada. Meets and/or exceeds ANSI Z87.1 requirements.

50-360M	Clear	4.89
50-361M	Smoke	5.49
50-362M	Indoor/Outdoor Lens	6.09

3M



3M EAR PLUGS

3M Ear Plugs provide comfortable and effective noise reduction with the convenience of disposability.

54-490R	#1100	0.28	pr.
---------	-------	------	-----

3M



3M EAR PLUGS

3M™ E-A-R™ Push-Ins™ earplugs provide all-day hearing comfort, convenience and protection. Constructed of 3M™ E-A-Rform™ foam, these earplugs feature a no roll-down design and a blue stem for a quick and easy fit.

54-496R	Model 318-1000	0.89
---------	----------------	------



3M

3M CORDED EAR PLUGS

Implanted stainless steel ball bearings aid in locating lost earplugs. Designed for food processing and other industries where it is critical to keep earplugs from contaminating products and processes. Paddle-style grips provide quick, clean, and consistent placement of earplugs. No-roll design keeps fingers, earplugs, and ears clean

54-497R	Model 311-1127	2.95
---------	----------------	------



HELLBERG NECK BAND EARMUFF S3

Made to tackle the ultimate noise scenarios. Supreme performance and protection without the sacrifice of comfort or practicality. The best choice for some of the highest noise levels workers are exposed to, especially effective against low frequencies. A perfect earmuff at airports, racetracks, and in the mining industry.

54-320M	58.95
---------	-------





DYNAMIC HARD HAT

Hard hat with rain trough HDPE shell foam liner 4-point - nylon suspension with "Sure-Lock" Ratchet adjustable suspension 4 anchor points for chin strap. Meets CSA Type 2 Class E and ANSI Type II Class E standards.

50-350K.....White	39.95	50-354K	Red	39.95
50-351K.....Yellow.....	39.95	50-355K.....Orange		39.95
50-352K.....Pink	39.95			



DYNAMIC HARD HAT

Full brim Hard hat with accessory slots. HDPE shell, foam liner, 6-point nylon suspension, "Sure-Lock" Ratchet adjustment, 4 anchor points for chin strap. Meets CSA Type 2 Class E and ANSI Type II Class E standards..

50-215K.....Orange	41.95
50-214K.....White	41.95
50-353K.....Yellow.....	41.95
50-216K.....Red.....	41.95



CAP MOUNT EARMUFF

This lightweight earmuff is designed for protection against high-level industrial noise and other loud sounds. A universal mounting attachment fits most hard hats. Stainless steel band construction resists bending and warping to offer consistent pressure over prolonged wearing periods. Earcup pivot points tilt for optimum comfort and efficiency. Noise Reduction Rating at 25 dB. CSA Class AL.

54-493R	Model X3P5E.....	45.95
---------------	------------------	-------



3M EARMUFF

High performance hearing protector for protection against high noise levels, for example forestry or heavy engineering. Twin headband design helps reduce heat buildup with good fit and balance. Slim-line, dual moulded cups for improved compatibility with other personal protective equipment. Electrically insulated wire headband.

54-495R	Model X3A	45.95
---------------	-----------------	-------



3M LOW PROFILE EAR MUFF

Lightweight, economical ear muff designed for comfort and durability in most work environments.

54-492R	H9A.....	38.95
---------------	----------	-------



PIONEER BIRDSEYE SAFETY T-SHIRT

Soft birdseye moisture-wicking polyester. CSA Z96-15 Class 2 Level 2. Combined-performance retroreflective tape. Rib crew neck. Chest pocket with hook and loop closure. Radiophone clip strap.

ORANGE (STYLE 6990)

11-4005M.....XS	11-4010M.....2X
11-4006M.....Sm	11-4011M.....3X
11-4007M.....Med	11-4012M.....4X
11-4008M.....Lg	11-4013M.....5X
11-4009M.....XL	

YELLOW (STYLE 6991)

11-3996M.....XS	11-4001M.....2X
11-3997M.....Sm	11-4002M.....3X
11-3998M.....Med	11-4003M.....4X
11-3999M.....Lg	11-4004M.....5X
11-4000M.....XL	

BLACK (STYLE 6992)

11-3987M.....XS	11-3992M.....2X
11-3988M.....Sm	11-3993M.....3X
11-3989M.....Med	11-3994M.....4X
11-3990M.....Lg	11-3995M.....5X
11-3991M.....XL	

All Sizes \$18.95

HI-VIZ TRAFFIC T-SHIRT

Micro mesh quick-dry. CSA Z96-15 Class 2 Level 2. 3M Scotchlite™ reflective tape. Chest pocket.

Short Sleeve

Orange (6979)

13-8015M.....Sm	24.95
13-8016M.....Med	24.95
13-8017M.....Lg	24.95
13-8018M.....XL	24.95
13-8019M.....2X	24.95
13-8020M.....3X	24.95

Yellow (6989)

13-8021M.....Sm	24.95
13-8022M.....Med	24.95
13-8023M.....Lg	24.95
13-8024M.....XL	24.95
13-8025M.....2X	24.95
13-8026M.....3X	24.95

LONG SLEEVE

Orange (6984)

13-8003M.....Sm	29.95
13-8004M.....Med	29.95
13-8005M.....Lg	29.95
13-8006M.....XL	29.95
13-8007M.....2X	29.95
13-8008M.....3X	29.95

Yellow (6985)

13-8009M.....Sm	29.95
13-8010M.....Med	29.95
13-8011M.....Lg	29.95
13-8012M.....XL	29.95
13-8013M.....2X	29.95
13-8014M.....3X	29.95



BIRDSEYE LONG-SLEEVED SAFETY T-SHIRT

Birdseye moisture-wicking polyester. CSA Z96-15 Class 1 Level 2. Combined-performance retroreflective tape. Rib crew neck. Chest pocket with hook and loop closure. Radiophone clip strap.

ORANGE (STYLE 6995)

11-4023M.....XS	11-4028M.....2X
11-4024M.....Sm	11-4029M.....3X
11-4025M.....Med	11-4030M.....4X
11-4026M.....Lg	11-4031M.....5X
11-4027M.....XL	

YELLOW (STYLE 6996)

11-4032M.....XS	11-4037M.....2X
11-4033M.....Sm	11-4038M.....3X
11-4034M.....Med	11-4039M.....4X
11-4035M.....Lg	11-4040M.....5X
11-4036M.....XL	

BLACK (STYLE 6997)

11-4014M.....XS	11-4019M.....2X
11-4015M.....Sm	11-4020M.....3X
11-4016M.....Med	11-4021M.....4X
11-4017M.....Lg	11-4022M.....5X
11-4018M.....XL	

All Sizes \$24.95





HI-VIZ TRAFFIC JACKET & PANT

Hi-viz polyester knit.CSA Z96-15 Class 2 Level 2 (Class 3 when worn together).3M Scotchlite™ reflective tape.

Jacket : 2-way brass zipper closure.Mesh ventilation panels on upper arms. Adjustable snap wrists.5 storage pockets: 2 chest, 2 front slash, 1 cell phone.

Pant : Brass zipper fly access.Mesh ventilation panels on upper legs.2-way leg zippers for ventilation and easy boot access.5 storage pockets: 2 side, 2 back, 1 tool. Elastic waist with drawstring.

Style 5999J Jacket

11-3816MXS	11-3820MXL
11-3817MSm	11-3821M2X
11-3818MMed	11-3822M3X
11-3819MLg	11-3823M4X

All Sizes \$49.95

Style 5999P Pant

11-3825MXS	11-3829MXL
11-3826MSm	11-3830M2X
11-3827MMed	11-3831M3X
11-3828MLg	11-3832M4X

All Sizes \$32.95

HI-VIZ TRAFFIC COVERALL

Hi-viz polyester knit.CSA Z96-15 Class 3 Level 2. 3M Scotchlite™ reflective tape. 2-way brass zipper closure.Mesh ventilation panels on upper arms and legs. 2-way leg zippers for ventilation and easy boot access.Adjustable snap wrists.7 storage pockets: 2 rear, 2 chest, 2 side, 1 tool.Hammer loop.2 pass-through pockets. Elastic waist. **STYLE 5999A**

11-3807MXS	11-3811MXL
11-3808MSm	11-3812M2X
11-3809MMed	11-3813M3X
11-3810MLg	11-3814M4X

All Sizes \$64.95



Want to receive e-mail updates from Mercer's Marine?
Subscribe at
mercersmarine.com





PIONEER OVERALLS

Poly/cotton. CSA Z96-09 Class 1, Level 2. 4" reflective tape. Zipper closure. Adjustable elastic suspenders. 7 storage pockets: 2 back, 2 chest, 2 side, 1 ruler. 2 pass-through pockets. Hammer loop.

REGULAR LENGTH (NAVY) Style 6615

Ord. No.	Size	Price
11-3531M	36R	78.95
11-3532M	38R	78.95
11-3533M	40R	78.95
11-3534M	42R	78.95
11-3535M	44R	78.95
11-3536M	46R	78.95
11-3537M	48R	78.95
11-3538M	50R	78.95
11-3539M	52R	78.95
11-3540M	54R	78.95
11-3541M	56R	78.95
11-3542M	58R	78.95
11-3543M	60R	78.95

REGULAR LENGTH (ORANGE) Style 6617

Ord. No.	Size	Price
13-8129M	36R	78.95
13-8130M	38R	78.95
13-8131M	40R	78.95
13-8132M	42R	78.95
13-8133M	44R	78.95
13-8134M	46R	78.95
13-8135M	48R	78.95
13-8136M	50R	78.95
13-8137M	52R	78.95
13-8138M	54R	78.95
13-8139M	56R	78.95
13-8140M	58R	78.95
13-8141M	60R	78.95

TALL LENGTH (NAVY) Style 6615T

11-3544M	40T	85.95
11-3545M	42T	85.95
11-3546M	44T	85.95
11-3547M	46T	85.95
11-3548M	48T	85.95
11-3549M	50T	85.95
11-3550M	52T	85.95
11-3551M	54T	85.95
11-3552M	56T	85.95
11-3553M	58T	85.95
11-3554M	60T	85.95

TALL LENGTH (ORANGE) Style 6617T

13-8142M	40T	85.95
13-8143M	42T	85.95
13-8144M	44T	85.95
13-8145M	46T	85.95
13-8146M	48T	85.95
13-8147M	50T	85.95
13-8148M	52T	85.95
13-8149M	54T	85.95
13-8150M	56T	85.95
13-8151M	58T	85.95
13-8152M	60T	85.95

DISPOSABLE COVERALLS

- Microporous film laminate
- Breathable, comfortable and lint free
- Protects from dirt, grime and liquid splashes as well as from paints, bleach and blood
- Zipper front
- Improved hood and neck design reduces leakage points
- Designed with elastic waist, ankles and wrists for optimum fit and freedom of movement
- Serged seams
- For non-hazardous environment applications

WHITE

52-792R	Sm	7.95
52-793R	Med	7.95
52-794R	Lg	7.95
52-795R	XL	7.95
52-796R	2X	7.95
52-797R	3X	7.95
52-798R	4X	7.95
52-799R	5X	7.95





PIONEER COVERALLS

7 oz (230 GSM) poly/cotton. StarTech reflective tape. 2-way heavy-duty brass zipper. Adjustable snap wrists. 7 storage pockets: 2 back, 2 chest, 2 side, 1 tool. 2 pass-through pockets. All pockets and key stress points bartacked for strength. Action back and elastic waist. Model 5516 Class 1 Level 2. Model 5514 Class 3 Level 2.

REG LENGTH (NAVY) 5516

11-3501M36 Reg.....	80.95
11-3502M38 Reg.....	80.95
11-3503M40 Reg.....	80.95
11-3504M42 Reg.....	80.95
11-3505M44 Reg.....	80.95
11-3506M46 Reg.....	80.95
11-3507M48 Reg.....	80.95
11-3508M50 Reg.....	80.95
11-3509M52 Reg.....	80.95
11-3510M54 Reg.....	80.95
11-3511M56 Reg.....	80.95
11-3512M58 Reg.....	80.95
11-3513M60 Reg.....	80.95

REG LENGTH (ORANGE) 5514

13-8033M36 Reg.....	80.95
13-8034M38 Reg.....	80.95
13-8035M40 Reg.....	80.95
13-8036M42 Reg.....	80.95
13-8037M44 Reg.....	80.95
13-8038M46 Reg.....	80.95
13-8039M48 Reg.....	80.95
13-8040M50 Reg.....	80.95
13-8041M52 Reg.....	80.95
13-8042M54 Reg.....	80.95
13-8043M56 Reg.....	80.95
13-8044M58 Reg.....	80.95
13-8045M60 Reg.....	80.95

TALL LENGTH (NAVY) 5516T

11-3516M40 Tall.....	88.95
11-3517M42 Tall.....	88.95
11-3518M44 Tall.....	88.95
11-3519M46 Tall.....	88.95
11-3520M48 Tall.....	88.95
11-3521M50 Tall.....	88.95
11-3522M52 Tall.....	88.95
11-3523M54 Tall.....	88.95
11-3524M56 Tall.....	88.95
11-3525M58 Tall.....	88.95
11-3526M60 Tall.....	88.95

TALL LENGTH (ORANGE) 5514T

13-8046M40 Tall.....	88.95
13-8047M42 Tall.....	88.95
13-8048M44 Tall.....	88.95
13-8049M46 Tall.....	88.95
13-8050M48 Tall.....	88.95
13-8051M50 Tall.....	88.95
13-8052M52 Tall.....	88.95
13-8053M54 Tall.....	88.95
13-8054M56 Tall.....	88.95
13-8055M58 Tall.....	88.95
13-8056M60 Tall.....	88.95

PIONEER COVERALLS WITH LEG ZIPPER

7 oz (240 GSM) poly/cotton. Suitable for industrial wash. CSA Z96-15 Class 3 Level 2. Double-stitched StarTech reflective tape. 2-way heavy-duty brass zipper. 18" brass leg zippers for easy boot access. Adjustable snap wrists. 7 storage pockets: 2 back, 2 chest, 2 side, 1 tool. 2 pass-through pockets. All pockets and key stress points bar-tacked for strength. Action back. Elastic on the back, on either side of waistband. UPF 50+ UV protection.

REG LENGTH (ORANGE) 5513

13-8066M36 Reg.....	96.95
13-8067M38 Reg.....	96.95
13-8068M40 Reg.....	96.95
13-8069M42 Reg.....	96.95
13-8070M44 Reg.....	96.95
13-8071M46 Reg.....	96.95
13-8072M48 Reg.....	96.95
13-8073M50 Reg.....	96.95
13-8074M52 Reg.....	96.95
13-8075M54 Reg.....	96.95
13-8076M56 Reg.....	96.95
13-8077M58 Reg.....	96.95
13-8078M60 Reg.....	96.95

TALL LENGTH (ORANGE) 5513T

13-8082M40 Tall.....	102.95
13-8083M42 Tall.....	102.95
13-8084M44 Tall.....	102.95
13-8085M46 Tall.....	102.95
13-8086M48 Tall.....	102.95
13-8087M50 Tall.....	102.95
13-8088M52 Tall.....	102.95
13-8089M54 Tall.....	102.95
13-8090M56 Tall.....	102.95
13-8091M58 Tall.....	102.95
13-8092M60 Tall.....	102.95



Replacement Hood Available

Replacement Hood Available



- Always Open
- Sale & Feature items
- View Catalogue
- Thousands of products
- Updated regularly
- Up to date pricing
- Mobile friendly
- Shop from anywhere at anytime

www.mercersmarine.com

PIONEER QUILTED COTTON DUCK COVERALLS

100% cotton duck canvas, 10.5 oz (350 GSM) with 6.5 oz (220 GSM) poly filling. CSA Z96-15 Class 1 Level 2. Double-stitched StarTech reflective tape with combined-performance trim. 2-way brass zipper. Radiophone clip strap. 6 storage pockets: 2 back, 2 chest, 2 front. Elastic waist, foot straps and wrists. Hip-to-ankle brass zipper on each side. Hammer loop.

Style 5539A Navy

11-4078MSm	11-4082M2X
11-4079MMed	11-4083M3X
11-4080MLg	11-4084M4X
11-4081MXL	

All Sizes \$182.95

Style 5540A Orange

11-4085MSm	11-4089M2X
11-4086MMed	11-4090M3X
11-4087MLg	11-4091M4X
11-4088MXL	

All Sizes \$182.95

11-4142MReplacement Navy Hood.....14.95

11-4144M.....Replacement Orange Hood.....14.95



Also find us on





Big Al, Canadian Made Coveralls.
65% polyester / 35% cotton



Workwear

BIG AL UNLINED COVERALLS

Two front chest pockets, left with pencil slot, right with flap and dome closure. Two front swing pockets. Side opening to trousers. Concealed front zipper. Reinforced at points of strain. Two hip pockets. Full fit. 65% POLYESTER / 35% COTTON. Canadian made.

NAVY (REGULAR) STYLE 1445

Ord. No.	Size	Price
12-389M	36R	72.50
12-390M	38R	72.50
12-391M	40R	72.50
12-392M	42R	72.50
12-393M	44R	72.50
12-394M	46R	72.50
12-395M	48R	82.95
12-396M	50R	82.95
12-397M	52R	82.95
12-398M	54R	95.95
12-1381M	56R	95.95
12-1382M	58R	109.95
12-1383M	60R	109.95
12-7251M	62R	126.50
12-7252M	64R	126.50

NAVY (REGULAR) STLYE 1425

Ord. No.	Size	Price
12-7134M	36R	55.95
12-7135M	38R	55.95
12-7136M	40R	55.95
12-7137M	42R	55.95
12-7138M	44R	55.95
12-7139M	46R	55.95
12-7140M	48R	63.95
12-7141M	50R	63.95
12-7142M	52R	63.95
12-7143M	54R	73.50
12-7144M	56R	73.50
12-7145M	58R	84.50
12-7146M	60R	84.50
12-7247M	62R	96.95
12-7248M	64R	96.95

NAVY (REGULAR) STYLE 1345 WITH LEG ZIPPER

Ord. No.	Size	Price
12-7030M	36R	83.95
12-7031M	38R	83.95
12-7032M	40R	83.95
12-7033M	42R	83.95
12-7034M	44R	83.95
12-7035M	46R	83.95
12-7036M	48R	96.50
12-7037M	50R	96.50
12-7038M	52R	96.50
12-7039M	54R	110.95
12-7040M	56R	110.95
12-7041M	58R	127.50
12-7042M	60R	127.50

NAVY (TALL) STYLE 1445T

12-399M	38T	79.95
12-400M	40T	79.95
12-401M	42T	79.95
12-402M	44T	79.95
12-403M	46T	79.95
12-404M	48T	91.50
12-405M	50T	91.50
12-406M	52T	91.50
12-407M	54T	104.95
12-408M	56T	104.95
12-409M	58T	120.95
12-410M	60T	120.95
12-7253M	62T	139.50
12-7254M	64T	139.50

NAVY (TALL) STYLE 1425T

12-7148M	38T	60.95
12-7149M	40T	60.95
12-7150M	42T	60.95
12-7151M	44T	60.95
12-7152M	46T	60.95
12-7153M	48T	69.95
12-7154M	50T	69.95
12-7155M	52T	69.95
12-7156M	54T	80.95
12-7157M	56T	80.95
12-7158M	58T	92.95
12-7159M	60T	92.95
12-7249M	62T	106.95
12-7250M	64T	106.95

NAVY (TALL) STYLE 1345T

12-7045M	42T	91.95
12-7046M	44T	91.95
12-7047M	46T	91.95
12-7048M	48T	105.95
12-7049M	50T	105.95
12-7050M	52T	105.95
12-7051M	54T	121.95
12-7052M	56T	121.95
12-7053M	58T	140.50
12-7054M	60T	140.50

Prices are subject to change. Check our website for up to date prices. www.mercersmarine.com





MADE IN CANADA



MADE IN CANADA



INSULATED COVERALLS

Quality Canadian-made insulated coverall of 65% polyester, 35% cotton. Lining is quilted nylon with polyester fill. Two front chest pockets, two front swing pockets, side opening to trousers. Two hip pockets, zippered front and reinforced at all points of strain.

NAVY BLUE (REGULAR) STYLE 1450

12-433MSm / Reg.162.95
12-434MMed / Reg.162.95
12-435MLg / Reg.162.95
12-436MXL / Reg.162.95
12-437M2XL / Reg.186.95
12-438M3XL / Reg.186.95
12-333M4XL / Reg.214.95
12-334M5XL / Reg.246.95

NAVY BLUE (TALL) STYLE 1450T

12-439MMed / Tall178.95
12-440MLg / Tall178.95
12-441MXL / Tall178.95
12-442M2XL / Tall205.50
12-443M3XL / Tall205.50
12-335M4XL / Tall236.50
12-336M5XL / Tall271.95

CAMOUFLAGE (REGULAR) STYLE 1457

12-2636MSm / R.201.95
12-2637MMed / R.201.95
12-2638MLg / R.201.95
12-2639MXL / R.201.95
12-2640M2XL / R.231.50
12-2641M3XL / R.231.50

CAMOUFLAGE (TALL) STYLE 1457T

12-2642MMed / T.221.95
12-2643MLg / T.221.95
12-2644MXL / T.221.95
12-2645M2XL / T.254.95
12-2646M3XL / T.254.95

BIG AL UNLINED CAMOUFLAGE COVERALLS

Two front chest pockets, left with pencil slot, right with flap and dome closure •Two front swing pockets •Side opening to trousers •Concealed front zipper •Reinforced at points of strain •Two hip pockets •Full fit •65% POLYESTER / 35% COTTON •Canadian made.

CAMOUFLAGE (REGULAR) STYLE 1447

Ord. No.	Size	Price
12-2534M36R91.95
12-2535M38R91.95
12-2536M40R91.95
12-2537M42R91.95
12-2538M44R91.95
12-2539M46R91.95
12-2540M48R105.95
12-2541M50R105.95
12-2542M52R105.95
12-2543M54R121.95
12-2544M56R121.95
12-2545M58R140.50
12-2546M60R140.50

CAMOUFLAGE (TALL) 1447T

12-2547M38T101.50
12-2548M40T101.50
12-2549M42T101.50
12-2550M44T101.50
12-2551M46T101.50
12-2552M48T116.95
12-2553M50T116.95
12-2554M52T116.95
12-2555M54T134.50
12-2556M56T134.50
12-2557M58T154.50
12-2558M60T154.50

find us on our social media pages

See what's going on, sales, promotions, news & much more.

KIDS

Distributed Exclusively in NL by



Workwear



MADE IN CANADA



KIDS UNLINED COVERALLS

Two front chest pockets. Two front swing pockets. Concealed front zipper. Reinforced at points of strain. Two hip pockets. Two rear pockets. Full fit. 65% POLYESTER / 35% COTTON. Canadian made.

NAVY (CHILDS)

12-6957M.....2.....	43.95
12-6958M.....4.....	43.95
12-6959M.....6.....	43.95
12-6960M.....6X.....	43.95

NAVY (YOUTHS)

12-6961M.....8.....	47.95
12-6962M.....10.....	47.95
12-6963M.....12.....	47.95
12-6964M.....14.....	47.95
12-6965M.....16.....	47.95
12-6966M.....18.....	47.95

ORANGE (CHILDS)

12-7017M.....2.....	43.95
12-7018M.....4.....	43.95
12-7019M.....6.....	43.95
12-7020M.....6X.....	43.95

ORANGE (YOUTHS)

12-7021M.....8.....	47.50
12-7022M.....10.....	47.50
12-7023M.....12.....	47.50
12-7024M.....14.....	47.50
12-7025M.....16.....	47.50
12-7026M.....18.....	47.50

CAMO (CHILDS)

12-6967M.....2.....	64.95
12-6968M.....4.....	64.95
12-6969M.....6.....	64.95
12-6970M.....6X.....	64.95

CAMO (YOUTHS)

12-6971M.....8.....	70.95
12-6972M.....10.....	70.95
12-6973M.....12.....	70.95
12-6974M.....14.....	70.95
12-6975M.....16.....	70.95
12-6976M.....18.....	70.95

NAVY WITH YELLOW STRIPE (CHILDS)

12-7200M.....2.....	68.50
12-7201M.....4.....	68.50
12-7202M.....6.....	68.50
12-7203M.....6X.....	68.50

NAVY (YOUTHS)

12-7204M.....8.....	73.95
12-7205M.....10.....	73.95
12-7206M.....12.....	73.95
12-7207M.....14.....	73.95
12-7208M.....16.....	73.95
12-7209M.....18.....	73.95

PINK (CHILDS)

12-7007M.....2.....	43.95
12-7008M.....4.....	43.95
12-7009M.....6.....	43.95
12-7010M.....6X.....	43.95

PINK (YOUTHS)

12-7011M.....8.....	47.50
12-7012M.....10.....	47.50
12-7013M.....12.....	47.50
12-7014M.....14.....	47.50
12-7015M.....16.....	47.50
12-7016M.....18.....	47.50



CAMO/PINK (CHILDS)

12-7210M.....2.....	56.95
12-7211M.....4.....	56.95
12-7212M.....6.....	56.95
12-7213M.....6X.....	56.95

CAMO/PINK (YOUTHS)

12-7214M.....8.....	61.50
12-7215M.....10.....	61.50
12-7216M.....12.....	61.50
12-7217M.....14.....	61.50
12-7218M.....16.....	61.50
12-7219M.....18.....	61.50

CAMO/BLUE (CHILDS)

12-6440M.....2.....	56.95
12-6441M.....4.....	56.95
12-6442M.....6.....	56.95
12-6443M.....6X.....	56.95

CAMO BLUE (YOUTHS)

12-6444M.....8.....	61.50
12-6445M.....10.....	61.50
12-6446M.....12.....	61.50
12-6447M.....14.....	61.50
12-6448M.....16.....	61.50
12-6449M.....18.....	61.50

Prices are subject to change. Check our website for up to date prices. www.mercersmarine.com

CLOTHING



351



INSULATED
KIDS



MADE IN
CANADA 



KIDS INSULATED COVERALLS

Quality Canadian-made insulated coverall of 65% polyester, 35% cotton. Lining is quilted nylon with polyester fill. Two front chest pockets, two front swing pockets, side opening to trousers. Two hip pockets, zippered front and reinforced at all points of strain.

NAVY (CHILDS)

12-6400M2.....	90.95
12-6401M4.....	90.95
12-6402M6.....	90.95
12-6403M6X.....	90.95

NAVY (YOUTHS)

12-6404M8.....	98.95
12-6405M10.....	98.95
12-6406M12.....	98.95
12-6407M14.....	98.95
12-6408M16.....	98.95
12-6409M18.....	98.95

CAMO (CHILDS)

12-6410M2.....	108.95
12-6411M4.....	108.95
12-6412M6.....	108.95
12-6413M6X.....	108.95

CAMO (YOUTHS)

12-6414M8.....	116.95
12-6415M10.....	116.95
12-6416M12.....	116.95
12-6417M14.....	116.95
12-6418M16.....	116.95
12-6419M18.....	116.95

CAMO/PINK (CHILDS)

12-6420M2.....	94.50
12-6421M4.....	94.50
12-6422M6.....	94.50
12-6423M6X.....	94.50

CAMO/PINK (YOUTHS)

12-6424M8.....	101.95
12-6425M10.....	101.95
12-6426M12.....	101.95
12-6427M14.....	101.95
12-6428M16.....	101.95
12-6429M18.....	101.95



"LITTLE KIDS" WORK GLOVES

Just like mom & dad's! Kids love this item.

16-070MSm.....	9.29
16-071MMed.....	9.29

KIDS COVERALLS

AVAILABLE ON OUR
WEBSITE AT
WWW.MERCERSMARINE.COM





Workwear

BIG BILL "UNLINED" COVERALLS

7.5 oz. Twill 65% polyester fiber, 35% cotton precured. 3M™ 3/4" reflective tape : 1 horizontal around each arm and leg, 2 vertical on front from shoulder to waistband and with "X" on the back. Long life "Vat" dye. Long sleeves with snap closure on cuffs. 2 chest pockets (pencil division on left pocket). Flaps on chest pockets. 2 front pockets. Sides opening. 2 snaps closures on collar. Front with two way brass zipper closure. Double stitches on waistband with elastic on back. Telescopic back for comfort. 2 big rear patch pockets. 1 tool pocket on right leg. Hammer loop on left and right leg. High resistance thread. Bar-tacks at all stress points.

REGULAR LENGTH Style 439BF - NAVY

Ord. No.	Size	Price
13-8626M	36R	186.95
13-8627M	38R	186.95
13-8628M	40R	186.95
13-8629M	42R	186.95
13-8630M	44R	186.95
13-8631M	46R	186.95
13-8632M	48R	214.50
13-8633M	50R	214.50
13-8634M	52R	214.50
13-8635M	54R	214.50
13-8636M	56R	214.50
13-8637M	58R	214.50
13-8638M	60R	214.50

TALL LENGTH Style 439BFT

13-8643M	40T	204.95
13-8644M	42T	204.95
13-8645M	44T	204.95
13-8646M	46T	204.95
13-8647M	48T	232.95
13-8648M	50T	232.95
13-8649M	52T	232.95
13-8650M	54T	232.95
13-8651M	56T	232.95
13-8652M	58T	232.95
13-8653M	60T	232.95

BIG BILL "UNLINED" COVERALLS

7.5 oz. Twill 65% polyester fiber, 35% cotton, precured. Long life "Vat" dye. Long sleeves with snap closure on cuffs. 2 chest pockets (pencil division on left pocket). Flap on right chest pocket. 2 front pockets. Side openings. 2 Big Bill® snaps on collar. 2-way brass zipper front closure. Double stitches on waistband with elastic on back. Telescopic back for comfort. 2 big rear pockets. 1 tool pocket on right leg. Hammer loop on left leg. High resistance thread. Bar-tacked at all stress points.

REGULAR LENGTH Style 429R - NAVY

Ord. No.	Size	Price
13-8600M	36R	98.95
13-8601M	38R	98.95
13-8602M	40R	98.95
13-8603M	42R	98.95
13-8604M	44R	98.95
13-8605M	46R	98.95
13-8606M	48R	114.50
13-8607M	50R	114.50
13-8608M	52R	114.50
13-8609M	54R	114.50
13-8610M	56R	114.50
13-8611M	58R	114.50
13-8612M	60R	114.50

TALL LENGTH Style 429T

13-8615M	40T	109.50
13-8616M	42T	109.50
13-8617M	44T	109.50
13-8618M	46T	109.50
13-8619M	48T	123.95
13-8620M	50T	123.95
13-8621M	52T	123.95
13-8622M	54T	123.95
13-8623M	56T	123.95
13-8624M	58T	123.95
13-8625M	60T	123.95

BIG BILL "INSULATED" COVERALLS

7.5 oz. Twill, 65% polyester fiber, 35% cotton, precured. 3M™ 3/4" #9920 reflective tape center stitched over 2 1/4" Enhanced visibility trim emplacement : 1 horizontal around each arm and leg. Long life "Vat" dye. 4 oz. 100% polyester fill lining. 2-way zipper front closure with 2 snaps on collar. 2 big chest pockets with brass zipper closure (pencil division on left). Double stitches on waistband. 2 front pockets. Side openings. Zipper closures on legs. Telescopic back for comfort. 2 big rear pockets. High resistance thread. Bar-tacked at all stress points.

REGULAR LENGTH Style 837BF - NAVY

Ord. No.	Size	Price
13-9500M	Sm	274.95
13-9501M	Med	274.95
13-9502M	Lg	274.95
13-9503M	XL	274.95
13-9504M	2X	316.50
13-9505M	3X	316.50
13-9506M	4X	316.50
13-9507M	5X	316.50

TALL LENGTH Style 837BFT

13-9508M	Med	302.95
13-9509M	Lg	302.95
13-9510M	XL	302.95
13-9511M	2X	343.95
13-9512M	3X	343.95
13-9513M	4X	343.95
13-9514M	5X	343.95



Orange Available by Special Order. Pricing same as Navy. Please Inquire.

Hammill

65% Polyester / 35% Cotton,
Quality since 1929.



HAMMILL UNLINED COVERALLS

65% polyester/ 35% cotton twill. Perma press and washable. Self locking two way brass zipper. Two breast pockets c/w pencil slot. Two lower front pockets. Side access openings. Two back pockets. Elastic in back of waistband. Domes with antique brass.

REGULAR LENGTH (Dark Blue) M210R

12-4025M	36R	82.95
12-4026M	38R	82.95
12-4027M	40R	82.95
12-4028M	42R	82.95
12-4029M	44R	82.95
12-4030M	46R	82.95
12-4031M	48R	94.95
12-4032M	50R	94.95
12-4033M	52R	94.95
12-4034M	54R	94.95
12-4035M	56R	94.95

TALL SIZES (DARK BLUE) M210T

12-4038M	38T	90.95
12-4039M	40T	90.95
12-4040M	42T	90.95
12-4041M	44T	90.95
12-4042M	46T	90.95
12-4043M	48T	102.95
12-4044M	50T	102.95
12-4045M	52T	102.95
12-4046M	54T	102.95
12-4047M	56T	102.95



100% Cotton



BIG AL UNLINED COVERALLS

NAVY – 100% COTTON

Two front chest pockets, left with pencil slot, right with flap & dome closure. Two front swing pockets. Side opening to trousers. Front snap closure. Reinforced at points of strain. Two hip pockets. Full fit. Canadian made.

REGULAR LENGTH (NAVY) STYLE 1448

12-1356M	36R	89.95
12-1357M	38R	89.95
12-1358M	40R	89.95
12-1359M	42R	89.95
12-1360M	44R	89.95
12-1361M	46R	89.95
12-1362M	48R	103.50
12-1363M	50R	103.50
12-1364M	52R	103.50
12-1365M	54R	119.95
12-1366M	56R	119.95
12-1367M	58R	136.95
12-1368M	60R	136.95

TALL SIZES (NAVY) STYLE 1448T

12-1369M	38T	98.95
12-1370M	40T	98.95
12-1371M	42T	98.95
12-1372M	44T	98.95
12-1373M	46T	98.95
12-1374M	48T	113.95
12-1375M	50T	113.95
12-1376M	52T	113.95
12-1377M	54T	130.95
12-1378M	56T	130.95
12-1379M	58T	150.95
12-1380M	60T	150.95



MADE IN CANADA

BIG-AL "LADIES" UNLINED COVERALL

Two front chest pockets with flap and dome closure. 2 Rear pockets. Concealed front zipper. Reinforced at points of strain. Two hip pockets. Elastic sides. 65% POLYESTER / 35% COTTON. Canadian made.

STYLE 5000

12-074M	XS	74.95
12-075M	Sm	74.95
12-076M	Med	74.95
12-077M	Lg	74.95
12-078M	XL	74.95
12-079M	2X	86.50
12-080M	3X	86.50



**Shop or Browse
Online 24/7
at
mercersmarine.com**





BIG AL SHOP COATS

65% Polyester / 35% Cotton. Permanent press, snap front. One chest patch pocket with pencil holder. 2 large front patch pockets. 2 side concealed/slash openings, center back vent, reinforced at all points of strain.

NAVY

12-7189M	36	64.95
12-7190M	38	64.95
12-7191M	40	64.95
12-7192M	42	64.95
12-7193M	44	64.95
12-7194M	46	74.50
12-7195M	48	74.50
12-7196M	50	74.50
12-7197M	52	85.50
12-7198M	54	85.50
12-7199M	56	85.50



TOUGH-DUCK STRETCH TWILL CARGO PANT

Cargo Work Pant. 98% cotton, 2% lycra stretch twill. Pockets & trim reinforced with Cordura. Multi-pocket design. Revets at all stress points. Model 6010.

NAVY

13-1393M	30 x 32	64.95
13-1394M	32 x 32	64.95
13-1395M	34 x 32	64.95
13-1396M	36 x 32	64.95
13-1397M	38 x 32	64.95
13-1398M	40 x 32	64.95
13-1399M	42 x 32	64.95
13-1400M	44 x 32	64.95

BLACK

13-1490M	28 x 30	64.95
13-1491M	30 x 30	64.95
13-1492M	32 x 30	64.95
13-1493M	34 x 30	64.95
13-1494M	36 x 30	64.95
13-1495M	38 x 30	64.95
13-1496M	40 x 30	64.95
13-1497M	42 x 30	64.95
13-149M	44 x 30	64.95

BLACK

13-1401M	30 x 32	64.95
13-1402M	32 x 32	64.95
13-1403M	34 x 32	64.95
13-1404M	36 x 32	64.95
13-1405M	38 x 32	64.95
13-1406M	40 x 32	64.95
13-1407M	42 x 32	64.95
13-1408M	44 x 32	64.95

BLACK

13-1500M	32 x 34	64.95
13-1501M	34 x 34	64.95
13-1502M	36 x 34	64.95
13-1503M	38 x 34	64.95
13-1504M	40 x 34	64.95
13-1505M	42 x 34	64.95
13-1506M	44 x 34	64.95



TOUGH-DUCK CARGO SHORTS

Cool and convenient. The Flex Twill blend gives you maximum comfort while the multiple reinforced pockets keep everything you need close at hand. Reinforced pockets and a gusseted crotch, a zipper fly and riveted stress points alongside triple-stitched durability. 98% cotton, 2% Spandex Flex Twill blend. Stain repellent finish. Triple stitched.

NAVY

13-1337M	30	48.95
13-1338M	32	48.95
13-1339M	34	48.95
13-1340M	36	48.95
13-1341M	38	48.95
13-1342M	40	48.95
13-1343M	42	48.95
13-1344M	44	48.95

BLACK

13-1345M	30	48.95
13-1346M	32	48.95
13-1347M	34	48.95
13-1348M	36	48.95
13-1349M	38	48.95
13-1350M	40	48.95
13-1351M	42	48.95
13-1352M	44	48.95



GENUINE LEATHER BELTS

Heavy duty leather belts. For work or leisure. 1 1/4" width.

13-7010K	28	49.95
13-7011K	30	49.95
13-7012K	32	49.95
13-7013K	34	49.95
13-7014K	36	49.95
13-7015K	38	49.95
13-7016K	40	49.95
13-7017K	42	49.95
13-7018K	44	49.95
13-7019K	46	49.95



ELASTIC SUSPENDERS

2" Heavy duty elastic suspenders. Made in Newfoundland. Exceptional Quality. Button Hole model shown. (Note: Snap model loops over belt. Clasp model clips to pant.)

13-7035K	With Clasp	31.95
13-7036K	With Button Hole	31.95
13-7037K	With Snap	31.95



TOUGH-DUCK WORK GLOVE

10 oz. cotton brown twill. Palm lined. Premium cowhide. Rubberized safety cuff. Leather knuckle strap and finger tips.

13-7874M.....	Med	19.95
13-7875M.....	Lg	19.95
13-7876M.....	XL	19.95
13-7877M	2X	19.95



FIV CHAIN SAW PANTS

BNQ certified No.556. UL Classified. Made in Canada. CAN/BNQ 1923-450-M91 Class A -8F67.

12-1035K	28	175.95
12-1036K	30	175.95
12-1037K	32	175.95
12-1038K	34	175.95
12-1039K	36	175.95
12-1040K	38	175.95
12-1041K	40	175.95
12-1042K	42	175.95
12-1043K	44	175.95
12-1044K	46	211.95
12-1045K	48	211.95
12-1046K	50	219.95
12-1047K	52	219.95



INSULATED FITTERS COWGRAIN GLOVE

One-piece palm. Fully fleece lined. Knit cuff.

16-086P.....	One Size	12.49
--------------	----------------	-------



ENDURA CHAINSAW GLOVES

Comfortable and highly dexterous. Back of left hand is lined with eight layers of chain-arrest woven Kevlar to stop a chainsaw running at 3140 feet per minute. Highly abrasion-resistant goatskin leather palms. Elasticized Velcro wrists provide snug fit and keep out debris. Hi-viz backs are designed for optimal visibility. Nylon backings feature water-resistant membrane to keep hands dry.

16-019M.....	Med	43.95/pr.
16-020M.....	Lg	43.95/pr.
16-021M.....	XL	43.95/pr.



PIONEER COWGRAIN WORK GLOVE

One-piece palm. Inside elastic, rubberized cuff.

16-1006M.....	One Size	7.79
---------------	----------------	------

CHAIN SAW SAFETY CHAPS

6 ply Kevlar protection. 600 Denier Nylon. Front and back protection. Integrated belt, plastic buckle.

12-1053K.....	Green - One Size	210.95
12-1054K	Orange - One Size	215.95



JACKFIELD



JACKFIELD



Workwear

POLAR FLEECE SHIRT

100% polyester. Regular plastic button closure at the front. Cuffs with plastic button adjustment. Two chest pockets. Long sleeves.

Red		Blue	
11-100M.....	Sm	11-108M.....	Sm
11-101M.....	Med	11-109M.....	Med
11-102M.....	Lg	11-110M.....	Lg
11-103M.....	XL	11-111M.....	XL
11-104M.....	2X	11-112M.....	2X
11-105M.....	3X	11-113M.....	3X
11-106M.....	4X	11-114M.....	4X

QUILTED FLANNEL SHIRT

100% cotton. Insulated with 9 oz, 100% polyester, interlined with 100% nylon facing. Front closure with rustproof snaps. Cuffs with rustproof snap adjustments. Two chest pockets with flap and rustproof snap closure. Two waist pockets. Long sleeves.

Red		Blue	
11-132M.....	Sm	11-141M.....	Sm
11-133M.....	Med	11-142M.....	Med
11-134M.....	Lg	11-143M.....	Lg
11-135M.....	XL	11-144M.....	XL
11-136M.....	2X	11-145M.....	2X
11-137M.....	3X	11-146M.....	3X
11-138M.....	4X	11-147M.....	4X

JACKFIELD



QUILTED FLANNEL SHIRT WITH HOOD

100% cotton. Insulated with 9 oz, 100% polyester, interlined with 100% nylon facing. Hood made of polar fleece 100% polyester. Front closure with rustproof snaps and zipper. Cuffs with double rustproof snap adjustments. Two chest pockets with flap and rustproof snap closure. Two waist pockets. Long sleeves.

Red		Blue	
11-149M.....	Sm	11-157M.....	Sm
11-150M.....	Med	11-158M.....	Med
11-151M.....	Lg	11-159M.....	Lg
11-152M.....	XL	11-160M.....	XL
11-153M.....	2X	11-161M.....	2X
11-154M.....	3X	11-162M.....	3X
11-155M.....	4X	11-163M.....	4X
11-156M.....	5X	11-164M.....	5X

Prices are subject to change. Check our website for up to date prices. www.mercersmarine.com

CLOTHING



POLAR FLEECE SHIRT LINED WITH SHERPA

100% polyester. 100% acrylic sherpa lining. Regular plastic button closure at the front. Cuffs with plastic button adjustment. Two chest pockets. Long sleeves.

Red		
11-116M	Sm	71.95
11-117M	Med	71.95
11-118M	Lg	71.95
11-119M	XL	71.95
11-120M	2X	83.95
11-121M	3X	83.95
11-122M	4X	83.95

QUILTED LUMBERJACK JACKET

Quilted lining.

Red		
13-23071M	XS	64.95
13-23072M	Sm	64.95
13-23073M	Med	64.95
13-23074M	Lg	64.95
13-23075M	XL	64.95
13-23076M	2X	64.95
13-23077M	3X	64.95

PLAID SOLAR FLEECE SHIRT

Shell: 100% Polyester heavy weight solar fleece. Button front closures. 2 chest pockets with button closures. Adjustable cuffs.

Red Plaid		
12-2936M	Sm	62.95
12-2937M	Med	62.95
12-2938M	Lg	62.95
12-2939M	XL	62.95
12-2940M	2X	62.95
12-2941M	3X	62.95



LUMBERJACK SHERPA JACKET

Full length front zipper. Dark gray polyester Sherpa lining. 2 side pockets & 2 chest pockets with buttons. Drawstring hood.

Red		
13-23030M	XS	72.95
13-23031M	Sm	72.95
13-23032M	Med	72.95
13-23033M	Lg	72.95
13-23034M	XL	72.95
13-23035M	2X	72.95
13-23036M	3X	72.95

Blue		
13-23039M	XS	72.95
13-23040M	Sm	72.95
13-23041M	Med	72.95
13-23042M	Lg	72.95
13-23043M	XL	72.95
13-23044M	2X	72.95
13-23045M	3X	72.95

Green		
13-23063M	XS	72.95
13-23064M	Sm	72.95
13-23065M	Med	72.95
13-23066M	Lg	72.95
13-23067M	XL	72.95
13-23068M	2X	72.95
13-23069M	3X	72.95



All Tough Duck garments are premium quality and are equipped with these standard features. 12 oz 100% cotton. Machine washable. Storm Cuffs. Brass rivets. Triple stitched. Heavy-duty brass zippers. Brass dome closures. Brass fasteners. Generous fit. **Tough Duck, Tough Standards!**

Workwear



TOUGH DUCK HYDRO PARKA

Shell: 100% premium cotton duck. Lining: quilted 8 oz polyester insulation. Detachable hood with adjustable snaps. Laydown corduroy collar. Four large scoop pockets. Inside pocket and media pocket. Pencil pocket on sleeve. Rib knit storm cuffs. Brass zipper. Inside drawstring waist.

Brown		
13-7808M	Sm	122.95
13-7809M	Med	122.95
13-7810M	Lg	122.95
13-7811M	XL	122.95
13-7812M	2X	122.95
13-7813M	3X	132.95
13-7814M	4X	132.95
13-7815M	5X	132.95



TOUGH DUCK CHORE JACKET

100% cotton 12 oz premium duck with durable water repellent finish. Lining: quilted 6 oz polyester insulation. Triple stitched. Brass zipper, brass zipper closure on chest pocket. Two front welt pockets and pencil pocket on sleeve. Inside pocket, media and chest pockets. Two adjustable waist tabs. Action back. Adjustable shank button closure on cuff. Embroidery zipper.

Brown		
13-7134M	Sm	119.95
13-7135M	Med	119.95
13-7136M	Lg	119.95
13-7137M	XL	119.95
13-7138M	2X	129.50
13-7139M	3X	129.50
13-7140M	4X	143.50
13-7141M	5X	143.50



TOUGH DUCK HOODED BOMBER JACKET

100% cotton 12 oz premium duck with durable water repellent finish. Lining: quilted 6 oz polyester insulation. Triple stitches. Brass rivets at stress points, brass zipper. Three piece attached hood with draw cord. Two chest pockets and two front scoop pockets. Inside pocket and media pocket, pencil pocket on sleeve. Action back. Rib knit waist and cuffs. Embroidery zipper.

Brown		
13-7144M	Sm	124.95
13-7145M	Med	124.95
13-7146M	Lg	124.95
13-7147M	XL	124.95
13-7148M	2X	132.95
13-7149M	3X	132.95
13-7150M	4X	143.50
13-7151M	5X	143.50



TOUGH DUCK INSULATED BIB OVERALLS

100% cotton 12 oz premium duck with water repellent finish. Lining: quilted 6 oz polyester insulation. Brass rivets at stress points. Back elastic waist and adjustable shoulder straps. Waterproof seat and knees with knee pad pockets. Heavy-duty two-way brass front zipper. Ankle to hip heavy-duty two-way zippers. Loss-proof chest pocket for cell phone. Exclusive double full-chap front leg. Turned under hem allows for 3" tall extension.

Brown		
13-7116M	Sm	164.95
13-7117M	Med	164.95
13-7118M	Lg	164.95
13-7119M	XL	164.95
13-7120M	2X	164.95
13-7121M	3X	178.50
13-7122M	4X	178.50
13-7123M	5X	178.50

TOUGH DUCK DELUXE UNLINED BIB OVERALLS

100% cotton 12 oz premium duck with water repellent finish. Adjustable shoulder straps. Two-way brass front zipper. Chest, pencil pocket and pass through pocket. Loss-proof chest pocket for cell phone. Triple stitched. Exclusive full chap double front. Hammer loop and ruler pocket.



Brown		
13-7100M	Sm	94.95
13-7101M	Med	94.95
13-7102M	Lg	94.95
13-7103M	XL	94.95
13-7104M	2X	94.95
13-7105M	3X	101.50
13-7106M	4X	101.50
13-7107M	5X	101.50

CLOTHING



TOUGH DUCK ULTIMATE DUCK PARKA

100% cotton 12 oz premium duck with durable water repellent finish. Lining: quilted 8 oz polyester insulation. Triple stitched with brass rivets at stress points. Detachable hood with chin guard extension and adjustable snaps. Storm flap over two-way brass zipper. Two chest pockets and two large scoop pockets. Two large inside pockets, media pocket and pencil pocket. Action back. Rib knit storm cuffs. Inside drawstring waist. Embroidery zipper.

Dark Brown		
13-7154MSm	174.95
13-7155MMed	174.95
13-7156MLg	174.95
13-7157MXL	174.95
13-7158M2X	192.50
13-7159M3X	192.50
13-7160M4X	209.95
13-7161M5X	209.95



TOUGH DUCK CHORE JACKET

100% cotton 12 oz premium duck with durable water repellent finish. Lining: quilted 6 oz polyester insulation. Triple stitched. Brass zipper, brass zipper closure on chest pocket. Two front welt pockets and pencil pocket on sleeve. Inside pocket, media and chest pockets. Two adjustable waist tabs. Action back. Adjustable shank button closure on cuff. Embroidery zipper.

Dark Brown		
13-7164MSm	119.95
13-7165MMed	119.95
13-7166MLg	119.95
13-7167MXL	119.95
13-7168M2X	129.50
13-7169M3X	129.50
13-7170M4X	143.50
13-7171M5X	143.50



TOUGH DUCK INSULATED BIB OVERALLS

100% cotton 12 oz premium duck with water repellent finish. Lining: quilted 6 oz polyester insulation. Brass rivets at stress points. Back elastic waist and adjustable shoulder straps. Waterproof seat and knees with knee pad pockets. Heavy-duty two-way brass front zipper. Ankle to hip heavy-duty two-way zippers. Loss-proof chest pocket for cell phone. Exclusive double full-chap front leg. Turned under hem allows for 3" tall extension.

Dark Brown		
13-7124MSm	164.95
13-7125MMed	164.95
13-7126MLg	164.95
13-7127MXL	164.95
13-7128M2X	164.95
13-7129M3X	178.50
13-7130M4X	178.50
13-7131M5X	178.50



TOUGH DUCK DELUXE UNLINED BIB OVERALLS

100% cotton 12 oz premium duck with water repellent finish. Adjustable shoulder straps. Two-way brass front zipper. Chest, pencil pocket and pass through pocket. Loss-proof chest pocket for cell phone. Triple stitched. Exclusive full chap double front. Hammer loop and ruler pocket.

Dark Brown		
13-7108MSm	94.95
13-7109MMed	94.95
13-7110MLg	94.95
13-7111MXL	94.95
13-7112M2X	94.95
13-7113M3X	101.50
13-7114M4X	101.50
13-7115M5X	101.50





Clothing





BACKWOODS "ADVENTURER" JACKET & PANTS

Jacket: Waterproof & breathable fabric. Mesh lined interior for added comfort. Ideal for late summer & early fall hunting conditions. Detachable hood. 2 front pockets.

Waist Pant: Waterproof & breathable fabric. Mesh lined interior for added comfort. Ideal for late summer & early fall hunting conditions 2 cargo pockets for storage. Quiet faric for stalking.

Model: 1415 Jacket

13-10653MXS69.95
13-10654MSm69.95
13-10655MMed69.95
13-10656MLg69.95
13-10657MXL69.95
13-10658M2X69.95
13-10659M3X69.95

Model: 1425 Pants

13-10661MXS59.95
13-10662MSm59.95
13-10663MMed59.95
13-10664MLg59.95
13-10665MXL59.95
13-10666M2X59.95
13-10667M3X59.95



RANGER BASE LAYER SHIRT

Breathable & moisture wicking fabric. Crew neckline. Elasticized cuffs. Help regulate body temperature.

13-23047MXS34.95
13-23048MSm34.95
13-23049MMed34.95
13-23050MLg34.95
13-23051MXL34.95
13-23052M2X34.95
13-23053M3X34.95



UPLAND GAME VEST

The Backwoods Upland Game Vest is designed with many performance features to help deflect branches and protect your skin. The vest sports quilted shoulder pads, light mesh backing and a zippered pocket on the front which allows for easy storage while hunting.

13-10772MXS56.95
13-10773MSm56.95
13-10774MMed56.95
13-10775MLg56.95
13-10776MXL56.95
13-10777M2X56.95
13-10778M3X56.95



BACKWOODS CAMO FUR CAP

The fur lined interior keeps you warm and comfortable throughout freezing conditions while the Synthetex waterproof and breathable exterior guards your head from the elements on bitter cold nights.

13-10786P(One Size)24.95
-----------	-----------------	------------



RANGER BASE LAYER PANTS

Breathable & moisture wicking fabric. Elasticized waist & leg cuffs. Gusset crotch. Help regulate body temperature.

13-23055MXS34.95
13-23056MSm34.95
13-23057MMed34.95
13-23058MLg34.95
13-23059MXL34.95
13-23060M2X34.95
13-23061M3X34.95



BACKWOODS KIDS "ADVENTURER" JACKET & PANTS

Jacket: Soft stretchy fleece lining. Windproof, breathable & water-resistant. Mesh lined interior for added comfort. Ideal for late summer & early fall hunting conditions. Full front zipper. Elasticized cuffs. Attached hood. 2 front pockets.

Waist Pant: Soft stretchy fleece lining. Windproof, breathable & water-resistant. Mesh lined interior for added comfort. Ideal for late summer & early fall hunting conditions. 2 pockets.

Model: 1445 Jacket

13-10670MSm	64.95
13-10671MMed	64.95
13-10672MLg	64.95
13-10673MXL	64.95

Model: 1455 Pants

13-10676MSm	49.95
13-10677MMed	49.95
13-10678MLg	49.95
13-10679MXL	49.95



BACKWOODS PURE CAMO TRIGGER FINGER GLOVES

Synthetex performance fabric exterior shell. Waterproof and breathable. Fleece lined and insulated for warmth. EZ Flex trigger finger and thumb. Knuckle slit for extra flexibility.

Model: CG3

MENS

13-10834P(Med)	41.95
13-10835P(Lg)	41.95
13-10836P(XL)	41.95
13-10837P(2X)	41.95

KIDS (Model CGEK)

13-10838P(Med)	41.95
13-10839P(Lg)	41.95
13-10840P(XL)	41.95



JACKFIELD INSULATED CAMO JACKET

100% polyester brushed knit with polyurethane coating. Log & Tree pattern. Lining and pocketing 100% polyester brushed knit. Sherpa lining inside the hood and collar. Sealed seams. Removable hood with snap buttons. Plastic front zipper closure with flap and snap buttons. Two Chest pockets and two front pockets. Snap buttons adjustment on cuffs.

11-7086MXS	106.95
11-7087MSm	106.95
11-7088MMed	106.95
11-7089MLg	106.95
11-7090MXL	106.95
11-7091M2X	122.95
11-7092M3X	122.95
11-7093M4X	122.95



JACKFIELD INSULATED CAMO BIB PANT

100% polyester with polyurethane coating. 100% polyester brushed lining and pocketing. Double layer of lining on the buttocks to keep warm. Camo Log & Tree. Sealed seams. Adjustable shoulders straps. Elastic waist. Front zipper closure with snaps on front. Two rear pockets. Two cargo pockets. Side pockets. Zipper at the bottom of the legs.

11-7096MXS	79.95
11-7097MSm	79.95
11-7098MMed	79.95
11-7099MLg	79.95
11-7100MXL	79.95
11-7101M2X	91.95
11-7102M3X	91.95
11-7103M4X	91.95



BACKWOODS CAMO GLOVES

Breathable polyester. Textured palms. Exposed thumb and finger tip. Neoprene cuff. Model: CG100

13-10750PSm	26.95
13-10751PMed	26.95
13-10752PLg	26.95
13-10753PXL	26.95
13-10754P2X	26.95



BACKWOODS "PURE CAMO" PACKSACK

Synthetex waterproof and breathable fabric. 25L capacity. Adjustable padded nylon straps. Mesh flat front pocket. Model: BC250

20-003M76.95



BACKWOODS MUNGO RUCKSACK

600 denier cordura polyester. Quality rippled EVA Rubber bottom. Padded shoulder straps. **New and Improved.**

20-005M15 Litre - BP15062.95
 20-006M25 Litre - BP25079.95
 20-007M40 Litre - BP35091.95



BACKWOODS DELUXE BALACLAVA (LAVA-X)

Waterproof and breathable exterior. Fleece lined interior for extra warmth. Elasticized and adjustable front opening. Vent slits on side and front. Pure Camo® pattern

Model: LAVA-X

13-10845P(One Size)34.95



MOOSE TOQUE

Acrylic knit. Thinsulate insulation.

12-7375MBlack12.95
 12-7376MOrange12.95



DOG SAFETY VEST

Keep your best friend highly visible with the Backwoods Safety Dog Vest. Made with polyester material, the vest also features an adjustable nylon strap to custom fit your dog and an easy snap buckle. Whether it's day or night ensure maximum visibility with our lightweight Backwoods Dog Vest.

20-230PMed15.95
 20-231PLg15.95
 20-232PXL15.95



BACKWOODS PURE CAMO BALACLAVA (LAVA-C)

Ideal for hunting, snowmobiling and hiking. Fleece lined and windproof. Quiet polyester construction. Thin enough to wear under helmet. Pure Camo® pattern.

13-10846P(One Size)18.95



**Shop or Browse
 Online 24/7
 at
 mercersmarine.com**



NEOPRENE SHELL BELT

Keep up to 25 shotshells on you with the Backwoods® Neoprene Shotshell Belt. The belt fits up to 3" shells and can be adjusted up to 55".

20-121M(One Size)34.95





SPORTCHIEF PREDATOR JACKET & PANTS

Unleash the predator in you. New 3 ply shell technology. reinforced Aquatex membrane. Adjustable and removable hood. Teflon waterproofing. Deep Forest Camo. Waterproof zippers.

JACKET		
11-8714M.....	Sm	229.95
11-8715M.....	Med	229.95
11-8716M.....	Lg	229.95
11-8717M.....	XL	229.95
11-8718M.....	2X	229.95
11-8719M.....	3X	229.95
PANTS		
11-8722M.....	Sm	169.95
11-8723M.....	Med	169.95
11-8724M.....	Lg	169.95
11-8725M.....	XL	169.95
11-8726M.....	2X	169.95
11-8727M.....	3X	169.95



SPORTCHIEF DYNAMO JACKET & PANTS

Teflon treatment. Aquatex membrane. Coral fleece lining. 3 layer fabric with high density fibers. Inside layer helps regulate body heat. Jacket has detachable hood.

JACKET		
11-8598M.....	Sm	179.95
11-8599M.....	Med	179.95
11-8600M.....	Lg	179.95
11-8601M.....	XL	179.95
11-8602M.....	2X	179.95
11-8603M.....	3X	179.95
PANTS		
11-8604M.....	Sm	149.95
11-8605M.....	Med	149.95
11-8606M.....	Lg	149.95
11-8607M.....	XL	149.95
11-8608M.....	2X	149.95
11-8609M.....	3X	149.95



SPORTCHIEF HEATED VEST

Nylon outer shell. Heated front and rear. 3 modes (low / medium / high). 6 hr maximum capacity. Li/ion batteries. USB plug can charge your phone. Bluetooth technology.

11-8787M.....	Sm	184.95
11-8788M.....	Med	184.95
11-8789M.....	Lg	184.95
11-8790M.....	XL	184.95
11-8791M.....	2X	184.95
11-8792M.....	3X	184.95



SPORTCHIEF MENS RODE LINER JACKET

Soft and comfortable. Fleece lining. Three-layer microfleece soft shell. Three pockets. Soft and stretchy fabric on the shoulders, elbows and bottom for free movement. Can be added into any Sportchief jacket with zip liner.

11-8770M.....	Sm	139.95
11-8771M.....	Med	139.95
11-8772M.....	Lg	139.95
11-8773M.....	XL	139.95
11-8774M.....	2X	139.95
11-8775M.....	3X	139.95



SPORTCHIEF MENS EXPRESS 2.0 JACKET

The Express 2.0 jacket offers an improved fit, supported by pre-curved and adjustable sleeves. Completely waterproof. A lightweight coat that adapts perfectly to warmer temperatures. 3-way stretch seam sealing tape. Water resistant zippers. New lightweight hood with zipper ending at the bottom of the collar. Adjustable cuffs with tab and velcro. Mesh and nylon lining.

11-8819M.....	Sm	234.95
11-8820M.....	Med	234.95
11-8821M.....	Lg	234.95
11-8822M.....	XL	234.95
11-8823M.....	2X	234.95
11-8824M.....	3X	234.95



SPORTCHIEF MENS EXPRESS 2.0 PANTS

Completely waterproof thanks to its sealed seams and benefiting from a padded reinforcement system in the buttocks, the Express 2.0 is a lightweight pant that adapts perfectly to warmer temperatures. 3 pockets with water-repellent zippers. 18" side leg zippers, 2 cargo pockets with front zipper. Adjustable waistband with velcro. Internal webbing applied to belt loops. Front zipper.

11-8825M.....	Sm	139.95
11-8826M.....	Med	139.95
11-8827M.....	Lg	139.95
11-8828M.....	XL	139.95
11-8829M.....	2X	139.95
11-8830M.....	3X	139.95



SPORTCHIEF BEAVER HOODIE

Power Fleece fabric. 100% Polyester. Sportchief embroidery on the front. 2 pockets in the abdomen.

11-8764M.....	Sm	59.95
11-8765M.....	Med	59.95
11-8766M.....	Lg	59.95
11-8767M.....	XL	59.95
11-8768M.....	2X	59.95
11-8769M.....	3X	59.95



Ladies

SPORTCHIEF LADIES DYNAMO 2.0 JACKET & PANTS

The warm Dynamo 2.0 coat also benefits from an AquateX water-resistant membrane that pairs with a fleece interior, a perfect combination for chilly mornings when the dew gets in the way. The SilentX fabric interior absorbs noise, making the "Dynamo" surprisingly quiet. A layer of Teflon tops it all off to add water resistance.

JACKET		
11-8807M.....	XS	219.95
11-8808M.....	Sm	219.95
11-8809M.....	Med	219.95
11-8810M.....	Lg	219.95
11-8811M.....	XL	219.95
11-8812M.....	2X	219.95



Ladies

PANTS		
11-8813M.....	Sm	169.95
11-8814M.....	Med	169.95
11-8815M.....	Lg	169.95
11-8816M.....	XL	169.95
11-8817M.....	2X	169.95
11-8818M.....	3X	169.95



Ladies

SPORTCHIEF LADIES HEATED VEST

Nylon outer shell. Heated front and rear. 3 modes (low / medium / high). 6 hr maximum capacity. Li/ion batteries. USB plug can charge your phone. Bluetooth technology.

11-8794M.....	Sm	184.95
11-8795M.....	Med	184.95
11-8796M.....	Lg	184.95
11-8797M.....	XL	184.95





SPORTCHIEF YOUTH DYNAMO JACKET & PANTS

The AquateX membrane of the "Dynamo" set is paired with a layer of Teflon which makes the suit water resistant. Its fleece interior also benefits from SilentX® fabric, which absorbs noise, a perfect combination for your apprentice hunters.

JACKET

11-8776MXS129.95
11-8777MSm129.95
11-8778MMed129.95
11-8779MLg129.95
11-8780MXL129.95

PANTS

11-8781MXS84.95
11-8782MSm84.95
11-8783MMed84.95
11-8784MLg84.95
11-8785MXL84.95

SPORTCHIEF YOUTH REBEL SUIT

100 gr. Thermo-Bond insulation. Adjustable hood. 2 lower pockets. Inside front facing zippers for zip in liner jacket.

11-8561MSm229.95
11-8562MMed229.95
11-8563MLg229.95
11-8564MXL229.95



SPORTCHIEF MENS DYNAMO GLOVES

Coral fleece fabric.

11-8536MMed49.95
11-8537MLg49.95
11-8538MXL49.95

SPORTCHIEF MENS LXS GLOVES

A lightweight water resistant glove that can be worn alone in early fall or as an under glove in cold weather.

11-8530MMed44.95
11-8531MLg44.95
11-8532MXL44.95



SPORTCHIEF SUSPENDERS

11-8534MBlack/Orange34.95
----------	-------------------	------------



SPORTCHIEF CAMO HAT

A classic cap whose panels are made of waterproof fabric making it water resistant.

11-8657MRipper24.95
11-8658MDeep Forest24.95



SPORTCHIEF HEATED GLOVES

Thermobonded insulation. 3 modes (low / medium / high). Maximum capacity of 8 hours. Lithium ion battery.

11-8799MSm/Med164.95
11-8800MLg/XL164.95



SPORTCHIEF LADIES HEATED MITTS

Thermobonded insulation. 3 modes (low / medium / high). Maximum capacity of 8 hours. Lithium ion battery.

11-8803MXS164.95
11-8804MSm/Med164.95
11-8805MLg/XL164.95



SKIPPER HATS

Heavy weight cotton canvas. Fold up brim with snap sides. Foam padded crown. Metal mesh ventilation holes. Adjustable chin cord.

12-052PMed (Natural)22.95
12-053PLg (Natural)22.95
12-054PXL (Natural)22.95
12-055PMed (Tan)22.95
12-056PLg (Tan)22.95
12-057PXL (Tan)22.95



BOSUN HAT

Heavy weight cotton canvas. Fold down brim with snap sides. Foam padded crown. Metal mesh covered ventilation holes. Unique rear tie system adjusts tension on headband. Adjustable chin cord.

12-042PSm25.95
12-043PMed25.95
12-044PLg25.95
12-045PXL25.95
12-046P2X25.95



KOALA SUNHAT

Heavyweight cotton canvas. Brushed nylon fabric with UV coating. Fold Down brim with snap sides. Foam padded crown. Wire in brim helps to maintain shape. Mesh top ring for ventilation. Unique rear tie system adjusts tension on headband. Adjustable chin cord.

12-1007PMed (Natural)27.50
12-1008PLg (Natural)27.50
12-1009PXL (Natural)27.50
12-1010PMed (Tan)27.50
12-1011PLg (Tan)27.50
12-1012PXL (Tan)27.50



CAMOUFLAGE BOSUN HAT

Heavy weight cotton canvas. Fold down brim with snap sides. Bug free ventilation eyelets. Foam padded crown. Zippered inner compartment. Adjustable chin cord.

12-1013PMed25.50
12-1014PLg25.50
12-1015PXL25.50

NEW



MESH BUG CAP

Baseball cap style with rear fabric cover. Mesh fits over peak- enlarges face room for extra comfortable fit. Long mesh front can fit under shirt/layers to seal out bugs. Mesh back fits under collar. Adjustable tension rear pull cord with stopper.

12-896P14.95
---------	-------	------------



BUG JACKETS

Rugged 100% Polyester mesh. Perfect for fishing, hunting, camping, gardening, and other outdoor activities

Adults (Unisex)

12-1308PSm18.95
12-1309PMed18.95
12-1310PLg18.95
12-1311PXL18.95
12-1312P2X18.95

Childs (Boys or Girls)

12-1306POne Size18.95
----------	---------------	------------

Youth (Boys or Girls)

12-1307POne Size18.95
----------	---------------	------------



COMPACT MOSQUITO HEAD NET

This mosquito head net is made of soft polyester netting and fits into a stuff sack or pocket for easy transportation. Made of 220 holes per sq. inch mesh is easy to see through and keeps mosquitoes and other insects out.

20-326M5.50
---------	-------	-----------



HEAD/NECK NET

Fine mesh frameless head net. Fits over ball cap or floppy hat. Full cut to protect front and back of neck. Elastic corded underarm ties.

12-1315P8.95
----------	-------	-----------



R.C.M.P. STYLE (FUR TOP)

Full Muskrat fur top with outside fur ear flaps. Made in Canada.

12-698M.....	Sm	249.95
12-699M.....	Med	249.95
12-700M.....	Lg	249.95
12-701M.....	XL	249.95
12-702M.....	2X	249.95

R.C.M.P. STYLE (MELTON TOP)

Muskrat fur hat available with dark color melton cloth top. Outside fur ear flaps. Made in Canada.

12-703M.....	Sm	164.95
12-704M.....	Med	164.95
12-705M.....	Lg	164.95
12-706M.....	XL	164.95
12-707M.....	2X	164.95

R.C.M.P. STYLE (LEATHER TOP)

Muskrat fur hat with genuine leather top. One of our most popular hats. Outside fur ear flaps. Made in Canada.

12-712M.....	Sm	199.95
12-713M.....	Med	199.95
12-714M.....	Lg	199.95
12-715M.....	XL	199.95
12-716M.....	2X	199.95



RABBIT AVIATOR HAT

Lambskin cover. Black.

12-985M.....	Med	139.95
12-986M.....	Lg	139.95
12-987M.....	XL	139.95



RACCOON BOMBER HAT

Leather top. Tie down ear flaps. Made in Canada.

12-993M.....	Sm	239.95
12-994M.....	Med	239.95
12-995M.....	Lg	239.95
12-996M.....	XL	239.95

www.mercersmarine.com



- Always Open
- Sale & Feature items
- View Catalogue



- Thousands of products
- Updated Regularly
- Up to date Pricing



- Mobile Friendly
- Shop from anywhere at anytime

Also find us on   



SYNTHETIC FUR HAT

Synthetic fur hat with fake leather top. Heatlocker insulation system. Fold down ear flaps with tie.

12-6008R.....	Sm	44.95
12-6009R.....	Med	44.95
12-6010R.....	Lg.....	44.95
12-6011R.....	XL.....	44.95

RABBIT FUR HAT (GOATSKIN LEATHER)

Rabbit hat with soft goatskin leather top. Soft fleece insulated lining. Fold down ear flaps with tie.

12-5402P.....	Sm	114.95
12-5403P.....	Med	114.95
12-5404P.....	Lg.....	114.95
12-5405P.....	XL.....	114.95

AVIATORS SKI HAT

Nylon outer with warm rabbit fur inner. Fold down earflaps close quickly with quick release buckle. Provides warmth for both ears & back of neck.

Black		
12-1251P.....	Sm	74.95
12-1252P.....	Med	74.95
12-1253P.....	Lg.....	74.95
12-1254P.....	XL.....	74.95



NEW



GOATSKIN/RABBIT HAT

Goatskin leather hat, with rabbit fur trims, quilted nylon lining and cords at the chin.

12-275P.....	Sm	119.95
12-276P.....	Med	119.95
12-277P.....	Lg.....	119.95
12-278P.....	XL.....	119.95
12-279P.....	2X.....	119.95



TOUGH DUCK CANVAS AVIATOR HAT

Fabric: 100% cotton duck. Lining: 100% cotton quilted with 40g 3M™ Thinsulate™ Insulation. Pile trim: 100% polyester. Snapped up visor. Pile trimmed ear flap with button. Hearing holes under ear flaps. Adjustable chin strap.

13-7850M.....	Lg.....	28.95
13-7851M.....	XL.....	28.95

SYNTHETIC FUR/NYLON REFLECTIVE SAFETY HAT

Orange		
12-063P.....	Sm	36.95
12-064P.....	Med	36.95
12-065P.....	Lg.....	36.95
12-066P.....	XL.....	36.95
12-067P.....	2X.....	36.95

Black		
12-068P.....	Sm	36.95
12-069P.....	Med	36.95
12-070P.....	Lg.....	36.95
12-071P.....	XL.....	36.95
12-072P.....	2X.....	36.95



MERCER'S

Phone : 709 466 7430
 www.mercersmarine.com
 Email : info@mercersmarine.com

Find us on  & 



LASKA TUQUE

Cuff tuque made of acrylic knit with a twisted and ribbed pattern and lined with polar fleece.

12-286P	Black	29.95
12-287P	Navy	29.95
12-288P	Grey	29.95

LASKA MITTS

Women's polyester mitt, with a glove liner, an adjustable strap at the wrist and an elastic knitted cuff.

12-261P	Sm	36.95
12-262P	Med	36.95
12-263P	Lg	36.95
12-264P	XL	36.95

LASKA TUQUE WITH FUR

Cuff tuque made of acrylic knit with a ribbed pattern, adorned with a raccoon fur pompom and lined with polar fleece.

12-280P	Black	46.95
12-281P	White	46.95
12-282P	Charcoal	46.95
12-283P	Purple	46.95



LASKA TUQUE

Cuff tuque made of acrylic knit with a ribbed pattern.

12-289P	Black	36.95
12-290P	Grey	36.95

LASKA MITTS

Women's polyester mitt, with an inner Heatlocker membrane and an adjustable strap at the wrist.

12-271P	Sm	49.95
12-272P	Med	49.95
12-273P	Lg	49.95
12-274P	XL	49.95

LASKA TUQUE WITH POMPOM

Light knitted hat with a ribbed pattern, made of a mix of viscose, nylon and polyester and adorned with a genuine fur pompom.

12-291P	Black	39.95
12-292P	White	39.95
12-293P	Navy	39.95



CANADA GOOSE®

The Thermal Experience Index

Canada Goose developed the Thermal Experience Index (TEI) to help you find the warmth you want for the experience you seek in each of our products. Whether you need a lightweight jacket for active pursuits or a field-tested parka for the coldest places on earth, this five-point system is designed to help you make the right selection from our expansive collections. Please note: our Thermal Experience Index is measured in Celsius.



TEI¹
LIGHTWEIGHT
 -2°C to -5°C
 Lightweight for active pursuits.



TEI²
VERSATILE
 -5°C to -10°C
 Ultimate in core warmth, comfort and versatility.



TEI³
FUNDAMENTAL
 -10°C to -20°C
 Fundamental warmth fashioned for everyday use.



TEI⁴
ENDURING
 -20°C to -30°C
 Inspired by the Arctic and made for enduring daily warmth.



TEI⁵
EXTREME
 -30°C and below
 Field-tested for the coldest places on earth.



SNOW MANTRA PARKA

Designed to conquer anything the elements can throw at it, the hard-working Snow Mantra Parka, insulated with top quality 675-fill power white goose down features 3M™ reflective tape for easy visibility, handy D-ring glove attachment point, and shoulder straps for lifting and rescue, should an emergency occur. No one working in extreme conditions should be without this kind of protection. **For more detailed specs on the Snow Mantra Parka, visit our website at www.mercersmarine.com.**

Mens Red - Model 9501M

13-500A2XS1895.00
13-501AXS1895.00
13-502ASm1895.00
13-503AMed1895.00
13-504ALg1895.00
13-505AXL1895.00
13-506A2X1895.00
13-507A3X1895.00



ARCTIC RIGGER COVERALL

The number one industrial coverall combines extreme warmth and durability. This is a product that will last in the field for years.

Features: Poly-cotton Arctic Tech outer shell is treated with a Durable Water Repellent; two-way heavy-duty YKK® side zippers; 625 fill power duck down filled; recessed, heavy-duty, rib-knit cuffs and internal waist band; two large lower pockets with flaps and two fleece-lined hand warmer pockets; tunnel hood with adjustable bracing wire and removable fur ruff.

Mens Black - Model 2310M

13-600AXS1125.00
13-601ASM1125.00
13-602AMED1125.00
13-603ALG1125.00
13-604AXL1125.00
13-605A2XL1125.00



TUNDRA CARGO PANT

Adjustable waistband with exterior buckles. Silicon gripper elastic on interior waistband. Snap, hook and eye centre front closure. Reinforced inseam hem panels. Heavy-duty reinforced knee and seat panel. Elasticized internal snow gaitors with snap closure. Reflective tape on lower side zipper placket. Front cargo pockets secured with snaps; additional brushed tricot exterior pocket with zipper closure. Centre front YKK locking zipper. Heavy-duty, side leg, 2-way, YKK locking zipper for easy on and off. Removable, adjustable elastic suspenders. Inseam length: 32" / 81.28cm

Mens Tundra Cargo Pants - Model 4811M

11-1412AXS	11-1416AXL
11-1413ASm	11-1417A2X
11-1414AMed	11-1418A3X
11-1415ALg		

Ladies Tundra Cargo Pants - Model 4811L

11-1426AXS	11-1429ALg
11-1427ASm	11-1430AXL
11-1428AMed	11-1431A2X

All Tundra Cargo Pants \$625.00





EXPEDITION PARKA

Originally developed for scientists working in research facilities at McMurdo station in Antarctica, the Expedition Parka™ is one of our most iconic, warmest and durable parkas. It features a highly functional collection of external pockets, perfect for easy gear storage and hand warming. Draw cord waist. Coyote fur ruff surrounding a two-way adjustable tunnel hood with an adjustable bracing wire reduces wind penetration by allowing you to adjust size as conditions dictate. Four fleece-lined upper and lower pockets with zipper closure. Mid-thigh length for maximum coverage and protection. Two lower full-below snow pockets secured with Velcro® flaps. Two upper chest pockets secured with Velcro® flaps. Storm flap over front zipper. Heavy-duty, recessed, flexible rib-knit cuffs. An elasticized nylon snowskirt. Centre back length: 35" (Mens) 33" (Ladies).

Mens Black - Model 4660M

11-11151A.....Sm	11-11154AXL
11-11152A.....Med	11-11155A2X
11-11153ALg	11-11156A3X

Mens Red - Model 4660M

11-11144A.....Sm	11-11147AXL
11-11145A.....Med	11-11148A2X
11-11146ALg	11-11149A3X

Ladies Black - Model 4660L

11-11229AXS	11-11232ALg
11-11230A.....Sm	11-11233AXL
11-11231A.....Med	

All Expedition Parkas \$1395.00



RESOLUTE DOWN PARKA

The Resolute is an iconic parka of Canada Goose, and one on which their name has been built. Nothing can match the quality and workmanship that goes into each and every parka manufactured. Poly-cotton Arctic Tech outer shell is treated with a Durable Water Repellent finish. 625 fill power white duck down filled. Two-way heavy-duty YKK® zipper. Recessed, heavy-duty, rib-knit cuffs to keep out the cold. Double-reinforced elbows for durability. 3M™ reflective tape across the back and on front chest pockets. Tunnel hood with adjustable bracing wire and detachable coyote fur ruff. Packed with a multitude of pockets and two Grabber® hand warmers.

Mens Red - Model 8501M

13-631A.....XS	13-635A.....XL
13-632A.....Sm	13-636A.....2X
13-633A.....Med	13-637A.....3X
13-634A.....Lg	13-638A.....4X

Mens Black - Model 8501M

13-772A.....XS	13-776A.....XL
13-773A.....Sm	13-777A.....2X
13-774A.....Med	13-778A.....3X
13-775A.....Lg	13-779A.....4X

Ladies Red - Model 8501L

13-659A.....XS	13-662A.....Lg
13-660A.....Sm	13-663A.....XL
13-661A.....Med	

Ladies Black - Model 8501L

13-788A.....XS	13-791A.....Lg
13-789A.....Sm	13-792A.....XL
13-790A.....Med	

All Resolute Parkas \$1495.00

Prices are subject to change. Check our website for up to date prices. www.mercersmarine.com





-15/-25 C



-10/-20 C



CONSTABLE PARKA

Developed in co-operation with Northern Police and Special Forces members, the Constable Parka services a uniquely demanding combination of needs complicated by a challenging environment. It provides extreme weather protection as well as easy access to zippers in the event of emergencies. Recessed, heavy-duty, flexible, nylon rib-knit cuffs keep out the cold. Centre back length: 31.5" (80cm). Removable hood designed with a drip flap and snap-secured collar allowing the option of obtaining maximum coverage around the neck and chin. Two lower front pockets secure with Velcro® flaps. Two lower side slash pockets. Hip-length for increased mobility while still maintaining ample protection from the elements. Waist draw cord provides an additional element of warmth when tightened. Option to hang your parka using the strap on the back. (Ladies Model , Inquire).

Mens Black - Model 4071M

- 13-708AXS
- 13-709ASm
- 13-710AMed
- 13-711ALg

Mens Navy - Model 4071M

- 11-1593AXS
- 11-1594ASm
- 11-1595AMed
- 11-1596ALg

- 11-1597AXL
- 11-1598A2X
- 11-1599A3X

All Constable Parkas \$895.00

MENS MACMILLAN PARKA

Stylized hem with rounded side slits and extended back panel for better coverage and protection. 3-way adjustable tunnel hood (hood opening, horizontally and vertically). Brushed tricot chin guard for comfort. Heavy-duty centre front YKK® 2-way locking zipper. Storm flap over centre front zipper secured with snap buttons. Two exterior fleece-lined handwarmer pockets. Interior security pocket with zipper closure. Heavy-duty rib-knit cuffs keep out the cold. Centre back length : 30.5"

Mens Black - Model 3804M-61

- 11-10777ASm
- 11-10778AMed
- 11-10779ALg
- 11-10780AXL
- 11-10781A2X
- 11-10782A3X

Mens Navy - Model 3804M-67

- 11-11236ASm
- 11-11237AMed
- 11-11238ALg
- 11-11239AXL
- 11-11240A2X
- 11-11241A3X

All Macmillan Parkas \$1075.00



-15/-25 C



CARSON PARKA

Mid-thigh length. 3-way adjustable tunnel hood (hood opening and vertically). Brushed tricot lined chin guard for comfort. Heavy-duty, centre front YKK 2-way locking zipper. Storm flap over centre front zipper secured with snap closure. Two lower fleece lined welt handwarmer pockets with zipper closure. Napoleon pocket with zipper closure. Interior zippered security pocket. Recessed, heavy-duty, rib-knit cuffs keep out the cold. Centre back length 33.5".

Mens Black - Model 3805M

- 11-10329AXS
- 11-10330ASm
- 11-10331AMed
- 11-10332ALg

Mens Graphite - Model 3805M

- 11-10810ASm
- 11-10811AMed
- 11-10812ALg
- 11-10813AXL
- 11-10814A2X
- 11-10815A3X

All Carson Parkas \$1695.00





Canada Goose

MENS CROFTON HOODY BLACK LABEL

This is the hooded jacket you'll reach for all Spring long: As a warm layer under your rain jacket on colder, rainier mornings; with a wind shell on blustery afternoons; by itself on those summer evenings with a hint of a chill. The Crofton Hoody is a versatile, lightweight all-rounder that even packs into itself for easy portability.

Mens Black - Model 2227MB-61

- 11-1133ASm
- 11-1134AMed
- 11-1135ALg

Mens Atlantic Navy - Model 2227MB-63

- 11-1139ASm
- 11-1140AMed
- 11-1141ALg
- 11-1142AXL
- 11-1143A2X

All Crofton Hoody Black Label \$895.00

MENS HYBRIDGE LITE TECH HOODY

HyBridge Lite delivers lightweight, breathable warmth designed to move with you. New enhancements have been made this season, including a narrower quilting pattern at flex points to enhance fit. Perfect for active use, layering, or travel packability, HyBridge Lite is as versatile as you need it to be.

Mens Black - Model 2712M-61

- 11-11248ASm
- 11-11249AMed
- 11-11250ALg
- 11-11251AXL
- 11-11252A2X

Mens Atlantic Navy - Model 2712M-63

- 11-11253AXS
- 11-11254ASm
- 11-11255AMed
- 11-11256ALg
- 11-11257AXL
- 11-11258A2X

All Hybrid Lite Tech Hoody \$795.00



MENS CROFTON JACKET BLACK LABEL

This is the jacket you'll reach for all Spring long: As a warm layer under your rain jacket on colder, rainier mornings; with a wind shell on blustery afternoons; by itself on those summer evenings with a hint of a chill. The Crofton Jacket is a versatile, lightweight all-rounder that even packs into itself for easy portability.

Mens Black - Model 2228MB-61

- 11-1121ASm
- 11-1122AMed
- 11-1123ALg

Mens Atlantic Navy - Model 2228MB-63

- 11-1127ASm
- 11-1128AMed
- 11-1129ALg
- 11-1130AXL
- 11-1131A2X
- 11-1132A3X

All Crofton Jacket Black Label \$850.00



MENS FREESTYLE CREW VEST

This exceptional, down-filled vest is the ultimate layering piece that can be worn across all seasons. A classic, and versatile vest that is a well-insulated layer.

Mens Black - Model 4154M-61

- 11-10797AXS
- 11-10798ASm
- 11-10799AMed
- 11-10800ALg
- 11-10801AXL
- 11-10802A2X
- 11-10803A3X

All Freestyle Crew Vest \$595.00



MENS LODGE HOODY

This season, we've taken our best-selling Lodge Hoody and introduced it in a new matte finish. Warm and windproof but compressing to almost nothing, the Lodge Hoody is ideal for backcountry activities and lightweight packing. The full feature hood, drop down tail and extra nylon ripstop shell provide further protections, helping to keep valuable body heat in.

Mens Black - Model 5078M-61

- 11-11196AXS
- 11-11197ASm
- 11-11198AMed
- 11-11199ALg

Mens Atlantic Navy - Model 5078M-63

- 11-11259AXS
- 11-11260ASm
- 11-11261AMed
- 11-11262ALg

All Lodge Hoody \$695.00

MENS NANAIMO RAIN JACKET

This handsome shell jacket from Canada Goose is a style that you'll reach for time and time again to ensure protection against unpredictable weather. Its water-repellent shell will help keep you dry while its semi-slim fit allows extra room for layering over heavier knits. Try pairing the practical piece with one of the brand's down-filled vests for extra warmth.

Mens Black - Model 5608M-61

- 11-1161ASm
- 11-1162AMed
- 11-1163ALg
- 11-1164AXL
- 11-1165A2X

Mens Atlantic Navy - Model 5608M-63

- 11-1156ASm
- 11-1157AMed
- 11-1158ALg
- 11-1159AXL
- 11-1160A2X

All Nanaimo Rain Jacket \$595.00



MENS LODGE JACKET

This season, we've taken our best-selling Lodge Jacket and introduced it in a new matte finish. Warm and windproof, the Lodge Jacket is perfect for mild winter days or cooler spring and fall evenings. And due to its ability to be packed neatly into its own inner pocket, it is ideal for backcountry activities.

Mens Black - Model 5079M-61

- 11-11203AXS
- 11-11204ASm
- 11-11205AMed
- 11-11206ALg

Mens Atlantic Navy - Model 5079M-63

- 11-11210AXS
- 11-11211ASm
- 11-11212AMed
- 11-11213ALg
- 11-11214AXL
- 11-11215A2X
- 11-11216A3X

All Lodge Jacket \$650.00





-10/-20 C



Black



Navy

LADIES SHELburne PARKA - MODEL 3802L

Long-thigh length. Removable coyote fur ruff surrounding a 2-way adjustable hood (hood opening, vertically). Brushed tricot chin guard for comfort. Heavy-duty, centre front YKK 2-way locking zipper. Storm flap over centre front zipper secured with snap button closure. Two front fleece-lined hand pockets with interior snap closure. Adjustable snap cuff. Recessed heavy-duty rib-knit cuffs to keep out the cold. Two lower back-vents secured with snap closure. Two interior pockets; right inside security pocket with zipper closure. Left pocket drop-in with headphone access opening. Interior shoulder straps allow wearer to carry over their shoulder. Centre back length: 35.5" / 90.17cm.

Black - Model 3802L-61

- 11-9362AXS
- 11-9363ASm
- 11-9364AMed

Navy - Model 3802L-63

- 11-9365ALg
- 11-9366AXL
- 11-9367A2X

- 11-9383AXS
- 11-9384ASm
- 11-9385AMed

- 11-9386ALg
- 11-9387AXL
- 11-9388A2X

All Ladies Shelburne Parkas \$1250.00



-10/-20 C



Black

LADIES ROSSCLAIR PARKA

Interior elastic drawcord to adjust the waist. Mid-thigh length cut longer in the back with zippered gusset for more movement and protection from cold and wind. Vertically adjustable, adjustable hood opening, adjustable bracing wire for superior protection in high wind conditions, non-removable. Removable coyote fur ruff. Suede tricot-lined collar and chin guard for comfort. Heavy-duty centre front YKK® 2-way locking zipper. Interior shoulder straps allow wearer to carry over their shoulder. Two exterior fleece-lined handwarmer pockets with interior snap closure. Two interior pockets: Upper security zippered pocket and lower mesh stuff pocket. Heavy-duty rib-knit cuffs keep out the cold. Centre back length : 36.5".

Black - Model 2580L

- 11-10698AXS
- 11-10699ASm
- 11-10700AMed
- 11-10701ALg
- 11-10702AXL
- 11-10703A2X

All Ladies Rossclair Parkas \$1250.00



-10/-20 C



Black



Navy

LADIES VICTORIA PARKA

Mid-thigh length. Removable coyote fur ruff, with an adjustable bracing wire for superior protection in high-wind conditions, on a removable hood with a Velcro secured collar adds warmth and versatility. Heavy-duty, centre front YKK 2-way locking zipper. Storm flap over centre front zipper secured with Velcro. Two lower front fleece-lined welt handwarmer pockets secured with zipper closure. Two interior pockets; right security pocket with zipper closure, left drop-in with stretch media pocket with headphone access opening. Adjustable waist drawcord provides added warmth. Interior shoulder straps allow wearer to carry over their shoulder. Recessed, heavy-duty, flexible, rib-knit cuffs. Back vent with hidden snap closure. Centre back length: 33" / 83.82cm.

Black - Model 3037L-61

- 13-569AXS
- 13-570ASm
- 13-571AMed

Navy - Model 3037L-67

- 13-572ALg
- 13-573AXL
- 13-574A2X

- 11-9217AXS
- 11-9218ASm
- 11-9219AMed

- 11-9220ALg
- 11-9221AXL
- 11-9222A2X

All Ladies Victoria Parkas \$1250.00

TEI³
-10/-20 C



LADIES CHELSEA PARKA

Water Resistant. Removable, vertically adjustable, adjustable hood opening, & adjustable bracing wire for superior protection in high wind conditions. Removable coyote fur ruff. Heavy-duty centre front YKK® 2-way locking zipper. Interior shoulder straps allow wearer to carry over their shoulder. Two exterior fleece-lined handwarmer pockets. Interior security pocket with zipper closure. Heavy-duty rib-knit cuffs keep out the cold. Centre back length : 28".

Black - Model 3804L

- 11-10733AXS 11-10736ALg
- 11-10734ASm 11-10737AXL
- 11-10735AMed 11-10738A2X

All Chelsea Parkas \$1395.00

TEI¹
5°C/-5°C



LADIES CYPRESS HOODED JACKET

An everyday essential, this effortless hooded jacket will transition seamlessly from city sidewalks to mountain trails. A piece as sophisticated as it is functional, the Cypress Jacket has versatile details like an adjustable waist and longer length for added warmth and elemental protection.

Ladies Black - Model 2235L-61

- 11-11302AXS 11-11305ALg
- 11-11303ASm 11-11306AXL
- 11-11304AMed

Ladies Black Label - Model 2235LB-61

- 11-1100AXS 11-1104AXL
- 11-1101ASm 11-1105A2X
- 11-1102AMed 11-1106A3X
- 11-1103ALg

All Cypress Hooded Jacket \$950.00

TEI¹
5°C/-5°C



LADIES CYPRESS JACKET BLACK LABEL

An everyday essential, this effortless jacket will transition seamlessly from city sidewalks to mountain trails. A piece as sophisticated as it is functional and is designed to do double-time as a warmth-boosting layer under a shell in cooler temperatures. The Cypress Jacket will be that go-to piece you can't believe you lived without.

Ladies Black - Model 2236L-61

- 11-1107AXS 11-1111AXL
- 11-1108ASm 11-1112A2X
- 11-1109AMed 11-1113A3X
- 11-1110ALg

Ladies Atlantic Navy - Model 2236LB-63

- 11-1114AXS 11-1118AXL
- 11-1115ASm 11-1119A2X
- 11-1116AMed 11-1120A3X
- 11-1117ALg

All Cypress Jacket Black Label \$850.00





LADIES ELLISON JACKET

This lightweight, slim-fit jacket is designed with our Feather-Light fabric for essential warmth and protection from the elements. A removable down-filled hood and fishtail hem add coverage and warmth. Pack the whole jacket into an interior pocket for easy travel.

Ladies Black - Model 2209L-61

- 11-11162AXS
- 11-11163ASm
- 11-11164AMed
- 11-11165ALg
- 11-11166AXL
- 11-11167A2X

Ladies Atlantic Navy - Model 2209L-63

- 11-11296AXS
- 11-11297ASm
- 11-11298AMed
- 11-11299ALg
- 11-11300AXL
- 11-11301A2X

All Ellison Jacket \$795.00

LADIES LUNDELL JACKET BLACK LABEL

Designed for transitional seasons, the Lundell Jacket is made with AcclimaLuxe, a multi-functional fabric with a premium hand feel that protects you from the outdoor elements. The Lundell has a drawcord at the waist for adjustable cinching, a two-way zipper and an adjustable hood for customizable protection.

Ladies North Star White Black Label
Model 2438WB-433

- 11-1196AXS
- 11-1197ASm
- 11-1198AMed
- 11-1199ALg
- 11-1200AXL
- 11-1201A2X

Ladies Black Black Label - Model 2438WB-61

- 11-1202AXS
- 11-1203ASm
- 11-1204AMed
- 11-1205ALg
- 11-1206AXL
- 11-1207A2X

All Lundell Jacket \$595.00



LADIES CYPRESS HOODY

Made with an ultra-lightweight fabric with ripstop construction, the Cypress Hoody is designed to withstand high winds, light rain and snow. It has an adjustable hood, signature double-stripe reflective on the back of the hood and is packable into an interior pocket for easy travel. Our signature disc completes this style.

Ladies Sagebrush - Model 2242W-852

- 11-1144AXS
- 11-1145ASm
- 11-1146AMed
- 11-1147ALg
- 11-1148AXL
- 11-1149A2X

Ladies Black Label - Model 2242WB-200

- 11-1150AXS
- 11-1151ASm
- 11-1152AMed
- 11-1153ALg
- 11-1154AXL
- 11-1155A2X

All Cypress Hooded Hoody \$895.00





Atlantic Navy



North Star White



Black



Black
Black Label



North Star White
Black Label

LADIES KENORA JACKET

Designed for elevated performance in a lightweight package. This essential jacket provides easy transitioning for whatever nature brings your way. Fully seam-sealed and stowable for travel and effortless movement. Fully seam-sealed construction and exposed Aquaguard water-resistant zippers keep rain out. Jacket is lightweight enough to roll up and easily stow into hood. Once stowed away, cinch drawcord to pack down even further for easy travel. Hood has single adjustment point at back that cinches two ways at once. Extended brim construction with a head skirt underneath allows the hood to move with you and stay out of your line of sight. Signature double-stripe reflective details at brim and back add low light visibility. Mesh venting underneath the back panel adds breathability and air flow while keeping rain out. Edge is reflective for added visibility in low light. Articulated sleeves and underarm gussets enhance fit and add range of motion. Scalloped cuffs provide extra coverage and adjust with hook-and-loop closures to seal out rain. Edges are reflective for added visibility in low light. Stormguard with reflective detailing underneath 2-way zipper keeps the elements out. Unzip from the bottom for added range of motion or venting.

Ladies Atlantic Navy - Model 5618L-63

11-1166AXS	11-1169ALg
11-1167ASm	11-1170AXL
11-1168AMed	11-1171A2X

Ladies Nort Star White - Model 5618L-433

11-1172AXS	11-1175ALg
11-1173ASm	11-1176AXL
11-1174AMed	11-1177A2X

Ladies Black - Model 5618L-61

11-1178AXS	11-1181ALg
11-1179ASm	11-1182AXL
11-1180AMed	11-1183A2X

Ladies Black Black Label - Model 5618LB-61

11-1184AXS	11-1187ALg
11-1185ASm	11-1188AXL
11-1186AMed	11-1189A2X

Ladies North Star White Black Label - Model 5618LB-433

11-1190AXS	11-1193ALg
11-1191ASm	11-1194AXL
11-1192AMed	11-1195A2X

All Kenora Jacket \$650.00





Canada Goose

LADIES HYBRIDGE LITE TECH HOODY

HyBridge Lite delivers lightweight, breathable warmth designed to move with you. New enhancements have been made this season, including a narrower quilting pattern at flex points to enhance fit. Perfect for active use, layering, or travel packability, HyBridge Lite is as versatile as you need it to be.

Ladies Black - Model 2712L-61

- 11-11242AXS
- 11-11243ASm
- 11-11244AMed

- 11-11245ALg
- 11-11246AXL
- 11-11247A2X

Ladies Atlantic Navy - Model 2712L-63

- 11-11266AXS
- 11-11267ASm
- 11-11268AMed

- 11-11269ALg
- 11-11270AXL
- 11-11271A2X

All Hybridge Lite Tech Hoody \$795.00



LADIES HYBRIDGE LITE HOODED COAT

HyBridge Lite delivers lightweight, breathable warmth designed to move with you. New enhancements have been made this season, including a narrower quilting pattern at flex points to enhance fit. Perfect for active use, layering, or travel packability, HyBridge Lite is as versatile as you need it to be.

Ladies Black - Model 2716L-61

- 11-11284AXS
- 11-11285ASm
- 11-11286AMed

- 11-11287ALg
- 11-11288AXL
- 11-11289A2X

Ladies Atlantic Navy - Model 2716L-63

- 11-11290AXS
- 11-11291ASm
- 11-11292AMed

- 11-11293ALg
- 11-11294AXL
- 11-11295A2X

All Hybridge Lite Hooded Coat \$775.00



LADIES HYBRIDGE LITE TECH JACKET

HyBridge® Lite delivers lightweight, breathable warmth designed to move with you. New enhancements have been made this season, including a narrower quilting pattern at flex points to enhance fit. Perfect for active use, layering, or travel packability, HyBridge® Lite is as versatile as you need it to be.

Ladies Black - Model 2714L-61

- 11-11272AXS
- 11-11273ASm
- 11-11274AMed

- 11-11275ALg
- 11-11276AXL
- 11-11277A2X

Ladies Atlantic Navy - Model 2714L-63

- 11-11278AXS
- 11-11279ASm
- 11-11280AMed

- 11-11281ALg
- 11-11282AXL
- 11-11283A2X

All Hybridge Lite Tech Jacket \$750.00



LADIES FREESTYLE VEST

Our transitional weather favourite gets an update with feminine quilting, a longer back hem and soft touchpoints. Featuring reflective details at the back of the collar, this exceptional down-filled vest is a versatile layering piece with endless possibilities.

Ladies Black - Model 2836L-61

11-11329A2XS	11-11333ALg
11-11330AXS	11-11334AXL
11-11331ASm	11-11335A2X
11-11332AMed	

All Freestyle Vest \$595.00



LADIES TUNDRA PANTS

No matter your environment or activity, wild winds and frigid temperatures can slice through pants to freeze the skin on your legs in moments. In these extreme cold weather conditions, the insulated Tundra Down Pants are the ideal partner to your Canada Goose parka.

Ladies Black - Model 4810L-61

11-10399A2XS	11-10403ALg
11-10400AXS	11-10404AXL
11-10401ASm	11-10405A2X
11-10402AMed	

All Tundra Pants \$595.00



LADIES WEEKEND CAP

Designed with a low-profile silhouette and adjustable self-strap. The Weekend Cap features our embroidered wordmark logo.

Model 5483W

11-1209A.....White	150.00
11-1208A.....Black.....	150.00
11-1210A.....Lilac.....	150.00



ARCTIC DOWN GLOVES & MITTS

Cord lock with elastic draw cord at cuff opening. Low profile Velcro Closure for wrist cinch. Glove clips. Hardface fleece cuffs. Canada Goose Arctic Disc.

MENS - Black Gloves Model 5159M

11-10442ASm	11-10444ALg
11-10443AMed	11-10445AXL

MENS - Black Mitts Model 5158M

11-10438ASm	11-10440ALg
11-10439AMed	11-10441AXL

All Mens Arctic Down Gloves & Mitts \$195.00



LADIES - Black Gloves Model 5159L

11-10454AXS	11-10456AMed
11-10455ASm	11-10457ALg

LADIES - Black Mitts Model 5158L

11-10450AXS	11-10452AMed
11-10451ASm	11-10453ALg

All Ladies Arctic Down Gloves & Mitts \$195.00



UNISEX TONAL CAP

Designed with a low-profile silhouette and unlined, stretch panels for comfort. The Tonal Cap features our signature disc in a tonal finish.

Model 5481U

11-1211A.....Sm/Med.....	150.00
11-1212A.....Med/Lg.....	150.00
11-1213A.....Lg/XL.....	150.00





2023-24 FXR

COLD INSULATED RATING ICONS



1 UNINSULATED

MILD WEATHER / AGGRESSIVE RIDING GEAR

A value of 1 has no thermal insulation and is suitable for mild climates or situations where intensive perspiration occurs.

10 INSULATED

COLD WEATHER / LOW ACTIVITY RIDING GEAR

Values between 7-10 have extremely high thermal properties and are able to withstand extreme temperatures, well below -40°C/F and will keep you warm during sedentary outdoor activities.

10 INSULATED COMBO

SHELL & FIXED LINING COMBINED INSULATION RATING

If the item is a 2-in-1 or 3-in-1 (indicating it has a removable liner), both the "SHELL" and "COMBO" (combined) value of the shell and liner will be displayed.



Black/Blue/HiVis

FXR



Insulated with F.A.S.T. Combo

F.A.S.T.
FLUOROPOLYESTER ASSOCIATED
SHELL™ TECHNOLOGY



Black Ops



'22 Black Ops

CX F.A.S.T. Insulated Monosuit - \$899.00 (2X - 3X \$919.00)

HydrX Pro™ – 10,000mm/8,000g/m². Shell - durable, sublimated 450d polyester shell with HydrX Pro™ laminate. Seam-sealed in critical areas. Lining - mesh/fleece lining system. FAST Insulated- 180g combined F.A.S.T.™. Thermal Flex™ insulation value. F.A.S.T.™ is perforated in seat panel for improved breathability. FXR Dry Vent™ system - snowproof and moisture resistant side body, chest & leg vent system. Hd #8 waterproof 2-way front zipper. Hd #8 waterproof zippers throughout. 360° 3M™ Scotchlite™ reflective. Shock-cord adjustable collar. Removable/adjustable hood. Adjustable cuffs with lycra inner cuff extensions. Padded knees. Thermal seat/dry seat & knee inserts. Adjustable suspender system. Reinforced instep & drop-down adjustable hem. Storm cuffs with hook & loop/snap closure and front/ rear boot lace retention snaps. Back leg hem length adjusters.

Black/Blue/HiVis

- 13-92530KSm
- 13-92531KMed
- 13-92532KLg

- 13-92533KXL
- 13-92534K2X
- 13-92535K3X

Black Ops

- 13-92516KSm
- 13-92517KMed
- 13-92518KLg
- 13-92519KXL
- 13-92520K2X
- 13-92521K3X

'22 Black Ops

- 13-92524KMed
- 13-92525KLg
- 13-92526KXL
- 13-92527K2X
- 13-92528K3X



Black

FXR



Insulated with F.A.S.T. Combo

F.A.S.T.
FLUOROPOLYESTER ASSOCIATED
SHELL™ TECHNOLOGY



Black/Charcoal

Excursion Monosuit - \$659.00

(2X - 4X \$679.00)

HydrX™ 5,000mm / 5,000g / m². Shell - Durable 600d Polyester Shell with HydrX Laminate. Seam-sealed in critical areas. Lining - Nylon Taffeta Quilted Lining. F.A.S.T. 3.0 255g combined F.A.S.T. / Thermal Flex insulation value. F.A.S.T. is perforated at seat and vents for improved breathability. FXR Dry Vent system - snowproof and moisture resistant side body system. Heavy duty YKK Vislon 2-way front zipper. YKK zippers throughout. Large cargo pockets at chest and thigh area. 2-way YKK waist height leg zippers with outer placket. Removable / adjustable hood. Thermal seat, dry seat, and dry knee inserts. Cold stop front placket with hook and loop / snap closure system. Adjustable cuffs with lycra inner cuff extensions. Elasticized back. Adjustable suspenders. Pre-curved / padded knees. Storm cuffs with hook and loop / snap closure and boot lace retention system. Drop down adjustable hem. 360° 3M Scotchlite Reflective.

Black

- 13-92631KSm
- 13-92632KMed
- 13-92633KLg
- 13-92634KXL
- 13-92635K2X
- 13-92636K3X
- 13-92637K4X

Black/Charcoal

- 13-92638KSm
- 13-92639KMed
- 13-92640KLg
- 13-92641KXL
- 13-92642K2X
- 13-92643K3X



Black/HiVis



Black Ops



Insulated with F.A.S.T. Combo



Black/Blue



Black/Red

Recruit F.A.S.T Insulated Monosuit - \$759.00 (2X - 3X \$779.00)

HydrX Pro™ – 10,000mm/8,000g/m². Shell - durable, sublimated 300d polyester shell with HydrX Pro™ laminate. Seam-sealed in critical areas. F.A.S.T. Insulated-180g combined F.A.S.T./Thermal Flex™ insulation value. F.A.S.T.™ is perforated in seat panel for improved breathability. Lining - fleece/mesh lining system. FXR Dry Vent™ system - snowproof and moisture resistant chest and side body system. Hd #8 waterproof 2-way front zipper. Hd #8 waterproof zippers throughout. 360° 3M™ Scotchlite™ reflective. Collar with fixed adjustable hood. Adjustable cuffs. Padded knees. Thermal seat/dry seat & knee inserts. Reinforced instep & hem. Storm cuffs with hook & loop/snap closure and front/rear boot lace retention snaps. Back leg hem length adjusters.

Black/HiVis

13-91700K.....Sm	13-91703K.....XL
13-91701K.....Med	13-91704K.....2X
13-91702K.....Lg	

Black Ops

13-91706K.....Sm	13-91709K.....XL
13-91707K.....Med	13-91710K.....2X
13-91708K.....Lg	13-91711K.....3X

Black/Blue

13-91719K.....Sm	13-91722K.....XL
13-91720K.....Med	13-91723K.....2X
13-91721K.....Lg	

Black/Red

13-91713K.....Sm	13-91716K.....XL
13-91714K.....Med	13-91717K.....2X
13-91715K.....Lg	

Prices are subject to change. Check our website for up to date prices. www.mercersmarine.com



4

Shell Only
W/F.A.S.T.

10

Insulated
Combo



F.A.S.T.
HEAT PROTECTION



10

Insulated
with
F.A.S.T
Combo



8

F.A.S.T
Insulated



Adrenaline Jacket & Pant

Jacket is Insulated Shell With Removable Liner. Feed your appetite for the rush of a winter ride with the all-out performance and technically superior design of our Adrenaline jacket and pant. Clean, sophisticated styling meets premium materials, components and technology including Omni-Stretch™, ACMT™, Dry Vent™, and most importantly, F.A.S.T.™ technology, the Adrenaline ensures that your last mile will be as warm and comfortable as the first. See more details at mercersmarine.com

Black Ops

13-92470K.....Med	13-92473K.....2X
13-92471K.....Lg	13-92474K.....3X
13-92472K.....XL	

Adrenaline Jacket \$669.00 (2X - 3X \$689.00)

Black Ops

13-91803K.....Med	13-91806K.....2X
13-91804K.....Lg	13-91807K.....3X
13-91805K.....XL	

Adrenaline Pant \$539.00 (2X - 3X \$559.00)

Excursion Ice Pro Jacket - \$459.00

(2X - 3X \$479.00)

HydrX Pro™ 10,000mm / 8,000g / m². Shell – 450d polyester shell with HydrX Pro™ laminate. Lining - mesh / fleece lining. F.A.S.T. 3.0™ – 220g combined F.A.S.T.™ / FXR Thermal Flex™ insulation value. F.A.S.T.™ is perforated at vents for improved breathability. FXR Dry Vent™ system - snowproof and moisture resistant chest and side body vent system. Durable YKK® zippers throughout. Heavy duty YKK® #8 Vislon® 2-way front zipper. Dual entry cargo pockets. Cold stop front placket with hook and loop / snap closure. Adjustable cuffs with water-resistant inner cuff extensions. Adjustable windskirt. Collar with adjustable fixed hood. Shock-cord adjustable hem. 360° Reflective inserts.

Black

13-92433K.....Sm	13-92436K.....XL
13-92434K.....Med	13-92437K.....2X
13-92435K.....Lg	13-92438K.....3X



8

Insulated
with
F.A.S.T
Combo



Excursion Pant - \$429.00 (2X - 3X \$449.00)

HydrX Pro™ 10,000mm / 8,000g / m². Shell – 600d polyester shell with HydrX Pro™ laminate. Seam-sealed in critical areas. Lining - moisture wicking quick dry mesh lining. F.A.S.T. 3.0™ – 210g combined F.A.S.T.™ / FXR Thermal Flex™ insulation value. F.A.S.T.™ is perforated at seat panel for improved breathability. Durable YKK® zippers throughout. Heavy duty #8 waterproof chest pocket zipper. Waist height YKK® 2-way leg zippers with placket. Adjustable fixed suspenders. Adjustable waist system. Waist / hip flex stretch insert. Thermal seat, dry seat, and dry knee inserts. Padded knees with removable knee pads. Reinforced knee, instep and drop down adjustable hem. Storm cuffs with hook & loop / snap closure and front / rear boot lace retention system. Back leg length adjuster. Reflective inserts.

Black

13-92439K.....Sm	13-92442K.....XL
13-92440K.....Med	13-92443K.....2X
13-92441K.....Lg	13-92444K.....3X



FXR

FXR



Insulated Shell with F.A.S.T



Insulated Combo

F.A.S.T
FLOATATION ASSISTANCE SAFETY TECHNOLOGY



Black/Charcoal/Gold



Black



Black Ops



Black/Red



Black/Blue

TEAM FX JACKET - \$549.00 (2X to 4X -\$569.00)

HydrX Pro™ 10,000mm / 8,000g / m². Shell - durable nylon shell with HydrX Pro™ laminate. Zonal Omni-Stretch™ inserts at upper back and back sleeves. F.A.S.T. 4.0™ - 150g F.A.S.T.™ insulation value in outer shell body. F.A.S.T.™ is perforated at vents for improved breathability. Lining - moisture wicking quick dry mesh lining. FXR Dry Vent™ system - snowproof and moisture resistant chest and side body vent system. Removable liner - FXR Thermal Dry™ active liner with 120g Thermal Flex™ fill. Heavy duty YKK® Vislon® front zipper. Heavy duty #8 waterproof chest zippers. YKK® zippers throughout. Adjustable windskirt. Adjustable collar and hem. Cold stop front placket with magnetic / snap closure system. Adjustable cuffs with lycra inner cuff extensions. 360° reflective inserts.

Color	Size	Small	Medium	Large	XL	2X	3X	4X
Black/Charcoal/Gold		13-92590K	13-92591K	13-92592K	13-92593K	13-92594K	13-92595K	-
Black		13-92650K	13-92651K	13-92652K	13-92653K	13-92654K	13-92655K	13-92656K
Black Ops		13-92666K	13-92667K	13-92668K	13-92669K	13-925670	13-92671K	13-92672K
Black/Red		13-92680K	13-92681K	13-92682K	13-92683K	13-92684K	13-92585K	-
Black/Blue		13-92674K	13-92675K	13-92676K	13-92677K	13-92678K	13-92679K	-



F.A.S.T. insulation is made from an expanded, low-density polyethylene foam membrane that offers buoyancy assistance for up to two hours. FXR jacket and pants with F.A.S.T. must be worn together as a suit to achieve buoyancy properties.

FXR CLOTHING



Black



Insulated with F.A.S.T. Combo



Black Ops



Black/Red

Team FX Pant - \$459.00 (2X to 4X - \$479.00)

HydrX Pro™ 10,000mm / 8,000g / m². Shell - durable nylon shell with HydrX Pro™ laminate. Seam-sealed in critical areas. Lining - moisture wicking quick dry mesh lining. F.A.S.T. 4.0™ – 240g combined F.A.S.T.™ / FXR Thermal Flex™ insulation value. F.A.S.T.™ is perforated at seat panel for improved breathability. YKK® zippers throughout. Durable YKK® 2-way front zipper with placket and snap closure. High height YKK® 2-way leg zippers with placket and snap closure. Waist / hip flex stretch insert. Thermal seat, dry seat, and dry knee inserts. Padded knees. Adjustable / removable suspenders. Reinforced knee, instep and drop down adjustable hem. Storm cuffs with snap closure and front boot lace retention snaps. Back leg length adjuster. Reflective inserts.

Color	Size	Small	Medium	Large	XL	2X	3X	4X
Black		13-92733K	13-92734K	13-92735K	13-92736K	13-92737K	13-92738K	13-92739K
Black Ops		13-92748K	13-92749K	13-92750K	13-92751K	13-92752K	13-92753K	-
Black/Red		13-92742K	13-92743K	13-92744K	13-92745K	13-92746K	-	-



Insulated with F.A.S.T. Combo



Clutch FX Pant - \$399.00 (2X - 3X - \$419.00)

HydrX Pro™ 10,000mm / 8,000g / m². Shell - durable, sublimated 450d polyester shell with HydrXPro™ laminate. Seam-sealed in critical areas. Lining - moisture wicking quick dry mesh lining. F.A.S.T. 3.0™ – 180g combined F.A.S.T.™ / FXR Thermal Flex™ insulation value. F.A.S.T.™ is perforated at seat and vents for improved breathability. FXR Dry Vent™ system - snowproof and moisture resistant thigh vent system. YKK® zippers throughout. Lower leg zippers with outer placket. Thermal seat, dry seat, and dry knee inserts. Adjustable / removable suspenders. Adjustable waist system. Pre-curved and padded knees. Reinforced instep and drop down adjustable hem. Storm cuffs with snap closure and front boot lace retention snaps. 3M™ Scotchlite™ reflective.

Black/White

13-3786KSm	13-3789KXL
13-3787KMed	13-3790K2X
13-3788KLg	13-3791K3X

Black Ops

13-3792KSm	13-3795KXL
13-3793KMed	13-3796K2X
13-3794KLg	13-3797K3X

FXR



Blue/HiVis



Insulated with F.A.S.T Combo

F.A.S.T.
FLUOROPOLYMER ASSISTANCE
SAFETY TECHNOLOGY



Black Ops



Black

FXR



Black/Red



Black/Grey

Octane Jacket - \$429.00 (2X to 5X -\$449.00)

HydrX™— 5,000mm / 5,000g / m². Shell - durable nylon shell with HydrX™ laminate. Lining – mesh / fleece lining. F.A.S.T. 3.0™ – 250g combined F.A.S.T.™ / FXR Thermal Flex™ insulation value. F.A.S.T.™ is perforated at vents for improved breathability. FXR Dry Vent™ system - snowproof and moisture resistant chest, side body vent system. YKK® zippers throughout. Heavy duty YKK® #8 Vislon® front zipper. Adjustable windskirt. Adjustable collar and hem. Cold stop front placket with magnetic / snap closure system. Adjustable cuffs with lycra inner cuff extensions. 360° 3M™ Scotchlite™ reflective.

Color	Size	Small	Medium	Large	XL	2X	3X	4X	5X
Blue/HiVis		13-92694K	13-92695K	13-92696K	13-92697K	13-92698K	13-92699K	-	-
Black Ops		13-92700K	13-92701K	13-92702K	13-92703K	13-92704K	13-92705K	-	-
Black		13-92706K	13-92707K	13-92708K	13-92709K	13-92710K	13-92711K	13-92712K	13-92713K
Black/Red		13-92715K	13-92716K	13-92717K	13-92718K	13-92719K	13-92720K	-	-
Black/Grey		13-92721K	13-92722K	13-92723K	13-92724K	13-92725K	13-92726K	-	-

F.A.S.T.
FLUOROPOLYMER ASSISTANCE
SAFETY TECHNOLOGY

F.A.S.T. insulation is made from an expanded, low-density polyethylene foam membrane that offers buoyancy assistance for up to two hours. FXR jacket and pants with F.A.S.T. must be worn together as a suit to achieve buoyancy properties.

MEN	2XS	XS	S	M	L-SH	L	L-T	XL-SH	XL	XL-T	2XL-SH	2XL	3XL-SH	3XL	4XL	5XL	6XL
Chest Circumference	34-35	36-37	38-39	40-41	42-43	44-45	46-47	48-49	50-51	52-53	54-55	56-57	58-59	60-61	62-63	64-65	66-67
Waist Circumference	27-28	29-30	31-32	33-34	35-36	37-38	39-40	41-42	43-44	45-46	47-48	49-50	51-52	53-54	55-56	57-58	59-60
Hip Circumference	30-31	32-33	34-35	36-37	38-39	40-41	42-43	44-45	46-47	48-49	50-51	52-53	54-55	56-57	58-59	60-61	62-63
Arm Length From Center Back Neck	31 1/2	32 3/8	33 1/4	34 1/8	34	35	36 1/2	37 3/8	38 1/4	39 1/8	40 1/4	41 1/4	42 1/4	43 1/4	44 1/4	45 1/4	46 1/4
Inseam	28	30	31	32	33 1/2	34	35	36 1/2	37 1/2	38 1/2	39 1/2	40 1/2	41 1/2	42 1/2	43 1/2	44 1/2	45 1/2

Prices are subject to change. Check our website for up to date prices. www.mercersmarine.com

FXR CLOTHING



389

FXR



Black/Charcoal/Grey



F.A.S.T.
Insulated



Insulated
Combo



Black/Blue/HiVis

Boost FX Jacket (2 in 1 Jacket) - \$459.00 (2X - 3X - \$479.00)

Jacket is Insulated Shell With Removable Liner. HydrX Pro™ - 10,000mm/8,000g/m². Shell - durable, sublimated 450d polyester shell with HydrX Pro™ laminate. F.A.S.T. 3.0™ 90g insulation value in outer shell body, perforated at vent areas. Lining - moisture-wicking quick-dry mesh lining. FXR Dry Vent™ system - snowproof and moisture resistant chest & side body vent system. Removable liner - FXR Thermal Dry™ active liner with 175g Thermal Flex™ fill. YKK® Aquaguard front zipper. HD #8 W/P zippers throughout. Adjustable windskirt. 360° 3M™ Scotchlite™ reflective. Shock-cord adjustable collar. Shock-cord adjustable bottom hem. Removable/adjustable hood. Adjustable cuffs with lycra inner cuff extensions.

Black/Charcoal/Grey

13-92383KSm	13-92386KXL
13-92384KMed	13-92387K2X
13-92385KLg	13-92388K3X

Black/Blue/HiVis

13-92390KSm	13-92393KXL
13-92391KMed	13-92394K2X
13-92392KLg	13-92395K3X

FXR



Insulated
with
F.A.S.T.
Combo



Black/Charcoal/
White Fade

F.A.S.T.
FLEXIBLE ACTIVE SHIELD™
3.0™



Black Ops

CX Jacket - \$459.00 (2X - 3X \$479.00)

HydrX Pro™ 10,000mm / 8,000g / m². Shell - durable, sublimated 450d polyester shell with HydrX Pro™ laminate. Lining - mesh / fleece lining system. F.A.S.T. 3.0™ - 260g combined F.A.S.T.™ / FXR Thermal Flex™ insulation value. F.A.S.T.™ is perforated at vents for improved breathability. FXR Dry Vent™ system - snowproof and moisture resistant chest and side body vent system. Heavy duty YKK® #8 Vislon® front zipper. YKK® zippers throughout. Adjustable windskirt. Cold stop front placket with hook and loop / snap closure system. Shock-cord adjustable collar and hem. Removable / adjustable hood. Adjustable cuffs with lycra inner cuff extensions. 360° 3M™ Scotchlite™ reflective.

Black/Charcoal/White Fade

13-3672KSm	13-3675KXL
13-3673KMed	13-3676K2X
13-3674KLg	13-3677K3X

Black Ops

13-3666KSm	13-3669KXL
13-3667KMed	13-3670K2X
13-3668KLg	13-3671K3X



FXR**F.A.S.T.**
SAFETY PERFORMANCE**FXR****7**Warmth
Rating**8**Warmth
Rating**FXR****Fuel Jacket - \$399.00 (2X - 3X - \$419.00)**

HydrX™ 5,000mm / 5,000g / m². Shell - durable, sublimated 450d polyester shell with HydrX™ laminate. Lining - moisture wicking quick dry mesh lining. F.A.S.T. 3.0™ - 250g combined F.A.S.T.™ / FXR Thermal Flex™ insulation value. F.A.S.T.™ is perforated at vents for improved breathability. FXR Dry Vent™ system - snowproof and moisture resistant side body vent system. Heavy duty YKK® #8 Vislon® front zipper. YKK® zippers throughout. Adjustable windsirt. Cold stop front placket with magnetic / snap closure system. Shock-cord adjustable collar and hem. Removable / adjustable hood. Adjustable cuffs with lycra inner cuff extensions. 3M™ Scotchlite™ reflective.

Black Ops

13-17100K.....Sm	13-17103K.....XL
13-17101K.....Med	13-17104K.....2X
13-17102K.....Lg	13-17105K.....3X

Fuel Pant - \$339.00 (2X - 5X - \$359.00)

HydrX™ - 5,000mm / 5,000g / m². Shell - durable nylon / polyester shell with HydrX™ laminate. Seam-sealed in critical areas. Lining - moisture wicking quick dry mesh lining. Insulation - 225g Thermal Flex™ insulation. YKK® zippers throughout. Waist height 2-way leg zippers with outer placket. Adjustable fixed suspenders. Thermal seat, dry seat, and dry knee inserts. Padded knees. Adjustable hem. Reinforced instep and hem. Storm cuffs with boot lace retention snaps. 3M™ Scotchlite™ reflective.

Black

13-3804K.....Sm	13-3812K.....2X
13-3805K.....Med	13-3814K.....3X
13-3807K.....Lg	13-3816K.....4X
13-3810K.....XL	13-3817K.....5X

FXR**CLOTHING**Prices are subject to change. Check our website for up to date prices. www.mercersmarine.com**391**



6

F.A.S.T Insulated

F.A.S.T
FLUOROPOLYMER ASSISTED
SAFETY TECHNOLOGY

Black/Raspberry/
HiVis Fade



Black/Charcoal/
Fuchsia



Black/Mint/
Electric Pink



Black/Sky/Lilac/White Fade



Ladies Recruit F.A.S.T. Insulated Monosuit - \$699.00

HydrX Pro™ 10,000mm / 8,000g / m². Shell - durable, sublimated 300d polyester shell with HydrX Pro™ laminate. Seam-sealed in critical areas. Lining - fleece / mesh lining system. F.A.S.T. 3.0™ 180g combined F.A.S.T.™ / Thermal Flex™ insulation value. F.A.S.T.™ is perforated at seat and vents for improved breathability. FXR Dry Vent™ system - snowproof and moisture resistant chest & side body system. Heavy duty #8 waterproof zippers throughout. 2-way waterproof front zipper. Knee height waterproof leg zippers. Collar with fixed adjustable hood. Adjustable cuffs. Padded knees. Thermal seat, dry seat, and dry knee inserts. Adjustable suspenders. Reinforced instep and hem. Storm cuffs with hook and loop / snap closure and front / rear boot lace retention snaps. Back leg length adjusters. Reflective inserts.

Black/Raspberry/HiVis Fade

13-3450K4	13-3454K12
13-3451K6	13-3455K14
13-3452K8	13-3456K16
13-3453K10	

Black/Charcoal/Fuchsia

13-3460K4	13-3464K12
13-3461K6	13-3465K14
13-3462K8	13-3466K16
13-3463K10	

Black/Mint/Electric Pink

13-3470K4	13-3474K12
13-3471K6	13-3475K14
13-3472K8	13-3476K16
13-3473K10	

Black/Sky/Lilac/White Fade

13-3490K4	13-3494K12
13-3491K6	13-3495K14
13-3492K8	13-3496K16
13-3493K10	



9

F.A.S.T Insulated



**Ladies Excursion Monosuit - \$649.00
(Sizes 18 to 20 - \$669.00)**

HydrX™ 5,000mm / 5,000g / m². Shell - Durable 300d Polyester Shell with HydrX™ Laminate. Seam-sealed in critical areas. Lining - Nylon taffeta quilted lining. F.A.S.T. 3.0™ -255g combined F.A.S.T.™ / Thermal Flex™ insulation value. F.A.S.T.™ is perforated at seat and vents for improved breathability. FXR Dry Vent™ system - snowproof and moisture resistant side body system. YKK® zippers throughout. 2-way YKK® waist height leg zippers with outer placket. Heavy duty YKK® #8 Vislon® 2-way front zipper. Large cargo pockets at chest and thigh area. Removable / adjustable hood. Thermal seat, dry seat, and dry knee inserts. Cold stop front placket with hook and loop / snap closure system. Adjustable cuffs with lycra inner cuff extensions. Elasticized back. Adjustable suspenders. Pre-curved / padded knees. Storm cuffs with hook and loop / snap closure and front / rear boot lace retention system. Drop down adjustable hem. 360° 3M™ Scotchlite™ Reflective.

Black/Fuchsia

13-3630K4	13-3634K12
13-3631K6	13-3635K14
13-3632K8	13-3636K16
13-3633K10	13-3637K18

Black/Charcoal/Mint

13-3567K4	13-3571K12
13-3568K6	13-3572K14
13-3569K8	13-3573K16
13-3570K10	



6
F.A.S.T
Insulated

F.A.S.T
FLEXIBLE ADJUSTABLE SEAM TECHNOLOGY™



Black/Muted Grape



Black/Neon Fusion



Black/
Dusty Rose

Ladies CX F.A.S.T. Insulated Monosuit - \$799.00

HydrX Pro™ 10,000mm / 8,000g / m². Shell - durable, sublimated 300d polyester shell with HydrX Pro™ laminate. Seam-sealed in critical areas. Lining - mesh / fleece lining system. F.A.S.T. 3.0™ 180g combined F.A.S.T.™ / Thermal Flex™ insulation value. F.A.S.T.™ is perforated at seat and vents for improved breathability. FXR Dry Vent™ system - snowproof and moisture resistant side body, chest & leg vent system. Heavy duty #8 waterproof zippers throughout. 2-way waterproof front zipper. Drop seat system with 2-way waterproof zipper. Knee height waterproof leg zippers. Shock-cord adjustable collar. Removable / adjustable hood. Adjustable cuffs with lycra inner cuff extensions. Padded knees. Thermal seat, dry seat, and dry knee inserts. Adjustable suspenders. Reinforced instep and drop down adjustable hem. Storm cuffs with hook and loop / snap closure and front / rear boot lace retention system. Back leg length adjusters. 360° 3M™ Scotchlite™ Reflective and reflective inserts.

Black/Muted Grape

13-3597K4	13-3601K12
13-3598K6	13-3602K14
13-3599K8	13-3603K16
13-3600K10	

Black/Neon Fusion

13-3604K4	13-3608K12
13-3605K6	13-3609K14
13-3606K8	13-3610K16
13-3607K10	

Black/Dusty Rose

13-3611K4	13-3615K12
13-3612K6	13-3616K14
13-3613K8	13-3617K16
13-3614K10	



WOMEN	2/2XS	4/XS	A/S	8/M	16/L	12-SH	12/XL	14-SH	14/2XL	16/3XL	18/4XL	20/5XL	22/6XL	24/7XL
Chest Circumference	31-32	33-34	35-36	37-38	39-40	41-42	41-42	43-44	43-44	45-46	47-48	49-50	52-53	55-56
Waist Circumference	27-28	29-30	31-32	33-34	35-36	37-38	37-38	39-40	39-40	41-42	43-44	45-46	46-49	51-52
Hip Circumference	37-38	34-35	36-37	38-39	40-41 1/2	42 1/2-44	42 1/2-44	45-46 1/2	45-46 1/2	47 1/2-49	50-51 1/2	52 1/2-54	55 1/2-57	58 1/2-60
Arm Length From Center Back Neck	29 1/2	30 1/4	31	31 3/4	32 1/2	31 1/2	32 7/8	31 1/2	33 1/8	33 1/2	33 7/8	34 1/4	34 1/4	34 1/4
Inseam	29	30	30	30	30 1/2	28 1/2	30 1/2	28	30	29 1/2	29	29	29	29



FXR

9

F.A.S.T
Insulated
Combo

F.A.S.T
INSULATED COMBO



Ladies Excursion Jacket - \$419.00

HydrX Pro™ 10,000mm / 8,000g / m². Shell - durable 300d polyester shell with HydrX Pro™ laminate. Lining - mesh / fleece lining. F.A.S.T. 3.0™ - 250g - combined F.A.S.T.™ / FXR Thermal Flex™ insulation value. Heavy Duty YKK® #8 Vislon® 2-way front zipper. Durable YKK® zippers throughout. Cold stop front placket with hook and loop / snap closure system. Dual entry hand cargo pockets. Removable / adjustable hood. Shock-cord adjustable collar and bottom hem. Adjustable windskirt. Adjustable cuffs with lycra inner cuff extensions. Reflective inserts.

Black Linen/ Electric Pink	
13-4280K4	13-4284K12
13-4281K6	13-4285K14
13-4282K8	13-4286K16
13-4283K10	

FXR

8

F.A.S.T
Insulated
Combo

F.A.S.T
INSULATED COMBO



Ladies Excursion Pants - \$399.00

HydrX Pro™ 10,000mm / 8,000g / m². Shell - durable 450d polyester shell with HydrX Pro™ laminate. Seam-sealed in critical areas. Lining - moisture wicking quick dry mesh lining. F.A.S.T. 3.0™ - 210g - combined F.A.S.T.™ / FXR Thermal Flex™ insulation value. F.A.S.T.™ is perforated at seat panel for improved breathability. Durable YKK® zippers throughout. Heavy duty #8 waterproof chest pocket zipper. Full length 2-way YKK® leg zippers with placket. Adjustable suspenders with drop seat function at back. Adjustable waist system. Waist / hip flex stretch inserts. Thermal seat, dry seat, and dry knee inserts. Pre-curved and padded knees with removable knee pads. Reinforced knee, instep and drop-down adjustable hem. Storm cuffs with snap closure and front boot lace retention snaps. Back leg length adjusters. Reflective inserts.

Black	
13-4290K4	13-4294K12
13-4291K6	13-4295K14
13-4292K8	13-4296K16
13-4293K10	

FXR

4

Shell Only
W/F.A.S.T.

10

Insulated
Combo



Ladies Adrenaline Jacket - \$579.00 (Sizes 18-20 \$599.00)

A.C.M.T.™ - 20,000mm / 8,000g / m². Shell - durable Omni-Stretch™ nylon / spandex shell with HydrX Pro™ laminate. F.A.S.T. 3.0™ - 90g F.A.S.T.™ insulation value in outer shell body. F.A.S.T.™ is perforated at vents for improved breathability. Lining - moisture wicking quick-dry mesh lining. Z-liner - fully seam-sealed hidden z-lining with A.C.M.T.™ HydrX Pro™ laminate & integrated venting. FXR Dry Vent™ system - snowproof and moisture resistant chest and side body vent system. Removable liner - FXR Thermal Dry™ active liner with 175g Thermal Flex™ fill and Exkin® inserts for added warmth. Heavy duty YKK® #8 Vislon® front zipper. Heavy duty #8 waterproof chest pocket and side vent zippers. YKK® zippers at hand pockets. Cold stop front placket with magnetic / snap closure system. Adjustable collar and bottom hem. Adjustable windskirt. Adjustable cuffs with lycra inner cuff extensions. 360° 3M™ Scotchlite™ reflective.

Black/Fuchsia	
13-4301K6	13-4305K14
13-4302K8	13-4306K16
13-4303K10	13-4307K18
13-4304K12	13-4308K20

LADIES ADRENALINE PANT - \$479.00 (Sizes 18-20 \$499.00)

A.C.M.T. - 20,000mm / 8,000g / m². Shell - durable Omni-Stretch nylon shell with HydrX Pro laminate. Seam-sealed in critical areas. Lining - A.C.M.T. Seam-sealed lining system with HydrX Pro laminate. F.A.S.T. 3.0 - 210g combined F.A.S.T. / FXR Thermal Flex insulation value. F.A.S.T. is perforated at seat panel for improved breathability. Exkin inserts at inner back bib for added warmth. YKK zippers throughout. Full length YKK 2-way leg zippers with outer plackets. Adjustable / removable suspenders with drop seat function at back. Adjustable waist system. Waist / hip flex stretch insert. Thermal seat, dry seat, and dry knee inserts. Pre-curved knees. Reinforced instep and drop down adjustable hem. Storm cuffs with hook & loop / snap closure and front / rear boot lace retention snaps. Back leg length adjusters. Reflective inserts and screen prints.

Black/Fuchsia	
13-4320K4	13-4325K14
13-4321K6	13-4326K16
13-4322K8	13-4327K18
13-4323K10	13-4328K20
13-4324K12	



FXR

9

Insulated

F.A.S.T
INSULATED COMBO



FXR

F.A.S.T.
FLEX AIR SYSTEM™



4

F.A.S.T.
Insulated
Shell

9

Insulated
Combo



FXR

Ladies Team FX Jacket - \$439.00 (Sizes 18-20 \$459.00)

Jacket is Insulated Shell With Removable Liner. HydrX Pro 10,000mm / 8,000g / m². Shell - M-Series Omni-Stretch 300d polyester shell with HydrX Pro laminate. F.A.S.T. 3.0 - 250g coombined F.A.S.T. / FXR Thermal Flex insulation value. F.A.S.T. is perforated at vents for improved breathability. Lining - Nylon taffeta lining with Sherpa fleece center back panel. FXR Dry Vent system - snowproof and moisture resistant side body vent system. YKK Vislon front zipper. YKK zippers throughout. Adjustable windskirt. Cold stop front placket with magnetic / snap closure system. Adjustable collar and hem. Adjustable cuffs with lycra inner cuff extensions. 360° reflective inserts.

Black/Fuchsia

13-92880K6	13-92884K14
13-92881K8	13-92885K16
13-92882K10	13-92886K18
13-92883K12	13-92887K20

Black/White

13-92890K6	13-92894K14
13-92891K8	13-92895K16
13-92892K10	13-92896K18
13-92893K12	13-92897K20



Black/White

FXR

8

Insulated with
F.A.S.T. Combo



Black Ops

F.A.S.T.
FLEX AIR SYSTEM™



Black/Fuchsia

Ladies Team FX Pants - \$419.00 (Sizes 18-20 \$439.00)

HydrX Pro™ 10,000mm / 8,000g / m². Shell - M-Series Omni-Stretch™ 300d polyester shell with HydrX Pro™ laminate. Seam-sealed in critical areas. Lining - Nylon taffeta lining. F.A.S.T. 3.0™ - 210g F.A.S.T.™ / FXR Thermal Flex™ insulation value. F.A.S.T.™ is perforated at seat panel for improved breathability. Durable YKK® zippers throughout. Full length YKK® 2-way leg zippers with outer plackets. Adjustable suspenders with drop seat function at back. Adjustable waist system. Waist / hip flex stretch insert. Thermal seat, dry seat, and dry knee inserts. Pre-curved knees. Reinforced instep and drop down adjustable hem. Storm cuffs with snap closure and front boot lace retention snaps. Back leg length adjusters. Reflective inserts and screen prints.

Black/White

13-92959K4	13-92964K14
13-92960K6	13-92965K16
13-92961K8	13-92966K18
13-92962K10	13-92967K20
13-92963K12	

Black Ops

13-4400K4	13-4405K14
13-4401K6	13-4406K16
13-4402K8	13-4407K18
13-4403K10	13-4408K20
13-4404K12	

Black/Fuchsia

13-92979K4	13-92984K14
13-92980K6	13-92985K16
13-92981K8	13-92986K18
13-92982K10	13-92987K20
13-92983K12	

Prices are subject to change. Check our website for up to date prices. www.mercersmarine.com

FXR CLOTHING

FXR



Black/Seafoam/
Mint fade

2

Insulated
Shell

8

Insulated
Combo



Black/Silver



Black/Mid Grey Heather/
Raspberry fade

Ladies Edge Jacket - \$499.00 (Size 18 \$519.00)

Jacket is Insulated Shell With Removable Liner. A.C.M.T.[™] - 20,000mm / 8,000g / m². Shell - M-Series Omni-Stretch[™] 300d polyester shell with HydrX Pro[™] laminate. Lining - A.C.M.T.[™] seam-sealed lining system with HydrX Pro[™] laminate & integrated venting. FXR Dry Vent[™] system - snowproof and moisture resistant chest pocket and side body vent system. Removable liner - FXR Thermal Dry[™] active liner with 200g Thermal Flex[™] fill. Durable YKK[®] front zipper and hand pockets. Heavy duty #8 waterproof chest zippers and side body vents. Adjustable windskirt with pant attachment system. Cold stop front placket with hook and loop / snap closure system. Shock-cord adjustable collar and hem. Removable / adjustable hood. Adjustable cuffs with lycra inner cuff extensions. Reflective screen prints.

Black/Seafoam/Mint fade

13-90590K4	13-90594K12
13-90591K6	13-90595K14
13-90592K8	13-90596K16
13-90593K10	

Black/Silver

13-90600K4	13-90604K12
13-90601K6	13-90605K14
13-90602K8	13-90606K16
13-90603K10	

Black/Mid Grey Heather/Raspberry fade

13-90625K4	13-90630K14
13-90626K6	13-90631K16
13-90627K8	13-90632K18
13-90628K10	13-90633K20
13-90629K12	

FXR

F.A.S.T.
FAST ADVANCED
SHELL TECHNOLOGY

Black/Sky Blue/
White



8

F.A.S.T.
Insulated
Combo

Black/
Raspberry Fade



Ladies EVO FX Jacket - \$489.00 (Sizes 18-20 \$509.00)

HydrX Pro[™] 10,000mm / 8,000g / m². Shell - durable Omni-Stretch[™] nylon / polyester spandex shell with HydrX Pro[™] laminate. Lining - nylon taffeta lining. FXR Dry Vent[™] system - snowproof and moisture resistant chest and side body vent system. F.A.S.T. 3.0[™] - 250g combined F.A.S.T.[™] / FXR Thermal Flex[™] insulation value. F.A.S.T.[™] is perforated at vents for improved breathability. FXR Dry Vent[™] system - snowproof and moisture resistant chest and side body vent system. YKK[®] Vislon[®] front zipper. Heavy duty #8 waterproof zippers at chest pocket and side body vents. YKK[®] zippers at hand pockets. Cold stop front placket with hook and loop / snap closure system. Removable / adjustable hood. Adjustable windskirt. Shock-cord adjustable collar and hem. Adjustable cuffs with lycra inner cuff extensions. Reflective screen prints.

Black/Sky Blue/White

13-90640K4	13-90644K12
13-90641K6	13-90645K14
13-90642K8	13-90646K16
13-90643K10	

Black/Raspberry Fade

13-90655K4	13-90660K14
13-90656K6	13-90661K16
13-90657K8	13-90662K18
13-90658K10	13-90663K20
13-90659K12	



CLOTHING



F.A.S.T.
FLEXIBLE
ADJUSTABLE
STRETCHABLE
THERMAL
INSULATION



F.A.S.T.
Insulated
Combo

Ladies Edge Pant - \$449.95

A.C.M.T. – 20,000mm / 8,000g/m². Shell – M-Series Omni-Stretch 300D polyester shell with HydrX Pro laminate. Seam-sealed in critical areas. Insulation – 175g FXR Thermal Flex fill. Lining – A.C.M.T. seam-sealed lining system with HydrX Pro laminate and integrated venting. FXR Dry Vent System – Snowproof and moisture resistant thigh vent system. Heavy-duty #8 waterproof zippers throughout. Full length waterproof 2-way leg zippers with quick zip drop-seat function. Adjustable waist system. Retention loops for windskirt attachment. Thermal seat / dry seat, and dry knee inserts. Padded knees. Adjustable / removable suspender system with back bib. Reinforced instep and drop down adjustable hem. Storm cuffs with Hook & Loop / snap closure and front / rear boot lace retention system. Back leg length adjusters. Reflective inserts.

Black Ops

- 13-91080K4 13-91084K12
- 13-91081K6 13-91085K14
- 13-91082K8 13-91086K16
- 13-91083K10



F.A.S.T.
Insulated
Combo



Ladies Pulse Jacket - \$429.00

HydrX Pro™ 10,000mm / 8,000g / m². Shell - M-Series Omni-Stretch™ 300d polyester shell with HydrX Pro™ laminate. Lining - nylon taffeta lining with sherpa fleece center back panel. FXR Dry Vent™ system - snowproof and moisture resistant chest pocket vent. F.A.S.T. 3.0™ - 250g combined F.A.S.T.™ / FXR Thermal Flex™ insulation value. YKK® Vislon® front zipper. Heavy duty #8 waterproof zippers at chest pocket. YKK® zippers at hand pockets. Cold stop front placket with magnetic / snap closure system. Removable / adjustable hood. Adjustable windskirt. Shock-cord adjustable collar and hem. Adjustable cuffs with lycra inner cuff extensions. Reflective inserts.

Black/Gold

- 13-92813K4 13-92817K12
- 13-92814K6 13-92818K14
- 13-92815K8 13-92819K16
- 13-92816K10



WOMEN	2/2XS	4/2S	A/S	B/M	16/L	12-SH	12/XXL	14-SH	14/2XL	16/2XL	18/4XL	20/3XL	22/4XL	24/7XL
Chest Circumference	31-32	33-34	35-36	37-38	39-40	41-42	41-42	43-44	43-44	45-46	47-48	49-50	52-53	55-56
Waist Circumference	27-28	29-30	31-33	33-34	35-36	37-38	37-38	39-40	39-40	41-42	43-44	45-46	46-49	51-52
Hip Circumference	32-33	34-35	36-37	38-39	40-41 1/2	42 1/2-44	42 1/2-44	45-46 1/2	45-46 1/2	47 1/2-49	50-51 1/2	52 1/2-54	55 1/2-57	58 1/2-60
Arm Length From Center Back Neck	28 1/2	30 1/4	31	31 3/4	32 1/2	31 1/2	32 7/8	31 1/2	33 1/8	33 1/2	33 7/8	34 1/4	34 1/4	34 1/4
Inseam	28	30	30	30	30 1/2	28 1/2	30 1/2	28	30	29 1/2	29	29	29	29



Black Heather/Mint

8

F.A.S.T.
Insulated
Combo



Charcoal/Heather/White



5

F.A.S.T.
Insulated
Combo

Ladies Fresh Jacket - \$399.00

HydrX™ 5,000mm / 5,000g / m². Shell - durable polyester shell with HydrX™ laminate. Lining - nylon taffeta lining with sherpa fleece center back panel. F.A.S.T. 3.0™ - 250g combined F.A.S.T.™ / FXR Thermal Flex™ insulation value. FXR Dry Vent™ system - snowproof and moisture resistant chest vent system. YKK® Vislon® front zipper. Heavy duty #8 waterproof zippers at chest and hand pockets. Cold stop front placket with magnetic / snap closure system. Removable / adjustable hood. Adjustable windskirt. Shock-cord adjustable bottom hem. Adjustable cuffs with lycra inner cuff extensions. Reflective screen prints.

Black Heather/Mint

13-4460K	4
13-4461K	6
13-4462K	8
13-4463K	10

Charcoal/Heather/White

13-4450K	4	13-4454K	12
13-4451K	6	13-4455K	14
13-4452K	8	13-4456K	16
13-4453K	10		

Ladies Fresh Pant - \$339.00

HydrX™ 5,000mm / 5,000g / m². Shell - durable polyester shell with HydrX™ laminate. Lining - nylon taffeta lining. F.A.S.T. 3.0™ - 150g combined F.A.S.T.™ / FXR Thermal Flex™ insulation value. F.A.S.T.™ is perforated at seat panel for improved breathability. YKK® front and leg zippers. Heavy duty #8 waterproof zippers at hand pockets. Adjustable / removable suspenders. Thermal seat, dry seat, and dry knee inserts. Adjustable waist system. Reinforced instep and drop-down adjustable hem. Storm cuffs with snap closure and front boot lace retention snaps. Back leg length adjuster. Reflective screen prints.

Black Ops

13-92925K	4	13-92929K	12
13-92926K	6	13-92930K	14
13-92927K	8	13-92931K	16
13-92928K	10		

9

Insulated



Ladies Sugar Bib Pant - \$339.00

(Sizes 18-20 \$359.00)

HydrX™ - 2,000mm / 2,000g / m². Shell - durable polyester shell with HydrX™ coating. Seam-sealed in critical areas. Lining - moisture wicking quick-dry mesh lining. Insulation - 225g FXR Thermal Flex™ insulation. YKK® front zipper with placket / snap closure. Knee height YKK® leg zippers. Quick-zip drop-seat function. Adjustable fixed suspenders. Adjustable waist system. Waist / hip and knee flex stretch inserts. Thermal seat and dry seat inserts. Pre-curved knees. Reinforced instep and drop down adjustable hem. Storm cuffs with snap closure and front boot lace retention snaps. 3M™ Scotchlite™ reflective.

Black

13-91193K	4	13-91198K	14
13-91194K	6	13-91199K	16
13-91195K	8	13-91200K	18
13-91196K	10	13-91201K	20
13-91197K	12		



Insulated with F.A.S.T Combo



Black/Charcoal/Grey



Black/Neon Fusion



Black Ops



Insulated with F.A.S.T Combo



Black/Charcoal/Inferno



Black/Charcoal/HiVis

Child/Youth Helium Monosuit

Offering incredible value and warmth, the youth Helium monosuit packs incredible technology including the buoyancy assistance of our F.A.S.T. membrane, elevated protection from moisture, wind and snow with HydrX, and the added warmth of our Thermal Flex blended insulation. More details at mercersmarine.com

Black/Charcoal/Grey

13-19182K.....	2 Child	299.00
13-19183K.....	4 Child	299.00
13-19184K.....	6 Child	329.00
13-19185K.....	8 Child	329.00
13-19186K.....	10 Youth.....	369.00
13-19187K.....	12 Youth.....	369.00
13-19188K.....	14 Youth.....	409.00
13-19189K.....	16 Youth.....	409.00

Black/Neon Fusion

13-19174K.....	2 Child	299.00
13-19175K.....	4 Child	299.00
13-19176K.....	6 Child	329.00
13-19177K.....	8 Child	329.00
13-19178K.....	10 Youth.....	369.00
13-19179K.....	12 Youth.....	369.00
13-19180K.....	14 Youth.....	409.00
13-19181K.....	16 Youth.....	409.00

Black/Charcoal/Inferno

13-19166K.....	2 Child	299.00
13-19167K.....	4 Child	299.00
13-19168K.....	6 Child	329.00
13-19169K.....	8 Child	329.00
13-19170K.....	10 Youth.....	369.00
13-19171K.....	12 Youth.....	369.00
13-19172K.....	14 Youth.....	409.00
13-19173K.....	16 Youth.....	409.00

Child/Youth Recruit Monosuit

Shell - durable 300d sublimated shell with HydrX laminate. 450d shell fabric at knees, instep and hem for extra durability. Seam sealed in critical areas. F.A.S.T. 3.0 insulation. Thigh pockets with flap closure. Knee height YKK leg zippers. Collar with attached hood. Thermal seat, dry seat and dry knee inserts. Youth - One piece storm cuffs with front boot lace retention snap. Child - One piece storm cuffs. Youth - adjustable cuffs. Child - knit cuffs. Back leg length adjuster. 360° 3M Scotchlite Reflective.

Black Ops

13-19300K.....	2 Child	269.00
13-19301K.....	4 Child	269.00
13-19302K.....	6 Child	299.00
13-19303K.....	8 Child	299.00
13-19304K.....	10 Youth.....	339.00
13-19305K.....	12 Youth.....	339.00
13-19306K.....	14 Youth.....	379.00
13-19307K.....	16 Youth.....	379.00

Black/Charcoal/HiVis

13-19310K.....	2 Child	269.00
13-19311K.....	4 Child	269.00
13-19312K.....	6 Child	299.00
13-19313K.....	8 Child	299.00
13-19314K.....	10 Youth.....	339.00
13-19315K.....	12 Youth.....	339.00
13-19316K.....	14 Youth.....	379.00
13-19317K.....	16 Youth.....	379.00

Prices are subject to change. Check our website for up to date prices. www.mercersmarine.com



Black/Raspberry Fade

FXR

8

Insulated with
F.A.S.T. Combo

F.A.S.T.
FLOATATION ASSISTANCE
SUPPORT TECHNOLOGY



Black/Blue/HiVis



Black Camo/Red Fade

Child/Youth CX Monosuit

Ride all-day knowing your children are warm, comfortable and secure when they find themselves wearing a CX monosuit. Featuring the added safety of our floatation assistance membrane found in F.A.S.T.™ and the moisture barrier attributes of a HydrX™ single-layer moisture shield, your kids may never want to come inside. More details at mercersmarine.com.

Black/Raspberry Fade

13-93012K2 Child299.00
13-93013K4 Child299.00
13-93014K6 Child329.00
13-93015K8 Child329.00
13-93016K10 Youth369.00
13-93017K12 Youth369.00
13-93018K14 Youth409.00
13-93019K16 Youth409.00

Black/Blue/HiVis

13-93020K2 Child299.00
13-93021K4 Child299.00
13-93022K6 Child329.00
13-93023K8 Child329.00
13-93024K10 Youth369.00
13-93025K12 Youth369.00
13-93026K14 Youth409.00
13-93027K16 Youth409.00

Black Camo/Red Fade

13-92990K2 Child299.00
13-92991K4 Child299.00
13-92992K6 Child329.00
13-92993K8 Child329.00
13-92994K10 Youth369.00
13-92995K12 Youth369.00
13-92996K14 Youth409.00
13-92997K16 Youth409.00

FXR



Black/Charcoal/Grey

9

Insulated with
F.A.S.T. Combo

F.A.S.T.
FLOATATION ASSISTANCE
SUPPORT TECHNOLOGY



Blue Fade/Black/HiVis

Child/Youth CX Jacket

Stand-out at school, on the trail, or in the backyard with our classic CX Jacket custom designed for youth. Packed with warmth; protection from moisture, wind and snow; bolstered with the added safety of our buoyancy assistance technology found in F.A.S.T.™. More details at mercersmarine.com

Black/Charcoal/Grey

13-18600K2 Child169.00
13-18601K4 Child169.00
13-18602K6 Child199.00
13-18603K8 Child199.00
13-18604K10 Youth229.00
13-18605K12 Youth229.00
13-18606K14 Youth259.00
13-18607K16 Youth259.00

Blue Fade/Black/HiVis

13-18620K2 Child169.00
13-18621K4 Child169.00
13-18622K6 Child199.00
13-18623K8 Child199.00
13-18624K10 Youth229.00
13-18625K12 Youth229.00
13-18626K14 Youth259.00
13-18627K16 Youth259.00





Insulated with F.A.S.T Combo



FXR



Black/Charcoal Fade/HiVis

Black/Blue/Inferno

Black Ops

Child/Youth Helium Jacket

In the heart of winter enjoy knowing your kids are warm and safe in our Helium jacket. Featuring our exclusive Float Assist Safety Technology (F.A.S.T.™), Thermal Flex™ insulation for extreme warmth and our exclusive HydrX™ single layer moisture shield for protection from snow, wind and moisture. More details at mercersmarine.com

Black/Charcoal Fade/HiVis

13-18580K2 Child169.00
13-18581K4 Child169.00
13-18582K6 Child199.00
13-18583K8 Child199.00
13-18584K10 Youth229.00
13-18585K12 Youth229.00
13-18586K14 Youth269.00
13-18587K16 Youth269.00

Black/Blue/Inferno

13-18589K2 Child169.00
13-18590K4 Child169.00
13-18591K6 Child199.00
13-18592K8 Child199.00
13-18593K10 Youth229.00
13-18594K12 Youth229.00
13-18595K14 Youth269.00
13-18596K16 Youth269.00

Black Ops

13-93028K2 Child169.00
13-93029K4 Child169.00
13-93030K6 Child199.00
13-93031K8 Child199.00
13-93032K10 Youth229.00
13-93033K12 Youth229.00
13-93034K14 Youth269.00
13-93035K16 Youth269.00



Insulated with F.A.S.T Combo



Black/Charcoal

Black/Canvas/Steel

Child/Youth Kicker Jacket

Shell - durable 300d polyester shell with HydrX laminate. Lining - Nylon taffeta lining with sherpa fleece center back. F.A.S.T. 3.0 insulation. Lower cargo hand pockets with flap closure. Cold stop front placket with hook and loop / snap closure system. High collar with fixed insulated hood. Shock-cord adjustable hem. Youth - adjustable windskirt. Youth - adjustable cuffs with lycra inner cuff extensions. Child - knit cuffs. 360° 3M Scotchlite Reflective. More details at mercersmarine.com

Black/Charcoal

13-18740K2 Child179.00
13-18741K4 Child179.00
13-18742K6 Child209.00
13-18743K8 Child209.00
13-18744K10 Youth239.00
13-18745K12 Youth239.00
13-18746K14 Youth269.00
13-18747K16 Youth269.00

Black/Canvas/Steel

13-18750K2 Child179.00
13-18751K4 Child179.00
13-18752K6 Child209.00
13-18753K8 Child209.00
13-18754K10 Youth239.00
13-18755K12 Youth239.00
13-18756K14 Youth269.00
13-18757K16 Youth269.00

SHOP 24/7 FROM THE COMFORT OF YOUR OWN HOME

- Up to date Pricing
- New Products
- Stock Status
- Additional product info
- And more



www.mercersmarine.com

CLOTHING

Prices are subject to change. Check our website for up to date prices. www.mercersmarine.com



Insulated with
F.A.S.T Combo

F.A.S.T
FRESH AIR SHELTER TECHNOLOGY™
WINDY PROTECTION



Black Camo/Neon Fusion



Black Heather/Sky/Lilac Fade



Raspberry/Electric Pink Fade

Child/Youth Fresh Jacket

HydrX™ – 5,000mm/5,000g/m². Shell - durable polyester shell with HydrX™ laminate. Lining – nylon taffeta lining with sherpa fleece center back panel. Insulation – 225g combined F.A.S.T.™/ FXR Thermal Flex™ insulation value. YKK® vislon front zipper. YKK® hand pocket zippers with fleece lining. Cold stop front placket with hook and loop/snap closure system. 360 3M™ Scotchlite™ reflective. Removable hood with removable faux fur. Shock cord adjustable bottom hem.

Black Camo/Neon Fusion

13-18690K.....	2 Child	189.00
13-18691K.....	4 Child	189.00
13-18692K.....	6 Child	219.00
13-18693K.....	8 Child	219.00
13-18694K.....	10 Youth.....	249.00
13-18695K.....	12 Youth.....	249.00
13-18696K.....	14 Youth.....	289.00
13-18697K.....	16 Youth.....	289.00

Black Heather/Sky/Lilac Fade

13-18700K.....	2 Child	189.00
13-18701K.....	4 Child	189.00
13-18702K.....	6 Child	219.00
13-18703K.....	8 Child	219.00
13-18704K.....	10 Youth.....	249.00
13-18705K.....	12 Youth.....	249.00
13-18706K.....	14 Youth.....	289.00
13-18707K.....	16 Youth.....	289.00

Raspberry/Electric Pink Fade

13-18680K.....	2 Child	189.00
13-18681K.....	4 Child	189.00
13-18682K.....	6 Child	219.00
13-18683K.....	8 Child	219.00
13-18684K.....	10 Youth.....	249.00
13-18685K.....	12 Youth.....	249.00
13-18686K.....	14 Youth.....	289.00
13-18687K.....	16 Youth.....	289.00



FXR
KIDS

Child/Youth Clutch Pants

With a wide range of colour options stay safe and warm in our FXR® Clutch pant. Featuring our exclusive FXR® F.A.S.T.™ technology and Thermal Flex™ insulation for warmth and flexibility while the zip off leg extensions keeps up with your kid's growth making the pant last longer. More details at mercersmarine.com

Black Ops

13-93124K.....	2 Child	169.00
13-93125K.....	4 Child	169.00
13-93126K.....	6 Child	199.00
13-93127K.....	8 Child	199.00
13-93128K.....	10 Youth.....	229.00
13-93129K.....	12 Youth.....	229.00
13-93130K.....	14 Youth.....	259.00
13-93131K.....	16 Youth.....	259.00

Black/Fuchsia

13-18570K.....	2 Child	169.00
13-18571K.....	4 Child	169.00
13-18572K.....	6 Child	199.00
13-18573K.....	8 Child	199.00
13-18574K.....	10 Youth.....	229.00
13-18575K.....	12 Youth.....	229.00
13-18576K.....	14 Youth.....	259.00
13-18577K.....	16 Youth.....	259.00



Insulated with
F.A.S.T Combo

F.A.S.T
FRESH AIR SHELTER TECHNOLOGY™
WINDY PROTECTION



FXR

9

Insulated with
F.A.S.T Combo



Black/Red



Black/Neon Fusion



Black/Sky/Purple Fade

FXR

Child/Youth Boost Jacket

HydrX™ – 5,000mm/5,000g/m². Shell – durable sublimated 300d polyester shell with HydrX™ laminate. Lining – FXR embossed nylon taffeta lining. Insulation – 225g combined F.A.S.T.™/ FXR Thermal Flex™ insulation value. YKK® vislon front zipper. YKK® hand pocket zippers with fleece lining. Cold stop front placket with hook and loop/snap closure system. 360 3M™ Scotchlite™ reflective. Removable hood. Shock cord adjustable bottom hem.

Black/Red

13-19080K.....	2 Child	169.00
13-19081K.....	4 Child	169.00
13-19082K.....	6 Child	199.00
13-19083K.....	8 Child	199.00
13-19084K.....	10 Youth.....	229.00
13-19085K.....	12 Youth.....	229.00
13-19086K.....	14 Youth.....	259.00
13-19087K.....	16 Youth.....	259.00

Black/Neon Fusion

13-19090K.....	2 Child	169.00
13-19091K.....	4 Child	169.00
13-19092K.....	6 Child	199.00
13-19093K.....	8 Child	199.00
13-19094K.....	10 Youth.....	229.00
13-19095K.....	12 Youth.....	229.00
13-19096K.....	14 Youth.....	259.00
13-19097K.....	16 Youth.....	259.00

Black/Sky/Purple Fade

13-19100K.....	2 Child	169.00
13-19101K.....	4 Child	169.00
13-19102K.....	6 Child	199.00
13-19103K.....	8 Child	199.00
13-19104K.....	10 Youth.....	229.00
13-19105K.....	12 Youth.....	229.00
13-19106K.....	14 Youth.....	259.00
13-19107K.....	16 Youth.....	259.00

CHILD / YOUTH	2	4	6	8	10	12	14	16
Height	23"	35"	31"	45"	48"	41"	52"	55"
Chest Circumference	21	23	25	27	29	31	33	35
Waist Circumference	18	20	22	24	26	28	30	32
Hip Circumference	21	23	25	27	29	31	33	35
Arm Length From Center Back Neck	17 1/2	19 1/2	21 1/2	23 1/2	25 1/2	27 1/2	29	30 1/2
Inseam	17	19	21	23	25	27	29	31



CLOTHING

Prices are subject to change. Check our website for up to date prices. www.mercersmarine.com

FXR



FXR Mens Leather Gauntlet Glove

Thinsulate® 300g back of hand/200g palm and forchettes. Full grain cowhide leather construction. Reinforced full grain leather palm and thumb. HydrX Pro™ Waterproof/breathable membrane. Foam padding on back of hand and knuckles for added impact protection. Polar fleece lining. Aggressive pre-curved finger design for precision fit and dexterity. Wrist strap adjuster with shockcord adjustable storm cuff. 3M™ Scotchlite™ reflective

13-3845K.....Sm	185.00
13-3846K.....Med	185.00
13-3847K.....Lg	185.00
13-3848K.....XL	185.00
13-3849K.....2X	185.00
13-3850K.....3X	185.00

FXR



FXR Mens Combat Mitt

Thinsulate® 300g back of hand and thumb/200g palm insulation. Durable nylon shell construction. Polar fleece lining with separate inner finger chambers. Reinforced goat leather palm construction. HydrX Pro™ Waterproof/breathable Membrane. Foam padding on back of hand and knuckles for added impact protection. Wrist strap adjuster with shock cord adjustable storm cuff. 3M™ Scotchlite™ reflective

13-5031K.....Sm	139.95
13-5032K.....Med	139.95
13-5033K.....Lg	139.95
13-5034K.....XL	139.95
13-5035K.....2X	139.95

FXR



FXR Mens Leather Claw Mitt

Thinsulate® 300g Back Of Hand/200g Palm. Full Grain Cowhide Leather Construction. Reinforced Full Grain Leather Palm And Thumb. Waterproof/Breathable Hipora® Membrane Liner. Polar Fleece Lining With Separate Inner Finger Chambers. Wrist Strap Adjuster With Shockcord Adjustable Storm Cuff. Silicone Traction Palm. Aggressive Pre-Curved Finger Design For Precision Fit And Dexterity. 3M™ Scotchlite™ Corded Reflective.

13-5010K.....Sm	185.00
13-5011K.....Med	185.00
13-5012K.....Lg	185.00
13-5013K.....XL	185.00
13-5014K.....2X	185.00
13-5015K.....3X	185.00

FXR



FXR Mens Heated Recon Glove

Thinsulate® 300g back of hand/200g palm and forchettes. 3 Stage thermal heat setting controlled by exterior gauntlet easy control button. Heat element tracks around each finger on the backside of glove providing up to 5 Hours of heat (battery life depends on power setting and conditions). Durable nylon laminated shell construction. Reinforced full grain leather palm and thumb waterproof/breathable Hipora® membrane liner. Polar fleece lining. Wrist strap adjuster with shockcord adjustable storm cuff. Aggressive pre-curved finger design for precision fit and dexterity. High visibility 3m™ Scotchlite™ flat reflective. Rechargeable 7.4V lithium polymer batteries and north american wall charger included.

13-3859K.....Sm	389.00
13-3860K.....Med	389.00
13-3861K.....Lg	389.00
13-3862K.....XL	389.00
13-3863K.....2X	389.00
13-3864K.....3X	389.00

FXR



FXR Transfer Gloves

Thinsulate 150g back of hand and thumb insulation. HydrX Pro Waterproof/breathable Membrane. Snug-fit zipper closure. Durable nylon shell construction. Reinforced full-grain leather palm and thumb. Under-sleeve compatible short cuff with built-in gator. Foam padding on back of hand and knuckles for added impact protection. High-strength nylon pull-on loop. Polar fleece lining. Soft gauge index finger TPR goggle wipe. Aggressive pre-curved finger design for precision fit and dexterity. Goggle and nose wipe suede thumbs.

13-5130K.....Sm	129.95
13-5131K.....Med	129.95
13-5132K.....Lg	129.95
13-5133K.....XL	129.95
13-5134K.....2X	129.95

FXR



FXR Half Finger Glove

Moisture-wicking knit wool. Rib-knit cuff

13-5125K.....Med	49.95
13-5126K.....Lg	49.95
13-5127K.....XL	49.95



FXR**FXR**

Black/HiVis

Black Ops

Blue/HiVis

Black/White

Black/Red

Mens Fuel Glove - \$149.95

Thinsulate® 300g back of hand/250g thumb/200g palm and forchette insulation. Durable nylon shell construction. Reinforced full grain leather palm and thumb. Waterproof/breathable Hipora® membrane liner. Polar fleece lining. Wrist strap adjuster with shockcord adjustable storm cuff. Soft gauge index finger tpr goggle wipe. Goggle wipe suede thumb. Aggressive pre-curved finger design for precision fit and dexterity. 3M Scotchlite corded reflective. Recommended to go up one size when ordering.

Color	Size	Sm	Med	Lg	XL	2X	3X
Black/HiVis		13-5094K	13-5095K	13-5096K	13-5097K	13-5098K	13-5099K
Black Ops		13-5065K	13-5066K	13-5067K	13-5068K	13-5069K	13-5070K
Blue/HiVis		13-5052K	13-5053K	13-5054K	13-5055K	13-5056K	13-5057K
Black/White		13-5080K	13-5081K	13-5082K	13-5083K	13-5084K	13-5085K
Black/Red		13-5045K	13-5046K	13-5047K	13-5048K	13-5049K	13-5050K

FXR

Black/Charcoal

Black/White

Black/Fuchsia

Black/Raspberry

Ladies FXR Fusion Glove - \$139.95

Thinsulate® 300g back of hand/250g Thumb/200g palm and forchette insulation. Durable nylon shell construction. Reinforced full grain leather palm and thumb. Waterproof/breathable Hipora® membrane liner. Polar fleece lining. Wrist strap adjuster with shock cord. Adjustable storm cuff. Soft gauge index finger tpr goggle wipe. Goggle wipe suede thumb. Aggressive pre-curved finger design. 3M™ Scotchlite™ corded reflective.

Color	Size	XS	Sm	Med	Lg	XL
Black/Charcoal		13-6544K	13-6545K	13-6546K	13-6547K	13-6548K
Black/White		13-6529K	13-6530K	13-6531K	13-6532K	13-6533K
Black/Fuchsia		13-6524K	13-6525K	13-6526K	13-6527K	13-6528K
Black/Raspberry		13-6518K	13-6519K	13-6520K	13-6521K	13-6522K

Prices are subject to change. Check our website for up to date prices. www.mercersmarine.com

CLOTHING**405**



FXR Ladies Combat Mitt

Thinsulate 300g back of hand/250g thumb/200g palm and fourchette insulation. Durable nylon shell construction. Polar fleece lining with separate inner finger chambers. Reinforced goat leather palm and thumb. HydrX Pro Waterproof/breathable Membrane. Foam padding on back of hand and knuckles for added impact protection. Wrist strap adjuster with shock cord adjustable storm cuff. Back of hand padded fleece wipe. 3M Scotchlite reflective.

Black/Charcoal

13-4805KXS125.95
13-4806KSm125.95
13-4807KMed125.95
13-4808KLg125.95
13-4809KXL125.95

Black/Fuchsia

13-4810KXS125.95
13-4811KSm125.95
13-4812KMed125.95
13-4813KLg125.95
13-4814KXL125.95

FXR



KIDS



Child/Youth Helix Mitt

Thinsulate 300g back of hand and thumb/200g palm insulation. Durable nylon shell construction. Reinforced full grain leather palm construction. Waterproof/breathable Hipora membrane liner. Polar fleece lining. Wrist strap adjuster with shock cord. Adjustable storm cuff. Back of hand padded fleece wipe. 3M™ Scotchlite™ reflective.

Child - Black

13-4750KSm75.95
13-4751KMed75.95
13-4752KLg75.95

Childs - Fuchsia

13-4755KSm75.95
13-4756KMed75.95
13-4757KLg75.95

Youth - Black

13-4770KSm79.95
13-4771KMed79.95
13-4772KLg79.95

Youth - Fuchsia

13-4773KSm79.95
13-4774KMed79.95
13-4775KLg79.95



FXR

KIDS



Child/Youth Helix Glove

Thinsulate 300g back of hand and thumb/300g forchettes/200g palm insulation. Durable nylon shell construction. Reinforced full grain leather palm. Waterproof/breathable Hipora membrane liner. Polar fleece lining. Shockcord adjustable storm cuff. Back of hand padded fleece wipe. 3M Scotchlite corded reflective.

Black

Child

13-5000KSm75.95
13-5001KMed75.95
13-5002KLg75.95

Fuchsia

Child

13-5005KSm75.95
13-5006KMed75.95
13-5007KLg75.95

Youth

13-4790KSm79.95
13-4791KMed79.95
13-4792KLg79.95

Youth

13-4794KSm79.95
13-4795KMed79.95
13-4796KLg79.95





FXR Backshift BOA Boot - \$529.00

BOA H3 Coiler reel. Single anti-slip lace with molded lace sliders for easy tie & go use. HydrX Pro Membrane. Rated to -75° C with 1200g insulation. Molded inner heel flex insert for backward flex control and impact support. Slip-on removable liner with micro fur lining. Flex inserts for positive fit & feel, and maximum comfort. Heavy-duty 2mm genuine rubber reinforcements. Front & rear pant cuff attachment system. Molded low-profile toe box. 20mm thick EVA midsole for maximum impact absorption. FXR High traction outsole with toe and heel kick. Achilles and calf cushion support.

14-2246K.....8	14-2249K..... 11
14-2247K.....9	14-2250K 12
14-2248K.....10	14-2251K.....13



FXR X-Cross Speed Boot - \$299.00

Speed Lace with Lace Hook secure system. 2- Piece form-fitting tongue construction for Positive fit and maximum comfort. HydrX Membrane. New sewn-in molded speed lace hooks for quick tie and release. Rated to -40° C with 600g insulation. Fixed liner with fur lining. 20mm thick EVA midsole for maximum. Genuine rubber reinforcement at the toe cap and inside. Minimal seams in sled-contact area. Webbing pull strap. Achilles and calf cushion support.

14-2260K.....8	14-2263K..... 11
14-2261K.....9	14-2264K 12
14-2262K.....10	14-2265K.....13



FXR X-Cross Pro BOA Boot - \$369.00

BOA® Single M3 reel Features. HydrX Membrane. 2-Piece form-fitting tongue construction for Positive Fit and Maximum Comfort. Engineered to have extremely positive fit & feel, with both maximum flexibility, stability and protection. FXR high traction outsole with toe and heel kick. Rated to -40° C with 600g insulation. Fixed liner with fur lining. Minimal seams in sled-contact areas. 20mm thick EVA midsole for maximum. Genuine rubber reinforcement at the toe cap and instep. Achilles and calf cushion support.

14-2253K.....8	14-2256K 11
14-2254K.....9	14-2257K 12
14-2255K.....10	14-2258K.....13



FXR X-Cross Pro Ice Boot - \$319.00

Rated to -45° C with 600g insulation. HydrX Membrane. Slip-on convenience. FXR high traction outsole. Fixed liner with fur lining. Toe kick - clean snow and ice with ease. BTO Thermostatic Midsole Insert. Diamond grid genuine rubber inserts. Ultimate heel holder design.

Mens Ice Pro

14-2300K.....8	14-2303K 11
14-2301K.....9	14-2304K 12
14-2302K.....10	14-2305K.....13

Ladies Ice Pro

14-2308K.....6	14-2312K 10
14-2309K.....7	14-2313K 11
14-2310K.....8	14-2314K 12
14-2311K.....9	



KIDS



Kids Svalbard Boot - \$89.95

Fully Waterproof, Polymer Boot Construction. 100% High Quality, Lightweight EVA Material. Removable Liner. Flex Rated To -30 Degrees Celsius. Cold Rated To -30 Degrees Celsius. Nylon Gaiter At Top With Drawstring.

Black

14-2281K6/7	14-2285K 1/2
14-2282K8/9	14-2286K 2/3
14-2283K10/11	14-2287K 4/5
14-2284K 12/13	

Fuchsia

14-2274K6/7	14-2278K 1/2
14-2275K8/9	14-2279K 2/3
14-2276K10/11	14-2280K 4/5
14-2277K 12/13	



Black Ops



Black/White



Black/HiVis



Black/Pink



Black/Red



Black/Blue

FXR Torque Team Helmet - \$199.00

SHELL: Lightweight, strong, advanced polymer alloy. HELMET PEAK: Reduces lift/drag at high speeds & protects from snow & roost. PROTECTION: Quick-Release, easy adjust buckle. Extended rubber nose roost guard. COMFORT: Hygienically-treated, removable, washable, moisture-wicking, comfort liner. Integrated, removable breath-box-ready tabs.

Color	Size	XS	Small	Medium	Large	XL	2X
Black Ops		13-19768K	13-19769K	13-19770K	13-19771K	13-19772K	13-19773K
Black/White		13-92244K	13-92245K	13-92246K	13-92247K	13-92248K	13-92249K
Hi-Vis		13-93144K	13-93145K	13-93146K	13-93147K	13-93148K	13-93149K
Black/Pink		13-92215K	13-92216K	13-92217K	13-92218K	13-92219K	-
Black/Red		13-93168K	13-93169K	13-93170K	13-93171K	13-93172K	13-93173K
Black/Blue		-	13-92209K	13-92210K	13-92211K	13-92212K	13-92213K



FXR Maverick X Helmet (Heated Shield) - \$529.00

SHELL: Lightweight, strong, advanced polymer alloy. Increased shield tab size for easier use with larger winter gloves. Updated Lock & Seal shield technology. PEAK: Strong removable peak reduces lift / drag at high speeds and protects from sun and roost. Side covers can be switched out with peak. PROTECTION: Quick-release, easy-adjust buckle. Dual-density EPS liner. Stainless Steel Impact-resistant chin-bar latch system with new Posi-Lock guide. Ultra-high lift chin bar with glove-friendly thumb-release button. Chin-Bar and shield nest into the peak to prevent hooking when open. Meets and exceeds National Safety Regulations. SHIELD: Integrated drop-down sun-shade. Electrically heated anti-fog, anti-scratch, UV filtering, distortion-free, dual-layer face shield. Easy-to-use face shield retention system. Includes power cord. COMFORT: Integrated, removable breath box / chin skirt system. Hi-flow adjustable air ventilation system with integrated drag reduction vent-spoiler. Hygienically-treated, removable, washable, moisture-wicking, comfort liner.

Black/Titanium

13-3050KSm	13-3053K XL
13-3051KMed	13-3054K 2X
13-3052KLg	13-3055K 3X





COMES WITH GOGGLES



FXR Torque Cold Stop QRS Helmet

INCLUDES:

- Torque Team Black Ops helmet with breath box, removable vent plugs, and Quick Release buckle.
- Comes with Maverick Black Ops goggle with FXR Quick-Release strap.

SHELL

- Lightweight, strong, advanced polymer alloy
- Reduces lift/drag at high speeds & protects from snow & roost

PROTECTION

- Extended rubber nose roost guard
- Quick release, easy adjust buckle
- Extended rubber nose roost guard

COMFORT

- Hygienically-treated, removable, washable, moisture-wicking, comfort liner
- Integrated, removable breath-box-ready tabs

Black Ops

13-3030K.....Sm	339.00
13-3031K.....Med	339.00
13-3032K.....Lg.....	339.00
13-3033K.....XL.....	339.00
13-3034K.....2X.....	339.00



HEATED SHIELD



FXR Torque X Helmet (Heated Shield)

SHELL: Lightweight, strong, advanced polymer alloy.

PEAK: Reduces lift/drag at high speeds & protects from sun & roost. SHIELD: Anti-fog, anti-scratch, UV filtering, distortion-free shield. Integrated Drop-down sun-shade included. Electrically heated dual-layer face shield. Includes power cord. Lock + Seal technology.

PROTECTION: Quick-Release, easy-adjust buckle. Dual-density EPS liner. Adjustable fit breath box. Meets and exceeds National Safety Regulations. COMFORT: Easy open, front nose guard vent. Hygienically-treated, removable, washable, moisture-wicking, comfort liner.

Black Ops - HEATED SHIELD

13-92271K.....XS.....	419.00
13-92272K.....Sm.....	419.00
13-92273K.....Med.....	419.00
13-92274K.....Lg.....	419.00
13-92275K.....XL.....	419.00
13-92276K.....2X.....	419.00



HEATED SHIELD

FXR



FXR Maverick Electric Goggle (Battery)

Electric heated lens (uses rechargeable on-board battery pack)

Impact-resistant, dual-pane, pre-curved polycarbonate snow lens. Premium anti-scratch, anti-fog, & UV lens coatings. Soft, anti-scratch battery pack. Triple density, moisture-wicking, contoured face foam. Premium strap with triple silicone grips. Removable nose piece. Soft storage/cleaning pouch included. Includes battery charger.

13-93243K329.95



HEATED SHIELD



FXR Maverick Electric Goggle (Corded)

Electric heated lens (uses 12V power supply)

Impact-resistant, dual-pane, pre-curved polycarbonate snow lens. Premium anti-scratch, anti-fog, & UV lens coatings. Outrigger frame for perfect fit & tension. Triple density, moisture-wicking, contoured face foam. Premium strap with triple silicone grips. Removable nose piece. Soft storage/cleaning pouch included. Includes power cord.

13-93241K219.95



FXR Helmet Bag

Large main compartment with spare visor pocket and padded surfaces for added helmet protection. 2 large side pockets with goggle pouches. Goggle chamois, and key ring. 1 large end pocket with pouches for helmet-cams and accessories. Water-shedding drainage system. Heavy duty wear-resistant outer base. Easy access, dual zip, cover door. Large comfortable rubberized carry-handle. Bag weight 2.0 lbs

13-22721K.....49.95



FXR Combat Cold Stop Clear Goggle

Windproof, oversized, Quad-density, moisture-wicking, contoured face foam & fabric. Low-rise, impact-resistant, dual-pane, pre-curved polycarbonate snow lens. Premium anti-scratch, anti-fog, & UV lens coatings. High-Quality printed strap with triple silicone grips. Outrigger frame for perfect fit & tension. Soft storage / cleaning pouch included.

Black Ops

13-2886K.....139.95

CLOTHING





KIDS

FXR Youth Legion Helmet

SHELL: Lightweight, strong, advanced polymer alloy
HELMET PEAK: Adjustable ultra hi-flow shape reduces drag & protects from snow & roost. PROTECTION: Quick-Release, easy-adjust buckle. Dual-density EPS liner. Extended rubber nose frost & roost guard. Rear diffuser to transfer impact load to compatible neck braces. Meets and exceeds DOT safety regulations. COMFORT: Excellent fit on any youth head. Wear-resistant cheek pads. High-flow adjustable air ventilation system. Integrated removable breath box available. Hygienically-treated, removable, washable, moisture-wicking, comfort liner.

Black Ops	
13-93192K.....Sm	169.00
13-93193K.....Med	169.00
13-93194K.....Lg	169.00



KIDS

FXR Youth Nitro Core Helmet

SHELL: Lightweight, strong, advanced polymer alloy
SHIELD: Anti-fog, anti-scratch, UV filtering, distortion-free shield. Easy-to-use face shield retention system. PROTECTION: Dual-density EPS liner. Meets and exceeds National Safety Regulations. COMFORT: Excellent fit on any youth head. Quick-Release, easy-adjust buckle. High-flow adjustable air ventilation system. Hygienically-treated, removable, washable, moisture-wicking, comfort liner.

Black Ops		Black/HiVis	
13-4609K.....Sm	229.00	13-4618K.....Sm	229.00
13-4610K.....Med	229.00	13-4619K.....Med	229.00
13-4611K.....Lg	229.00	13-4620K.....Lg	229.00



KIDS



FXR Youth Maverick Goggle

New large eyepoint for maximum viewing area. Impact-resistant, dual-pane, pre-curved polycarbonate snow lens. Premium anti-scratch, anti-fog, & UV lens coatings. Integrated outrigger for positive fit & tension. Moisture-wicking face fabric. Triple density, moisture-wicking, contoured face foam. Premium strap with Triple silicone grips. Removable nose piece. Soft storage/cleaning pouch included.

Black Ops		Electric Pink	
13-93245K.....	59.95	13-93244K.....	59.95



CLOTHING



FXR Maverick Goggle

Impact-resistant, dual-pane, pre-curved polycarbonate snow lens. Premium anti-scratch, anti-fog, & UV lens coatings. Moisture-wicking face fabric. Triple density, moisture-wicking, contoured face foam. Premium strap with triple silicone grips. Removable nose piece. Soft storage/cleaning pouch included.



Black Ops

Black Ops
13-2900K.....109.95



HiVis

HiVis
13-2901K.....109.95



Pink
13-2907K.....109.95



Blue

Blue
13-2908K.....109.95



White

White
13-2906K.....109.95



Black/Charcoal/HiVis

Black/Charcoal/HiVis
13-2905K.....109.95



Red
13-2902K.....109.95

FXR Combat Goggle

Low-rise, vented, dual-pane, impact-resistant, pre-curved polycarbonate snow lens. Premium anti-scratch, anti-fog, & UV lens coatings. High-Quality printed strap with triple silicone grips. Outrigger frame for perfect fit & tension. Triple density, moisture-wicking, contoured face foam & fabric. Removable nose piece. Soft storage/cleaning pouch included.

FXR



Black Ops

Black Ops
13-2880K.....139.95



Black/White

Black/White
13-2881K.....139.95



HiVis

HiVis
13-2882K.....139.95



Ignition

Ignition
13-2883K.....139.95

CLOTHING



FXR Ice Pro Towel

One size and 100% cotton

13-93203K.....21.95



FXR Turbo Socks

2 pair per pack. Acrylic/nylon blend wicks moisture. Lycra for increased stretch and shape retention. Ribbed arch and ankle support. Cushion loop construction. Elastic welt cuff top prevents slippage. Extra padding on heel, toe and arch.

13-93200K2 Pairs per Pk.....33.95



FXR Cozy Mitt

Soft acrylic chunky knit. Microfleece lining for extra warmth. Fold up rib cuff with wrapped label.

13-19886K.....29.95



Black/Charcoal/White

Black/Red

Black/Charcoal/HiVis

Black Ops

Black/Charcoal/Electric Pink

Shredder Balaclava

FXR proprietary 4-way stretch mapped wind-stop system. Ultra lightweight brushed inner polyester-spandex fabrication. Blocks wind to dramatically reduces frostbite risk due to exposure in the critical collar to helmet gap.

13-5018K	Black/Charcoal/White (Small)	45.99
13-5020K	Black/Charcoal/White (Large)	45.99
13-5022K	Black/Red (Small)	45.99
13-5023K	Black/Red (Large)	45.99
13-5024K	Black/Charcoal/Hi-Vis (Small)	45.99
13-5025K	Black/Charcoal/Hi-Vis (Large)	45.99
13-5026K	Black Ops (Small)	45.99
13-5027K	Black Ops (Large)	45.99
13-5036K	Black/Charcoal/Electric Pink (Small)	45.99
13-5037K	Black/Charcoal/Electric Pink (Large)	45.99



Black/Orange



Black/Pink



Black/HiVis



Canvas



Rockstar

Trapper Hat

Coated Nylon Outer Shell. Faux Fur Lining. Optional Under-Chin Clip Or Over-Head Clip. Removable Snap-On Vented Mask. Embroidered Logos.

13-3820K	Black/Orange (Sm/Med)	64.95
13-3821K	Black/Orange (Lg/XL)	64.95
13-3829K	Black/Pink (Sm/Med)	64.95
13-3830K	Black/Pink (Lg/XL)	64.95
13-3835K	Black/HiVis (Sm/Med)	64.95
13-3836K	Black/HiVis (Lg/XL)	64.95
13-3822K	Canvas (Sm/Med)	64.95
13-3823K	Canvas (Lg/XL)	64.95
13-3838K	Rockstar (Lg/XL)	64.95





FXR

FXR Ice-Pro Neck Warmer

Polyester knit outer with DWR coating. Thick sherpa lining for maximum warmth. 9" height x 22" circumference.

13-4535K.....One Size27.95



FXR

FXR Infinite Neck Warmer

Soft acrylic jacquard knit. One size fits all.

13-5030K.....Black/White22.95



Charcoal/Black



Canvas/Black

FXR

FXR



Cold Stop Chest Warmer

250g micro fleece body with woven front chest wind stop. Lycra mock neck with front plastisol screen for extra wind protection at neck.

13-4541K.....One Size35.95



Black



Inferno



Candy

FXR Helium Neck Gaiters

180gsm soft polyester/spandex knit. Brushed on the inside for comfort. Breathable and quick-drying. 20" length x 20" circumference. Wear as a neck gaiter, balaclava, headband, beanie etc.

13-4562K.....Black.....27.95

13-4563K.....Inferno27.95

13-4564K.....Candy27.95



Grey/Charcoal



Inferno/Slate



Slate/Grey

FXR



FXR Anti-Fog Balaclava

Low-profile nose mask diverts breath down, preventing fogging. Poly-elastane construction for mild to mid-weather riding. Dual layer wind-block chin & neck. Flat lock stitching for comfort and durability.

13-5017KLg59.95

FXR



FXR Tenacious Balaclava

80% merino content provides maximum warmth when wet. Lightweight 180gsm premium knit. Superior antibacterial and anti-odor properties. Maximum anti-pill and anti-static performance. Dries rapidly. Screen printed logos.

13-93202KLg39.95

FXR Neck Gaiters

180gsm 92% polyester / 8% spandex knit with anti microbial finish. Sunshield™ 50+ UPF rating. Full sublimation print

13-4555K.....Charcoal/Black29.95

13-4556K.....Canvas/Black.....29.95

13-4557K.....Grey/Charcoal29.95

13-4558K.....Inferno/Slate.....29.95

13-4559K.....Slate/Grey.....29.95

FXR

CLOTHING



Black/Charcoal/Orange



Black Ops



Fuchsia/Black



Black/Charcoal/HiVis

FXR RIDE PACK

Removable, breathable, suspension system easily converts from ride to casual configuration. External shovel blade and handle storage. X-system padded chest straps allow increased arm dexterity and comfort. Load-spreading kidney belt with pockets. Stowable waterproof shell cover. Fleece lined goggle storage. Full access clamshell zipper main compartment. Adjustable cargo sinch straps. Organizer pockets for cargo. External water and snow probe pocket with ties. 19" X 13" x 8" | 30L capacity.

13-4547K	Black/Charcoal/Orange	179.95
13-4544K	Black Ops.....	179.95
13-4545K	Fuchsia/Black	179.95
13-4548K	Black/Charcoal/HiVis	179.95

FXR



FXR Gear Bag

Heavy-duty 900d dobby shell. Padded shoulder strap. Hand straps with padded velcro connector. Large grommets for venting.
40" X 18" x 18" | 180L capacity
13-4549K.....239.00



Cold Stop Anti-Fog Mask

Lightweight neoprene construction. Fleece in critical areas. Full neck coverage. Two layer fleece construction. Front printed polyester wind stop. Lycra mock neck. Full upper chest coverage. Hook & loop adjusters. Adjustable metal nose piece.
13-4540K.....One Size45.95

FXR



FXR TACTIC SHOVEL

Extends to 37" (94cm). Serrated ice-breaker edge. Reconfigurable blade (for shoveling or scooping). Built in 13.5" (35cm) Cross-cut saw blade. Steel reinforced ergonomic handle. Lightweight forged aluminum construction.
13-92281KBlack79.95
13-92282KFuchsia79.95

FXR



FXR Duffel Bag

Heavy-duty shell. Padded shoulder strap. Two-way top zipper and large zippered side pouch. Zippered end compartments.
25" X 12" x 12" , 50L capacity
13-4550K.....119.95





Black/HiVis



Grey/Black



Grey Heather



FXR

Black/Pink



Black/Pink



Black/Orange



Black/Fuchsia

Ocean



Grey/Orange



Black Ops



FXR Excursion Beanie

Wool/acrylic blend with polyester microfleece lining. Fold up rib cuff with wrapped label. Top 3" pompom.

13-93229K.....Black/Hi-Vis	29.95	
13-93230K	Grey/Orange	29.95
13-93225K.....Black Ops	29.95	

FXR Infinite Beanie

Soft acrylic knit. Woven front label. Classic skull fit.

13-93209K.....Grey/Black	29.95
13-93207K.....Black/Pink.....	29.95
13-93208K.....Black/Orange	29.95
13-93210K.....Black/Fuchsia	29.95



Dusty Rose

FXR Sonic Beanie

Soft acrylic knit with pompom. Classic skull fit. Fold up rib cuff with wrapped label.

13-19891K.....Grey Heather.....	29.95
13-19896K.....Black/Pink.....	29.95
13-19895K.....Ocean	29.95
13-93231K.....Dusty Rose	29.95

Grey/Black



Grey/HiVis



Orange/Black

Black/Pink



FXR Race Division Beanie

Soft acrylic jacquard knit. Classic skull fit.

13-19898K.....Grey/Black	29.95
13-19899K.....Grey/HiVis.....	29.95
13-19900K.....Orange/Black	29.95
13-19901K.....Black/Pink.....	29.95

SHOP 24/7 FROM THE COMFORT OF YOUR OWN HOME

- Up to date Pricing
- New Products
- Stock Status
- Additional product info
- And more



www.mercersmarine.com



FXR CLOTHING

Klim

Klim



CLOTHING



Railslide Monosuit (INSULATED)

Engineered from the ground up for the modern crossover rider, the Railslide one-piece is at home carving backcountry powder and flying down groomed trails. With legendary KLIM one-piece functionality, lightweight insulation to cut the chill and adjustable ventilation, the Railslide is ready to adapt to a wide range of conditions right out of the box. See full details online at www.mercersmarine.com

Colour: Black/Grey (Asphalt)

13-4160J.....Med	939.00
13-4161J.....Lg	939.00
13-4162J.....XL	939.00
13-4163J.....2X	939.00
13-4164J.....3X	979.00

Colour: Black

13-4166J.....Med	939.00
13-4167J.....Lg	939.00
13-4168J.....XL	939.00
13-4169J.....2X	939.00
13-4170J.....3X	979.00



Keweenaw Parka (INSULATED)

Klim went back to the drawing board to rebuild Keweenaw into the warmest, most versatile and durable trail jacket. Engineered from rider feedback and extensive testing, it is purpose-built to help you adapt to extreme conditions with 3-in-1 insulation and offer better safety on frozen lakes. Keweenaw keeps you on the gas through all conditions, all season long. See full details online at www.mercersmarine.com

Colour: Heritage

13-3910J.....Sm	669.00
13-3911J.....Med	669.00
13-3912J.....Lg	669.00
13-3913J.....XL	669.00
13-3914J.....2X	669.00
13-3915J.....3X	709.00

Colour: Black

13-3917J.....Sm	669.00
13-3918J.....Med	669.00
13-3919J.....Lg	669.00
13-3920J.....XL	669.00
13-3921J.....2X	669.00
13-3922J.....3X	709.00



Heritage

Black/Grey

Keweenaw Pant (INSULATED)

Klim went back to the drawing board to rebuild Keweenaw into the warmest, most durable trail bib they could. Engineered from rider feedback and extensive testing, it's purpose built to help you adapt to extreme conditions and stay safer on frozen lakes. Keweenaw keeps you on the gas through all conditions, all season long. For more details go to www.mercersmarine.com

Colour: Heritage

13-3950J.....Sm	669.00
13-3951J.....Med	669.00
13-3952J.....Lg	669.00
13-3953J.....XL	669.00
13-3954J.....2X	669.00
13-3955J.....3X	709.00

Tall Sizes

13-3957J.....Lg (Tall)	695.00
13-3958J.....XL (Tall)	695.00
13-3959J.....2X (Tall)	695.00

Short Sizes

13-3960J.....Lg (Short)	669.00
13-3961J.....XL (Short)	669.00
13-3962J.....2X (Short)	669.00
13-3963J.....3X (Short)	709.00

Colour: Black/Grey

13-3965J.....Sm	669.00
13-3966J.....Med	669.00
13-3967J.....Lg	669.00
13-3968J.....XL	669.00
13-3969J.....2X	669.00
13-3970J.....3X	709.00

Tall Sizes

13-3972J.....Lg (Tall)	695.00
13-3973J.....XL (Tall)	695.00
13-3974J.....2X (Tall)	695.00

Short Sizes

13-3975J.....Lg (Short)	669.00
13-3976J.....XL (Short)	669.00
13-3977J.....2X (Short)	669.00
13-3978J.....3X (Short)	709.00



Klimature Parka (INSULATED)

Fully redesigned from the ground up, we built the Klimature Jacket to excel in long days blasting through the woods and across frozen lakes. Now with improved insulation, integrated safety features, and added durable overlays you get comfort and peace of mind for full seasons of trail riding. For more details go to www.mercersmarine.com

Colour: Black/Metallic Silver

13-4070J.....	Sm	539.00
13-4071J.....	Med	539.00
13-4072J.....	Lg	539.00
13-4073J.....	XL	539.00
13-4074J.....	2X	539.00
13-4075J.....	3X	579.00
13-4076J.....	4X	579.00
13-4077J.....	5X	579.00

SHOP 24/7 FROM THE COMFORT OF YOUR OWN HOME

- Up to date Pricing
- New Products
- Stock Status
- Additional product info
- And more



www.mercersmarine.com



Klimature Pant (INSULATED)

Fully redesigned from the ground up, we built the Klimature Bib to excel in long days blasting through the woods and across frozen lakes. Now with improved insulation, integrated safety features, and added durable overlays you get comfort and peace of mind for full seasons of trail riding. For more details go to www.mercersmarine.com

Colour: Metallic Silver

13-4138J.....	Sm	539.00
13-4139J.....	Med	539.00
13-4140J.....	Lg	539.00
13-4141J.....	XL	539.00
13-4142J.....	2X	539.00
13-4143J.....	3X	579.00
13-4144J.....	4X	579.00
13-4145J.....	5X	579.00
Tall Sizes		
13-4146J.....	Lg (Tall)	565.00
13-4147J.....	XL (Tall)	565.00
13-4148J.....	2X (Tall)	565.00
Short Sizes		
13-4149J.....	Lg (Short)	539.00
13-4150J.....	XL (Short)	539.00
13-4151J.....	2X (Short)	539.00
13-4152J.....	3X (Short)	579.00

Kaos Pant (INSULATED)

The improved Kaos Pant for the those who ride fast and light, and value reduced bulk with maximum warmth. Focusing on streamlined construction for warmth without added bulk, and intuitive features gives Kaos the all-day comfort needed for full seasons of riding. For more details go to www.mercersmarine.com



Kaos Jacket (INSULATED)

A fully redesigned Kaos Jacket for the those who ride fast and light, and value reduced bulk with excellent warmth. Focusing on streamlined construction for minimized bulk, high warmth, and intuitive features gives Kaos the all-day comfort needed for full seasons of riding. For more details go to www.mercersmarine.com

Colour: Asphalt

13-4200J.....	Sm	469.00
13-4201J.....	Med	469.00
13-4202J.....	Lg	469.00
13-4203J.....	XL	469.00
13-4204J.....	2X	469.00
13-4205J.....	3X	509.00



Colour: Asphalt

13-4220J.....	Sm	469.00
13-4221J.....	Med	469.00
13-4222J.....	Lg	469.00
13-4223J.....	XL	469.00
13-4224J.....	2X	469.00
13-4225J.....	3X	509.00





Floatation



Rift Jacket (INSULATED)

In pursuit of enhanced winter safety, we've engineered the Rift Jacket to offer floatation assistance, protection and comfort in the extreme conditions trail riders face. This is the first float assist GORE-TEX jacket in the world and it doesn't need to be used with floatation bibs to work properly. Ascent Float System (AFS) is a flexible, breathable closed cell foam that we integrated in specially mapped channels that offer floatation benefits without compromising mobility and comfort. AFS foam doesn't absorb water and provides significant insulating properties for warmth on top of the standard insulation. The Rift Jacket is a comprehensive trail snowmobile jacket for riders looking to maximize every winter riding experience. For more details go to www.mercersmarine.com

Colour: Black/Asphalt

13-4241J.....	Med	599.00
13-4242J.....	Lg	599.00
13-4243J.....	XL.....	599.00
13-4244J.....	.2X.....	599.00
13-4245J.....	.3X.....	639.00



Kompound Jacket (INSULATED)

We engineered the Kompound with visions of riding fully pinned on the trails, then getting deep into backcountry powder. The 3-in-1 construction provides a waterproof GORE-TEX shell and puffy insulated liner, all wearable separately or together, to fine-tune your gear and conquer the conditions no matter what. For more details go to www.mercersmarine.com

Colour: Black/Grey

13-14526J.....	Med	669.00
13-14527J.....	Lg	669.00
13-14528J.....	XL.....	669.00
13-14529J.....	.2X.....	669.00
13-14530J.....	.3X.....	709.00



Instinct Jacket (INSULATED)

Fully redesigned for the modern crossover rider, the Instinct Jacket dominates wide open trails and backcountry powder. With lightweight integrated insulation, vents to cool you down and more streamlined construction, the Instinct handles on- and off-trail riding with ease. For more details go to www.mercersmarine.com

Colour: Black/Gold

13-11325J.....	Sm	539.00
13-11326J.....	Med	539.00
13-11327J.....	Lg	539.00
13-11328J.....	XL.....	539.00
13-11329J.....	.2X.....	539.00
13-11330J.....	.3X.....	579.00



Lochsa Monosuit (SHELL)

The redesigned Lochsa is engineered to be the most durable, breathable and ventilated one-piece on the snow. Using rider feedback and test results, we've refined the proven chassis for better avy readiness, venting and comfort. Lochsa lets the most aggressive riders push harder with less fatigue, bash through trees with more confidence and stay more avalanche-ready than ever before. See full details online at www.mercersmarine.com

Colour: Black/Asphalt

13-4192J.....Sm	1479.00
13-4193J.....Med	1479.00
13-4194J.....Lg	1479.00
13-4195J.....XL	1479.00
13-4196J.....2X.....	1479.00



Valdez Parka (SHELL)

The redesigned Valdez Jacket is the standard by which all other mountain jackets are measured. It has been the most durable snow jacket in our line, and now features new fabrics that offer greater durability at a lower weight than before. The Valdez maintains legendary durability while adding mobility and the needed ventilation to keep you cool. Through this intelligent design you can blast powder and play in the trees with greater confidence than ever before. For more details go to www.mercersmarine.com

Colour: Black

13-14501J.....Med	799.00
13-14502J.....Lg	799.00
13-14503J.....XL	799.00
13-14504J.....2X.....	799.00
13-14505J.....3X.....	839.00



Togwotee Bib Pants (SHELL)

The redesigned Togwotee Bib is the standard by which all other snowmobile bibs are measured. It has been the most durable snowmobile bib in our line, and now features new fabrics that offer greater durability at a lower weight than before. The Togwotee maintains legendary durability while adding mobility and the needed ventilation to keep you cool. Through this intelligent design you can blast powder and play in the trees with greater confidence than ever before. For more details go to www.mercersmarine.com

Colour: Black

13-14511J.....Med	799.00
13-14512J.....Lg	799.00
13-14513J.....XL	799.00
13-14514J.....2X.....	799.00
13-14515J.....3X.....	839.00



Klim TekVest

Lightest, most breathable Tekvest available. The Tek Vest is designed for snowmobilers looking to protect their torso from debris and steering column impact. Armor does not absorb water. Action-cut for the full range of motion. Built with 4 inches of waist adjustment and will not ride up or tap your helmet. Run it loose for greater comfort and increased airflow. Run it tight for excellent back support. **Order 1 size smaller than jacket.**

13-11201J.....Med	579.00
13-11202J.....Lg	579.00
13-11203J.....XL	579.00
13-11204J.....2X.....	629.00
13-11205J.....3X.....	629.00



Klim Deluxe Suspenders

The redesigned KLIM Deluxe Suspenders are ideal for holding up motorcycle pants at the proper height and are designed to work with all KLIM outerwear. With premium leather and metal construction, the KLIM Deluxe Suspenders are durable for long days in the saddle.

13-12022J.....One Size	89.95
------------------------------	-------



Storm Jacket (SHELL)

We completely re-imagined the Storm with Valdez/Togwotee-inspired durability and a snowboard-style, relaxed fit chassis. The fresh aesthetic adds to all the trusted tech that pulls the Storm together. Carve each new line in style and confidence while staying comfortable and dry. For more details go to www.mercersmarine.com

Colour: Black

13-14100J.....	Med	599.00
13-14101J.....	Lg.....	599.00
13-14102J.....	XL.....	599.00
13-14103J.....	2X.....	599.00
13-14104J.....	3X.....	639.00

Tomahawk Jacket (SHELL)

The redesigned Tomahawk Jacket is the choice for mountain riders demanding exceptional mobility and ventilation. Low-bulk, streamlined fabrics support your range of motion while ample ventilation keeps you cool as you work up a sweat. Carve each new line in confidence, comfort and style. For more details go to www.mercersmarine.com

Colour: Black

13-15485J.....	Med	539.00
13-15486J.....	Lg.....	539.00
13-15487J.....	XL.....	539.00
13-15488J.....	2X.....	539.00
13-15489J.....	3X.....	579.00



Storm Pant (SHELL)

The completely re-imagined the Storm with Valdez/Togwotee-inspired durability and a snowboard-style, relaxed fit chassis. The fresh aesthetic adds to all the trusted tech that pulls the Storm together. Carve each new line in style and confidence while staying comfortable and dry. For more details go to www.mercersmarine.com

Colour: Black

13-14125J.....	Med	599.00
13-14126J.....	Lg.....	599.00
13-14127J.....	XL.....	599.00
13-14128J.....	2X.....	599.00
13-14129J.....	3X.....	639.00

Tomahawk Pant (SHELL)

The new Tomahawk Bib is the choice for riders who demand extreme mobility. Streamlined construction and low bulk materials are highly suited for mountain riders who rip light and fast. Carve each new line in confidence, comfort and style. For more details go to www.mercersmarine.com

Colour: Black

13-14689J.....	Med	539.00
13-14690J.....	Lg.....	539.00
13-14691J.....	XL.....	539.00
13-14692J.....	2X.....	539.00
13-14693J.....	3X.....	579.00





Inferno Jacket (MID-LAYER)

We built the Inferno to be one of our most versatile and comfortable pieces that excels at mid-layer performance as well as being the perfect every-day chill-killer. The perfect balance of warmth and light-weight, it is the mid-layer jacket that you can trust before and after the ride. For more details go to www.mercersmarine.com

13-11101J.....Med	129.95
13-11102J.....Lg	129.95
13-11103J.....XL	129.95
13-11104J.....2X	129.95
13-11105J.....3X	129.95



Inferno Pant (MID-LAYER)

The Inferno Mid-Layer Pant from KLIM is easily the most comfortable snowmobile-specific mid-layer pant on the snow. Designed to be comfortable under your favorite KLIM bibs or riding pants and on top of your favorite base layer. Sleek elastic waist fit and simple heat-embossed logo on the back pocket create zero restriction for all-day comfort and warmth. For more details go to www.mercersmarine.com

13-11111J.....Med	119.95
13-11112J.....Lg	119.95
13-11113J.....XL	119.95
13-11114J.....2X	119.95
13-11115J.....3X	119.95



Aggressor 3.0 Shirt (BASE-LAYER)

The Aggressor series provides the most versatile & comfortable layering system available. When combined with KLIM® mid-layers and outerwear systems, you will conquer any climate on planet Earth. For more details go to www.mercersmarine.com

13-11131J.....Med	99.95
13-11132J.....Lg	99.95
13-11133J.....XL	99.95
13-11134J.....2X	99.95
13-11135J.....3X	99.95



Aggressor 3.0 Pant (BASE-LAYER)

The Aggressor series provides the most versatile & comfortable layering system available. When combined with KLIM® mid-layers and outerwear systems, you will conquer any climate on planet Earth. For more details go to www.mercersmarine.com

13-11141J.....Med	99.95
13-11142J.....Lg	99.95
13-11143J.....XL	99.95
13-11144J.....2X	99.95
13-11145J.....3X	99.95



- Always Open
- Sale & Feature items
- View Catalogue
- Thousands of products
- Updated regularly
- Up to date pricing
- Mobile friendly
- Shop from anywhere at anytime

www.mercersmarine.com



CLOTHING

Klim



Klim

Ladies Vailslide Monosuit (INSULATED)

Engineered from the ground up for the modern crossover rider, the Vailslide women's one-piece is at home carving backcountry powder and flying down groomed trails. With legendary KLIM one-piece functionality, lightweight insulation to cut the chill and adjustable ventilation, the Vailslide is ready to adapt to a wide range of conditions right out of the box. For more details go to www.mercersmarine.com

Colour: Black/Metallic Silver

13-1840JXS939.00
13-1841JSm939.00
13-1842JMed939.00
13-1843JLg939.00
13-1844JXL939.00

Colour: Black/Knockout Pink

13-1856JXS899.00
13-1857JSm899.00
13-1858JMed899.00
13-1859JLg899.00
13-1860JXL899.00

Colour: Black/Asphalt

13-1861JXS899.00
13-1862JSm899.00
13-1863JMed899.00
13-1864JLg899.00
13-1865JXL899.00



CLOTHING

Prices are subject to change. Check our website for up to date prices. www.mercersmarine.com



Ladies Allure Jacket (INSULATED)

Developed for mixed trail and off-trail crossover riding, the women's Allure Jacket is versatile for comfort and performance in changing weather conditions. The insulation offers added warmth on top of a mid layer and base layer, while the GORE-TEX outer shell keeps you dry. Ride further and faster with confidence and style in the Allure Jacket. For more details go to www.mercersmarine.com

Colour: Black/Rose Gold

13-1600JXS539.00
13-1601JSm539.00
13-1602JMed539.00
13-1603JLg539.00
13-1604JXL539.00
13-1605J2X539.00

Colour: Asphalt/Crystal Blue

13-1620JXS539.00
13-1621JSm539.00
13-1622JMed539.00
13-1623JLg539.00
13-1624JXL539.00
13-1625J2X539.00

Ladies Fuse Jacket (INSULATED)

We engineered the Women's Fuse Jacket for riding fully pinned on the trails, then getting deep into backcountry powder. The 3-in-1 construction provides a waterproof GORE-TEX shell and puffy insulated liner, all wearable separately or together, to fine-tune your gear and conquer the conditions no matter what. For more details go to www.mercersmarine.com

Colour: Black/Metallic Silver

13-1776JXS669.00
13-1777JSm669.00
13-1778JMed669.00
13-1779JLg669.00
13-1780JXL669.00



Black



Asphalt

Ladies Allure Pant (INSULATED)

Developed for mixed trail and off-trail crossover riding, the women's Allure Bib is versatile for comfort and performance in changing weather conditions. The insulation offers added warmth on top of a mid layer and base layer, while the GORE-TEX outer shell keeps you dry. Ride further and faster with confidence and style in the Allure Bib. For more details go to www.mercersmarine.com

Colour: Black

13-1660JXS539.00
13-1661JSm539.00
13-1662JMed539.00
13-1663JLg539.00
13-1664JXL539.00
13-1665J2X539.00

Tall Sizes

13-1667JMed (Tall)565.00
13-1668JLg (Tall)565.00
13-1669JXL (Tall)565.00

Short Sizes

13-1671JMed (Short)539.00
13-1672JLg (Short)539.00
13-1673JXL (Short)539.00

Colour: Asphalt

13-1675JXS539.00
13-1676JSm539.00
13-1677JMed539.00
13-1678JLg539.00
13-1679JXL539.00
13-1680J2X539.00

Short Sizes

13-1686JSm (Short)539.00
13-1687JMed (Short)539.00
13-1688JLg (Short)539.00
13-1689JXL (Short)539.00





Ladies Strata Jacket (INSULATED)

The Strata Jacket is the warmest, most versatile and durable women's trail jacket. Using the same premium features from the Keweenaw, we tailored the fit and increased the insulation for women riders. Engineered from rider feedback and extensive testing, it is purpose-built to help you adapt to extreme conditions with 3-in-1 insulation while offering better safety on frozen lakes. Strata keeps you on the gas through all conditions, all season long. For more details go to www.mercersmarine.com

Colour: Black/Metallic Silver

13-1800JXS669.00
13-1801JSm669.00
13-1802JMed669.00
13-1803JLg669.00
13-1804JXL669.00
13-1805J2X669.00

Colour: Asphalt/Pink

13-1807JXS669.00
13-1808JSm669.00
13-1809JMed669.00
13-1810JLg669.00
13-1811JXL669.00
13-1812J2X669.00

Ladies Strata Pant (INSULATED)

The Strata Bibs the warmest, most versatile and durable women's trail bib. Using the same premium features from the Keweenaw, we tailored the fit and increased the insulation for women riders. Engineered from rider feedback and extensive testing, it is purpose-built to help you adapt to extreme conditions while offering better safety on frozen lakes. Strata keeps you on the gas through all conditions, all season long. For more details go to www.mercersmarine.com

Colour: Black

13-1830JXS669.00
13-1831JSm669.00
13-1832JMed669.00
13-1833JLg669.00
13-1834JXL669.00
13-1835J2X669.00



Floatation



Ladies Flare Jacket (INSULATED)

In pursuit of enhanced winter safety, we've engineered the women's Flare Jacket to offer floatation assistance, protection and comfort in the extreme conditions trail riders face. This is the first women's float assist GORE-TEX jacket in the world and it doesn't need to be used with floatation bibs to work properly. Ascent Float System (AFS) is a flexible, breathable closed cell foam that we integrated in specially mapped channels that offer floatation benefits without compromising mobility and comfort. AFS foam doesn't absorb water and provides significant insulating properties for warmth on top of the standard insulation. The Flare Jacket is a comprehensive trail snowmobile jacket for riders looking to maximize every winter riding experience. For more details go to www.mercersmarine.com

Colour: Black

13-1980JXS599.00
13-1981JSm599.00
13-1982JMed599.00
13-1983JLg599.00
13-1984JXL599.00
13-1985J2X599.00



Ladies Sundance Jacket (MID-LAYER)

The Sundance is one of Klim's most versatile and comfortable pieces that excels at mid layer performance while being the perfect everyday chill-killer. The perfect balance of warmth and light weight, it is the fleece jacket you can trust before and after the ride. For more details go to www.mercersmarine.com

13-12030JXS129.95
13-12031JSm129.95
13-12032JMed129.95
13-12033JLg129.95
13-12034JXL129.95
13-12035J2X129.95



Ladies Solstice 1.0 Shirt (BASELAYER)

Redesigned from the ground up, the Solstice series provides the most versatile & comfortable layering system available. When combined with KLIM mid-layers and outerwear systems, you will conquer any climate on planet Earth. For more details go to www.mercersmarine.com

13-12000JXS64.95
13-12001JSm64.95
13-12002JMed64.95
13-12003JLg64.95
13-12004JXL64.95
13-12005J2X64.95



Ladies Solstice 3.0 Shirt (BASELAYER)

Redesigned from the ground up, the Solstice series provides the most versatile & comfortable layering system available. When combined with KLIM mid-layers and outerwear systems, you will conquer any climate on planet Earth. For more details go to www.mercersmarine.com

13-11985JXS99.95
13-11986JSm99.95
13-11987JMed99.95
13-11988JLg99.95
13-11989JXL99.95
13-11990J2X99.95



Ladies Sundance Pant (MID-LAYER)

The Sundance Pant is your fall-winter-spring casual pant with a straight leg fit and excellent fleece comfort. It has the mid layer performance for winter activities and casual style for lounging around the cabin. For more details go to www.mercersmarine.com

13-12042JXS119.95
13-12043JSm119.95
13-12044JMed119.95
13-12045JLg119.95
13-12046JXL119.95
13-12047J2X119.95



Ladies Solstice 1.0 Pant (BASELAYER)

Redesigned from the ground up, the Solstice series provides the most versatile & comfortable layering system available. When combined with KLIM mid-layers and outerwear systems, you will conquer any climate on planet Earth. For more details go to www.mercersmarine.com

13-12006JXS64.95
13-12007JSm64.95
13-12008JMed64.95
13-12009JLg64.95
13-12010JXL64.95
13-12011J2X64.95



Ladies Solstice 3.0 Pant (BASELAYER)

Redesigned from the ground up, the Solstice series provides the most versatile & comfortable layering system available. When combined with KLIM mid-layers and outerwear systems, you will conquer any climate on planet Earth. For more details go to www.mercersmarine.com

13-11992JXS99.95
13-11993JSm99.95
13-11994JMed99.95
13-11995JLg99.95
13-11996JXL99.95
13-11997J2X99.95





Klim



Mens Klutch GTX BOA Boot (800 grams)
 We built the Klutch GTX BOA® boot for riders facing both high speed trails and backcountry powder, with a key focus on warmth. The outsole is highly durable and more comfortable for walking, and the BOA® lacing system ensures precise fit, meaning it's natural for all-day riding. For more details go to www.mercersmarine.com

14-2962J	8	14-2966J	12
14-2963J	9	14-2967J	13
14-2964J	10	14-2968J	14
14-2965J	11		

Mens Klutch BOA Boots \$469.00



Klim



Mens Adrenaline GTX Boot (600 grams)
 The Adrenaline GTX® Boot sets the standard for technical snowmobile footwear. For the Adrenaline's 3rd generation, perfecting and improving upon a near-perfect formula was our goal. Adrenaline provides a dry, comfortable, and supportive riding experience across a wide range of conditions without impeding freedom of movement. For more details go to www.mercersmarine.com

14-3035J	7	14-3039J	11
14-3036J	8	14-3040J	12
14-3037J	9	14-3041J	13
14-3038J	10	14-3042J	14

Mens Adrenaline GTX Boots \$399.00



Klim



Mens Adrenaline Pro S GTX Boot (600 grams)
 The Adrenaline GTX® Boot sets the standard for technical snowmobile footwear. Improving and tweaking the Adrenaline BOA® near-perfect formula was our goal. The Adrenaline provides a dry, comfortable, and supportive riding experience across a wide range of conditions without impeding freedom of movement. For more details go to www.mercersmarine.com

14-3108J	7	14-3112J	11
14-3109J	8	14-3113J	12
14-3110J	9	14-3114J	13
14-3111J	10	14-3115J	14

Mens Adrenaline BOA GTX Boots \$539.00



Klim

Klim Crew Socks
 Coolmax Polyester, Polyamide Nylon, Lycra Blend.
 Reinforced toe, heel & sole.

13-905J	(7 - 9)	24.95
13-906J	(10 - 12)	24.95
13-907J	(13 - 15)	24.95



Klim



Ladies Aurora GTX BOA Boot (800 grams)
 Fully redesigned Aurora GTX BOA® boot for riders facing both high speed trails and backcountry powder, with increased insulation to achieve greater warmth. The outsole is highly durable and designed for walking comfort, and the BOA® lacing system ensures precise fit. For more details go to www.mercersmarine.com

14-3022J	6	14-3025J	9
14-3023J	7	14-3026J	10
14-3024J	8	14-3027J	11

Ladies Aurora GTX BOA Boots \$469.00



Klim



Ladies Aurora GTX Boot (800 grams)
 We fully redesigned the Aurora GTX boot for riders facing anything from high speed trails to deep powder, with increased insulation to achieve greater warmth. The outsole is both highly durable and more comfortable for walking, meaning it's ready to go for all-day riding. For more details go to www.mercersmarine.com

14-3016J	6	14-3019J	9
14-3017J	7	14-3020J	10
14-3018J	8	14-3021J	11

Ladies Aurora GTX Boots \$399.00



Klim

Klim Vented Socks
 Engineered for maximum ventilation and moisture transmission, the KLIM Vented Sock is the perfect choice for the hottest rides or for riders who want minimum bulk and maximum moisture removal.

13-909J	(7 - 9)	29.95
13-910J	(10 - 12)	29.95
13-911J	(13 - 15)	29.95





Klim Elite Glove

The Elite is Klim's most durable glove featuring GORE-TEX® + GORE GRIP technology and 3M™ THINSULATE™ Platinum Insulation. The Elite Glove offers the ultimate "broke-in" fit for riders who demand superior grip control without compromising warmth, protection or features. If you're looking for the ultimate "no-compromise" KLIM® glove, this is it.

13-10850J.....	Sm	339.00
13-10851J.....	Med	339.00
13-10852J.....	Lg.....	339.00
13-10853J.....	XL.....	339.00
13-10854J.....	2X.....	339.00
13-10855J.....	3X.....	339.00



Heated

Klim Resistor Heated Glove

Take your cold weather adventures to new "lows" with the Resistor HTD Gauntlet Glove and it's intuitive 3-level heating system. The heating filaments are durable while long lasting lithium-ion batteries ensure consistent heating for your hands and fingers. The high heat mode runs for 10 minutes and automatically switches to medium heat to preserve batteries and avoid overheating your hands. The heating element covers your backhand and fingertips, providing full hand heat when used with heated grips on a snowmobile.

13-10940J.....	Sm	399.00
13-10941J.....	Med	399.00
13-10942J.....	Lg.....	399.00
13-10943J.....	XL.....	399.00
13-10944J.....	2X.....	399.00



Heated

Klim Tundra Heated Gauntlet Glove

Take the legendary warmth of the Tundra split-finger gloves, add our 3-level heating system and you get some of the warmest, most comfortable gloves ever to fight the cold. This design uses a 1-3 split with your index finger free from the other three, providing better control and feel on the handlebars while providing excellent warmth. The heating filaments are durable and long lasting, powered by lithium-polymer batteries to ensure consistent warmth. The heating element covers your backhand and wraps the fingertips, providing full hand heat when used with heated grips on a snowmobile.

13-10946J.....	Med	389.00
13-10947J.....	Lg.....	389.00
13-10948J.....	XL.....	389.00
13-10949J.....	2X.....	389.00
13-10950J.....	3X.....	389.00



Klim Fusion Glove

As the most fully insulated glove in the KLIM lineup and redesigned with outseam construction for maximum comfort, the Fusion incorporates GORE-TEX protection with dual chamber insulation technology for adjustable insulation. With 200 grams 3M™ Thinsulate™ Insulation on the top of hand and 60 grams in an internal divider worn on top or below the hand, the Fusion adapts to every condition.

13-11160J.....	Sm	189.95
13-11161J.....	Med	189.95
13-11162J.....	Lg.....	189.95
13-11163J.....	XL.....	189.95
13-11164J.....	2X.....	189.95
13-11165J.....	3X.....	189.95



Klim Togwotee Glove

The Togwotee Glove offers premium GORE-TEX® waterproof/breathable performance in a leather-palm glove. The removable fleece liner adds additional warmth without bulk, interacting flawlessly with your machine's grips and controls. Designed from the ground up to be fully compatible with KLIM® Glove Liners.

13-10863J.....	Sm	189.95
13-10864J.....	Med	189.95
13-10865J.....	Lg.....	189.95
13-10866J.....	XL.....	189.95
13-10867J.....	2X.....	189.95
13-10868J.....	3X.....	189.95



Klim Klimate Glove

Built for the thrill of wide open trails, we engineered the Klimate gauntlet glove to fight the cold and keep you in control of your sled. Durability and grip are as important as warmth when you face frigid temperatures and biting wind.

13-11170J.....	Sm	119.95
13-11171J.....	Med	119.95
13-11172J.....	Lg.....	119.95
13-11173J.....	XL.....	119.95
13-11174J.....	2X.....	119.95
13-11175J.....	3X.....	119.95





Klim Blaze Gauntlet Glove

The Blaze Gauntlet Glove is built for the thrill of winding trails and high speeds. We engineered the Blaze to keep your hands warm and dry and in harsh winter conditions. Durability with leather construction and grip from articulated fingers and low-bulk construction keep you in control of your sled.

13-10869J.....Sm	169.95
13-10870J.....Med	169.95
13-10871J.....Lg	169.95
13-10872J.....XL	169.95
13-10873J.....2X	169.95
13-10874J.....3X	169.95



Klim Tundra Split Finger Claw Mitt

As part of the Tundra collection, the Tundra Split Finger glove is the ultimate in warmth and technology on the snow. The Tundra is warmest glove design to date and offers dual chamber functionality so you don't give up tactile control of your bars, brakes and throttle. The lobster claw (split finger) design is a perfect compromise between a mitten (superior warmth) and 4 finger glove design (superior tactile control).

13-10856J.....Sm	189.95
13-10857J.....Med	189.95
13-10858J.....Lg	189.95
13-10859J.....XL	189.95
13-10860J.....2X	189.95
13-10861J.....3X	189.95



Klim Climate Shorty Glove

Joining the insulated glove series this year, the Climate Short Glove offers the same premium feel and durability as the Climate Glove, but in a short cuff design. Built with full GORE-TEX® performance, warming comfort of 3M™ THINSULATE™ and tactile grip at an affordable price. Engineered with 200 grams insulation securely on the back-of-hand and fingers, 100 grams on palm and with an ultra-tacky and durable palm material, it will perform in a wide range of riding conditions.

13-11261J.....Sm	99.95
13-11262J.....Med	99.95
13-11263J.....Lg	99.95
13-11264J.....XL	99.95
13-11265J.....2X	99.95
13-11266J.....3X	99.95

Klim



Klim Inversion Pro Glove

Wanting a little more warmth in your Inversion Glove without sacrificing grip, breathability and comfort? Look no further than the Inversion Insulated Glove from KLIM®. This glove combines the original Inversion's 100% WINDSTOPPER® shell with 60 Grams 3M™ THINSULATE™ Platinum insulation on the top-of-hand for just enough warmth. A slip-on cuff makes riding in the Inversion Insulated quick and easy.

13-10934J.....Med	99.95
13-10935J.....Lg	99.95
13-10936J.....XL	99.95
13-10937J.....2X	99.95
13-10938J.....3X	99.95



Klim Caribou Mitt

Winter riding is unpredictable. Prepare for the unknown with the KLIM® Caribou Mitten. Fingers can get cold and in extreme cases, even be frostbitten. Designed to create a method of re-warming cold fingers and abate frostbite. Keep in your kit for emergencies, for when the weather gets bitterly cold or for an extremely comfortable and warm everyday winter glove. Add a KLIM® Glove Liner to the mix and you have an unbeatable combination for the ultimate hand warmth on the snow. Mittens are also compatible with hand warmers.

13-11208J.....Sm	149.95
13-11209J.....Med	149.95
13-11210J.....Lg	149.95
13-11211J.....XL	149.95
13-11212J.....2X	149.95
13-11213J.....3X	149.95



Klim Glove Liner 2.0

The KLIM Glove Liner 2.0 features Polartec PowerStretch material that insulates through loft properties while also dispersing moisture across the 4-way stretch fabric. Users experience added warmth in this direct replacement for stock fleece glove liners. Includes e-touch fingertip function allowing use of capacitive touch screens while being worn.

13-10919J.....Med	24.95
13-10920J.....Lg	24.95
13-10921J.....XL	24.95
13-10922J.....2X	24.95
13-10923J.....3X	24.95



Klim Glove Liner 3.0

Complete WINDSTOPPER protection adds maximum warmth inside your KLIM gloves while increasing outside-the-glove benefits thanks to its windproof properties, silicone grip and e-touch pads on fingertips. Replace existing fleece liners or simply upsize any non-insulated KLIM glove and enjoy the benefits.

13-10924J.....Med	39.95
13-10925J.....Lg	39.95
13-10926J.....XL	39.95
13-10927J.....2X	39.95
13-10928J.....3X	39.95

CLOTHING



Ladies Klim Allure Glove

Built specifically for female hands in search of maximum comfort, the Allure Glove incorporates GORE-TEX protection with dual chamber insulation technology for adjustable insulation (one position maximizing warmth, the other maximizing grip). If you're looking for the women-specific glove that does it all, this is it.

13-11154JXS189.95
13-11155JSm189.95
13-11156JMed189.95
13-11157JLg189.95
13-11158JXL189.95
13-11159J2X189.95



Ladies Klim Ember Gauntlet Glove

We took the functionality of our epic Klimate gloves and built them for women riders, with added backhand insulation and a true women-specific fit. For the Ember Gauntlet, durability and grip are as important as warmth when you face frigid temperatures and biting wind.

13-11275JXS119.95
13-11276JSm119.95
13-11277JMed119.95
13-11278JLg119.95
13-11279JXL119.95
13-11280J2X119.95



Ladies Klim Allure Mitt

Winter riding is unpredictable. Prepare for the unknown with the KLIM® Allure Mitten. Fingers can get cold and in extreme cases, even be frostbitten. Designed to create a method of re-warming cold fingers and abate frostbite. Keep in your kit for emergencies, for when the weather gets bitterly cold or for an extremely comfortable and warm everyday winter glove. Add a KLIM® Glove Liner to the mix and you have an unbeatable combination for the ultimate hand warmth on the snow. Mittens are also compatible with hand warmers.

Black

13-11215JXS149.95
13-11216JSm149.95
13-11217JMed149.95
13-11218JLg149.95
13-11219JXL149.95
13-11220J2X149.95



Ladies Klim Radiant Glove

The Radiate Gauntlet Glove for women is built for the thrill of winding trails and high speeds. We engineered the Radiate to keep your hands warm and dry and in harsh winter conditions. Durability with leather construction and grip from articulated fingers and lowbulk construction keep you in control of your sled.

13-11290JXS169.95
13-11291JSm169.95
13-11292JMed169.95
13-11293JLg169.95
13-11294JXL169.95
13-11295J2X169.95



Ladies 3.0 Solstice Socks

13-896JSm44.95
13-897JMed44.95
13-898JLg44.95



- Always Open
- Sale & Feature Items
- View Catalogue
- Thousands of products
- Updated Regularly
- Up to date Pricing
- Mobile Friendly
- Shop from anywhere at anytime



Glacier Balaclava

Our most technical head sock for the aggressive rider who encounters the harshest conditions. Featuring an over-the-collar design, the Glacier Balaclava is the perfect blend of extreme weather protection and active riding functionality.

13-11178J79.95



Klim Balaclava

The KLIM Balaclava is a long-standing staple in our line of winter headwear, offering a moisture-wicking head and a windproof neck for cold weather protection. The redesigned KLIM Balaclava has improved fit with longer torso extensions and more comfortable seams.

13-11180JBlack.....44.95

13-11184JKnockout Pink.....44.95



Arctic Balaclava

Specifically designed for the coldest riding conditions on Earth, the Arctic Balaclava features a massive feature list fit for the most extreme climates. From the base, the Arctic Balaclava bring a massive ultra-wide skirt to ensure it stays put. Add in full WINDSTOPPER frontal attack with KLIM's variable fleece backer thicknesses around eyes, full neoprene nose piece/breath deflector, lycra stretch back, conformed neck fit, and super stretchy fleece over the head.

13-11181J84.95



Covert Balaclava

The Covert Balaclava offers a blend of weather protection and breathability for taking the chill away from your neck and forehead while allowing heat to escape during physical activity. Redesigned with more comfortable seam placement and a more effective mouthpiece breath area.

13-11182J64.95



Shadow Balaclava

This simple but effective balaclava uses super-soft stretch fleece and DRI-RELEASE wool, which allows the shadow balaclava to be extremely comfortable while maintaining wind protection and warmth.

13-11183J39.95



Rogue Balaclava

Minimal design using WINDSTOPPER and COOLMAX fabrics allows the Rogue Balaclava to be extremely comfortable still offering the functional benefits of technical fabrics. WINDSTOPPER over-the-collar design stops cold air and weather from entering.

13-11187J54.95



Klim Neck Warmer

The Neck Warmer offers soft, comfortable wind-resistant protection against winter chills. With breathable 4-way stretch material that wicks moisture, the Neck Warmer is a great addition to your gear bag or to stash in your glove box for extra cold days.

13-11179JAsphalt.....34.95

13-11195JBlack34.95

13-11196JPink34.95



Inversion Neck Warmer

The Inversion Neck Warmer offers soft comfortable windproof protection. Gore-Tex windstopper. Stretch materials. Fleece inside for warmth. One size fits all.

13-11197J44.95



Klim F3 carbon Helmet ECE

KLIM's F3 helmet is a most-valuable riding partner and features key upgrades in its third generation. Composite shell construction means the F3 is strong and lightweight in a functional, comfortable design. Structure Mapped Composite construction, a new more aerodynamic and durable visor, a complete comfort liner system and intelligent ventilation make the F3 Helmet highly functional.

Black/Asphalt

13-810J.....Med	439.00
13-811J.....Lg.....	439.00
13-812J.....XL.....	439.00
13-813J.....2X.....	439.00
13-814J.....3X.....	439.00

White/Monument Grey

13-815J.....Med	439.00
13-816J.....Lg.....	439.00
13-817J.....XL.....	439.00
13-818J.....2X.....	439.00
13-819J.....3X.....	439.00



Klim Inversion Beanie

Built for off-sled performance in chilly and windy conditions, the Inversion Beanie offers lightweight weather protection for your head and ears.

13-12112J.....Sm/Med	39.95
13-12113J.....Lg/XL	39.95



Klim Swerve Beanie

Reversible beanie. 100% acrylic.

13-11235J.....Black.....	44.95
--------------------------	-------



- Always Open
- Sale & Feature items
- View Catalogue
- Thousands of products
- Updated regularly
- Up to date pricing
- Mobile friendly
- Shop from anywhere at anytime

www.mercersmarine.com



Also find us on



Klim Edge Goggles

The Edge Goggle delivers maximum field of view, undistorted optical perfection and tireless fog resistance. This frameless design creates massive FOV, rewarding you with increased awareness and reduced fatigue. By injection molding the cylindrical, dual-pane lens we also achieve virtually perfect optical clarity. The multi-density frame comfortably seals out the elements and OTG-compatible frame cutouts accommodate your glasses if needed. The locking magnetic quick-release mechanism is intuitive and secure. The bottom line is the Edge Goggle is the sleekest, most functional snow goggle you can buy. For more details go to www.mercersmarine.com



13-2974JBlack.....199.95



13-2973JBlack Polarized.....239.95



13-2976JAsphalt.....199.95

Klim Viper Snow Goggles

The KLIM VIPER/VIPER PRO redefines the riding experience on the snow. The VIPER is engineered to provide the best optical clarity, vision, field of view (F.O.V.) and fit experience. Ventilation and moisture management systems aggressively combat fogging. Integrating a super-thin frame design, the Viper is compatible with a wide range of open-face helmets. For more details go to www.mercersmarine.com



13-2979JChili Pepper.....89.95



13-2984JRaid Black/Yellow.....89.95

Klim Viper Pro Goggles

The KLIM VIPER/VIPER PRO redefines the riding experience on the snow. The VIPER is engineered to provide the best optical clarity, vision, field of view (F.O.V.) and fit experience. Ventilation and moisture management systems aggressively combat fogging. Integrating a super-thin frame design, the Viper is compatible with a wide range of open-face helmets. For more details go to www.mercersmarine.com



13-3307JBlack/Yellow.....119.95



13-3308JBlack/hlVLS.....159.95

Klim Oculus Goggles

The KLIM® Oculus Goggle is designed with one purpose in mind: to give you the best possible vision on the snow. This was accomplished by addressing the three main pain points of all goggles: changing light conditions, fogging and field of vision. The Oculus system with KLIM® Slide-Lock™ technology allows you to quickly and easily change lenses in the field to deal with changing light conditions - essentially it's like having [up to] three goggles with you in a very compact package. The Oculus is engineered with the latest anti-fogging technologies. For more details go to www.mercersmarine.com



13-3313JFade Black.....229.95



13-3314JRisk Red.....229.95



13-3316JElectric Blue.....254.95





Krew Pak

25L. The Krew Pak is the largest capacity riding backpack in KLIM's lineup designed specifically for backcountry excursions. Its pocket layout is ready for quick access to multi-day's worth of supplies and tools. KLIM's innovative removable tool pouch, hydration pouch, avalanche probe storage, shovel storage zones and deluxe padded shoulder straps top the feature list. For more details go to www.mercersmarine.com
7" Deep x 12" Wide x 21.5" Tall
20-216J.....Black Ops..... 259.00



Gray



Black Ops



Black/Knockout Pink



Klim Drift Gear Bag

A more basic version of the Team Gear Bag at a lower price. Pack all your gear with this simple yet durable branded gear bag. 16" x 16" x 36". For more details go to www.mercersmarine.com
20-362JBlack/Silver.....169.95
20-363JBlack/HiVis169.95
20-364JBlack/Pink.....169.95



**Shop or Browse
Online 24/7
at
[mercersmarine.com](http://www.mercersmarine.com)**

Nac Pak

13L. The proven Nac Pak is redesigned for bigger days of riding with enhanced ergonomics to keep you going longer. With the perfect combination of cargo capacity, accessory carrying capacity, quick access and intelligent tool storage, the Nac Pak is the bag riders continue to rely on. The redesigned Nac Pak carries your essentials for a full day outdoors or even a textbook and a small laptop for class. For more details go to www.mercersmarine.com
20-059J.....Gray..... 169.95
20-058J.....Black Ops.....169.95
20-061J.....Black/Knockout Pink.....169.95





Team Gear Bag

We built the Team Gear Bag so you can carry everything you need and more to and from the trailhead. The upgraded bag adds roller capacity as well as a waterproof tarp when you want to protect the contents from moisture. Built to take abuse ride after ride heavy duty materials and full of functionality specific to powersports users. Fill it up, if you dare. For more details go to www.mercersmarine.com

- 16" Deep x 36" Wide x 16" Tall
- 20-220JBlack Carbon.....259.00
- 20-365J.....Black/Rose Gold259.00
- 20-367JRed.....259.00



Klim Duffle

The KLIM deluxe Duffle masters high-mobility storage. Its large main compartment is perfect for weekend civilian clothes duty. Rounding out the functionality is dedicated shoe capacity and safe storage for electronics and documents as well as expandable side panel with adjustable buckle straps perfect for stuffing and securing jackets and other bulky items. 24" x 10" x 12". For more details go to www.mercersmarine.com

- 20-218J..... 119.95



Wolverine Carry-On Bag

Packing intense cargo capacity into a carry-on sized rolling bag, the redesigned Wolverine will deliver KLIM's gear-bag toughness and style wherever it rolls. High-function travel features include an EVA molded base with integrated corner armor, plentiful internal and external pocket choices, lightweight sturdy extendable pull handle and YKK® heavy duty zippers throughout. 22" x 14" x 9". For more details go to www.mercersmarine.com

- 20-060J..... 269.00



Deflect Handlebar Muffs

Engineered to provide hand warmth and wind protection on your trail ride in the most extreme snowmobiling conditions. Built specifically to perform better than all the alternatives, the Deflect allows for the use of a less bulky glove while maintaining protection from biting cold temperatures.

- 20-366J89.95



Kodiak Bag

The Kodiak Bag offers maximum cargo capacity and an intelligent compartmentalized design. From the outside-in, the Kodiak's structural stoutness and weight-distributing design will easily contain all the gear you could ever possibly need. Independent boot, helmet and goggle compartments, cavernous cargo bays and numerous smaller stash and zippered pockets combine to create the ultimate full-size rolling gear bag. For more details go to www.mercersmarine.com

- 36" x 18" x 18"
- 20-219J..... 459.00



Klim Helmet Bag

The perfect accessory helmet bag designed to protect your helmet investment from damage. Constructed with tough nylon materials. Includes a soft fleece-lined interior, carry handles and embroidered logos.

- 13-12114J..... 64.95



K Corp Short Sleeve Tee

Colour: Black/Yellow

13-12116J.....Sm	39.95
13-12117J.....Med	39.95
13-12118J.....Lg.....	39.95
13-12119J.....XL.....	39.95
13-12120J.....2X.....	39.95

Colour: Grey

13-12121J.....Sm	39.95
13-12122J.....Med	39.95
13-12123J.....Lg.....	39.95
13-12124J.....XL.....	39.95
13-12125J.....2X.....	39.95



K Corp Long Sleeve Tee

Colour: Black

13-12200J.....Sm	49.95
13-12201J.....Med	49.95
13-12202J.....Lg.....	49.95
13-12203J.....XL.....	49.95
13-12204J.....2X.....	49.95
13-12205J.....3X.....	49.95



Stealth Hat Flex Fit

Colour: Black

13-12054J.....Sm/Med	39.95
13-12055J.....Lg/XL	39.95

Colour: Grey

13-12092J.....Sm/Med	39.95
13-12093J.....Lg/XL	39.95



K Corp Hat

Colour: Black/Grey

13-10986J.....Sm/Med	39.95
13-10988J.....Lg/XL	39.95

Colour: Black/Yellow

13-10989J.....Sm/Med	39.95
13-10987J.....Lg/XL	39.95



Muffler Hat

13-12090J.....Sm/Med	59.95
13-12091J.....Lg/XL	59.95



Klim Back Country Shovel

Packing a serious punch to the face of backcountry survival situations, the KLIM Backcountry Shovel System comes complete with a quick-access saw blade and massive extendable handle for maximum reach and leverage for both the shovel and saw. The oversize grip handle and wide shovel blade ensure you can move maximum snow with the most efficiency while the sleek, easy-to-carry design keeps all your cutting and digging tools as close as possible. All aluminum construction for lightweight strength.

13-11186J.....	99.95
----------------	-------





2023-24 **EP**



Allied Monosuit

Get as rowdy as you want with the 509 Allied Insulated Monosuit—the ultimate in all-over warmth. It's fully insulated and fully seam-taped with STECH™ waterproof/breathable 10k/10k fabric and burly Cordura® 300D polyester. Three sets of vents—inseam, outseam, and underarm—quickly release excess heat. Includes pockets for everything, a helmet-compatible hood, plus Cordura® reinforced cuffs to fight off running board attacks. See full details online at www.mercersmarine.com

Colour: Stealth

13-5450JMed	829.00
13-5451JLg	829.00
13-5452JXL	829.00
13-5453J2X	859.00

Colour: Black Ops

13-5456JMed	829.00
13-5457JLg	829.00
13-5458JXL	829.00
13-5459J2X	859.00



R4 Ignite Helmet (Heated Visor)

Our innovative new 509 Delta R4 Ignite Helmet sets the new standard for modular flip-up face shield performance with Ignite dual pane heating technology for clear, ice- and fog-free vision in sub-zero conditions. The face shield is oversized for maximum field of view and flips up instantly with the push of a glove-friendly button. Built for maximum warmth and convenience, the helmet's long list of features includes climate control venting and the glove-friendly Fidlock® magnetic strap buckle. For more details go to www.mercersmarine.com

Colour: Black Ops

13-5520JSm	569.00
13-5521JMed	569.00
13-5522JLg	569.00
13-5523JXL	569.00
13-5524J2X	569.00



R3 Delta Ignite Helmet (Heated Visor)

Giving you the ability to switch between three configurations, dual sport, full face, and open face. The 509 Delta R3L Ignite Snowmobile Helmet is the ultimate in multi-use protection. Featuring a fog-blocking heated ITO dual-pane electric shield with weatherproof Shield Lock, plus internal flip-down sun visor, and removable features like a breathbox, chin curtain, liner, and cheek pads, this helmet has it all. DOT/ECE dual safety certified with dual density EPS for maximum impact resistance. Featuring three configuration options: Dual sport, full face, open face. The R3 2.0 has you covered for all types of snowmobiling and all weather conditions. Featuring a fog blocking heated ITO dual pane electric shield, internal flip-down sun visor, removable breath box & chin curtain this helmet has it all. The R3 2.0 is a DOT/ECE dual safety certified helmet featuring a dual-density EPS for maximum impact resistance. The internal liner and cheek pads are removable and washable. For more details go to www.mercersmarine.com

Colour: Black Ops

13-5584JXS	469.00
13-5585JSm	469.00
13-5586JMed	469.00
13-5587JLg	469.00
13-5588JXL	469.00
13-5589J2X	469.00



HEATED

Delta V Carbon Fiber Ignite Helmet (Heated Visor)

For long rides in the cold, the 509 Delta V Carbon Ignite Helmet has you covered. Built from hand-laid carbon for lightweight, durable protection, the secret ingredient here is the heated visor. With a heated visor keeping your shield fog-free, and Venturi Vents that pull out moist air while keeping cold air out, this helmet is ready for long days behind the bars. For more details go to www.mercersmarine.com

Colour: Black Legacy

13-5670J.....	Sm	769.00
13-5671J.....	Med	769.00
13-5672J.....	Lg.....	769.00
13-5673J.....	XL.....	769.00
13-5674J.....	2X.....	769.00
13-5675J.....	3X.....	789.00



HEATED

Delta V Ignite Helmet - (Heated Visor)

For high speeds, frigid temps, and long trails, this helmet is built with dual EPS for durable protection, a luxurious liner, and with our secret ingredient: the IGNITE heated visor. With a 12-volt power input compatible with our 10-hour power Ignite system and Venturi Venting you will have a fog-free view without letting cold in, this helmet is ready for the longest days in the harshest conditions on trail. For more details go to www.mercersmarine.com

Colour: Black Ops

13-5676J.....	Sm	599.00
13-5677J.....	Med	599.00
13-5678J.....	Lg.....	599.00
13-5679J.....	XL.....	599.00
13-5680J.....	2X.....	599.00
13-5681J.....	3X.....	619.00



Black Ops



Legacy



HiVis/Camo



Stormchaser



Racing Red



Orange

Tactical Helmet

The 509 Tactical Helmet is born from a desire to offer industry-leading protection at an affordable price. The absolute best value out there, it goes beyond the basics with a lightweight precise fit, durable polycarbonate outer shell, and revolutionary features like neck brace compatibility. A removable cold weather breathbox and adjustable ventilation adapt to any weather. And like our highest-end helmets, it pairs perfectly with 509 goggles for a seamless fit that maximizes performance. For more details go to www.mercersmarine.com

Colour: Black Ops

13-5535J.....	Sm	279.00
13-5536J.....	Med	279.00
13-5537J.....	Lg.....	279.00
13-5538J.....	XL.....	279.00
13-5539J.....	2X.....	279.00
13-5540J.....	3X.....	289.00

Colour: HiVis/Camo

13-5541J.....	Sm	279.00
13-5542J.....	Med	279.00
13-5543J.....	Lg.....	279.00
13-5544J.....	XL.....	279.00
13-5545J.....	2X.....	279.00

Colour: Racing Red

13-5547J.....	Sm	279.00
13-5548J.....	Med	279.00
13-5549J.....	Lg.....	279.00
13-5550J.....	XL.....	279.00
13-5551J.....	2X.....	279.00

Colour: Legacy

13-5661J.....	Sm	279.00
13-5662J.....	Med	279.00
13-5663J.....	Lg.....	279.00
13-5664J.....	XL.....	279.00
13-5665J.....	2X.....	279.00

Colour: Stormchaser

13-5559J.....	Sm	279.00
13-5560J.....	Med	279.00
13-5561J.....	Lg.....	279.00
13-5562J.....	XL.....	279.00
13-5563J.....	2X.....	279.00

Colour: Orange

13-5553J.....	Sm	279.00
13-5554J.....	Med	279.00
13-5555J.....	Lg.....	279.00
13-5556J.....	XL.....	279.00
13-5557J.....	2X.....	279.00

509 Kingpin Goggles

Affordable and premium: two words that haven't existed together in goggles... until now. The 509 Kingpin Goggle puts performance within reach by combining a quick-change lens system along with high-end anti-fog and anti-scratch dual pane lens technology. To change the lens, simply rotate the left and right mounts 90-degrees. It's that easy. Like all our goggles, the Kingpin pairs perfectly with 509 helmets for a seamless fit that optimizes performance and comfort. For more details go to www.mercersmarine.com



Colour: Black/Yellow
13-5600J 114.95



Colour: Nightvision
13-5601J 114.95



Colour: Black Ops
13-5606J 189.95



Colour: Black/Fire
13-5603J 134.95



Colour: Racing Red
13-5604J 129.95



Colour: Pink/Rose
13-5607J 164.95



Colour: Whiteout
13-5599J 149.95



Kingpin "Over The Glasses" Goggles

The XL version of the 509 Kingpin Goggle features 20% more face foam for maximum warmth and coverage in extremely cold conditions. High-performance, yet affordable, the Kingpin offers our quick-change lens system along with premium anti-fog and anti-scratch dual pane lens technology. To change the lens, simply rotate the left and right mounts 90-degrees. It's that easy. Pair the 509 Kingpin XL Goggle with a 509 helmet for optimal fit, comfort, and performance.

Night Vision
13-5610J 129.95



Ripper Youth Goggles

Featuring the same innovation and attention to detail as our adult styles, the 509 Ripper Youth Goggle doesn't skimp on style or performance so kids can ride hard all day. Kids aren't exactly easy on their gear, so we gave these goggles a durable dual pane lens with premium anti-fog and anti-scratch coatings. The extra-grippy adjustable strap keeps the goggle securely in place, and the fit pairs perfectly with the 509 Youth Altitude Helmet.

13-5614J Black Ops 69.95
13-5615J Cyan/Navy 69.95



HEATED



Kingpin Ignite Goggles (Heated)

Fog doesn't stand a chance with our bestselling 509 Kingpin Ignite Goggle featuring heated lens technology derived from the same science used in military aircraft windshields. Simply push a button and the lightweight, strap-mounted rechargeable lithium-ion power pack quickly heats the entire inner lens surface to 104°F. The system features a 2-minute auto-interval mode or 'always on' mode, along with a continuous runtime rating of up to 5 hours at max temp for all-day clarity.

13-5622J Nightvision 299.00





Range Glove

The coldest days call for the 509 Range Gloves. A top grain goat leather palm combines with STECH™ waterproof/breathable performance for rugged protection in the harshest conditions. Our heaviest weight 3M™ Thinsulate™ insulation is profiled throughout the palm to maintain maximum dexterity on the throttle. An extended length gauntlet cuff with our Speed Cinch and Shear Lock closure makes it easy to lock in warmth around your wrist. For more details go to www.mercersmarine.com

13-5481J.....Med	199.95
13-5482J.....Lg.....	199.95
13-5483J.....XL.....	199.95
13-5484J.....2X.....	199.95
13-5485J.....3X.....	199.95



Back Country Glove

We went all-out when developing the 509 Backcountry Gloves to be better fitting, more durable, and more comfortable than the competition. Built for long days and aggressive riding, these gloves combine rugged stretch softshell fabric and a top grain goat leather palm with a waterproof/breathable membrane and strategically placed 3M™ Thinsulate™ insulation. The extra-long gauntlet cuff and speed cinch creates a snow-proof seal around your wrists. For more details go to www.mercersmarine.com

13-5491J.....Med	164.95
13-5492J.....Lg.....	164.95
13-5493J.....XL.....	164.95
13-5494J.....2X.....	164.95
13-5495J.....3X.....	164.95



Duke Trigger Fingers Mitts

For the coldest days on the sled, pack along the 509 Duke Trigger Finger Mitt. Super warm thanks to Thinsulate™ insulation on the back of the hand and the palm, combined with a waterproof lining, these mitts get their biggest benefit from the trigger finger, which adds dexterity for reaching the brake when you need it. For more details go to www.mercersmarine.com

13-5467J.....Med	179.95
13-5468J.....Lg.....	179.95
13-5469J.....XL.....	179.95
13-5470J.....2X.....	179.95
13-5471J.....3X.....	179.95

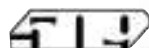

Freeride Gloves

Coming in hot with a full tech overhaul, the 509 Freeride Gloves have been redesigned for a superior fit, have a new velcro closure and sled-specific, pre-curved fingers. Warmth from 70g back and 40g palm Thinsulate insulation, a waterproof/breathable Hipora membrane lining, and top grain goat leather help make these the go-to gloves for riders who explore on and off the trail. For more details go to www.mercersmarine.com

13-5472J.....Med	139.95
13-5473J.....Lg.....	139.95
13-5474J.....XL.....	139.95
13-5475J.....2X.....	139.95
13-5476J.....3X.....	139.95



509 Reversible Beanie

Get twice the style with the 509 Reversible Beanie. With different colors on both sides, simply flip it inside out for a brand-new look. Form-fitting skullcap style, plus 100% acrylic fibers for quick-drying, wool-like warmth and long-lasting comfort.

13-5509J	32.99
----------------	-------



509 Pro Balaclava

Give yourself a little extra breathing room with the laid-back look of the 509 Oversized Beanie. Around town or up in the mountains, it looks good and feels even better with the soft, wool-like warmth and quick-drying comfort of 100% acrylic fibers.

Stealth	
13-5510J.....Lg/XL	39.95
Raspberry Mint	
13-5513J.....Sm/Med	39.95
13-5514J.....Lg/XL	39.95



MENS EDCO 2 PIECE SUIT

Model 2075

Jacket: Seam sealed. Polar collar. Adjustable velcro cuffs. Inside windguard. Inside pocket. Front zipper pockets. Sleeve pocket. Action back. Reflective insert. Adjustable bottom cord. Inner Lycra cuffs.

Pants: Seam sealed. Complete side zippers. Inside polar on upper back, seat and knee. Adjustable suspenders. Leg patch pocket. Back elastic. Double knee. Cordura patch on seat and knee. Inside snow cuffs. Reflective tape.

Black		
11-886MSm449.95
11-887MMed449.95
11-888MLg449.95
11-889MXL449.95
11-890M2X495.50
11-891M3X495.50
11-892M4X520.50
11-893M5X520.50

Black/Blue		
11-894MSm449.95
11-895MMed449.95
11-896MLg449.95
11-897MXL449.95
11-898M2X495.50
11-899M3X495.50



EDCO POLAR NECK WARMER

Lightweight and comfortable.

12-4691P(5004)6.95



DELUXE POLAR NECK WARMER

Lightweight and comfortable.

12-4692P(6003)12.95



LADIES EDCO 2 PIECE SUIT

Model 2175

Jacket: Seam sealed. Polar collar. Adjustable velcro cuffs. Inside windguard. Inside pocket. Front zipper pockets. Sleeve pocket. Action back. Reflective insert. Adjustable botom cord. Inner Lycra cuffs. Detachable zip-off hood.

Pants: Seam sealed. Complete side zippers. Inside polar patch on seat and knee. Adjustable suspenders. Leg patch pocket. Back elastic. Double knee. Cordura patch on seat and knee. Inside snow cuffs. Reflective tape.

Black		
11-902MSm449.95
11-903MMed449.95
11-904MLg449.95
11-905MXL449.95
11-906M2X495.50
11-907M3X495.50
11-908M4X520.50

Black/Fuchsia		
11-910MSm449.95
11-911MMed449.95
11-912MLg449.95
11-913MXL449.95
11-914M2X495.50
11-915M3X495.50
11-916M4X520.50



EDCO BALACLAVA

Lightweight Model

12-4698P(5098)8.95

Heavyweight. Polartech Model

Body hugging 4-way stretch. Highly breathable wind resistant. Machine washable.

12-4697PAdults (5013)17.95

12-4699PYouths (5213)15.95





Ladies Dropseat Feature



EDCO DURAPANT

Shell:420 Denier/Cordura. Lining:Body 8 oz polyfill and nylon.Polar patch fleece insert on seat and knee.
Features: Complete side zipper. Seam sealed seat. Fabric suspender. Suspender buckle. Wide back elastic. Snow cuff. Double knee. Leg patch pocket.Cordura on knee and seat. Reflective tape. 2 way front zipper.

Mens	
12-4804M.....S.....	145.95
12-4805M.....M.....	145.95
12-4806M.....L.....	145.95
12-4807M.....XL.....	145.95
12-4808M.....2XL.....	159.95
12-4809M.....3XL.....	159.95
12-4810M.....4XL.....	168.95
12-4811M.....5XL.....	168.95

Ladies	
12-4812M.....S.....	145.95
12-4813M.....M.....	145.95
12-4814M.....L.....	145.95
12-4815M.....XL.....	145.95
12-4816M.....2XL.....	159.95
12-4817M.....3XL.....	159.95
12-4818M.....4XL.....	168.95

MENS KAMIK "1 PC" SUIT

Dual venting technology. Pocket vents for breathability and function. Reflective striping on front and back. Concealed front zipper. Leg zip to knee. Storm cuff inside. Removable hood. Rated -50°C.

Black	
11-604M.....Sm.....	229.95
11-605M.....M.....	229.95
11-606M.....L.....	229.95
11-607M.....XL.....	229.95
11-608M.....2XL.....	252.95



EDCO SNOWMOBILE PANT

420 Denier nylon. Double knee patch. Side zippers to hip. Adjustable suspenders. Seam sealed. Elastic stir-up.

Mens	
12-660M.....S.....	96.95
12-661M.....M.....	96.95
12-662M.....L.....	96.95
12-663M.....XL.....	96.95
12-664M.....2XL.....	106.50
12-665M.....3XL.....	106.50
12-666M.....4XL.....	111.95
12-673M.....5XL.....	111.95

Ladies	
12-667M.....S.....	96.95
12-668M.....M.....	96.95
12-669M.....L.....	96.95
12-670M.....XL.....	96.95
12-671M.....2XL.....	106.50
12-672M.....3XL.....	106.50

find us on our social media pages

See what's happening, sales, promotions, news & much more.



KIDS



KIDS



KIDS EDCO ONE PIECE SNOWSUITS

Seam sealed. Polar collar. Knit cuffs. Elastic waist. Side zippers to knee. Cordura knee patches. Inside storm cuffs. Front zipper pockets. Detachable hood. Reflective piping. (Smaller size ladies sometimes purchase sizes 16 and 18 in Kids sizes)

**Black/Red
Childrens**

11-260M	2	165.95
11-261M	4	165.95
11-262M	5	165.95
11-263M	6	165.95
11-264M	6X	165.95

Youth

11-265M	7	181.95
11-266M	8	181.95
11-267M	10	181.95
11-268M	12	181.95
11-269M	14	181.95

11-270M	16	199.95
11-271M	18	199.95

**Black/Fuchsia
Childrens**

11-273M	3	165.95
11-272M	2	165.95
11-274M	4	165.95
11-275M	5	165.95
11-276M	6	165.95
11-277M	6X	165.95

Youth

11-278M	7	181.95
11-279M	8	181.95
11-280M	10	181.95
11-281M	12	181.95
11-282M	14	181.95

11-283M	16	199.95
11-284M	18	199.95

KIDS EDCO SNOWMOBILE PANT

420 Denier nylon. Double knees. Full leg zipper. Adjustable suspenders.

**Black
Childrens**

11-461M	2	68.95
11-462M	3	68.95
11-463M	4	68.95
11-464M	5	68.95
11-465M	6	68.95
11-466M	6X	68.95

Youth

11-467M	7	75.50
11-468M	8	75.50
11-469M	10	75.50
11-470M	12	75.50
11-471M	14	75.50

11-472M	16	82.95
11-473M	18	82.95



KIDS EDCO BALACLAVA

Power stretch lycra.

12-4699P	Sm	15.95
----------	----	-------



YOUTH SNOWMOBILE MITTS MODEL 54-61307

Deerskin leather. Reinforced palm and thumb. Decorative stitching on back. Nylon strap with velcro "Thermolite" lining. Color: Black.

YOUTH'S

12-4224P	Sm	89.95
12-4225P	Med	89.95
12-4226P	Lg	89.95



Zeus Open Face Classic Helmet

Open faced classic design. Removable visor. ABS material. Certification: ECE, DOT, NBR.

13-5750JXS	69.95
13-5751JSm	69.95
13-5752JMed	69.95
13-5753JLg	69.95
13-5754JXL	69.95
13-5755J2X	69.95



Zeus Open Face Vintage Helmet

One front vent and two rear vents. Detachable visor. Moisture wicking, removable, breathable, anti-odor, anti-allergenic liner. Durable UV400 retractable sun shield. ABS material. Certification: ECE, DOT, NBR, CNS.

13-5760JXS	109.95
13-5761JSm	109.95
13-5762JMed	109.95
13-5763JLg	109.95
13-5764JXL	109.95
13-5765J2X	109.95



Zeus Motorcross Helmet

Fits most goggles. Wide vision field design. Moisture wicking, removable, breathable, anti-odor, anti-allergenic liner. Lightweight. Removable visor. ABS material. Certification: ECE, DOT, NBR.

13-5770JXS	109.95
13-5771JSm	109.95
13-5772JMed	109.95
13-5773JLg	109.95
13-5774JXL	109.95
13-5775J2X	109.95



GKS SNOWMOBILE GLOVES 50-GKS-702

Goatskin leather. Heatlocker system.

12-5419PSm	49.95
12-5420PMed	49.95
12-5421PLg	49.95
12-5422PXL	49.95



GKS SNOWMOBILE GLOVES 50-61303-DS

Deerskin leather. Strap on back. Removable polar liner "Thermolite" lining. Color: Black.

12-6069PSm	99.95
12-6070PMed	99.95
12-6071PLg	99.95
12-6072PXL	99.95



BATTERY HEATED GLOVES

Misty Mountain Battery Heated Gloves features a waterproof outer to keep hands dry and a brushed fleece lining and Thinsulate® insulation to keep them warm. The touch screen compatible thumb and index fingertip allows you to operate your mobile devices without taking off your gloves. The elastic drawstring cuff closure ensures a secure fit. Uses 3 "AA" batteries (not included)

12-803MMed	39.50
12-804MLg	39.50
12-805MXL	39.50



MEN'S DEERSKIN GLOVES

Deerskin leather glove, with a nylon cuff and back of hand, and a flannel and Thinsulate lining. It has an adjustable strap at the wrist and its anti-snow system helps prevent snow infiltration in the long cuff.

12-6173PSm	69.95
12-6174PMed	69.95
12-6175PLg	69.95
12-6176PXL	69.95
12-6177P2X	69.95



HOT PADS

Non-toxic, non-polluting, non-flammable. Odourless and easy to use. Provides heat for 8 hours. 2 x 30g pads per pack.

20-116PHands	1.75/pk
20-117PFeet	1.75/pk



SNOWMOBILE MITT MODEL 50-61305-DS

Black deerskin grain leather. Reinforced palm. Removable polar liner with "Thermolite". Leather strap. New anti-snow system with elastic closures plus barrel lock. Super warmth!

Men's		
12-4241PSm129.95
12-4242PMed129.95
12-4243PLg129.95
12-4244PXL129.95
Ladies (50-61305-DS-K)		
12-4245PSm129.95
12-4246PMed129.95
12-4247PLg129.95



SNOWMOBILE MITT MODEL 50-GKS-K50-EX

Deerskin leather with nylon back. "Double Thickness" Thermolite. Detachable liner. Really warm mitt.

Men's		
12-6000PSm99.95
12-6001PMed99.95
12-6002PLg99.95
12-6003PXL99.95
Ladies (50-GKS-K50-K-X)		
12-6004PSm99.95
12-6005PMed99.95
12-6006PLg99.95



SNOWMOBILE MITT MODEL 50-61304-DS-NB

Deerskin leather. Removable flannel liner. Thinsulate C100. Anti-snow cuff.

Men's		
12-4237PSm119.95
12-4238PMed119.95
12-4239PLg119.95
12-4240PXL119.95



SNOWMOBILE MITTS MODEL 50-61307-DS

Deerskin leather. Reinforced palm and thumb. Decorative stitching on back. Nylon strap with velcro "Thermolite" lining. Color: Black.

MEN'S		
12-4230PSm99.95
12-4231PMed99.95
12-4232PLg99.95
12-4233PXL99.95
LADIES (50-61307-DS-K)		
12-4234PSm99.95
12-4235PMed99.95
12-4236PLg99.95



SNOWMOBILE MITT MODEL 50-GKS-700

Goatskin leather. Heatlocker system.

Men's		
12-5423PSm59.95
12-5424PMed59.95
12-5425PLg59.95
12-5426PXL59.95



SNOWMOBILE MITT MODEL 50-GKS-600

Goatskin leather. Heatlocker system. Detachable finger glove and polar fleece liner. Exceptionally good value!

Unisex sizing		
12-6089PSm74.95
12-6090PMed74.95
12-6091PLg74.95
12-6092PXL74.95



MEN'S DEERSKIN MITTS

Deerskin leather mitt, with a nylon cuff and back of hand, and a flannel and Thinsulate lining. It has an adjustable strap at the wrist and its anti-snow system helps prevent snow infiltration in the long cuff.

12-6178PSm72.95
12-6179PMed72.95
12-6180PLg72.95
12-6181PXL72.95
12-6182P2X72.95



LADIES MITT MODEL 67-808-C-DS

Beautiful soft deerskin leather with Thinsulate lining. Attached flannel "finger glove" inside. Very comfortable.

Black		
12-5349PSm64.95
12-5350PMed64.95
12-5351PLg64.95
12-5339PXL64.95



BATTERY HEATED MITTS

Misty Mountain Battery Heated Mitts feature a waterproof outer with a leatherette palm, brushed fleece lining, and Thinsulate insulation for warmth. Other features include a removable battery pack with on/off switch, a thumb back with soft lens-wiper fabric, a hook and loop strap adjustment at the wrist, and an elastic drawstring cuff closure. Uses 3 "AA" batteries (not included)

12-800M	Med	39.50
12-801M	Lg	39.50
12-802M	XL	39.50



MENS DEERSKIN LEATHER CAMO GLOVES

Polyester/Polyurethane backhand. Flannel lining. Thinsulate C40 insulation. Adjustment cord.

12-6164P	Med	69.95
12-6165P	Lg	69.95
12-6166P	XL	69.95
12-6167P	2X	69.95



LAMBSKIN LEATHER GLOVES

Wing thumb. Reinforced palm. Heatlocker insulation.

Men's (Model 67-932)

12-4277P	Sm / Black	30.95
12-4278P	Med / Black	30.95
12-4279P	Lg / Black	30.95
12-4280P	XL / Black	30.95
12-4285P	2X / Black	30.95

Ladies (Model 67-932-C)

12-4281P	Sm / Black	30.95
12-4282P	Med / Black	30.95
12-4283P	Lg / Black	30.95
12-4284P	XL / Black	30.95



MERCER'S



MENS DEERSKIN LEATHER CAMO MITTS

Polyester/Polyurethane backhand. Flannel lining. Thinsulate C100 insulation. Adjustment cord.

12-6169P	Med	72.95
12-6170P	Lg	72.95
12-6171P	XL	72.95
12-6172P	2X	72.95



MEN'S DRESS GLOVES

Soft Deerskin leather. Back wrist strap with snap. Lined.

Black

12-2499P	Sm	69.95
12-2500P	Med	69.95
12-2501P	Lg	69.95
12-2502P	XL	69.95



www.mercersmarine.com

- Always Open
- Sale & Feature Items
- View Catalogue
- Thousands of products
- Updated Regularly

- Up to date Pricing
- Mobile Friendly
- Shop from anywhere at anytime

find us on   



Footwear



A NEW STANDARD OF COMFORT, SAFETY AND DURABILITY IN FOOTWEAR



"Purofort" polyurethane boots have to be worn to be appreciated! Totally different from rubber or PVC boots, polyurethane (PU) boots provide "All Day Comfort"! Their unique microfoam polyurethane compound makes Purofort boots warmer, lighter and longer wearing (up to 3 times longer). Flexible in extreme low temperatures....Try them once and you'll see why they are Europe's favorite footwear

Kneeboots



PUROFORT "THERMO+"

CSA grade 1 approved steel toe and midsole. Extra thick sole and uppers give this boot a -50°C rating. Like all Purofort boots, lightweight and softness make this boot a real winner!

Green (D662843-25)

14-6702M6	14-6691M11/12
14-6687M7	14-6692M13
14-6688M8	14-6693M14
14-6689M9	14-6703M15
14-6690M10	

All Sizes \$249.95

PUROFORT THERMO+ FULL SAFETY "OMEGA/EH"

The Purofort Thermo EH (Electric Hazard) is constructed and manufactured so that the outsole can provide a secondary source of electrical hazard protection to the wearer against the hazards of stepping on live electrical circuits, electrically energized conductors, parts or apparatus. Ideal boot for use in cold environments. Safe, thanks to its steel-tipped toe and suitable for conditions down to -58°F (-50°C). **D652033-11**

14-6814M6	14-6819M 11/12
14-6815M7	14-6821M13
14-6816M8	14-6822M14
14-6817M9	14-6823M15
14-6818M10	

All Sizes \$249.95

PUROFORT THERMO+ "EXPLORER" FULL SAFETY WITH VIBRAM SOLE

Flexible Purofort shaft is resistant to chemicals, blood, seawater, oil and fats. Thermal insulation up to -50 C. Flexible and supple even at very low temperatures. Antibacterial treatment. Dunlop red smooth-welded sanitized lining. Premium insole. **The durable Vibram FIRE & ICE outsoles are designed to maintain its performance values in a wide range of temperatures, while the engraved shank provides maximum traction.** Large toe and heel lugs. CSA Grade 1 steel toe, steel plate, ESR - Electric Shock Resistant. **D902033-11**

14-082M6	14-087M 11/12
14-083M7	14-088M13
14-084M8	14-089M14
14-085M9	14-090M15
14-086M10	

All Sizes \$289.95



DUNLOP FIELDPRO THERMO +

Waterproof Purofort (PU) upper. Composite toe and puncture resistant plate. Removable insole. Slip resisting rubber outsole. Resistant to various chemicals and manure. Thermal insulation. Excellent shock absorption. Flexible and lightweight. Cut resistant. Snug-fit construction to eliminate heel slippage.

Black - DLPLHD0-11

14-6471M6	14-6476M 11
14-6472M7	14-6477M 12
14-6473M8	14-6478M13
14-6474M9	14-6479M14
14-6475M10	14-6480M15

All Sizes \$279.95

Green - DLPLKLO-15

14-6483M5	14-6489M 11
14-6484M6	14-6490M12
14-6485M7	14-6491M13
14-6486M8	14-6492M14
14-6487M9	14-6493M15
14-6488M 10	



FOOTWEAR

Prices are subject to change. Check our website for up to date prices. www.mercersmarine.com

PUROFORT+

With features such as an ergonomic design, an exclusive torsion insert, and a non-clogging sole, the Purofort+ will provide you with the all day comfort you've come to expect! Dark green polyurethane boot with black sole. Red torsion insert offers increased stability and enhanced grip. Impact resistant metatarsal protection. Oil resistant outsole. Non-clogging sole. Anti-static, cold insulating, energy absorbing. 35% lighter than conventional boots. Durability - up to 2-3 times longer.



PUROFORT PLUS CSA-1 SAFETY BOOT

Lightweight and extremely comfortable. **D762943-15**

14-6742M3	14-6749M10
14-6743M4	14-6750M11
14-6744M5	14-6751M12
14-6745M6	14-6752M13
14-6746M7	14-6753M14
14-6747M8	14-6754M15
14-6748M9		

All Sizes \$189.95

PUROFORT PLUS SOFT TOE

Lightweight and extremely comfortable. **D760933-15**

14-6728M3	14-6735M10
14-6729M4	14-6736M11
14-6730M5	14-6737M12
14-6731M6	14-6738M13
14-6732M7	14-6739M14
14-6733M8	14-6740M15
14-6734M9	14-6741M16

All Sizes \$139.95

NEW



DUNLOP PUROFORT FIELDPRO FULL SAFETY

Flexible Purofort (PU) upper. Steel toe and puncture-resistant plate. Removable insole. Slip resisting outsole. Resistant to various chemicals and manure. Thermal insulation. Flexible and lightweight. Excellent shock absorption. Antistatic. **Model DLJEK01-8**

14-6643M4	14-6649M10
14-6644M5	14-6650M11
14-6645M6	14-6651M12
14-6646M7	14-6652M13
14-6647M8	14-6653M14
14-6648M9		

All Sizes \$149.95

DUNLOP PIONEER REGULAR TOE BOOTS

PU rated slip resistance. Antibacterial lining. Waterproof and breathable membrane. Thermal insulation down to -40°C. Comfortable and removable insole. Lightweight and flexible. Quick put-on and take off. Moisture absorbing. Hydrophobic and tear resistant.

Model D60A930-18 - Grey

14-6617M5	14-6622M10
14-6618M6	14-6623M11
14-6619M7	14-6624M12
14-6620M8	14-6625M13
14-6621M9	14-6626M14

All Dunlop Pioneer Boots \$249.95

DUNLOP WORK PRO BOOTS

Metal-free toe cap and midsole plate. PU rated slip resistance. Antibacterial lining. Waterproof and breathable membrane. Thermal insulation down to -40°C. Comfortable and removable insole. Lightweight and flexible. Quick put-on and take off. Moisture absorbing. Hydrophobic and tear resistant.

Model D68A930-18 - Grey

14-6605M5	14-6610M10
14-6606M6	14-6611M11
14-6607M7	14-6612M12
14-6608M8	14-6613M13
14-6609M9	14-6614M14

All Dunlop Work Pro Boots \$279.95



DUNLOP PUROFORT FIELDPRO SOFT TOE

Flexible Purofort (PU) upper. Removable insole. Slip resisting outsole. Resistant to various chemicals and manure. Thermal insulation. Flexible and lightweight. Excellent shock absorption. Snug-fit construction to eliminate heel slippage. **Model DFG60E33-5**

14-6456M4	14-6462M10
14-6457M5	14-6463M11
14-6458M6	14-6464M12
14-6459M7	14-6465M13
14-6460M8	14-6466M14
14-6461M9		

All Sizes \$139.95

NEW



GRUNDENS

Kneeboots



TIMBERLAND PRO MUDLINE BOOT

Polyurethane mold waterproof upper. Composite safety toe powered by CarbonShield technology. Direct inject construction. **Internal met guard for impact protection (Black Model-A256Y).** Anti-Fatigue Technology polyurethane footbed for shock absorption and energy return. Non-metallic puncture plate. Contoured Shock-Diffusion Plate. Breathable and moisture-wicking lining with anti-microbial treatment for odour control.

Green Model A2561357

15-8150M7	15-8154M11
15-8151M8	15-8155M12
15-8152M9	15-8156M13
15-8153M10	

Green Mudline Boots \$199.95

Black Model A256Y001

15-8162M7	15-8166M11
15-8163M8	15-8167M12
15-8164M9	15-8168M13
15-8165M10	

Black Mudline Boots \$239.95

GRUNDENS DECK BOSS BOOT

The redesigned Deck-Boss 15-inch Boot features an updated design that sets the new standard for what a fishing boot should be. The Deck-Boss Boot provides all-day comfort, high performance fit and superior traction. Designed to be tough, durable and long lasting, the Deck-Boss Boot is built with a flexible and protective toe cap and an injection molded upper that eliminates delamination and cracking. The Patented "Herkules Grip" compression molded rubber outsole is certified with SRC Slip Resistance, the most stringent level of slip resistance certification; providing best-in-class traction on wet surfaces. The flexible upper folds down when the full 15-inch height is not needed, and a 1-inch groove holds a durable silicone band that keeps pants out of the muck and legs dry.

14-7518M 6	14-7523M11
14-7519M7	14-7524M12
14-7520M8	14-7525M13
14-7521M9	14-7526M14
14-7522M10	14-7527M15

All Grundens Deck Boss Boots \$159.95



DUNLOP ACIFORT HEAVY DUTY BOOTS (SOFT TOE)

Acifort boots are very stable and strong and more durable than conventional PVC boots. They have high resistance to mineral, animal and vegetable oils and fats, manure, blood, acids, disinfectants and various chemicals. This boot is a mixture of PVC and rubber and especially developed for each individual industry. SRA-slip resistant outsoles for different environments.

D440631-15

14-6842M7	14-6847M12
14-6843M8	14-6848M13
14-6844M9	14-6849M14
14-6845M10	14-6850M15
14-6846M11	

All Sizes \$49.95



NEW DECK-BOSS BOOT

FOOTWEAR



BEKINA THERMOLITE "PU" BOOT

Polyurethane construction. Electric shock resistant. Protective non-metallic toe cap and midsole. Extra thick upper and sole. Thermal insulation now good up to -50 C. Lightweight, comfortable, and flexible. Free ergonomic insoles.

Model Z090GG

15-7081M6	15-7086M11
15-7082M7	15-7087M12
15-7083M8	15-7088M13
15-7084M9	15-7089M14
15-7085M10	

All Sizes \$179.95



BEKINA STEPLITE XCI "PU" SAFETY BOOT

Foamed Polyurethane waterproof construction. Thermal insulation good up to -40°C. Non-metallic toe cap and midsole. Enhanced comfort: wider fitting. Anti-bacterial and abrasion-resistant lining. Kick-off spur for quick removal. Aggressive winter anti-clogging soles for added slip resistance. Shock-absorbent heel. **Cut-off line to make shorter boot from 15" to 11.5".**

Lightweight, comfortable, and flexible. Ergonomic, shock-absorbing, washable footbeds. Model XC90BR

15-7092M5	15-7098M11
15-7093M6	15-7099M12
15-7094M7	15-7100M13
15-7095M8	15-7101M14
15-7096M9	15-7102M15
15-7097M10	

All Sizes \$159.95



BEKINA STEPLITE X "PU" SOFT TOE BOOT

Foamed PU waterproof construction with soft toe. Long-lasting, tough-wearing PU remains flexible at -30°C. Enhanced comfort: wider fitting. Anti-bacterial and abrasion-resistant lining. Kick-off spur for quick removal. Anti-clogging sole for added slip resistance. Shock-absorbent heel. Cut-off line to make shorter boot from 15" to 11.5". Lightweight, comfortable, and flexible. Ergonomic, shock-absorbing, washable footbeds. Model X210 (Soft Toe)

15-7043M4	15-7049M10
15-7044M5	15-7050M11
15-7045M6	15-7151M12
15-7046M7	15-7152M13
15-7047M8	15-7153M14
15-7048M9	15-7154M15

All Sizes \$106.95



BEKINA STEPLITE X "PU" SAFETY BOOT

Foamed Polyurethane waterproof construction. Long-lasting, tough-wearing PU remains flexible at -30°C. Non-metallic toe cap and midsole. Wider fitting. Anti-bacterial and abrasion-resistant lining. Kick-off spur for quick removal. Anti-clogging sole for added slip resistance. Shock-absorbent heel. **Cut-off line to make shorter boot from 15" to 11.5".** Lightweight, comfortable, and flexible. Shock-absorbing, washable footbed. Model X290

Green (Safety)

15-7056M5	15-7062M11
15-7057M6	15-7063M12
15-7058M7	15-7064M13
15-7059M8	15-7065M14
15-7060M9	15-7066M15
15-7061M10	

White (Safety)

15-7068M5	15-7074M11
15-7069M6	15-7075M12
15-7070M7	15-7076M13
15-7071M8	15-7077M14
15-7072M9	15-7078M15
15-7073M10	

All Sizes \$129.95



BEKINA REPLACEMENT INSOLES

Shock absorber. Slip-resistant. Fits all models on page.

15-7104M4	15-7110M10
15-7105M5	15-7111M11
15-7106M6	15-7112M12
15-7107M7	15-7113M13
15-7108M8	15-7114M14
15-7109M9	15-7115M15

All Sizes \$10.95/pr



ACTON ALL WEATHER BOOT

Waterproof lightweight PU boot. Composite toe protector. Non-metallic insole. CSA grade 1 and ESR certified. CSA certified internal METATECH metguard. Comfortable removable insole. Natural 4GRIP 4ICE rubber outsole. 90° heel angle. ABSORB+ heel absorbing impact. Oil, acid, manure and fat resistant. Easy care product. Antimicrobial treatment. **Model A4155-18**

14-1627M 6	14-1632M11
14-1628M 7	14-1633M12
14-1629M 8	14-1634M13
14-1630M 9	14-1635M14
14-1631M10	

All Acton All Weather Boots \$189.95



ACTON BERING BOOT

Waterproof lightweight PU boot. Composite toe protector. Non-metallic insole. CSA grade 1 and ESR certified. CAS certified internal METATECH System Cross. Comfortable removable insole. Resistant self cleaning PU outsole. 90° heel angle. Oil, acid, manure and fat resistant. Easy care product. Antimicrobial treatment. **Model A4154-15**

14-1566M 6	14-1571M11
14-1567M 7	14-1572M12
14-1568M 8	14-1573M13
14-1569M 9	14-1574M14
14-1570M10	

All Acton Bering Boots \$159.95



ACTON ICELANDER 2.0

Natural rubber 4GRIP outsole. Composite toe protector. Antipuncture non metallic plate. CSA grade 1 and ESR certified. CSA certified internal METATECH metguard. Energy absorber heel with an angle of 90°. Waterproof lightweight PU boot. High performance removable 5 layers IFELT liner. Removable Thermo IGL00-EVA insole. Nylon collar with lace adjustment and barrel lock. Heel kick to get out of the boot easily. Antimicrobial treatment. Extremely sturdy design and insulation unique. **Model A3961B-11**

14-1483M7	14-1487M11
14-1484M 8	14-1488M12
14-1485M 9	14-1489M13
14-1486M10	14-1490M14

All Acton Icelander 2.0 Boots \$199.95

ICELANDER 2.0 REPLACEMENT LINERS

14-1491M7	14-1495M11
14-1492M 8	14-1496M12
14-1493M 9	14-1497M13
14-1494M10	14-1498M14

All Acton Icelander 2.0 Liners \$42.95



ACTON ALL TERRAIN BOOT

Waterproof lightweight PU boot. Comfortable removable insole. Composite toe protector. **Non-metallic**, anti-perforation, lightweight, very flexible and non-conductive insole. CSA grade 1 and ESR certified. Resistant PU self cleaning outsole. Oil, acid, manure and fat resistant. Easy care product. Energy absorber heel with an angle of 90 degrees.

Model A4144-11 - Black

14-1468M3	14-1475M10
14-1469M4	14-1476M11
14-1470M5	14-1477M12
14-1471M 6	14-1478M13
14-1472M 7	14-1479M14
14-1473M 8	14-1480M15
14-1474M 9	14-1481M16

Model A4144-15 - White

14-1601M3	14-1608M10
14-1602M4	14-1609M11
14-1603M5	14-1610M12
14-1604M 6	14-1611M13
14-1605M 7	14-1612M14
14-1606M 8	14-1613M15
14-1607M 9	14-1614M16

Acton All Terrain Boots (White) \$126.95

Model A4144-15 - Green

14-1587M3	14-1594M10
14-1588M4	14-1595M11
14-1589M5	14-1596M12
14-1590M 6	14-1597M13
14-1591M 7	14-1598M14
14-1592M 8	14-1599M15
14-1593M 9	14-1600M16

All Terrain Boots (Black & Green) \$126.95





ACTON OCEAN BOOT

Waterproof lightweight PU boot. Breathable lining. Composite toe protector. Metalfree composite puncture-resistant plate. Comfortable removable insole. Natural rubber and PU core outsole. Heel kick to get out of the boot easily. 90° heel angle. Easy to clean

Model A4160-16

14-1642M8	14-1646M12
14-1643M9	14-1647M13
14-1644M10	14-1648M14
14-1645M11	

All Acton Ocean Boots \$119.95



ACTON TRACK 4 X 4 BOOT

Waterproof lightweight PU boot, resistant to oil, acid, manure and animal fat. Breathable lining with antimicrobial treatment. Removable insole made of PU foam for a long-lasting comfort, Slip resistant, self-cleaning and stable PU outsole. 90° heel angle. Easy to care. Model A4193-15

14-1510M 6	14-1516M12
14-1511M 7	14-1517M13
14-1512M8	14-1518M14
14-1513M9	14-1519M15
14-1514M10	14-1520M16
14-1515M11	

All Acton Track 4 x 4 Boots \$119.95



ACTON STORMY BOOT

Waterproof synthetic rubber boot. Nylon collar with barrel lock closure system preventing snow penetration. Removable insulated felt liner. Composite toe protector and steel puncture-resistant plate. Resistant synthetic rubber self-cleaning outsole. Heel kick to get out of the boot easily. 90° heel angle. Easy to care. Large calves space. Model A4191-11

14-1653M 6	14-1658M11
14-1654M 7	14-1659M12
14-1655M8	14-1660M13
14-1656M9	14-1661M14
14-1657M10	

All Acton Stormy Boots \$104.95



ACTON FUNCTION REGULAR TOE BOOT

Very affordable waterproof multipurpose boots. Waterproof PVC boot. Non-compacting outsole. Easy care product. Oil and manure resistant.

Model A4141-11

14-1427M 5	14-1432M10
14-1428M 6	14-1433M11
14-1429M7	14-1434M12
14-1430M8	14-1435M13
14-1431M9	

All Acton Function Reg. Toe Boots \$29.95



ACTON FUNCTION SAFETY BOOT

Waterproof PVC boot. Non-compacting outsole. Easy care product. Steel toe protector. Antipuncture steel plate. CSA grade 1 certified boot. Oil and manure resistant. Model A4142-11

14-1436M 5	14-1441M10
14-1437M 6	14-1442M11
14-1438M7	14-1443M12
14-1439M8	14-1444M13
14-1440M9	

All Acton Function Safety Boots \$49.95



ACTON TACKLE REGULAR TOE BOOT

Waterproof rubber boot combining style and comfort. This product is developed for hunters, fisherman and outdoor enthusiasts. Natural rubber outsole. Comfortable and insulating neoprene lined boot. Waterproof natural rubber shell and upper. EVA outsole. Tight fit for an excellent comfort. Adjustment strap. Heel kick to get out of the boot easily. Easy-to-clean outsole. Model A3992-15

14-1615M 5	14-1620M10
14-1616M 6	14-1621M11
14-1617M7	14-1622M12
14-1618M8	14-1623M13
14-1619M9	14-1624M14

All Acton Tackle Reg. Toe Boots \$126.95



BAFFIN ICEBEAR CSA

Thermal injected, acid and oil resistant "Polyurethane" upper, and Gelflex midsole; Acid and oil resistant outsole. Minus 50 C/58F comfort rating and cold crack tested. "Non-Metallic" safety toe and plate. CSA/ASTM approved. ESR/EH rated.

14-2613M5	14-2619M 11
14-2614M6	14-2620M 12
14-2615M7	14-2621M13
14-2616M8	14-2622M14
14-2617M9	14-2623M15
14-2618M10	

All Sizes \$239.95



BAFFIN ICEBEAR SOFT TOE

Thermal injected, acid and oil resistant "Polyurethane" upper, and Gelflex midsole; Nitrile acid and oil resistant outsole. Minus 50 C/58F comfort rating and cold crack tested. Designed for woodsmen and hunters. Nylon tie-top.

14-2626M5	14-2632M 11
14-2627M6	14-2633M 12
14-2628M7	14-2634M13
14-2629M8	14-2635M14
14-2630M9	14-2636M15
14-2631M10	

All Sizes \$214.95



BAFFIN HERCULES

Polyurethane upper and rubber outsole construction. Flexible upper, Gelflex cushion midsole and abrasion/slip resistant rubber outsole. Proven Hex-Flex outsole design. CSA / ASTM approved aluminum toe and non-metallic plate. CSA / ASTM approved toe and plate with electric shock resistant, electric hazard protection.

14-3181M4	14-3187M10
14-3182M5	14-3188M 11
14-3183M6	14-3189M 12
14-3184M7	14-3190M13
14-3185M8	14-3191M14
14-3186M9	

All Sizes \$199.95



BAFFIN BRUTUS

Polyurethane upper and outsole. 2 stage injection moulding allows for a flexible upper and highly abrasion resistant outsole. Proven self cleaning outsole design. Comfort crafted insole. CSA/ASTM approved toe and plate with static dissipative protection.

14-3193M4	14-3199M10
14-3194M5	14-3200M 11
14-3195M6	14-3201M 12
14-3196M7	14-3202M13
14-3197M8	14-3203M14
14-3198M9	

All Sizes \$136.95



MEN'S BAFFIN ENDURO

15" Premium quality boot with "Gelflex" shock absorbing heel and midsole. Removable molded insole. Comfortable boot!

REGULAR TOE

14-531M7	14-535M11
14-532M8	14-536M12
14-533M9	14-537M13
14-534M10	14-538M14

All Sizes \$69.95

STEEL TOE , STEEL PLATE

14-842M7	14-846M11
14-843M8	14-847M12
14-844M9	14-848M13
14-845M10	14-849M14

All Sizes \$82.95

MEN'S BAFFIN MAXIMUM

15" Premium "light-weight" boot with "Gelflex" shock absorbing heel and midsole. Oarprene oil and acid resistant rubber. Removable insole. Steel toe and plate. Electric shock resistant. CSA / ASTM approved chemical resistant boot.

14-1865M7	14-1869M11
14-1866M8	14-1870M12
14-1867M9	14-1871M13
14-1868M10	14-1872M14

All Sizes \$86.95



VIKING CHAINSAW BOOT

Nylon tie top. CSA approved.

14-1127K.....4	14-1132K.....9
14-1128K.....5	14-1133K.....10
14-1129K.....6	14-1134K.....11
14-1130K.....7	14-1135K.....12
14-1131K.....8	14-1136K.....13

All Sizes \$184.95



MEN'S CONSTRUCTOR

Acid and oil resistant neoprene and leather upper design. Acid and oil resistant stitching, laces and metal free hardware. High visibility reflective strips. Acid and oil resistant rubber Outsole for slip resistance in extreme cold temperatures. Ice Bear outsole design for additional traction in ice and snow. Light weight PU base is cold crack tested to 50,000 flexes at -50C. Light weight Gel-flex mid-sole provides cushioning to reduce fatigue and improve comfort. Improved fit allows for maximum comfort and support. **Metal free safety toe and plate** with Electric shock resistant sole. Baffin -100°C 8 layered inner boot Microcellular waffle foot-bed traps air and moisture. Frost plate foot-bed.

MEN'S DERRICK

Acid and oil resistant neoprene upper. Acid and oil resistant stitching and laces. High visibility reflective strips. Acid and oil resistant rubber Outsole for slip resistance in extreme cold temperatures. Ice Bear outsole design for additional traction in ice and snow. Light weight PU base is cold crack tested to 50,000 flexes at -50C. Light weight Gel-flex mid-sole provides cushioning to reduce fatigue and improve comfort. Improved fit allows for maximum comfort and support. **Metal free safety toe and plate** with Electric shock resistant sole. Baffin -100°C 8 layered inner boot. Microcellular waffle foot-bed traps air and moisture. Frost plate foot-bed. CSA / ASTM / CE approved.

CSA / ASTM / CE approved.

14-2686M5	14-2692M11
14-2687M6	14-2693M12
14-2688M7	14-2694M13
14-2689M8	14-2695M14
14-2690M9	14-2696M15
14-2691M10	

14-2675M5	14-2681M11
14-2676M6	14-2682M12
14-2677M7	14-2683M13
14-2678M8	14-2684M14
14-2679M9	14-2685M15
14-2680M10	

All Sizes \$264.95



MEN'S SAFETY TITAN CSA-1

Full moulded waterproof boot. 1" snow cuff. -100C/148F inner boot system. Micro-cellular waffle foot-bed to trap air and moisture. Aggressive, long wearing, self-cleaning outsole. CSA/ANSI approved.

MEN'S BAFFIN BLAST CAP SAFETY BOOT

Oil and acid resistant Polyurethane base. Oil and acid resistant rubber outsole. Metal free non-detectable safety components and hardware. External metatarsal protection. Hi-Visibility accents for improved safety. CSA / ASTM approved safety toe, plate and metatarsal protection with electric shock and electric hazard protection.

14-5574M7	14-5578M11
14-5575M8	14-5579M12
14-5576M9	14-5580M13
14-5577M10	14-5581M14

14-2717M7	14-2721M11
14-2718M8	14-2722M12
14-2719M9	14-2723M13
14-2720M10	14-2724M14

All Sizes \$199.95

All Sizes \$279.95



MEN'S WORKHORSE

Acid and oil resistant nitrile rubber outsole is self cleaning and slip resistant. Extremely lightweight. Non metallic safety toe and sole protection. CSA / ASTM / CE approved.

14-2540M7	14-2544M11
14-2541M8	14-2545M12
14-2542M9	14-2546M13
14-2543M10	14-2554M14

All Sizes \$264.95



BAFFIN HUNTERS CSA-1 (8564)

Lightweight and flexible TR compound. CSA/ASTM approved. ESR/EH rated. Steel toe and plate. Black upper with green sole.

14-1015M6	14-1020M11
14-1016M7	14-1021M12
14-1017M8	14-1022M13
14-1018M9	14-1029M14
14-1019M10	

All Sizes \$99.95



BAFFIN REFINERY (8574)

Acid and oil resistant oarprene compound. Long wear self cleaning outsole. Steel toe and plate. CSA/ASTM approved. ESR/EH rated.

14-996M6	14-1001M11
14-997M7	14-1002M12
14-998M8	14-1003M13
14-999M9	14-1004M14
14-1000M10	

All Sizes \$104.95





Workboots

TERRA "GANTRY" WORKBOOT

Premium waterproof leather with waterproof Hydroguard membrane. Padded top collar. Dual-purpose top hardware for quick lacing. Moisture-wicking lining with CLEANFEET odour-control treatment. Abrasion-resistant custom "Workie" TECTUFF vamp and heel. Moulded TERRA TPU toe bumper for increased abrasion resistance. Rigid external heel counter for improved lateral stability. 3M Scotchlite reflective detail for high visibility. Cemented high rebound PU midsole. VIBRAM FIRE & ICE outsole for superior traction and performance in high heat & sub-zero temperatures. Premium comfort PU + eTPU JETSTRIDE FOOTBED insole. CSA Grade 1 composite KRYPTOE, composite plate, E.S.R.

Model TB0A4NRQGYX - Grey

15-1613M7	15-1621M11
15-1615M8	15-1623M12
15-1617M9	15-1624M13
15-1619M10	15-1625M14

Model TB0A4NRQBRN - Brown

15-1628M7	15-1636M11
15-1630M8	15-1638M12
15-1632M9	15-1639M13
15-1634M10	15-1640M14

Terra Gantry Boots \$279.95

TERRA "GANTRY" INT-MET WORKBOOT

Premium waterproof leather with waterproof membrane. Padded top collar. Moisture-wicking lining with odour-control treatment. Moulded toe bumper for increased abrasion resistance. Rigid external heel counter for improved lateral stability. 3M Scotchlite reflective detail for high visibility. XRD Internal MET guard. Cemented high rebound PU midsole. VIBRAM outsole for superior traction and performance in high heat & sub-zero temperatures. Premium comfort insole. CSA Grade 1 nanocomposite safety toe, composite plate, E.S.R.

Model TR0839CBLK - Black

15-1374M7	15-1384M12
15-1376M8	15-1385M13
15-1378M9	15-1386M14
15-1380M10	15-1387M15
15-1382M11	15-1388M16

Terra Gantry INT MET Boots \$309.95



TERRA "PATTON WELLINGTON" WORKBOOT

Premium, full grain, lightly pebbled, waterproof leather upper with waterproof Hydroguard membrane. Cemented, shock absorbing, high rebound PU midsole. High-traction, oil, acid & slip resistant, heavy-duty rubber outsole. Dual-density high rebound EVAJETBOUND FOOTBED insole. CSA Grade 1 aluminum toe, composite plate, E.S.R.

Model TR0A4TCBRRN - Brown

15-1647M7	15-1654M11
15-1648M8	15-1656M12
15-1650M9	15-1657M13
15-1652M10	15-1658M14

Terra Patton Wellington Boots \$209.95

TERRA "CARBINE" WORKBOOT

Premium waterproof leather with waterproof membrane. Mesh top collar. Dual-purpose top speedhooks for quick lacing. Moisture-wicking lining with odour-control treatment. 200 grams of Thinsulate insulation for added warmth. External heel counter for improved lateral stability. Molded toe bumper for increased abrasion resistance. Dual-density high rebound insole. Cemented construction elevates performance and protection with a puncture resistant plate between high rebound PU and industrial grade, slip resistant rubber. CSA Grade 1 composite safety toe, composite plate, E.S.R.

Model TR0A4TCRBRN - Brown

15-1199M7	15-1209M12
15-1201M8	15-1210M13
15-1203M9	15-1211M14
15-1205M10	15-1212M15
15-1207M11	

Model TR0A4TCRBLK - Black

15-1213M7	15-1223M12
15-1215M8	15-1224M13
15-1217M9	15-1225M14
15-1219M10	15-1226M15
15-1221M11	

Terra Carbine Boots \$249.95

FOOTWEAR



TERRA

METAL FREE



NEW

METAL FREE



NEW
TERRA

METAL FREE



TERRA

METAL FREE
 -60°C

TERRA "SENTRY" WORKBOOT

Full-grain waterproof sealed-seam leather upper. Four-row stitched "combat" upper pattern with comfort bellows tongue. Abrasion-resistant TECTUFF leather back strap. Moisture-wicking lining with CLEANFEET odour control treatment. 200g Thinsulate insulation. All-season, slip-resistant heavy-duty TPU outsole. Direct-injected, lightweight, and shock-absorbing PU midsole, with PU toe bumper. Premium comfort PU FOOTBED CSA Grade 1 composite KRYPTOE, composite plate, E.S.R.

Model TR0A4NQ9FWE-Wheat

15-1270M7	15-1278M11
15-1272M8	15-1279M12
15-1274M9	15-1280M13
15-1276M10	15-1281M14

Model TR0A4NQ9GYX-Grey

15-1283M7	15-1291M11
15-1285M8	15-1292M12
15-1287M9	15-1293M13
15-1289M10	15-1294M14

Terra Sentry Boots \$229.95

TERRA "MURPHY" WORKBOOT

Full-grain waterproof leather upper. Pull-on twin gore construction. Moisture-wicking and abrasion-resistant lining. CLEANFEET odour-control treatment. Direct-injected PU midsole. Slip, heat and acid-resistant TPU outsole. Premium comfort dual-density PU FOOTBED® insole. CSA Grade 1 composite toe, composite plate, ESR TERRA FIRMA FLEX® – 100% Metal Free.

Model TR0A4NRFQYX - Grey

15-6509M7	15-6517M11
15-6511M8	15-6518M12
15-6513M9	15-6519M13
15-6515M10	15-6520M14

Model TR0A4NRFBRN - Brown

15-6529M7	15-6537M11
15-6531M8	15-6538M12
15-6533M9	15-6539M13
15-6535M10	15-6540M14

Terra Murphy Boots \$189.95



TERRA

METAL FREE

TERRA "CROSSBOW" WORKBOOT

Direct injected cold formulated PU shell bottom. High traction rubber outsole with diamond cleat design. Full grain waterproof leather upper. Integrated pull tab and 3M reflective piping. Channelled metal free eyelets (Top two locking). Removable 4 layer liner with injected heel glide. Temp, rating -60C/-76F. Moisture capture frost plug. Ergonomic low profile composite toe cap and plate. **Metal Free. Model 915605**

15-1024M7	15-1028M11
15-1025M8	15-1029M12
15-1026M9	15-1030M13
15-1027M10	15-1031M14

Terra Crossbow Boots \$289.95

Replacement Liners for Crossbow

15-1033K7	15-1037K11
15-1034K8	15-1038K12
15-1035K9	15-1039K13
15-1036K10	15-1040K14

All Terra Crossbow Liners \$74.95

TERRA "ARGO" WORKBOOT

Full grain waterproof sealed-seam leather upper. Exclusive pull-on collar ports. Moisture wicking and abrasion resistant aero-lining. 200g Thinsulate insulation and odour control treatment. High traction, slip-resistant rubber outsole. Direct injected, shock absorbing PU midsole and PU toe bumper. Premium dual density PU FOOTBED. CSA Grade 1 composite toe, composite plate, E.S.R. Metal free. **Model 02974B**

15-1411M7	15-1418M11
15-1412M8	15-1419M12
15-1414M9	15-1420M13
15-1416M10	15-1421M14

Terra Argo Boots \$239.95



NEW

TERRA



METAL FREE



NEW

TERRA



METAL FREE

TERRA 8" "PATTON" WORKBOOT

Premium, full grain, lightly pebbled, waterproof leather upper. Moisture-wicking lining with CLEANFEET® odour-control treatment. Moulded TPU toe bumper for increased abrasion resistance. Rigid, TECTUFF™ external heel counter. Cemented, shock absorbing, high rebound PU midsole. High-traction, oil, acid & slip resistant, heavy-duty rubber outsole. Dual-density high rebound EVA JETBOUND™ FOOTBED® insole CSA Grade 1 aluminum toe, composite plate, E.S.R.

Model TR0A4NS5BRN - Brown		Model TR0A4NS5BLK - Black	
15-1076M7	15-1084M11	15-1098M7	15-1106M11
15-1078M8	15-1086M12	15-1100M8	15-1108M12
15-1080M9	15-1087M13	15-1102M9	15-1109M13
15-1082M10	15-1088M14	15-1104M10	15-1110M14

Terra 8" Patton Boots \$189.95



Shop or Browse Online 24/7 at mercersmarine.com



NEW

TERRA



METAL FREE



NEW

TERRA



METAL FREE

TERRA "LITES" WORKSHOE

Ultralight monofilament ripstop upper. PU reinforced heel counter and durable climbing rubber toe protection. Fixed tongue and sock-collar construction. Superflex breathable and moisture-wicking lining. Injected EVA high rebound midsole. Slip-resistant rubber pod outsole. Cored center channel with TPU support plate. Dual-density PU/eTPU JETSTRIDE FOOTBED insole. CSA Grade 1 KRYPTOE, composite plate, ESR;ASTM F2413-18 (ASTM F2413-18). TERRA FIRMA-FLEX – 100% Metal Free. **Model**

Model TR0A4NRBBLG - Black/Grey		Model TR0A4NRBA35 - Black/Lime	
15-1580M7	15-1588M11	15-1600M7	15-1608M11
15-1582M8	15-1589M12	15-1602M8	15-1609M12
15-1584M9	15-1590M13	15-1604M9	15-1610M13
15-1586M10	15-1591M14	15-1606M10	15-1611M14

Terra Lites Workshoe \$169.95



TERRA







METAL FREE

Ladies

TERRA "PACER 2.0" SAFETY SHOE

Breathable microfibre and micro-mesh upper, sewn and punched eyelets. Moisture wicking and abrasion resistant lining. CLEANFEET odour control treatment. Reflective 3M Scotchlite heel and vamp accents. Athletic, high traction industrial rubber outsole. Lightweight shock absorbing EVA midsole with TPU arch shank. Premium single density EVA FOOTBED. CSA Grade 1 composite toe, composite plate. TERRA FIRMA-FLEX® metal free.

Model TR106010BLB - Black/Blue

15-1524M7	15-1531M11
15-1525M8	15-1532M12
15-1527M9	15-1533M13
15-1529M10	15-1534M14

Model TR106021PRX - Black/Purple - Ladies

15-1536M5	15-1542M8
15-1538M6	15-1544M9
15-1540M7	15-1546M10

Terra Pacer 2.0 Safety Shoes \$139.95



CAT 8" DIAGNOSTIC WORKBOOT

Built to withstand the toughest work environments, the Diagnostic 2.0 8" Waterproof Composite Toe Work Boot has the trusted safety toe protection needed to take on any challenge.

Composite toe, Slip-Resistant rubber outsole and Tumbled full grain Waterproof leather upper paired with a breathable membrane and Revive footbed protect from the elements and keep you on the go no matter how long the shift.

Brown Model P725893

14-15256M7	14-15264M11
14-15258M8	14-15265M12
14-15260M9	14-15266M13
14-15262M10	

All CAT Diagnostic Boots \$264.95



CAT 8" EXCAVATOR WORKBOOT

8" workboot. Lightweight, yet highly protective, composite toe and electrical hazard features. And, if your work takes you outside, you won't have to worry about the wet or cold weather conditions as the ExcavatorXL is waterproof and insulated with 200 grams of Thinsulate™. The T1410 outsole is engineered for extreme slip resistance and includes our exclusive SRX outsole compound which exceeds industry standards at reducing the risk of slips and falls in the workplace. This work boot is also powered by ERGO Technology which combines biomechanics, ingenuity, hardened durability and trademark grit to create a shoe that will provide comfort all day long.

Red Brown Model P722757

14-15156M7	14-15165M12
14-15158M8	14-15166M13
14-15160M9	14-15167M14
14-15162M10	14-15168M15
14-15164M11	

All CAT Excavator Boots \$279.95



CAT "CHELSEA AT" WORKBOOT

WP Full Grain Leather. Soft, breathable nylon mesh lining. LEAP Technology footbed for tough comfort. Soft, breathable nylon mesh sock lining with CLEANSPORE NXT pro-biotic odor control. ReVive: Engineered Comfort Technology. Durable rubber outsole + SRX for extreme slip resistance. Cement construction.

Brown Model P725314

14-15219M7	14-15227M11
14-15221M8	14-15229M12
14-15223M9	14-15230M13
14-15225M10	

All CAT Chelsea AT Boots \$199.95



CAT HAULER 8" WORKBOOT

Never worry about staying dry. Part of the new ULTRADUTY collection, the Hauler waterproof work boot is engineered to function in the toughest environments and hardest jobs. The Ergo design philosophy combines extreme comfort and flexibility with maximum durability. Upper: Waterproof Full Grain Leather. Lining: Nylon Mesh. Sock Liner: Nylax & PU Foam. Midsole: Molded PU. Outsole: T1200. Protective Plate: Fabric. Construction: Strobel/Cement. Insulation: 200 gms. Thinsulate™.

Brown Model P717629

14-15001M7	14-15009M11
14-15003M8	14-15010M12
14-15005M9	14-15011M13
14-15007M10	



Black Model P717628

14-15012M7	14-15020M11
14-15014M8	14-15021M12
14-15016M9	14-15022M13
14-15018M10	

All CAT Hauler Boots \$269.95



CAT 6" "EXCAVATOR" WORK BOOT

Upper: Crazy Horse Waterproof Leather keeps feet dry and protected and provides long-term durability. Lining: Soft, breathable nylon mesh sock lining with NXT antibacterial layer to reduce odor. Outersole: SRX Slip-Resistant rubber outsole is abrasion resistant, performs against oil and water and provides best-in-class traction on slippery surfaces. Midsole: Reinvented EASE midsole for lightweight cushioning.

Brown Model P724871

14-15169M7	14-15177M11
14-15171M8	14-15178M12
14-15173M9	14-15179M13
14-15175M10	

All CAT Excavator Boots \$229.95



KODIAK 8" MCKINNEY WORK BOOT

Kodiak 8" waterproof boot with M.U.T. Multi Use Toe. Full grain waterproof leather and waterproof membrane construction. Full bellows leather tongue. Cemented and stitched Rubber M.U.T. Multi Use Toe. Kodiak odour control technology. Comfortzone footbed with OrthoLite comfort foam. Oil & slip resisting, non-marking rubber outsole. CSA and ASTM approved composite toe, composite plate, ESR

Model KD0A4TEPDBX

15-6371M7	15-6381M12
15-6373M8	15-6382M13
15-6375M9	15-6383M14
15-6377M10	15-6384M15
15-6379M11	

All Kodiak McKinney Boots \$239.95



KODIAK QUEST BOUND MID WORK BOOT

Premium, rugged, waterproof fullgrain leather hiker. Breathable, waterproof membrane construction. TPU molded toe guard for added durability. TPU molded heel and eyestay strap offers stability and protection. Kodiak SOS Smell Out Science odour control technology. Comfortzone footbed with OrthoLite comfort foam. Compression molded EVA midsole offers shock absorption. Oil, Heat & Slip resisting Vibram TC4 rubber outsole compound. CSA and ASTM approved composite toe, composite plate, ESR. **Model KD0A4TELA62**

15-6328M7	15-6336M11
15-6330M8	15-6337M12
15-6332M9	15-6338M13
15-6334M10	15-6339M14

All Quest Bound Mid Boots \$209.95



KODIAK WIDEBODY WORK BOOT

Rugged 6" waterproof leather boot with integrated pull tab. Full grain waterproof leather with waterproof membrane construction. Molded rubber toe guard and heel guard provide additional protection. Leather vamp overlay and 3M reflective trim detail. Kodiak SOS Smell Out Science odour control technology. Comfortzone footbed. Oil & slip resisting non-marking rubber outsole. CSA and ASTM approved composite toe, composite plate, ESR/EH Model **KD0A4TGCBRN**

15-6343M8	15-6352M13
15-6345M9	15-6353M14
15-6347M10	15-6354M15
15-6349M11	15-6356M16
15-6351M12	

All Kodiak Widebody Boots \$249.95

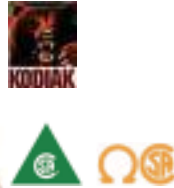

KODIAK 6" CRUSADE WORK BOOT

ROCKFIBRE metal free composite toe and composite puncture resistant plate keep feet safe. Full grain waterproof leather upper with waterproof membrane. 200 gm Thinsulate insulation. KODIAK SOS Smell Out Science system naturally eliminates odour. Full leather bellows tongue. Durable, abrasion resistant toe guard. Removable comfort trainer cored, EVA insole. KODIAK Ultimate SR & oil resistant rubber outsole. 2 sets of laces. CSA approved grade 1, composite toe, composite plate, electric shock resistance (E.S.R.). **Model 305001**

15-6254M7	15-6262M11
15-6256M8	15-6263M12
15-6258M9	15-6264M13
15-6260M10	15-6265M14

All Kodiak Crusade Boots \$169.95

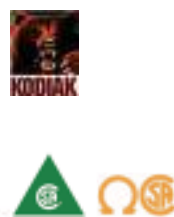

KODIAK 6" TRAKKER WORK BOOT

Waterproof leather upper with waterproof membrane. 200 grams of Thinsulate™ Insulation. Slip Resisting and oil resistant rubber outsole. Abrasion resistant rubber toe and heel guard. Breathable nylon mesh lining. Removable EVA molded FOOTBED. Full bellows padded tongue. Lightweight compression molded EVA midsole. Nylon padded collar and quarter. Rockfibre® META L FREE Technology. CSA approved Grade 1. **Model 302113**

15-6196M7	15-6204M11
15-6198M8	15-6205M12
15-6200M9	15-6206M13
15-6202M10	15-6207M14

All Kodiak Trakker Boots \$179.95

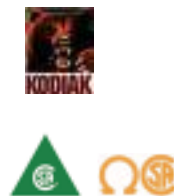

KODIAK QUEST BOUND CHELSEA WORK BOOT

Premium, rugged, waterproof full grain leather double gore Chelsea boot. TPU molded toe guard for added durability. Abrasion resistant heel guard overlay. KODIAK odour control technology. Comfortzone footbed with OrthoLite comfort foam. Compression molded EVA midsole offers shock absorption. METAL FREE. Oil, heat and slip-resistant Vibram TC4+ rubber outsole compound. CSA approved composite toe, composite plate, ESR

Model KD0A4THNBLK

15-6412M7	15-6422M12
15-6414M8	15-6423M13
15-6416M9	15-6424M14
15-6418M10	15-6425M15
15-6420M11	

All Kodiak Quest Bound Chelsea Boots \$199.95

NEW



KODIAK 8" GREB WORK BOOT

Full-grain, lightly pebbled 8" leather work boot. Full leather padded tongue with comfort collar 200 gm Thinsulate insulation Abrasion resistant, moisture wicking Cambrelle lining. Heavy duty polyester pull-tab and lace-keeper. Comfortzone LITE footbed built with Ortholite Hybrid compound. Direct injected polyurethane midsole with integrated injected toe bumper. Slip and oil resistant TPU outsole. CSA approved grade 1 steel toe, composite plate, ESR. **Model KD0A4TH3BRN**

15-6356M7	15-6366M12
15-6358M8	15-6367M13
15-6360M9	15-6368M14
15-6362M10	15-6369M15
15-6364M11	

All Kodiak Greb Boots \$174.95

NEW



KODIAK LADIES JOURNEY WORK BOOT

Waterproof leather upper with waterproof membrane. 200 gm Thinsulate insulation. Full bellows padded tongue. Breathable nylon mesh lining. Molded TPU heel guard and rubber toe guard. Removable PU molded insole. Lightweight compression molded EVA midsole. Kodiak Ultimate SR & oil-resistant rubber outsole compound. CSA approved grade 1, composite toe, composite plate, E.S.R. **Model KD305003DWX**

15-6267M6	15-6273M9
15-6269M7	15-6275M10
15-6271M8	

All Kodiak Ladies Journey Boots \$189.95

NEW



KODIAK LADIES BRALORNE WORK BOOT

Iconic work boot styling gets a refresh, with a heritage-inspired buffalo plaid collar that elevates the look while maximizing the coziness. Fully waterproof with membrane and sealed seams, and lined with Thinsulate™ insulation, this boot is built for overcoming rough conditions while looking your best.

Model KD0A4NM1BRN

15-6303M6	15-6309M9
15-6305M7	15-6311M10
15-6307M8	15-6312M11

All Kodiak Ladies Bralorne Boots \$209.95

NEW



KODIAK LADIES WHITTON CHELSEA WORK BOOT

Kodiak double gore Chelsea boot. Rugged Full grain leather upper. Kodiak SOS Smell Out Science odour control technology. 100% recycled polyester, abrasion resistant lining. Comfortzone LITE footbed built with OrthoLite Hybrid compound. Lightweight, oil and slip resistant Rubberlon outsole, integrated with BLOOM algae blended foam. CSA and ASTM approved steel toe, steel plate, ESR. **Model KD0A4TEXDBX**

15-6388M6	15-6394M9
15-6390M7	15-6396M10
15-6392M8	

All Kodiak Ladies Whitton Boots \$159.95



KODIAK QUEST BOUND LOW WORK SHOE

Premium, rugged, waterproof fullgrain leather hiker. Breathable, waterproof membrane construction. TPU molded toe guard for added durability. Kodiak SOS Smell Out Science odour control technology. Comfortzone footbed with OrthoLite comfort foam. Compression molded EVA midsole offers shock absorption. Oil, Heat & Slip resisting Vibram TC4 rubber outsole compound. CSA and ASTM approved composite toe, composite plate, ESR. **Model KD0A4TF3A66**

15-6314M7	15-6322M11
15-6316M8	15-6323M12
15-6318M9	15-6324M13
15-6320M10	15-6325M14

All Quest Bound Low Work Shoes \$189.95



KODIAK QUEST BOUND 8" WORK BOOT

Premium, rugged, waterproof full grain leather 8" boot. Breathable, waterproof membrane construction. 50% recycled polyester mesh padded tongue and collar textile. TPU molded toe guard for added durability. TPU molded heel and eyestay strap offers stability and protection. KODIAK odour control technology. Comfortzone footbed with OrthoLite comfort foam. Compression molded EVA midsole offers shock absorption. Oil, heat and slip-resistant Vibram TC4+ rubber outsole compound. CSA approved composite toe, composite plate, ESR. **Model KD0A4THHBRN**

15-6400M8	15-6408M12
15-6402M9	15-6409M13
15-6404M10	15-6410M14
15-6406M11	15-6411M15

All Kodiak Quest Boots \$239.95



Red Wing safety boots adhere to the most rigorous industry safety standards regardless of how extreme the conditions. Workers the world over have come to depend on Red Wing boots as the standard in the safety footwear industry.



RED WING 9" WORKBOOT (MODEL 3548)

9" winter safety boot. Composite toe and Plate. ESR rated. 800G Thinsulate. Full grain waterproof leather. Vibram Galactic Fire and Ice outsole. Non-marking. Slip resistant. Puncture resistant. Oil and Gas resistant and excellent chemical resistance.

15-348M8	15-356M12
15-350M9	15-357M13
15-352M10	15-358M14
15-354M11	15-359M15

All Sizes \$379.95



RED WING BRNR XP 8" WORKBOOT (MODEL 3573)

Stay safe and productive in this heavy-duty 8-inch boot with puncture-resistant, electrical hazard and non-metallic safety toe protection. The waterproof leather upper and best-in-class GripTek rubber outsole keep you surefooted in wet conditions, while triple-stitched toe and heel overlays protect high-wear areas. The PU midsole and Quadrex V2 footbed deliver superior all-day comfort.

15-439M8	15-447M12
15-441M9	15-448M13
15-443M10	15-449M14
15-445M11	15-450M15

All Sizes \$389.95



RED WING BRNR XP 8" WORKBOOT (MODEL 3534)

Stay safe and productive in this durable, heavy-duty lace-up boot with electrical hazard, metatarsal and non-metallic safety toe protection. Red Wing waterproofing and CogsmoComfort insulation combine with best-in-class puncture-, slip- and heat-resistance to keep you protected and surefooted in all conditions. Premium Kevlar stitching is fire-retardant up to 800° F, making this style ideal for the foundry.

15-424M8	15-432M12
15-426M9	15-433M13
15-428M10	15-434M14
15-430M11	15-435M15

All Sizes \$409.95



IRISH SETTER WORKBOOT (MODEL 83866)

Go to work in style. Loaded with technologies that deliver out-of-the-box comfort and performance. The TriTek sole, innovative midsole and high-rebound ENERGO material combine to fight fatigue with every step. Waterproof full grain leather. NON-METALLIC toe is lighter weight and shaped to offer more toe room. ARMATEC abrasion-resistant protective covering. Electrical Hazard rating.

15-728M8	15-736M12
15-730M9	15-737M13
15-732M10	15-738M14
15-734M11	

All Sizes \$299.95



RED WING 8" WORKBOOT (MODEL 2414)

This boot delivers big for comfort, durability and protection, making it a favorite among workers in oil and gas, construction and manufacturing industries who push their feet to the limit. The dual-density urethane sole includes a soft, cushioning inner sole layered beneath a tough, puncture- and chemical resistant outer sole. A full-grain, GORE-TEX waterproof leather upper keeps you dry and productive.

15-360M7	15-368M11
15-362M8	15-370M12
15-364M9	15-371M13
15-366M10	15-372M14

All Sizes \$399.95



RED WING 8" WORKBOOT (MODEL 3522)

A lightweight version of the classic work boot with the iconic flat-bottom sole that offers stability and all day comfort. Premium lightweight performance. Unmatched comfort and protection. Non-Metallic Safety Toe or Soft Toe. Waterproof. Puncture Resistant. Electrical Hazard rating.

15-410M8	15-418M12
15-412M9	15-419M13
15-414M10	15-420M14
15-416M11	

All Sizes \$339.95



RED WING 11" WORKBOOT (MODEL 3505)

Mahogany Original leather. Dual density Supersole Welt construction. Swen-Flex insole. Azrec SuperSole 2.0 outsole. Fiberglass shank. Non-Marking. Puncture resistant. Steel toe. Oil/Gas and chemical resistant.

15-332M7	15-342M12
15-334M8	15-343M13
15-336M9	15-344M14
15-338M10	15-345M15
15-340M11	

All Sizes \$349.95



RED WING BOOT BUMPER REPAIR

East to apply. Non-marking. An economical solution to the premature wear of the toe area on footwear. Adhesive included.

15-375MBlack20.95
15-376MBrown20.95



RED WING TUFF TOE

Provides superior toe protection; works on all shoes and boots. Super durable Material. Five minute set up. Cures in 24 hours.

15-378MBlack49.95
15-379MBrown49.95



CAT STREAMLINE 2 SAFETY SHOE

Fast. Athletic. And built for the grind. The Streamline 2.0 is made for game day. With the look and feel of a running shoe, the protection of a composite toe, and breathability from Kurim materials, this shoe is built for the hustle.

- Nylon Mesh/TPU/PU Nubuck
- Soft, breathable nylon mesh lining
- Molded PU foam footbed for underfoot comfort
- Soft, breathable nylon mesh sock lining with pro-biotic odor control
- Durable rubber outsole for traction

Black - Model P725306

14-15206M7	14-15214M11
14-15208M8	14-15216M12
14-15210M9	14-15217M13
14-15212M10	

All CAT Streamline 2 Shoes \$169.95



CAT STREAMLINE 2 SAFETY SHOE

Fast. Athletic. And built for the grind. The Streamline 2.0 is made for game day. With the look and feel of a running shoe and the protection of a composite toe, this shoe is built for the hustle.

- Full Grain Leather
- Soft, breathable nylon mesh lining
- Molded PU foam footbed for underfoot comfort
- Soft, breathable nylon mesh sock lining with pro-biotic odor control.
- Durable rubber outsole for traction

Brown - Model P725307

14-15244M7	14-15252M11
14-15246M8	14-15253M12
14-15248M9	14-15254M13
14-15250M10	

All CAT Streamline 2 Shoes \$159.95



STC LADIES "LADYFIT" WORK SHOE

Synthetic PU and fabric upper. Lightweight and non-conductive composite toe and puncture-resistant plate. Breathable mesh lining with antimicrobial treatment. Removable Instant Comfort insole made of gel, PU and memory foam. PU scuff resistant bumper toe increasing wear protection. Dual density outsole made of natural rubber and comfortable lightweight PU core. Padded tongue and collar allowing extra comfort.

Model S29080

15-2064M6	15-2072M10
15-2066M7	15-2074M11
15-2068M8	15-2075M12
15-2070M9	

All Ladies Ladyfit Shoes \$149.95



STC "BRUCE" WORK SHOE

Waterproof suede upper with H2O Seal sealed seams. Steel toe protector and composite puncture-resistant insole. Breathable and abrasion resistant lining with antimicrobial treatment. Removable Instant Comfort insole made of gel, PU and memory foam. Natural and robust rubber scuff resistant bumper toe increasing wear protection. Dual density Vibram HK-R outsole made of TC4+ natural rubber and comfortable lightweight EVA core. Padded tongue and collar allowing extra comfort. Model S21971

15-2725M7	15-2732M11
15-2726M8	15-2733M12
15-2728M9	15-2734M13
15-2730M10	15-2735M14

All STC Bruce Shoes \$189.95



STC "ACROBAT" WORKBOOT

8" boot with new bruzer sole. Single density polyurethane with TPU. Nubuc buffalo leather. Suede tongue. 200g Thinsulate insulation. Removable molded footbed. gunmetal hexagon eyelets. CSA/ASTM toe and plate, ESR. Model 21987

15-1895M7	15-1902M11
15-1896M8	15-1903M12
15-1898M9	15-1904M13
15-1900M10	15-1905M14

All STC Acrobat Boots \$209.95



Side Zipper on opposite side



STC "BLITZ" WORKBOOT

8" norwegian cut with zipper. Foam and Isofix lining. Smooth sylflex leather vamp. Steel toe and plate with a Nitrille rubber sole VIBRAM type, electric shock resistant. Fabrication INJEX Isofix Cambrelle lining with removable cushioned insole. CSA-1 Approved. Model 21990

15-1946M5	15-1953M10
15-1947M6	15-1955M11
15-1948M7	15-1956M12
15-1949M8	15-1957M13
15-1951M9	15-1958M14

All STC Blitz Boots \$274.95



METAL FREE



STC "ALLOY" WORKBOOT

100% Metal Free external metguard boot featuring wide fitting composite toe and Lenzi puncture proof plate. Full grain, water resistant, breathable leather. Cushioning polyurethane midsole with hard wearing, oil & acid resistant, "Vibram" rubber outsole. PU bumper toe for added abrasion resistance. Lighter and more flexible than steel toe footwear. CSA/ASTM toe & plate. Electric Shock Resistant. Model 22007

15-1819M7	15-1827M11
15-1821M8	15-1829M12
15-1823M9	15-1831M13
15-1825M10	15-1832M14

All STC Alloy Boots \$289.95



STC "DAWSON" WORKBOOT

8" work boot. Waterproof nubuck leather upper. Cambrelle lining. Removable Instant Comfort insole. Steel toe protector. Metalfree composite puncture-resistant plate. V4K Vibram TC4+ outsole made of natural rubber. PU scuff resistant toe cap. Padded tongue for added comfort. 90° heel angle. Model 22022

15-2001M7	15-2008M11
15-2002M8	15-2009M12
15-2004M9	15-2010M13
15-2006M10	15-2011M14

All STC Dawson Boots \$229.95



STC "DUNCAN II" WORKBOOT

Waterproof full grain leather upper. Breathable and abrasion resistant lining. 200g Thinsulate insulation. Breathable waterproof Sympatex membrane. Removable Instant Comfort insole. Composite toe protector. Puncture-resistant insole. GW9 Vibram Fire & Ice Goodyear Welt outsole. Padded collar and tongue for added comfort. Natural rubber scuff resistant bumper toe. Model 21999

15-1846M6	15-1854M11
15-1847M7	15-1855M12
15-1848M8	15-1856M13
15-1850M9	15-1857M14
15-1852M10	

All STC Duncan II Boots \$329.95



STC "SHIRE" WORKBOOT

Waterproof ballistic nylon and CHEMTECH upper. Cambrelle lining. 200g Thinsulate insulation. Breathable waterproof Sympatex membrane. Removable Instant Comfort insole. Composite toe protector. Puncture-resistant insole. Dual density GEN6 Vibram outsole made of rubber&PU. PU scuff resistant toe cap. Padded collar and tongue for added comfort. Model 21994

15-1971M5	15-1978M10
15-1972M6	15-1980M11
15-1973M7	15-1981M12
15-1974M8	15-1982M13
15-1976M9	15-1983M14

All STC Shire Boots \$309.95



STC "HARDROCK" WORKBOOT

10" workboot. Waterproof full grain leather upper. Cambrelle lining. Breathable waterproof Sympatex membrane. Internal Metatech 360 metguard protection. Removable Instant Comfort insole. Steel toe protector. Metalfree composite puncture-resistant plate. V4K Vibram TC4+ outsole made of natural rubber. PU scuff resistant toe cap. 90° heel angle. Padded collar and tongue for added comfort. Fire resisatnt NOMEX thread. 200g Thinsulate™ insulation. **Model 22006**

15-1986M6	15-1994M11
15-1987M7	15-1995M12
15-1988M8	15-1996M13
15-1990M9	15-1997M14
15-1992M10	

All STC Hardrock Boots \$374.95



STC "TRAINER EFIT" SAFETY SHOE

Synthetic PU and nylon upper. Composite toe protector and puncture-resistant insole. Breathable mesh lining with antimicrobial treatment. Removable Instant. Comfort insole made of gel, PU and memory foam. PU scuff resistant bumper toe increasing wear protection. Dual density PST outsole made of TC4+ natural rubber and comfortable lightweight EVA core. Padded tongue and collar allowing extra comfort. **Model S29069**

15-2700M7	15-2707M11
15-2701M8	15-2708M12
15-2703M9	15-2709M13
15-2705M10	15-2710M14

All STC Trainer Efit Shoes \$149.95



STC "TRAINER" SAFETY SHOE

Nylon upper. Breathable mesh lining. Removable Instant Comfort insole. Composite toe protector. Metalfree composite puncture-resistant plate. Natural rubber and EVA core outsole. PU scuff resistant toe cap. Padded collar and tongue for added comfort. **Model 29029**

15-1920M7	15-1927M11
15-1921M8	15-1928M12
15-1923M9	15-1929M13
15-1925M10	15-1930M14

All STC Trainer Shoes \$149.95



STC "REBEL" WORKBOOT

8" workboot. Waterproof leather upper with quadruple sealed seams. Composite toe protector and puncture resistant insole. Breathable and abrasion resistant lining with antimicrobial treatment. Waterproof and breathable Drylock II membrane. 200g Thinsulate insulation surrounding the foot. Removable instant Comfort insole made of gel, PU and memory foam. TPU scuff resistant bumper toe increasing wear protection. OUTLAW outsole made of natural rubber. High visibility reflective inserts. Padded tongue and collar allowing extra comfort.

Black Model 29046-11

15-1795M7	15-1802M11
15-1796M8	15-1803M12
15-1798M9	15-1804M13
15-1800M10	15-1805M14



Brown Model 29046-15

15-1807M7	15-1814M11
15-1808M8	15-1815M12
15-1810M9	15-1816M13
15-1812M10	15-1817M14

All STC Rebel Boots \$289.95



STC "TRAINER 6" WORK BOOT

6" work boot. Synthetic PU and nylon upper. Composite toe protector and puncture-resistant insole. Breathable mesh lining with antimicrobial treatment. Removable Instant Comfort insole made of gel, PU and memory foam. PU scuff resistant bumper toe increasing wear protection. Dual density PST outsole made of TC4+ natural rubber and comfortable lightweight EVA core.. Padded tongue and collar allowing extra comfort. **Model S29070**

15-2712M7	15-2719M11
15-2713M8	15-2720M12
15-2715M9	15-2721M13
15-2717M10	15-2722M14

All STC Trainer 6" Boots \$159.95



TIMBERLAND 8" BOONDOCK WORKBOOT

Waterproof Insulated Composite Toe. Premium waterproof leather with waterproof membrane for abrasion resistance and dry feet. Contoured tongue for comfort. Goodyear Welt construction for durable mechanical bond. Vibram rubber toe protector. Thermolite 200g insulation. Rigid external heel cup for lateral stability. Cambrelle lining with Agion antimicrobial treatment for odor control. Fiberglass shank for structural support. Anti-Fatigue Technology with conical geometry in polyurethane midsole to reduce shock and return energy. Rubber outsole: Timberland traction tread design. Abrasion resistant. Non-marking. Ladder Lock outsole radius.

Black Model TB089645001

15-7327M7	15-7334M10.5
15-7328M7.5	15-7335M11
15-7329M8	15-7336M12
15-7330M8.5	15-7337M13
15-7331M9	15-7338M14
15-7332M9.5	15-7339M15
15-7333M10	

Brown Model TB089646214

15-7340M7	15-7347M10.5
15-7341M7.5	15-7348M11
15-7342M8	15-7349M12
15-7343M8.5	15-7350M13
15-7344M9	15-7351M14
15-7345M9.5	15-7352M15
15-7346M10	

Wheat Model TBOA21B7231

15-8029M7	15-8036M10.5
15-8030M7.5	15-8037M11
15-8031M8	15-8038M11.5
15-8032M8.5	15-8039M12
15-8033M9	15-8040M13
15-8034M9.5	15-8041M14
15-8035M10	15-8041M15

All Above 8" Boondock Boots \$339.95



TIMBERLAND PRO 6" BOONDOCK WORKBOOT

Composite Safety Toe. Premium waterproof leather with waterproof membrane for abrasion resistance and dry feet. Contoured tongue for comfort. Goodyear Welt construction for durable mechanical bond. Vibram rubber toe protector. Thermolite 200g insulation. Rigid external heel cup for lateral stability. Mesh lining with antimicrobial treatment for odor control. Fiberglass shank. Anti-Fatigue Technology. Rubber outsole: Timberland traction tread design. Abrasion resistant. Non-marking. Ladder Lock outsole radius. Model 91631

Model TB091631214

15-7403M7	15-7410M10.5
15-7404M7.5	15-7411M11
15-7405M8	15-7412M12
15-7406M8.5	15-7413M13
15-7407M9	15-7414M14
15-7408M9.5	15-7415M15
15-7409M10	

All 6" Boondock Boots \$279.95

TIMBERLAND PRO BOONDOCK 8" WORKBOOT - NYLON

Waterproof and feature composite safety toes, insulation and rugged Vibram rubber outsoles. Molded Timberland PRO rubber toe protector. Composite safety toe. Combination 3/4-Goodyear welt construction. Dual-purpose top hardware. Mesh lining with anti-microbial treatment for odor control. Non-metallic shank for structural support. Dynamic anti-fatigue technology polyurethane footbed. Non-metallic puncture-resistant plate. Unique finger-grip pull-on. Slip-resistant Vibram rubber outsoles are formulated to maximize traction on cold surfaces.

Model TBOA1VYP001

15-8084M7	15-8091M10.5
15-8085M7.5	15-8092M11
15-8086M8	15-8093M12
15-8087M8.5	15-8094M13
15-8088M9	15-8095M14
15-8089M9.5	15-8096M15
15-8090M10	

All Timberland Pro Boondock Nylon Boots \$339.95

TIMBERLAND PRO BOONDOCK PULL-ON BOOT

Asymmetrical composite safety toe. Premium waterproof leather with waterproof membrane. Electrical Shock Protection. Vibram outsole for optimal performance in any temperature, durability and traction. Fiberglass shank for structural support. Non-metallic puncture resistant plate. Anti-Fatigue technology polyurethane footbed for shock absorption. Molded Vibram rubber toe. Breathable and moisture-wicking lining with anti-microbial treatment for odour control. Combination three-quarter Goodyear welt/cement heel construction.

Model TBOA4499214

15-7703M7	15-7710M10.5
15-7704M7.5	15-7711M11
15-7705M8	15-7712M12
15-7706M8.5	15-7713M13
15-7707M9	15-7714M14
15-7708M9.5	15-7715M15
15-7709M10	

All Timberland Pro Boondock Pull-On Workboots \$349.95

Prices are subject to change. Check our website for up to date prices. www.mercersmarine.com



TIMBERLAND PRO WINTER 8" BOONDOCK WORKBOOT

Vibram Fire & Ice Rubber outsole. Composite toe. Full grain leather upper. Thermolite 1000g insulation. Waterproof. Vibram rubber toe protector for increased abrasion resistance and durability, Rigid external heel cup for lateral stability, Dual-purpose top hardware for instant lacing customization and increased durability, Timberland traction tread design, Abrasion resistant, Non-marking, Ladder Lock outsole radius.

Model TB0A131D001

15-7455M7	15-7462M10.5
15-7456M7.5	15-7463M11
15-7457M8	15-7464M12
15-7458M8.5	15-7465M13
15-7459M9	15-7466M14
15-7460M9.5	15-7467M15
15-7461M10	

All Winter Boondock Boots \$359.95



TIMBERLAND PRO GRIDWORKS 8" WORKBOOT - LINED

Premium waterproof leather with waterproof membrane. Mesh lining with anti-microbial treatment for odor control. Alloy safety toe. Non-metallic shank for structural support. Dynamic Anti-fatigue technology. Polyurethane footbed. Non-metallic puncture resistant plate. Rubber toe. Unique "fingergrip" pull on technology. Dual purpose top hardware. Low temperature formulation maximizes traction on cold surfaces and extends flexibility in cold environments. Slip resistant. Abrasion resistant. Oil resistant. Flat wedge outsole for maximum ground contact and traction.

Brown Model TB0A12EZ214

15-7442M7	15-7449M10.5
15-7443M7.5	15-7450M11
15-7444M8	15-7451M12
15-7445M8.5	15-7452M13
15-7446M9	15-7453M14
15-7447M9.5	15-7454M15
15-7448M10	



Black Model TB0A12E0001

15-7468M7	15-7475M10.5
15-7469M7.5	15-7476M11
15-7470M8	15-7477M12
15-7471M8.5	15-7478M13
15-7472M9	15-7479M14
15-7473M9.5	15-7480M15
15-7474M10	

All Lined Gridworks Boots \$269.95



TIMBERLAND PRO 8" MAGNITUDE WORKBOOT

Premium waterproof leather with a waterproof membrane. Asymmetrical composite safety toe. Electrical shock protection. Lightweight and abrasion-resistant All Weather TPU outsole. Fiberglass shank for structural support. Non-metallic puncture-resistant plate. Anti-Fatigue technology polyurethane footbed for shock absorption and energy return. ExoShock toe reinforcement layers TPU and PU to distribute impact over a larger area, enhancing durability and reducing weight. Dual-purpose top hardware for lacing customization. Rigid external heel cup for lateral stability. Breathable and moisture-wicking lining with antimicrobial treatment for odor control. Cement construction for flexibility.

Black - Model TB0A5X27001

15-7782M7	15-7789M10.5
15-7783M7.5	15-7790M11
15-7284M8	15-7791M12
15-7785M8.5	15-7792M13
15-7786M9	15-7793M14
15-7787M9.5	15-7794M15
15-7788M10	



Brown - Model TB0A5X2U214

15-7796M7	15-7803M10.5
15-7797M7.5	15-7804M11
15-7798M8	15-7805M12
15-7799M8.5	15-7806M13
15-7800M9	15-7807M14
15-7801M9.5	15-7808M15
15-7802M10	

All 8" Magnitude Boots \$249.95



TIMBERLAND PRO 8" PAC MAX WORKBOOT

Asymmetrical composite safety toe. Premium Waterproof and abrasion resistant leather with a waterproof membrane. Electrical Hazard Protection. Metal and Mutilation Free. Lightweight and abrasion resistant All-Weather TPU outsole. Fiberglass shank for structural support. Non-metallic puncture resistant plate. Anti-Fatigue technology polyurethane footbed for shock absorption and energy return. Dual-purpose top hardware for lacing customization. Rigid external heel cup for lateral stability. Breathable and moisture-wicking lining with anti-microbial treatment for odor control. Cement construction for flexibility.

Model TB0A5XQJ001

15-7772M7	15-7777M12
15-7773M8	15-7778M13
15-7774M9	15-7779M14
15-7775M10	15-7780M15
15-7776M11	

All 8" Pac Max Boots \$374.95



TIMBERLAND 8" ENDURANCE WORKBOOT

Premium waterproof full-grain leather uppers with waterproof membranes. Composite safety toes feature CarbonShield™ technology for extra durability. Direct-inject construction. 200g Thinsulate insulation. Non-metallic puncture-resistant plates. Fiberglass shank for structural support. Mesh linings with antimicrobial treatment for odor control and comfort. Anti-fatigue polyurethane footbeds reduce shock and return energy to the foot. Non-marking, all-weather thermal plastic urethane (TPU) outsole is slip-resistant, oil resistant and heat resistant.

Black Model TB0A1Q6Z001

15-7253M7	15-7260M10.5
15-7254M7.5	15-7261M11
15-7255M8	15-7262M12
15-7256M8.5	15-7263M13
15-7257M9	15-7264M14
15-7258M9.5	15-7265M15
15-7259M10	

Brown Model TB0A1RW2214

15-7266M7	15-7273M10.5
15-7267M7.5	15-7274M11
15-7268M8	15-7275M12
15-7269M8.5	15-7276M13
15-7270M9	15-7277M14
15-7271M9.5	15-7278M15
15-7272M10	

All 8" Endurance Boots \$299.95

TIMBERLAND PRO 8" ENDURANCE MET GUARD

These Timberland PRO Endurance safety toe work boots feature an internal metatarsal guard. Premium full-grain leather uppers. Composite safety toes. Anti-fatigue technology reduces shock. Electrical shock protection. Mesh lining with antimicrobial treatment for odor control and comfort. Dual-purpose cast metal top hardware. Fiberglass shank for structural support. Timberland PRO rubber outsole is slip, oil and heat resistant.

Black/Orange Model TB0AIWUT001

15-7742M7	15-7749M10.5
15-7743M7.5	15-7750M11
15-7744M8	15-7751M11.5
15-7745M8.5	15-7752M12
15-7746M9	15-7753M13
15-7747M9.5	15-7754M14
15-7748M10	15-7755M15

All 8" Endurance Met Guard Boots \$319.95

www.mercersmarine.com





- Always Open
- Sale & Feature items
- View Catalogue



- Thousands of products
- Updated Regularly
- Up to date Pricing



- Mobile Friendly
- Shop from anywhere at anytime

Also find us on   



TIMBERLAND PRO TRAILWIND WORKBOOT

Premium full-grain waterproof leather with a waterproof membrane. Asymmetrical composite safety toe. Electrical shock protection. Lightweight foam midsole for industry-leading underfoot comfort, flexibility, and durability. Non-metallic puncture-resistant plate. Vibram outsole for enhanced durability and traction. Non-metallic shank for structural support. Anti-Fatigue Technology polyurethane footbed. Breathable and moisture-wicking lining with antimicrobial treatment for odor control.

Brown Model TBOA1VN214

15-7729M7	15-7736M10.5
15-7730M7.5	15-7737M11
15-7731M8	15-7738M12
15-7732M8.5	15-7739M13
15-7733M9	15-7740M14
15-7734M9.5	15-7741M15
15-7735M10	

All Trailwind WorkBoots \$259.95



TIMBERLAND RADIUS SAFETY SHOE

Asymmetrical composite safety toe. Electrical shock protection. Metal and mutilation free. Fuel- and oil-resistant, lightweight foam midsole, providing industry-leading underfoot comfort, flexibility, and durability. Non-metallic puncture-resistant plate. Anti-Fatigue Technology polyurethane footbed for shock absorption and energy return. Breathable, durable mesh upper with abrasion-resistant reinforcements. Breathable and moisture-wicking lining with antimicrobial treatment for odor control. Cement construction for flexibility.

Black/Orange Model TBOA27Y3001

15-7716M7	15-7723M10.5
15-7717M7.5	15-7724M11
15-7718M8	15-7725M12
15-7719M8.5	15-7726M13
15-7720M9	15-7727M14
15-7721M9.5	15-7728M15
15-7722M10	

Radius Safety Shoes (Bk/Or) \$169.95



TIMBERLAND PRO REAXION SAFETY SHOE

Asymmetrical composite safety toe. Premium full-grain leather with waterproof membrane. Electrical Hazard Protection. Metal and mutilation free. Luggy rubber outsole. Resistant to rips, abrasions and scuffs. Fiberglass shank for structural support. Non-metallic puncture resistant plate. Anti-Fatigue Technology polyurethane footbed. Breathable and moisture-wicking lining with anti-microbial treatment for odour control.

Brown Model TBOA5QBT214

15-7756M7	15-7763M10.5
15-7757M7.5	15-7764M11
15-7758M8	15-7765M12
15-7759M8.5	15-7766M13
15-7760M9	15-7767M14
15-7761M9.5	15-7768M15
15-7762M10	

Reaxion Safety Shoes \$199.95



TIMBERLAND PRO REAXION 6" SAFETY BOOT

Premium full-grain leather with a waterproof membrane. Asymmetrical composite safety toe powered by Carbon Shield technology. Electrical hazard protection. Metal and mutilation free. Luggy rubber outsole. Resists rips, abrasions, and scuffs. Fiberglass shank for structural support. Non-metallic, puncture-resistant plate. Anti-Fatigue Technology polyurethane footbed for shock absorption and energy return. Breathable and moisture-wicking lining with antimicrobial treatment for odor control.

Model TBOA21R8001

15-8187M7	15-8194M10.5
15-8188M7.5	15-8195M11
15-8189M8	15-8196M11.5
15-8190M8.5	15-8197M12
15-8191M9	15-8198M13
15-8192M9.5	15-8199M14
15-8193M10	15-8200M15

All Reaxion Safety Boots \$209.95



TIMBERLAND RADIUS SAFETY SHOE

Asymmetrical composite safety toe. SD+ protection. Metal and mutilation free. Fuel- and oil-resistant, lightweight foam midsole, providing industry-leading underfoot comfort, flexibility, and durability. Non-metallic puncture-resistant plate. Anti-Fatigue Technology polyurethane footbed for shock absorption and energy return. Breathable, durable mesh upper with abrasion-resistant reinforcements. Breathable and moisture-wicking lining with antimicrobial treatment for odor control. Cement construction for flexibility.

Model TBOA2A55001

15-8264M7	15-8271M10.5
15-8265M7.5	15-8272M11
15-8266M8	15-8273M12
15-8267M8.5	15-8274M13
15-8268M9	15-8275M14
15-8269M9.5	15-8276M15
15-8270M10	

Radius Safety Shoes (Black) \$169.95



TIMBERLAND PRO DRIVETRAIN SAFETY SHOE

These Drivetrain slip-on composite safety toe shoes are metal and mutilation free, and feature electrical hazard protection and anti-fatigue technology.

Brown Model TBOA21X7214

15-8201M7	15-8208M10.5
15-8202M7.5	15-8209M11
15-8203M8	15-8210M12
15-8204M8.5	15-8211M13
15-8205M9	15-8212M14
15-8206M9.5	15-8213M15
15-8207M10	

All Drivetrain Safety Shoes \$179.95



LADIES TIMBERLAND PRO BOONDOCK

Asymmetrical composite safety. Premium waterproof leather with waterproof membrane. Electrical Shock Protection. Vibram Fire & Ice outsole for optimal performance in any temperature. Fiberglass shank for structural support. Non-metallic puncture plate. Anti-Fatigue technology polyurethane footbed for shock absorption and energy return. Dual-purpose top hardware for lacing customization. Vibram molded rubber toe for extreme durability. Breathable and moisture-wicking lining with anti-microbial treatment for odour control. Rigid external heel cup for lateral stability.

Black Model TB0A5R7K001	
15-7811M6	15-7816M8.5
15-7812M6.5	15-7817M9
15-7813M7	15-7818M9.5
15-7814M7.5	15-7819M10
15-7815M8	15-7820M11

All Ladies Boondock Boots \$319.95



LADIES TIMBERLAND PRO 6" BOONDOCK

Asymmetrical composite safety. Premium waterproof leather with waterproof membrane. Electrical Shock Protection. Vibram Fire & Ice outsole for optimal performance in any temperature. Fiberglass shank for structural support. Non-metallic puncture plate. Anti-Fatigue technology polyurethane footbed for shock absorption and energy return. Dual-purpose top hardware for lacing customization. Vibram molded rubber toe for extreme durability. Breathable and moisture-wicking lining with anti-microbial treatment for odour control. Rigid external heel cup for lateral stability.

Brown Model TB0A5RXX214	
15-7824M6	15-7829M8.5
15-7825M6.5	15-7830M9
15-7826M7	15-7831M9.5
15-7827M7.5	15-7832M10
15-7828M8	15-7833M11

All Ladies 6" Boondock Boots \$299.95



TIMBERLAND PRO REAXION SAFETY SHOE

Abrasion-resistant ripstop nylon for lightweight and breathable performance. Asymmetrical composite safety toe powered by Carbon Shield technology. Electrical shock protection. Metal and mutilation free. Luggy rubber outsole with anatomically positioned flex grooves. TPU-wrapped Aerocore midsole for maximum energy return while resisting rips, abrasions, and scuffs. Fiberglass shank for structural support. Non-metallic puncture-resistant plate. Anti-Fatigue Technology polyurethane footbed for shock absorption and energy return. Breathable and moisture-wicking lining with antimicrobial treatment for odor control. Cement construction for flexibility.

Black/Purple Model TB0A21VB001	
15-8239M6	15-8244M8.5
15-8240M6.5	15-8245M9
15-8241M7	15-8246M9.5
15-8242M7.5	15-8247M10
15-8243M8	15-8248M11

All Ladies Reaxion Safety Shoes \$159.95



TIMBERLAND PRO LADIES ENDURANCE WORKBOOT

Premium full-grain waterproof leather with waterproof membrane. Composite safety toe powered by CarbonShield Technology. Non-metallic puncture plate. Direct inject construction. Non metallic shank. Brass eyelets with zinc dual purpose top hooks. Anti-fatigue technology polyurethane footbed for shock absorption and energy return. Mesh lining with anti-microbial treatment for odor control.

Wheat Model TB0A22SD231		Black Model TB0A1KQS001	
15-8125M6	15-8130M8.5	15-8137M6	15-8142M8.5
15-8126M6.5	15-8131M9	15-8138M6.5	15-8143M9
15-8127M7	15-8132M9.5	15-8139M7	15-8144M9.5
15-8128M7.5	15-8133M10	15-8140M7.5	15-8145M10
15-8129M8	15-8134M11	15-8141M8	15-8146M11

All Ladies Timberland Pro Endurance Boots \$269.95



TIMBERLAND PRO LADIES RADIUS SAFETY SHOE

Built on a women's specific last for optimal fit and comfort. Asymmetrical composite safety toe. Electrical shock protection. Metal and free. Non-metallic puncture-resistant plate. Fuel- and oil-resistant, lightweight HoverSpring foam midsole, providing industry-leading underfoot comfort, flexibility, and durability. Anti-Fatigue Technology polyurethane footbed for shock absorption and energy return. Breathable, durable mesh upper with abrasion-resistant reinforcements. Breathable and moisture-wicking lining with antimicrobial treatment for odor control. Cement construction for flexibility.

Black/Purple Model TB0A285Z001	
15-8279M6	15-8284M8.5
15-8280M6.5	15-8285M9
15-8281M7	15-8286M9.5
15-8282M7.5	15-8287M10
15-8283M8	15-8288M11

All Ladies Radius Safety Shoes \$169.95

NEW



JB GOODHUE
 
WATERPROOF METAL FREE

NEW



JB GOODHUE
 
WATERPROOF METAL FREE

NEW



JB GOODHUE
 

JB GOODHUE MAXXUM 5 WORKBOOT

Full grain Waterproof leather upper. PRO-DRI Waterproof system, with membrane. Composite toe. METAL FREE plus LENZI composite plate for added flexibility. Waterproof. Contoured padded top gives better fit & support along lower Achilles tendon. Padded collar & Leather tongue offers extra comfort. Extra deep toe area accommodates orthopedic devices. 200g Thinsulate insulation. Cambrella lining, engineered to add comfort, durability & moisture management. Helcor high abrasion toe & heel guard for added wear protection. WELTREK II Goodyear welt construction. Outsole: aggressive lug, oil resistant rubber with lightweight PU midsole. Slip Resistant.

Black (17102)

14-4983M7	14-4989M10
14-4984M7.5	14-4990M10.5
14-4985M8	14-4991M11
14-4986M8.5	14-4992M12
14-4987M9	14-4993M13
14-4988M9.5	

Brown (17104)

14-4996M7	14-5002M10
14-4997M7.5	14-5003M10.5
14-4998M8	14-5004M11
14-4999M8.5	14-5005M12
14-5000M9	14-5006M13
14-5001M9.5	

All JB Goodhue Maxxum 5 Boots \$269.95

JB GOODHUE "5 STAR" WORKBOOT

360 degrees of features make the 5 star general a top of the line choice for durability and performance. Full-grain water-resistant leather upper, contoured padded top for better support along Achilles tendon, and an off-centre last.

Brown - Model 07861

14-5073M7	14-5081M11
14-5075M8	14-5082M12
14-5077M9	14-5083M13
14-5079M10	14-5084M14

All JB Goodhue 5 Star Boots \$319.95

NEW



JB GOODHUE
 
WATERPROOF METAL FREE



JB GOODHUE
 
WATERPROOF METAL FREE

NEW



JB GOODHUE
 

JB GOODHUE TANKER 5 WORKBOOT

You need a workboot that works just as hard as you do. The brand new Tanker 5.0 boot has an off-centre last to follow the natural shape and rotation of your foot, endurance muscle lace that's built to last, and a fully aerospace lining to keep your feet warm and dry. Constructed with the toughest, most durable materials – top quality black pit leather, a composite lenzi plate for flexibility, and made with rocker design for extra toe spring to help you crush 10,000 steps a day without fatigue. The Tanker 5.0 is built for work.

Black (17177)

14-5009M7	14-5015M10
14-5010M7.5	14-5016M10.5
14-5011M8	14-5017M11
14-5012M8.5	14-5018M12
14-5013M9	14-5019M13
14-5014M9.5	

Brown (17178)

14-5022M7	14-5028M10
14-5023M7.5	14-5029M10.5
14-5024M8	14-5030M11
14-5025M8.5	14-5031M12
14-5026M9	14-5032M13
14-5027M9.5	

All JB Goodhue Tanker 5 Boots \$279.95

JB GOODHUE BIONIC INSULATED WORK BOOT

CSA APPROVED. Composite toe and plate. Metal Free. Waterproof. Vibram Ghiaccio arctic grip outsole. 1400 grams of Zonal Thinsulate: 800 grams in the footbed 600 grams in the shaft.

Black Model 30909

14-5064M8	14-5070M12
14-5065M9	14-5071M13
14-5067M10	14-5072M14
14-5069M11	

All Bionic Ins. Workboots \$319.95



JB GOODHUE

Side Zipper



JB GOODHUE



JB GOODHUE

NON-METALLIC



JB GOODHUE SIDEZIP JET WORKBOOTS

8" uniform sidezip boot with YKK zipper. Breathable waterproof Pro Dri membrane. Leather upper. Composite LENZI plate for added flexibility. Air mesh lining wicks away moisture. 2E width. Ultra soft PU comfort insole. Lightweight and flexible PU midsole. High abrasive resistant non-slip PU outsole.

Black Model 30707

14-4684M4	14-4692M9.5
14-4685M5	14-4693M10
14-4686M6	14-4694M10.5
14-4687M7	14-4695M11
14-4688M7.5	14-4696M12
14-4689M8	14-4697M13
14-4690M8.5	14-4698M14
14-4691M9	

Brown Model 30708

14-4699M4	14-4707M9.5
14-4700M5	14-4708M10
14-4701M6	14-4709M10.5
14-4702M7	14-4710M11
14-4703M7.5	14-4711M12
14-4704M8	14-4712M13
14-4705M8.5	14-4713M14
14-4706M9	

All JB Goodhue Sidezip Jet Boots \$199.95

JB GOODHUE "THRASHER" WORKBOOT

Waterproof Nubuck leather upper. Padded collar & tongue offers extra comfort. Armor Guard™ metal free consisting of: KEVLAR® composite toe and LENZI® composite plate. Extra deep toe area accommodates orthopedic devices. Lightweight and flexible PU midsole. High abrasive resistant, slip resistant, PU/TPU outsole.

Model 30706

14-18884M7	14-18890M10
14-18885M7.5	14-18891M10.5
14-18886M8	14-18892M11
14-18887M8.5	14-18893M12
14-18888M9	14-18894M13
14-18889M9.5	

All JB Goodhue Thrasher Boots \$209.95



JB GOODHUE



JB GOODHUE



JB GOODHUE



JB GOODHUE NITRO 2 WORKBOOT

The Nitro is a powerful workboot incorporating state of the art durable materials and construction to make this boot tough as nails. Starting with full-grain buffalo leather, cambrelle lining, TPU bumper toe for safety, and a lightweight midsole for ease of wear. 3E width. Oil resistant sole and high abrasive resistant outsole make the nitro a safe and powerful boot for any tough day on the job site.

Brown Model 14009

14-18925M7	14-18933M11
14-18927M8	14-18934M12
14-18929M9	14-18935M13
14-18931M10	

Black Model 14008

14-18936M7	14-18944M11
14-18938M8	14-18945M12
14-18940M9	14-18946M13
14-18942M10	

All JB Goodhue Nitro 2 Workboots \$174.95

JB GOODHUE "DYNAMIC" WORKBOOT

Exceptional slip resistance, protection from the elements, and a comfort and durability you can trust in the Dynamic boot. Starting with a nubuck water-resistant leather upper that will keep you warm and dry, an air mesh lining to wick away moisture, and a bumper toe guard to keep you safe. The Dynamic is completed with a high-abrasive resistant non-slip outsole and an oil resistant sole. Full leather tongue. 3E width. Lightweight and flexible PU midsole.

Tan Model 14080

14-9489M7	14-9497M11
14-9491M8	14-9499M12
14-9493M9	14-9500M13
14-9495M10	

All Dynamic Workboots \$189.95



JB GOODHUE

JB GOODHUE "IRONWORKER" WORKBOOT

The Ironworker is a boot that is built to last. The soles are welted on creating a seamless fit with the shoe and, compared to soles that are simply glued on. The outsoles themselves are sprayed with an oil-resistant compound to keep your feet securely grounded. Ironworker has a full-grain leather upper, to contour to your feet. To make the shoe fit your feet perfectly; the Ironworker laces start at the toe. The leather tongue also adds extra padding and will wear well over time.

Model 00800 with Toe Cap

14-18908M5	14-18920M11
14-18910M6	14-18921M12
14-18912M7	14-18922M13
14-18914M8	14-18923M14
14-18916M9	14-18924M15
14-18918M10	

All Ironworker Workboots \$209.95



JB GOODHUE



WATERPROOF

JB GOODHUE RIGGER LINED WORKBOOT

The Rigger boot is engineered specifically to provide workers in the oil and gas industries with superior safety and protection. The Rigger is stitched to last with a Pro Dri Waterproof system with membrane, lace to toe design for better fit, lightweight phylon midsole and oil resistant outsole, a high-profile toe cap and the best method of construction on the market for work boots – goodyear welt construction ensuring The Rigger workboot lasts just as long as you do.

Black Model 07885

14-4714M7	14-4722M11
14-4716M8	14-4723M12
14-4718M9	14-4724M13
14-4720M10	

Tan Model 07889

14-4970M7	14-4978M11
14-4972M8	14-4979M12
14-4974M9	14-4980M13
14-4976M10	

All JB Goodhue Rigger Lined Workboots \$259.95



JB GOODHUE



WATERPROOF



JB GOODHUE



METAL FREE

JB GOODHUE THUNDER WORKBOOT

Long days on the jobsite demand a boot that is up to task. The Thunder workboot is crafted to be durable and comfortable with a full-grain leather upper and a padded collar and tongue. Armor Guard metal free consisting of: composite toe and LENZI composite plate, for flexible protection from workplace hazards, and an extra deep toe area to accommodate orthopedic devices. Lightweight and flexible PU midsole. The Thunder boot is built for work. High abrasive resistant, slip resistant outsole.

Black Model 30700

14-18689M7	14-18697M11
14-18691M8	14-18698M12
14-18693M9	14-18699M13
14-18695M10	

Brown Model 30750

14-18702M7	14-18710M11
14-18704M8	14-18711M12
14-18706M9	14-18712M13
14-18708M10	

All JB Goodhue Thunder Workboots \$189.95

JB GOODHUE



METAL FREE

JB GOODHUE "CYCLONE" SAFETY SHOE

Full grain leather upper. Padded collar & tongue offer extra comfort. Armor Guard metal free consisting of: KEVLAR composite toe and LENZI composite plate. Lightweight and flexible PU midsole. High abrasive resistant, slip resistant outsole. Outsole PU/TPU. Extra deep toe area accommodates orthopedic devices. CSA-1

Model 30500

14-18666M7	14-18674M11
14-18668M8	14-18675M12
14-18670M9	14-18676M13
14-18672M10	

All Cyclone Safety Shoes \$169.95





BAFFIN



BAFFIN



BAFFIN



Workboots

BAFFIN MONSTER 8" WORKBOOT

Waterproof leather with breathable membrane and comfort padded top collar. Corrosion resistant top hardware and catch resistant speed lacing system. Rubber toe guard and TPU external heel counter. Composite safety toe and plate. Lateral roll bars and heel cup for high-performance stability. Dual density polyurethane mid-sole provides insane comfort. Anti-fatigue technology absorbs shock and return energy. Oil and acid resistant rubber outsole. Slip resistant sole features deep lugs which provide exceptional durability and traction.

Brown		Black	
14-3655M7	14-3662M11	14-3667M7	14-3674M11
14-3656M8	14-3663M12	14-3668M8	14-3675M12
14-3658M9	14-3664M13	14-3670M9	14-3676M13
14-3660M10	14-3665M14	14-3672M10	14-3677M14

Baffin 8" Monster Workboots \$249.95

BAFFIN ICE MONSTER 8" WORKBOOT

For an all encompassing year-round safety boot, ICE MONSTER is equipped with slip-resistance features and anti-fatigue technology for shock absorption and energy return. Built for diverse environments with both wet and icy conditions. Work in confidence with a boot that is CSA/ASTM approved and ESR/EH rated.

- Waterproof Level: B-Tek Dry Waterproof Breathable
- Insulation Level: Fixed-Fit multi-layer inner boot system

14-3679M7	14-3686M11
14-3680M8	14-3687M12
14-3682M9	14-3688M13
14-3684M10	14-3689M14

Baffin 8" ICE Monster Workboots \$259.95



NEW

BAFFIN



BAFFIN MONSTER (INTERNAL METATARSAL) 8" WORKBOOT

For an all encompassing year-round safety boot, MONSTER INT (MET) is equipped with slip-resistance features and anti-fatigue technology for shock absorption and energy return. Work in confidence with a series that is CSA/ASTM approved and ESR/EH rated. Foundational and functional performance for the active lifestyle.

- Insulation Level: Fixed-Fit multi-layer inner boot system
- Waterproof Level: B-Tek Dry Waterproof Breathable

14-3691M7	14-3698M11
14-3692M8	14-3699M12
14-3694M9	14-3700M13
14-3696M10	14-3701M14

Baffin 8" Monster (Internal Metatarsal) Workboots \$264.95



FOOTWEAR



ACTON THOR 8" WORKBOOT

2mm waterproof full grain leather upper with triple sealed seams. Breathable mesh lining with antimicrobial treatment. 200 g of Thinsulate insulation surrounding the foot. Scuff resistant TPU toe cap for increased wear protection. Lightweight and non-conductive composite toe and puncture-resistant plate. Removable insole made of PU foam to maximize shocks absorption and for a long-lasting comfort. Nylon polycarbonate shank. Dual density outsole made of natural rubber 4Grip outsole, slip resisting on frosted surfaces and lightweight PU Core. Absorb+ heel, absorbing shock impacts during impact and increasing grip. 90° heel angle. Padded tongue and collar allowing extra comfort.

Model A9275-12

15-2169M7	15-2176M11
15-2170M8	15-2177M12
15-2172M9	15-2178M13
15-2174M10	15-2179M14

All Acton Thor Workboots \$209.95



ACTON G3T 8" WORKBOOT

2 mm waterproof full grain leather upper with triple sealed seams with handles for quick donning. Breathable and abrasion resistant microfiber lining with antimicrobial treatment. Waterproof and breathable Drylock II membrane. 200 g of Thinsulate insulation surrounding the foot. Lightweight and non-conductive composite toe and puncture-resistant plate. Removable insole made of PU and memory foam offering breathability, comfort and great shock absorption. Dual density outsole made of natural rubber and lightweight PU core. Natural rubber 4Grip slip resisting outsole, on dry, wet and oily surfaces, resistant to wear and oil. PU scuff resistant toe cap for increased wear protection. Nylon polycarbonate shank. Polymer eyelets. High visibility reflective inserts. Extra wide fit for more room and comfort. Absorb+ heel, absorbing shock impacts during impact and increasing grip. 90° heel angle. Padded tongue and collar.

Model A9060B-11

15-2184M7	15-2192M12
15-2185M8	15-2193M13
15-2187M9	15-2194M14
15-2189M10	15-2195M15
15-2191M11	

All Acton G3T Workboots \$244.95



ACTON MAGNETIC WORKBOOT

Thinsulate insulation and metal-free construction. CSA Protective toe cap. Sole puncture protection. Removable insoles. Metal free. Waterproof natural rubber upper.. Waterproof construction. Energy absorber heel with an angle of 90°. Waterproof membrane. Breathable textile lining. Non metallic shank. Breathable and fast drying.

Model A9237-11

15-2154M6	15-2163M11
15-2155M7	15-2164M12
15-2157M8	15-2165M13
15-2159M9	15-2166M14
15-2161M10	

All Acton Magnetic Workboots \$244.95



www.mercersmarine.com

- Always Open
- Sale & Feature items
- View Catalogue
- Thousands of products
- Updated Regularly
- Up to date Pricing
- Mobile Friendly
- Shop from anywhere at anytime





ACTON G3U WORKBOOT

Height : 8". 2 mm waterproof full grain leather upper with triple sealed seams with handles for quick donning. Breathable mesh lining with antimicrobial treatment. Waterproof and breathable Drylock II membrane. 200 g of Thinsulate insulation surrounding the foot. Lightweight and non-conductive composite toe and puncture-resistant plate. Removable insole made of PU and memory foam offering breathability, comfort and great shock absorption. Dual density outsole made of natural rubber and lightweight PU core. Natural rubber 4Grip slip resisting outsole, on dry, wet, oily, frosted surfaces; resistant to wear and oil. PU scuff resistant toe cap for increased wear protection. Nylon polycarbonate shank. Polymer eyelets. High visibility reflective inserts. Extra wide fit for more room and comfort. Absorb+ heel, absorbing shock impacts during impact and increasing grip. 90° heel angle. Padded tongue and collar.

Model A9260-12

15-2458M8	15-2466M13
15-2460M9	15-2467M14
15-2462M10	15-2468M15
15-2464M11	15-2469M16
15-2465M12	

All Acton G3U Workboots \$239.95



JB GOODHUE BOLT LO SAFETY SHOE

Premium Knitting Mesh with TPU film overlay. Padded collar & tongue offers extra comfort. Removeable PU Comfort Insole. Composite toe and plate. Lightweight and flexible EVA midsole. High abrasive resistant, slip resistant outsole. Outsole RUBBER. Extra deep toe area accommodates orthopedic devices.

Black Model 31016

14-5043M8	14-5049M11
14-5045M9	14-5050M12
14-5047M10	14-5051M13

All Bolt Lo Safety Shoes \$144.95



ACTON G30 WORKBOOT

Height : 8". 2 mm waterproof full grain leather and PU coated nylon upper with triple sealed seams. Lightweight and non-conductive composite toe and puncture-resistant plate. Breathable and abrasion resistant Cambrelle lining with antimicrobial treatment. Removable insole made of PU and memory foam offering breathability, comfort and great shock absorption. Extra wide fit for more room and comfort. Nylon polycarbonate shank. PU scuff resistant toe cap for increased wear protection. Dual density outsole made of natural rubber and lightweight PU core. Natural rubber 4Grip slip resisting outsole, on dry, wet and oily surfaces, resistant to wear and oil. Polymer eyelets. High visibility reflective inserts. Absorb+ heel, absorbing shock impacts during impact and increasing grip. 90° heel angle. Padded tongue and collar.

Model A9067B-12

15-2441M8	15-2448M12
15-2443M9	15-2449M13
15-2445M10	15-2450M14
15-2447M11	

All Acton G30 Workboots \$204.95



JB GOODHUE LADIES MAVIS SAFETY SHOE

Premium Knitting Mesh with KPU film overlay. Padded collar & tongue offers extra comfort. Removeable PU Comfort Insole. Steel toe and plate. Lightweight and flexible EVA midsole. High abrasive resistant, slip resistant outsole. Outsole EVA RUBBER. Extra deep toe area accommodates orthopedic devices.

Black Model 52400

14-5054M6	14-5059M8.5
14-5055M6.5	14-5060M9
14-5056M7	14-5061M9.5
14-5057M7.5	14-5062M10
14-5058M8	

All Ladies Mavis Safety Shoes \$119.95



ACTON CANNONBALL WORKBOOT

Natural rubber 4GRIP outsole. Protector side support. Anti-torsion polypropylene insole. Composite toe protector. Antipuncture non metallic plate. Internal Poron XRDTM metguard protection. CSA grade 1 and ESR certified. Energy absorber heel with an angle of 90°. High visibility reflective inserts. 1000g Thinsulate insulation. CosmoTM Comfort LUNAR lining. Breathable waterproof Sympatex membrane. Padded ankle protection. Removable multi-layered molded insulating insole. Natural rubber and EVA core outsole. Padded collar and tongue for added comfort. 2 mm waterproof leather upper with sealed seams. Bumper toe protector. AEGIS™ antimicrobial treatment. Speed lace system. Extra wide fit for more room and comfort.

Model A9076-11

14-507M7	14-514M11
14-508M8	14-515M12
14-510M9	14-516M13
14-512M10	14-517M14

All Acton Cannonball Workboots \$299.95



ACTON LINCOLN WORKSHOE

Waterproof microfiber upper, resistant to animal fat, blood and most chemicals. Steel toe and lightweight composite puncture-resistant plate. Breathable Taibrelle lining with antimicrobial treatment. Removable insole with anti-fatigue latex foam at the heel. Fiberglass shank. Dual density outsole made of natural rubber and lightweight EVA core. Natural rubber 4Grip outsole, slip resisting on dry, wet and oily surfaces, resistant to wear and oil.

Model A9115-11

15-2473M7	15-2480M11
15-2474M8	15-2481M12
15-2476M9	15-2482M13
15-2478M10	15-2483M14

All Acton Lincoln Workshoes \$119.95



KEEN CAMDEN WORKBOOT

Non-metallic carbon-fiber toes. Waterproof, breathable membrane. Oil and slip-resistant non-marking rubber outsole. Electric Shock Resistant. ASTM/CSA-Certified, internal, metatarsal guard is flexible and lightweight for comfort. ASTM/CSA-certified, non-metallic, puncture resistant midsole plate for underfoot protection. Full-grain barnyard resistant waterproof leather. Removable, dual-density footbed provides breathability to help keep feet cool in warm environments. Environmentally preferred premium leather.

Model 1027693

15-9000M7	15-9007M10.5
15-9001M7.5	15-9008M11
15-9002M8	15-9009M11.5
15-9003M8.5	15-9010M12
15-9004M9	15-9011M13
15-9005M9.5	15-9012M14
15-9006M10	15-9013M15

All Keen Camden Workboots \$329.95



KEEN CINCINNATI WORKBOOT

Non-metallic carbon-fiber toes. Waterproof, breathable membrane. Oil and slip-resistant non-marking rubber outsole. Electric Shock Resistant. ASTM/CSA-certified, non-metallic, flexible woven-textile puncture resistant midsole plate for underfoot protection. Full-grain barnyard resistant waterproof leather. Removable, dual-density footbed provides breathability to help keep feet cool in warm environments. Environmentally preferred premium leather.

Model 1028288

15-9014M7	15-9021M10.5
15-9015M7.5	15-9022M11
15-9016M8	15-9023M11.5
15-9017M8.5	15-9024M12
15-9018M9	15-9025M13
15-9019M9.5	15-9026M14
15-9020M10	15-9027M15

All Keen Cincinnati Workboots \$304.95



KEEN ABITIBI II WORKBOOT

Non-metallic carbon-fiber toes offer unobtrusive fit and are 15% lighter than steel. Waterproof, breathable membrane. ASTM/CSA-certified, non-metallic, flexible woven-textile puncture resistant midsole plate for underfoot protection. Locked-in feel. Nylon shank for midfoot support. 90° heel provides stability and helps catch or lock the foot in place. Electric Shock Resistant. Environmentally preferred premium leather. PFC-Free, durable water repellent.

Model 1026789

15-9028M7	15-9035M10.5
15-9029M7.5	15-9036M11
15-9030M8	15-9037M11.5
15-9031M8.5	15-9038M12
15-9032M9	15-9039M13
15-9033M9.5	15-9040M14
15-9034M10	15-9041M15

All Keen Abitibi Workboots \$304.95



KEEN OSHAWA WORKBOOT - SIDE ZIP

Non-metallic carbon-fiber toes offer unobtrusive fit and are 15% lighter than steel. Waterproof, breathable membrane. ASTM/CSA-certified, non-metallic, flexible woven-textile puncture resistant midsole plate for underfoot protection. Nylon shank for midfoot support. 90° heel provides stability and helps catch or lock the foot in place. Electric Shock Resistant. Environmentally preferred premium leather. PFC-Free, durable water repellent.

Model 1022107

15-9084M7	15-9091M10.5
15-9085M7.5	15-9092M11
15-9086M8	15-9093M11.5
15-9087M8.5	15-9094M12
15-9088M9	15-9095M13
15-9089M9.5	15-9096M14
15-9090M10	15-9097M15

All Keen Oshawa Workboots \$284.95



KEEN DAVENPORT WORKBOOT

Non-metallic composite toes are 10% lighter than steel. Waterproof, breathable membrane. TPU shank for midfoot support. 90° heel provides stability and helps catch or lock the foot in place. Electric Shock Resistant. Environmentally preferred premium leather. PFC-Free, durable water repellent.

Model 1017799

15-9056M7	15-9063M10.5
15-9057M7.5	15-9064M11
15-9058M8	15-9065M11.5
15-9059M8.5	15-9066M12
15-9060M9	15-9067M13
15-9061M9.5	15-9068M14
15-9062M10	15-9069M15

All Keen Davenport Workboots \$284.95



KEEN HAMILTON WORKBOOT

Non-metallic carbon-fiber toes offer unobtrusive fit and are 15% lighter than steel. Waterproof, breathable membrane. ASTM/CSA-certified, non-metallic, flexible woven-textile puncture resistant midsole plate for underfoot protection. Reflective webbing for additional safety and visibility. 90° heel provides stability and helps catch or lock the foot in place. Electric Shock Resistant. Environmentally preferred premium leather. PFC-Free, durable water repellent.

Model 1020096

15-9042M7	15-9049M10.5
15-9043M7.5	15-9050M11
15-9044M8	15-9051M11.5
15-9045M8.5	15-9052M12
15-9046M9	15-9053M13
15-9047M9.5	15-9054M14
15-9048M10	15-9055M15

All Keen Hamilton Workboots \$274.95



KEEN LANSING SAFETY SHOE

Left and right asymmetrical steel toes. Waterproof leather upper. Non-metallic puncture resistant midsole plate-*CSA* certified. Removable Metatomical footbed. Oil and slip resistant, non-marking rubber outsole. Torsional stability shank for midfoot support. Reflective webbing for additional safety and visibility.

Model 1021331

15-9070M7	15-9077M10.5
15-9071M7.5	15-9078M11
15-9072M8	15-9079M11.5
15-9073M8.5	15-9080M12
15-9074M9	15-9081M13
15-9075M9.5	15-9082M14
15-9076M10	15-9083M15

All Keen Lansing Safety Shoe \$169.95



GRISPORT 6" FOX WORKBOOT

Experience ultimate comfort and protection with the Grisport Fox 6 Waterproof Leather Safety Boots, featuring the durable Vibram Ranger Sole and a composite toe. Engineered for superior performance in demanding work environments, these boots are crafted from high-quality, genuine leather and packed with innovative features. Enhance your safety and comfort on the job with these top-rated, *CSA/ASTM* approved boots.

Black - Model 702301C13T

15-5120M7	15-5125M10.5
15-5121M8	15-5126M11
15-5122M8.5	15-5127M12
15-5123M9	15-5128M13
15-5124M10	

All Fox Workboots \$220.95

SHOP 24/7 FROM THE COMFORT OF YOUR OWN HOME

- Up to date Pricing
- New Products
- Stock Status
- Additional product info
- And more



www.mercersmarine.com



GRISPORT BOA WOLF WORKBOOT

Recommended for a wide range of industrial and work service applications for those who demand a premium outsole for their work boots. Durable patented Vibram PU/TPU sole, heat resistant to 300 degrees. Composite midsole & toe cap. Waterproof membrane. Waterproof Diamante covered leather. BOA closure system. Genuine leather. Scuff-resistant toe cap. Waterproof.

Black - Model 702381C2T

15-5131M7	15-5136M10.5
15-5132M8	15-5137M11
15-5133M8.5	15-5138M12
15-5134M9	15-5139M13
15-5135M10	

Brown - Model 702381C2T

15-5142M7	15-5147M10.5
15-5143M8	15-5148M11
15-5144M8.5	15-5149M12
15-5145M9	15-5150M13
15-5146M10	

All BOA Wolf Workboots \$215.95



GRISPORT MONTAGUE SAFETY SHOE

Like the other boots in the Vibram series, the composite plate provides added flexible and are lightweight with a sporty look, yet still offering the same safety features and comfort. Full grain leather upper. Breathable and water-resistant. Black Vibram TPU outsole. Lightweight Injected Polyurethane (PU) midsole. Perforated steel toe cap. Composite puncture resistant plate. Scuff resistant toe.

Black - Model 702043C5

15-5110M7	15-5115M10.5
15-5111M8	15-5116M11
15-5112M8.5	15-5117M12
15-5113M9	15-5118M13
15-5114M10	

All Montague Safety Shoes \$185.95



GRISPORT BOA CONSTRUCTOR WORKBOOT

A lightweight and comfortable boot featuring a waterproof lining to keep your feet warm and dry when out in the elements. The BOA quick release system allows quick on/off when entering homes etc. Simply turn to tighten for all-day comfort. Micro-adjustments can be made while you work, without needing to remove gloves. Full grain leather upper. Breathable and water-resistant. Black Vibram TPU outsole. Lightweight Injected Polyurethane (PU) midsole. Perforated steel toe cap. Composite puncture resistant plate. Scuff resistant toe.

Brown - Model 74693CD11K

15-5002M7
15-5003M8
15-5004M8.5
15-5005M9
15-5006M10

Black - Model 74693CD5K

15-5011M7
15-5012M8
15-5013M8.5
15-5014M9
15-5015M10
15-5016M10.5
15-5017M11
15-5018M12
15-5019M13

All BOA Constructor Workboots \$285.95

GRISPORT BOA HAWK WORKBOOT

Recommended for a wide range of industrial and work service applications for those who demand a premium outsole for their work boots. 400g insulated. Durable patented Vibram PU/TPU sole, heat resistant to 300 degrees. Composite midsole & toe cap. Waterproof membrane. Waterproof Diamante covered leather. BOA closure system. Genuine leather. Scuff-resistant toe cap. Waterproof.

Black - Model 702379C6K

15-5170M7
15-5171M8
15-5172M8.5
15-5173M9
15-5174M10
15-5175M10.5
15-5176M11
15-5177M12
15-5178M13

All BOA Hawk Workboots \$324.95



GRISPORT CALEDONIA WORKBOOT

The newest slip-on boots from Grisport! Fully composite, ultralight, breathable & Total Grip rubber sole.. Fully composite, ultralight, breathable & Total Grip rubber sole. 300 degree heat resistant sole. Cross safety outsole + PU injected midsole. Composite toe cap and midsole.

Black - Model 702033C3

15-5070M6
15-5071M7
15-5072M8
15-5073M8.5
15-5074M9
15-5075M10

Grey - Model 702033C6

15-5076M10.5
15-5077M11
15-5078M12
15-5079M13
15-5080M14
15-5081M6
15-5082M7
15-5083M8
15-5084M8.5
15-5085M9
15-5086M10
15-5087M10.5
15-5088M11
15-5089M12
15-5090M13
15-5091M14

All Caledonia Workboots \$199.95

GRISPORT MOOSE PULL ON WORKBOOT

Grisport's Moose Pull-On Winter Boot is built on the Vibram Megagrip Pro outsole, which provides a high level of performance in both grip and durability even in temperatures from -40°C. The Megagrip Pro outsole satisfies the ISO standards for protective outsoles which includes metrics for tear strength resistance, oil resistance, hot contact resistance, and flexing resistance. Recommended for a wide range of industrial and work service applications for those who demand a premium outsole for their work boots.

Brown - Model 702319CDK

15-5160M7
15-5161M8
15-5162M8.5
15-5163M9
15-5164M10
15-5165M10.5
15-5166M11
15-5167M12
15-5168M13

All Moose Pull On Workboots \$270.95



GRISPORT WATERPROOF CREAM

This cream is based on waxes, oils and greases with a very high waterproofing power. It uniforms the colour of the leather granting a pleasant fatliquored and waxy feel. Includes applicator sponge.

15-5020M.....100 ml19.95



SNO-SEAL PROTECTOR

All season leather protection. A rub-on beeswax cream.

14-834P..... 12.50



24" SHOE HORN

No more bad backs while bending over to put shoes on.

14-6410K24"7.25



WALTERS SHOE HORN

Helps ease heel into shoe. Suited for all men's and women's dress and casual shoes. Attractive tortoise shell design. 23" in length.

15-1677P 6.99



AT WORK "STEEL TOE SOCK"

Odor guard. Fortified foot bottom. Extra cushiony sole and toe. The hardest working sock in the world with a double-cushioned sole and toe box for work boot comfort. Black

12-19238M.....Med18.99

12-19239MLg18.99

12-19240MXL18.99



BATTERY OPERATED ELECTRIC SOCKS

Heavyweight 80% cotton, 20% spandex. Hard plastic battery case holds 2 x "AA" batteries (not included)

12-014MSm (7/9)37.50

12-015MMed (10/11)37.50

12-016MLg(12/13)37.50

JB GOODHUE



Workboots

JB GOODHUE INSOLES

The personalised biomechanical insole that prevents joint pain. Advanced memory comfort heel and arch stabilizer. High impact protection. Climate control. Anti-bacterial and odour resistant.

14-4896M7 14-4900M11

14-4897M8 14-4901M12

14-4898M9 14-4902M13

14-4899M10

All JB Goodhue Insoles \$24.95



STC INSTANT COMFORT INSOLES

Comfortable removable insole. Made of PU and memory foam. Fits with most of safety footwear. Antimicrobial treatment. Model 20000

15-1935M4 15-1941M10

15-1936M5 15-1942M11

15-1937M6 15-1943M12

15-1938M7 15-1944M13

15-1939M8 15-1945M14

15-1940M9

All STC Instant Comfort Insoles \$17.95



TIMBERLAND PRO ANTI-FATIGUE INSOLES

Anti-fatigue technology utilizes unique inverted cone design for lightweight support. OrthoLite top layer provides premium comfort and moisture management. Anatomically-contoured footbed cradles the foot for maximum comfort and support. Dynamic arch design adapts to all foot shapes.

15-7924MXS/4-5 15-7927MLg/10-11

15-7925MSm/6-7 15-7928MXL/12-13

15-7926MMed/8-9 15-7929M2X/14-15

All Anti-Fatigue Insoles \$39.95

FOOTWEAR



STABILIZERS LITE

Light duty serious traction gear. Multi-directional steel cleats. Best for walking & easy outdoor recreation.

14-1192KSm (4/7)41.95
14-1193KMed (7.5/10)41.95
14-1194KLg (10.5/13)41.95
14-1195KXL (13.5/16)41.95



YAKTRAX WALK

Yaktrax Walk is a lightweight and easy to use ice-traction device. Perfect for pedestrians, professionals and the elderly, the Walk provides greater stability while walking on snow or ice. The Yaktrax Walk reduces the risk of falls and injuries while walking to school, work, or just to the mailbox. Walk naturally on packed snow and ice. Spikeless, ultra lightweight design.

14-10006KXS (1 - 4.5)29.95
14-10000KSm (5 - 8.5)29.95
14-10001KMed (9 - 11)29.95
14-10002KLg (11.5 - 13.5)29.95



YAKTRAX RUN

The Yaktrax Run is an ice traction device anatomically designed for use with running shoes. Run naturally on packed snow and ice with the Yaktrax Run's combination of removable spikes and steel coils, providing 360° of unbeatable traction. Continue your training during the winter with the same stability you are accustomed to on dry surfaces.

14-10015KSm (5 - 8.5)53.95
14-10016KMed (9 - 11)53.95
14-10017KLg (11.5 - 13.5)53.95
14-10018KXL (14+)53.95



ICE TREKKERS SPIKES

Highly durable tungsten carbide soikes in an all steel housing. Very effective on icy surfaces and packed snow. Fits well over all footwear. Lightweight and easy to stow. Easy on and off. Unisex sizing.

14-10012KSm/Med29.95
14-10013KLg/XL29.95



MID SOLE ICE TRACTION CLEAT

one-size-fits-all winter traction solution ideal for a defined heel work boot. The practical and easy-to-use design drives compliance in the workplace and reduces the chance of slip and fall injuries on ice and snow. The cleats are made with durable ice-penetrating tungsten carbide spikes. The Mid-Sole cleats are different from traditional cleats as they can be rotated to the top of the boot, eliminating user hassle of removing them on work sites that require frequent indoor/outdoor transition, driving, or climbing.

14-1185MOne Size44.50
----------	---------------	------------



**Shop or Browse
Online 24/7
at
mercersmarine.com**





BAFFIN



BAFFIN



NEW

BAFFIN

Workboots

MEN'S BAFFIN COPENHAGEN

While function precedes fashion, Baffin is committed. While function precedes fashion, Baffin is committed to providing footwear that looks great too. COPENHAGEN keeps you warm, dry and comfortable from early Fall through late Spring. These boots are designed for you to wear from your house out to dinner and from the streets into your office. Specifically designed for men's fit, COPENHAGEN merges protection with pride.

Black		Brown	
14-2764P7	14-2768P11	14-2772P7	14-2776P11
14-2765P8	14-2769P12	14-2773P8	14-2777P12
14-2766P9	14-2770P13	14-2774P9	14-2778P13
14-2767P10	14-2771P14	14-2775P10	14-2779P14

All Copenhagen Boots \$184.95



BAFFIN

NEW

MEN'S BAFFIN WESTERN

Inspired by the oldest known exploration instrument, WESTERN will guide you as you brave the elements confidently in every hemisphere. Rugged but stylish, each boot in this high-performance collection is built for comfort. Whether you are exploring the Halifax Waterfront or navigating the mountain ranges of the Dolomites, WESTERN will quickly become essential for any explorer. You'll be lost without them. For diverse environments with both wet and icy conditions.

Black	
14-1895P7	14-1903P11
14-1897P8	14-1904P12
14-1899P9	14-1905P13
14-1901P10	14-1906P14
Brown	
14-1908P7	14-1916P11
14-1910P8	14-1917P12
14-1912P9	14-1918P13
14-1914P10	14-1919P14

All Western Boots \$199.95



BAFFIN

NEW



BAFFIN

NEW

MEN'S BAFFIN EASTERN

Inspired by the oldest known exploration instrument, EASTERN will guide you as you brave the elements confidently in every hemisphere. Rugged but stylish, each boot in this high-performance collection is built for comfort. Whether you are exploring the Halifax Waterfront or navigating the mountain ranges of the Dolomites, EASTERN will quickly become essential for any explorer. You'll be lost without them.

Black		Brown	
14-1792P7	14-1800P11	14-1804P7	14-1812P11
14-1794P8	14-1801P12	14-1806P8	14-1813P12
14-1796P9	14-1802P13	14-1808P9	14-1814P13
14-1798P10	14-1803P14	14-1810P10	14-1815P14

All Eastern Boots \$184.95

MEN'S BAFFIN NORTHERN

Inspired by the oldest known exploration instrument, WESTERN will guide you as you brave the elements confidently in every hemisphere. Rugged but stylish, each boot in this high-performance collection is built for comfort. Whether you are exploring the Halifax Waterfront or navigating the mountain ranges of the Dolomites, WESTERN will quickly become essential for any explorer. You'll be lost without them. For diverse environments with both wet and icy conditions.



BAFFIN

NEW



BAFFIN

NEW

Black	
14-1816P7	14-1824P11
14-1818P8	14-1825P12
14-1820P9	14-1826P13
14-1822P10	14-1827P14
Brown	
14-1828P7	14-1836P11
14-1830P8	14-1837P12
14-1832P9	14-1838P13
14-1834P10	14-1839P14

All Northern Boots \$199.95

Stand up comfort.



#585
The Leather Lined in Rustic Brown.
\$209.95

Blundstone boots stand up comfortably in all seasons, on all surfaces, on all kinds of feet.

Comfort that lasts.

Not a bad thing
to stand for.

Blundstone®

TASMANIA AUSTRALIA · 1870

Sizing & Fitting.

Kid's Blunnies

Canadian Size	8	9	10	11	12	13	1	2	3	4
Blundstone Size	7	8	9	10	11	12	13	1	2	3

Women's Size

Canadian Size	6	6.5	7	7.5	8	8.5	9	9.5	10
Blundstone Size	3	3.5	4	4.5	5	5.5	6	6.5	7

Men's Size

Canadian Size	7.5	8	8.5	9	9.5	10	10.5	11	11.5	12	13	14
Blundstone Size	6.5	7	7.5	8	8.5	9	9.5	10	10.5	11	12	13

Rule of Toe:

- For women subtract 3 sizes from your Canadian size.
- For men subtract 1 size from your Canadian size.
- For kid's subtract 1 size from your Canadian size.

It is not abnormal for there to be some initial movement in the boot, particularly in the heel area. Length is the most important element when trying them on. All Blundstone boots have reinforced toes which help keep the shape of the boot intact. The boots will never stretch in length. However, they will stretch and mold to the top of the feet, and will easily stretch in width if required. If the fit is initially tight on the top of your feet—be patient, it will stretch, or can be easily stretched by a cobbler.

All Blundstone styles aside from the Women's series, are unisex. This size conversion chart provides a simple guideline.



blundstone.ca



BLUNDSTONE 500 - STOUT BROWN

This is where it all started. The Original Chelsea in Stout Brown is shaped like your foot for instant comfort that just gets better with wear. All-season, all-surface versatility makes the Original Chelsea a favourite first boot. Blundstone fans always seem to have a well-loved pair or two of Originals kicking around. Legendary Blundstone comfort in unisex Blundstone sizing.

15-530003	15-530108
15-530013.5	15-530118.5
15-530024	15-530129
15-530034.5	15-530139.5
15-530045	15-5301410
15-530055.5	15-5301510.5
15-530066	15-5301611
15-530076.5	15-5301712
15-530087	15-5301813
15-530097.5	

All Sizes Model 500 \$239.95



BLUNDSTONE 585 - RUSTIC BROWN

Blundstone 585 Chelsea in Rustic Brown looks rustic yet refined, leather lined, feather light. Unisex Blundstone sizing. Premium leather. PLEASE NOTE: This boot features a pre-distressed leather that can vary in appearance. The boot you order may be lighter or darker than those pictured here.

15-530383	15-530488
15-530393.5	15-530498.5
15-530404	15-530509
15-530414.5	15-530519.5
15-530425	15-5305210
15-530435.5	15-5305310.5
15-530446	15-5305411
15-530456.5	15-5305512
15-530467	15-5305613
15-530477.5	

All Sizes Model 585 \$249.95



BLUNDSTONE 510 - BLACK

The Blundstone 510 Original Black Chelsea is one of our most versatile Blundstone boots. Black goes with everything! A favourite with people in uniform from pilots to posties for all-day, all-season, all-surface comfort. Unisex sizing.

15-530193	15-530298
15-530203.5	15-530308.5
15-530214	15-530319
15-530224.5	15-530329.5
15-530235	15-5303310
15-530245.5	15-5303410.5
15-530256	15-5303511
15-530266.5	15-5303612
15-530277	15-5303713
15-530287.5	

All Sizes Model 510 \$239.95



BLUNDSTONE 587 - RUSTIC BLACK

Dual-layered Blundstone 587 Leather Lined Chelsea in Rustic Black cradles feet in leather and rebuffs scrapes and nicks with a tough outer layer. All-season, all-surface comfort. Unisex sizing. Premium Leather.

15-531363	15-531468
15-531373.5	15-531478.5
15-531384	15-531489
15-531394.5	15-531499.5
15-531405	15-5315010
15-531415.5	15-5315110.5
15-531426	15-5315211
15-531436.5	15-5315312
15-531447	15-5315413
15-531457.5	

All Sizes Model 587 \$249.95



BLUNDSTONE 1306 - CHISEL TOE RUSTIC BROWN

Nothing ages more beautifully than our rustic brown Chisel Toe Chelsea boot. Over-the-ankle height provides excellent support and all-season protection from the elements. This boot can be your favourite dress boot, your knock-about go-to boot, or both. From town to trail without missing a step. All-day comfort, dry feet, no-lace ease. Chelsea boot height never goes out of style.

15-531553	15-531658
15-531563.5	15-531668.5
15-531574	15-531679
15-531584.5	15-531689.5
15-531595	15-5316910
15-531605.5	15-5317010.5
15-531616	15-5317111
15-531626.5	15-5317212
15-531637	15-5317313
15-531647.5	

All Sizes Model 1306 \$249.95



BLUNDSTONE CLASSIC #1609 - ANTIQUE BROWN

Blundstone #1609 Classic in Antique Brown combines a couple of our most popular colours and styles. #1609 Antique Brown feels and looks perfect on the first day and gets better every day as the boots fit to your feet and the leather gets gorgeous with wear. Leather-lined, pull-on, all-day comfort.

15-537053	15-537158
15-537063.5	15-537168.5
15-537074	15-537179
15-537084.5	15-537189.5
15-537095	15-5371910
15-537105.5	15-5372010.5
15-537116	15-5372111
15-537126.5	15-5372212
15-537137	15-5372313
15-537147.5	

All Sizes Model 1609 \$264.95



BLUNDSTONE GREENPATCH CSA

Blundstone CSA Greenpatch checks all the safety boxes so you can focus on the job at hand. Blundstone steel toe CSA safety and dry all-day comfort, even on concrete. Flexible, comfortable and pull-on, kick-off easy to keep mud and debris off car mats, indoor carpets and new floors. Protection from electrical, chemical and mechanical dangers. Unisex Blundstone sizing.

Black - Model 163

15-530574	15-530668.5
15-530584.5	15-530679
15-530595	15-530689.5
15-530605.5	15-5306910
15-530616	15-5307010.5
15-530626.5	15-5307111
15-530637	15-5307212
15-530647.5	15-5307313
15-530658		

All Sizes Model 163 \$239.95

Crazy Horse Brown - Model 164

15-530744	15-530838.5
15-530754.5	15-530849
15-530765	15-530859.5
15-530775.5	15-5308610
15-530786	15-5308710.5
15-530796.5	15-5308811
15-530807	15-5308912
15-530817.5	15-5309013
15-530828		

All Sizes Model 164 \$239.95

Stout Brown - Model 162

15-532224	15-532318.5
15-532234.5	15-532329
15-532245	15-532339.5
15-532255.5	15-5323410
15-532266	15-5323510.5
15-532276.5	15-5323611
15-532287	15-5323712
15-532297.5	15-5323813
15-532308		

All Sizes Model 162 \$239.95



BLUNDSTONE GREENPATCH CSA RUBBER TOE CAP

Jobs like tiling, trim, landscaping and concrete work seem to chew through work boot toes, a death by a thousand cuts, scrapes and dings. Rubber toe caps just make sense. Blundstone CSA Greenpatch Rubber Toe Cap boots combine legendary Blundstone comfort with even longer wear than before. Multiple safety features that meet CSA requirements keep feet safe. Chelsea height over-the-ankle protection. Dry, lightweight all-day comfort even on concrete. As always—no lace no trip.

Stout Brown - Model 167

15-534764.5	15-534859
15-534775	15-534869.5
15-534785.5	15-5348710
15-534796	15-5348810.5
15-534806.5	15-5348911
15-534817	15-5349012
15-534827.5	15-5349113
15-534838		
15-534848.5		

All Sizes Model 167 \$249.95

Black - Model 168

15-534924	15-535018.5
15-534934.5	15-535029
15-534945	15-535039.5
15-534955.5	15-5350410
15-534966	15-5350510.5
15-534976.5	15-5350611
15-534987	15-5350712
15-534997.5	15-5350813
15-535008		

All Sizes Model 168 \$249.95

Crazy Horse Brown - Model 169

15-535094	15-535188.5
15-535104.5	15-535199
15-535115	15-535209.5
15-535125.5	15-5352110
15-535136	15-5352210.5
15-535146.5	15-5352311
15-535157	15-5352412
15-535167.5	15-5352513
15-535178		

All Sizes Model 169 \$249.95





BLUNDSTONE #165 MET GUARD - BLACK

Our Blundstone Met Guard steel toe work boot is the ultimate in safety boots. Designed for comfort, clever met guards remain soft and flexible until point of impact. Leather-covered elastic gussets protect from side incursions. Bullet-proof Kevlar stitching resists impact and abrasion damage. For ultimate safety, don't stand for less. CSA approved.

15-537874	15-537968.5
15-537884.5	15-537979
15-537895	15-537989.5
15-537905.5	15-5379910
15-537916	15-5380010.5
15-537926.5	15-5380111
15-537937	15-5380212
15-537947.5	15-5380313
15-537958	

All Sizes Model 165 \$289.95



BLUNDSTONE #180 - WAXY RUSTIC BROWN

Introducing Blundstone #180 Work & Safety in New Waxy Rustic Brown. Packed with safety yet remarkably light on the foot, saving energy and reducing fatigue. One-finger pull-on, easy kick-off, to save time and limit debris spread. Fewer seams, fewer stitch holes to leak for dry, all-day, all-weather comfort. And underpinning it all, Blundstone patented Shock Protection System (SPS) disperses shock at heel strike and reduces skeletal stress absorbing up to 90% of the impact as you walk. Blundstone Work & Safety in Waxy Rustic Brown just plain works.

15-538784	15-538878.5
15-538794.5	15-538889
15-538805	15-538899.5
15-538815.5	15-5389010
15-538826	15-5389110.5
15-538836.5	15-5389211
15-538847	15-5389312
15-538857.5	15-5389413
15-538868	

All Sizes Model 180 \$239.95



BLUNDSTONE #181 - WAXY RUSTIC BLACK

New Blundstone #181 Work & Safety in Waxy Rustic Black meets most company uniform colour standards, even if the standard is blue jeans. The waxy finish protects the leather, packing more days into each boot. The patented Blundstone SPS (Shock Protection System) disperses shock at heel strike and reduces skeletal stress absorbing up to 90% of the impact as you walk. Seams over the instep, a key source of irritation, are avoided along with many potentially leaky stitch holes. Lightweight, one-finger easy, all-day comfort. Oh, we could wax on!

15-538974	15-539068.5
15-538984.5	15-539079
15-538995	15-539089.5
15-539005.5	15-5390910
15-539016	15-5391010.5
15-539026.5	15-5391111
15-539037	15-5391212
15-539047.5	15-5391313
15-539058	

All Sizes Model 181 \$239.95



BLUNDSTONE XFR #960 - WHEAT

Blundstone CSA-Approved 960 Work & Safety XFR in Wheat stands on a thicker, solid rubber lug sole for safe, long-wearing, comfort and stability. This unisex Blundstone Work and Safety boot has Comfort Arch footbeds reduce stress on bones and joints, cushioning heel-strike impact by up to 90%. Tough-as-nails rubber toe caps protect the boot itself and extend service life. Step up to comfort and safety that won't let you down.

15-540864	15-540958.5
15-540874.5	15-540969
15-540885	15-540979.5
15-540895.5	15-5409810
15-540906	15-5409910.5
15-540916.5	15-5410011
15-540927	15-5410112
15-540937.5	15-5410213
15-540948	

All Sizes Model 960 \$259.95



BLUNDSTONE XFR #962 - RUSTIC BROWN

Blundstone XFR safety boots stand on a thicker, grippier, solid rubber lug sole for safe, long-wearing, all-season comfort and stability. Comfort Arch footbeds help to reduce stress on bones and joints, cushioning heel-strike impact by up to 90%. Steel toe boots with rubber toe caps protect the boot itself and extending service life. Pull-on work boots that won't let you down. Chelsea boot height. The most comfortable work boot.

15-541034	15-541128.5
15-541044.5	15-541139
15-541055	15-541149.5
15-541065.5	15-5411510
15-541076	15-5411610.5
15-541086.5	15-5411711
15-541097	15-5411812
15-541107.5	15-5411913
15-541118	

All Sizes Model 962 \$259.95



BLUNDSTONE XFR #968 - BLACK

These pull on work boots stand on a thicker, grippier, solid rubber lug sole for safe, long-wearing, all-season comfort and stability. Comfort Arch footbeds to reduce stress on bones and joints, cushioning heel-strike impact by up to 90%. Tough-as-nails Blundstone steel toe boots with rubber toe caps to protect the boot itself and extend service life. Step up to comfort and safety that won't let you down.

15-541204	15-541298.5
15-541214.5	15-541309
15-541225	15-541319.5
15-541235.5	15-5413210
15-541246	15-5413310.5
15-541256.5	15-5413411
15-541267	15-5413512
15-541277.5	15-5413613
15-541288	

All Sizes Model 968 \$259.95

Blundstone

FOOTWEAR



BLUNDSTONE DRESS #068 - BLACK

Blundstone #068 Chelsea Black is a versatile all-weather boot crafted for dry, all-day comfort. A thinner sole profile gives 068 Chelsea a leg up for people who require black footwear at work. We hear that pilots love this boot for its sensitive "foot-feel" on flight foot controls. Chelsea boot height adds excellent support and all-season protection from the elements.

15-531743	15-531848
15-531753.5	15-531858.5
15-531764	15-531869
15-531774.5	15-531879.5
15-531785	15-5318810
15-531795.5	15-5318910.5
15-531806	15-5319011
15-531816.5	15-5319112
15-531827	15-5319213
15-531837.5	

All Sizes Model 068 \$249.95



BLUNDSTONE DRESS #1308 - RUSTIC BLACK

Our rustic black leather Dress Chelsea is black, relaxed. Easy to care for, easy on the eyes and crafted for long wear. #1308 Dress is Chelsea boot height for excellent support and all-season protection from the elements. All-day comfort, dry feet, no-lace ease in an enduring style for town and trail.

15-535263	15-535368
15-535273.5	15-535378.5
15-535284	15-535389
15-535294.5	15-535399.5
15-535305	15-5354010
15-535315.5	15-5354110.5
15-535326	15-5354211
15-535336.5	15-5354312
15-535347	15-5354413
15-535357.5	

All Sizes Model 1308 \$249.95



BLUNDSTONE 1469 - LEATHER LINED STEEL GREY

Here's the comfort of our popular Leather Lined Chelsea forged in riveting Steel Grey leather. Bold, strong, built to last. Excellent aging characteristics. All-season comfort on all surfaces.

15-532843	15-532948
15-532853.5	15-532958.5
15-532864	15-532969
15-532874.5	15-532979.5
15-532885	15-5329810
15-532895.5	15-5329910.5
15-532906	15-5330011
15-532916.5	15-5330112
15-532927	15-5330213
15-532937.5	

All Sizes Model 1469 \$264.95



BLUNDSTONE WOMENS #1351 - RUSTIC BROWN

Our rustic brown leather seems to fit every style of Blundstone Chelsea boot, but none better than The Women's Series. 1351 Hi-Top is Chelsea-boot height, slightly higher than our other series. A soft, comfortable, laid-back look and feel, with a higher cut and classic broguing. Town and country ready! All-season, too!

15-533052	15-533125.5
15-533062.5	15-533136
15-533073	15-533146.5
15-533083.5	15-533157
15-533094	15-533167.5
15-533104.5	15-533178
15-533115	

All Sizes Model 1351 \$264.95



BLUNDSTONE WOMENS #1448 - BLACK

Blundstone 1448 Original Women's Hi Top Black Chelsea is cut slightly higher and dressed up with a touch of decorative broguing. Crafted for a woman's foot, with additional ankle support and coverage against the elements. Total all-season, bring-it-on comfort for town and country.

15-533182	15-533255.5
15-533192.5	15-533266
15-533203	15-533276.5
15-533213.5	15-533287
15-533224	15-533297.5
15-533234.5	15-533308
15-533245	

All Sizes Model 1448 \$264.95





KIDS BLUNDSTONE 531 - BLACK

Blundstone 531 Kids Chelsea in Black gives kids pull-on, kick-off freedom. Blundstone unisex sizing, comfort and long wear make these a favourite for mom and dad, too! Removable footbeds for months more wear.

15-537447	15-5374912
15-537458	15-5375013
15-537469	15-537511
15-5374710	15-537522
15-5374811	15-537533

All Kids Sizes Model 531 \$144.95



KIDS BLUNDSTONE 565 - RUSTIC BROWN

Blundstone 565 Kid's Rustic Brown is Blundstone comfort and leather that ages beautifully. It's the DIY boot every kid loves. Look Ma, no laces! Removable footbeds for months more wear. Unisex sizing.

15-532067	15-5311112
15-532078	15-5311213
15-532089	15-531131
15-5310910	15-531142
15-5311011	15-531153

All Kids Sizes Model 565 \$144.95



KIDS BLUNDSTONE 1413 - STOUT BROWN

Blundstone 1413 Kids Chelsea in Brown with Striped Elastic is colourful fun and Blundstone comfort for little feet. No-lace freedom gives kids footwear independence. Moms, dads, and teachers, too. Removable insoles for months more wear.

15-537547	15-5375912
15-537558	15-5376013
15-537569	15-537611
15-5375710	15-537622
15-5375811	15-537633

All Kids Sizes Model 1413 \$144.95



BLUNDSTONE POLISHING PAD

Blundstone boots, like all leather, benefit from regular TLC and will pay you back with longer service life. Blundstone Polish Pad Oily Waxy Conditioner shines, conditions and protects your boots from drying out. Slips in a pocket so you can condition anywhere, anytime. For use on leather boots. Do not use on suede or nubuck.

15-5345614.95



BLUNDSTONE RENOVATING CREAM

Protect your investment and help your boots age beautifully with Blundstone Renovating Cream. Nourishes and conditions leather for longer boot life. Grab a few—the perfect gift for any Blundstone fan. Specially formulated for all Blundstone leathers. •Black for Black leathers.

- Brown for Stout Brown leathers.
- Cherry for Shiraz and Redwood.
- Rustic for Rustic Black and Rustic Brown

15-53452Black.....	14.95
15-53453Brown.....	14.95
15-53454Rustic.....	14.95
15-53455Cherry.....	14.95



BLUNDSTONE REPLACEMENT INSOLES

Enjoy additional cushioning and support with the comfort of Blundstone XRD Footbeds. Easy to insert and remove. All-day arch support. Polyurethane midsole adds comfort. XRD in the heel strike zone dissipates heel strike shock. Also handy to firm up the fit as your Blundstone boots wear in.

15-532162/3	15-531198/9
15-532174/5	15-5312010/11
15-532186/7	15-5312112/13

All Sizes \$19.95



BLUNDSTONE WATERPROOF SPRAY

Suitable for use on all kinds of footwear, including nubuck, suede and all leathers.

15-5345724.95



MENS BAFFIN IMPACT

The Baffin Impact Winter boot has been tested at both the North and South Poles, and is ready to get you through extreme elements in comfort. Rugged, lightweight, and exceedingly warm. 14" height with extendable built-in gaiter gives complete coverage, and seals out snow; 8-layer inner Baffin liner with Thermaplus provides comfort, warmth and unparalleled moisture-transfer; reflective highlights provide visibility; power buckles make for easy on- off; waterproof, and comfort-rated to -100C/-148F.

14-592M7	14-597M12
14-593M8	14-598M13
14-594M9	14-599M14
14-595M10	14-600M15
14-596M11	

All Sizes \$234.95



MENS BAFFIN EIGER

Removable 8-layer liner with Thermaplus to insulate and wick moisture; Diamond-Lite cordura upper; quick-strapping for easy on-off and precise fit; built-in gaiter on top seals out the elements; premium Polar Rubber outsole for exceptional traction; reflective highlights for nighttime visibility; removable waffle and air-bubble insoles underfoot.

14-2657M7	14-2662M12
14-2658M8	14-2663M13
14-2659M9	14-2664M14
14-2660M10	14-2665M15
14-2661M11	

All Sizes \$239.95



BAFFIN SNOW MONSTER

Rated for adventurous pursuits in extreme cold temperatures. Polar Proven in some of the world's harshest climates, SNOW MONSTER is not only technically superior, but also lightweight and flexible. Recommended during moderate levels of activity, offering everything you need in a performance winter footwear companion. Waterproof Level. Snowshoe Compatible. Slip Resistant.

14-1848M7	14-1852M11
14-1849M8	14-1853M12
14-1850M9	14-1854M13
14-1851M10	14-1855M14

All Mens Snow Monster \$244.95



MENS BAFFIN APEX

Seam-sealed to keep you dry, with durable Timberwolf leather uppers and quick-lacing for precise fit; 8-layer Thermaplus removable liners tirelessly insulate and wick moisture for all-day performance; comfort-rated to -100C/-148F; high-traction integrated Arctic Flex base.

14-5524M7	14-5529M12
14-5525M8	14-5530M13
14-5526M9	14-5531M14
14-5527M10	14-5532M15
14-5528M11	

All Apex Boots \$279.95



MENS BAFFIN SUMMIT

SUMMIT represents an evolution of winter footwear – where comfort meets agility without compromising style or protection. SUMMIT protects in both frozen and snow-covered terrains, offering snowshoe compatibility and slip-resistance during moderate levels of activity.

14-1840M7	14-1844M11
14-1841M8	14-1845M12
14-1842M9	14-1846M13
14-1843M10	14-1847M14

All Summit Boots \$229.95



MENS BAFFIN YOHO

YOHO represents an evolution of winter footwear where comfort meets agility without compromising style or protection. YOHO protects in both frozen and snow-covered terrains, offering snowshoe compatibility and slip-resistance during moderate levels of activity.

14-3386M7	14-3390M11
14-3387M8	14-3391M12
14-3388M9	14-3392M13
14-3389M10	14-3393M14

All Yoho Boots \$209.95



MENS ACTON NORWAY 2.0 BOOT

Height : 12". 600 denier nylon and waterproof synthetic leather upper. H2O Seal process sealed seams at vamp area. Hook and loop boot. Lace adjustment at cuff with barrel lock closure system. High visibility reflective inserts. Very insulating and comfortable removable triple density insulation liner. Waterproof, extremely lightweight, flexible and insulating EVA shell with an integrated heel-kick. Natural rubber, slip resistant outsole.

15-3454M7	15-3458M11
15-3455M8	15-3459M12
15-3456M9	15-3460M13
15-3457M10	15-3461M14

All Acton Norway 2.0 Boots \$179.95



MENS ACTON DENMARK BOOT

Nylon and waterproof synthetic leather upper. H2O Seal process sealed seams at vamp area. Lace adjustment at cuff with barrel lock closure system. High visibility reflective inserts. Very insulating and comfortable removable triple density insulation liner. Waterproof, extremely lightweight, flexible and insulating EVA shell with an integrated heel-kick. Natural rubber outsole, slip resistant on frosted surfaces.

15-3462M7	15-3466M11
15-3463M8	15-3467M12
15-3464M9	15-3468M13
15-3465M10	15-3469M14

All Acton Denmark Boots \$189.95



MENS ACTON YUKON BOOT

Waterproof synthetic leather and hydrophobic ripstop nylon. H2O Seal process sealed seams at vamp area. High visibility reflective inserts. Removable triple density insulation liner with stabilizer arch. Removable insulating felt insole. Waterproof, extremely lightweight, flexible and insulating EVA shell. Adherent and stable synthetic rubber outsole.

15-3379M7	15-3383M11
15-3380M8	15-3384M12
15-3381M9	15-3385M13
15-3382M10	15-3386M14

All Acton Yukon Boots \$149.95

Winter Snow Boots



ACTON LADIES SWEDEN BOOT

Height : 12". Nylon and waterproof synthetic leather upper. H2O Seal process sealed seams at vamp area. Hook and loop boot. Lace adjustment at cuff with barrel lock closure system. High visibility reflective inserts. Very insulating and comfortable removable triple density insulation liner. Waterproof, extremely lightweight, flexible and insulating EVA shell with an integrated heel-kick. Natural rubber, slip resistant outsole.

15-3470M6	15-3473M9
15-3471M7	15-3474M10
15-3472M8	15-3475M11

All Acton Sweden Boots \$159.95



ACTON LADIES CAROLYN BOOT

Waterproof synthetic leather and hydrophobic nylon. Sealed seams at vamp area. Laced up boot with barrel lock closure system. Extra bootlace included. Removable triple density insulation liner. Removable insulating felt insole. Waterproof, lightweight and insulating EVA shell. Adherent and synthetic rubber outsole.

15-3372M5	15-3376M9
15-3373M6	15-3377M10
15-3374M7	15-3378M11
15-3375M8	

All Acton Carolyn Boots \$129.95



ACTON LADIES EMMA BOOT

Waterproof synthetic leather and hydrophobic nylon. H2O Seal process sealed seams at vamp area. Removable triple density insulation liner with stabilizer arch. Removable insulating felt insole. Waterproof, extremely lightweight, flexible and insulating EVA shell. Adherent and stable synthetic rubber outsole.

15-3447M5	15-3451M9
15-3448M6	15-3452M10
15-3449M7	15-3453M11
15-3450M8	

All Acton Emma Boots \$129.95

FOOTWEAR



WOMENS CHLOE

TPR rubber with integrated arch support. MidSole: Proprietary cold resistant EVA compound. Base: TPR rubber with integrated arch support. Liner: 7-layer inner boot system with Thermaplush.

Taupe		Charcoal		Black	
14-2879P6	14-2882P9	14-2890P6	14-2893P9	14-2867P6	14-2870P9
14-2880P7	14-2883P10	14-2891P7	14-2894P10	14-2868P7	14-2871P10
14-2881P8	14-2884P11	14-2892P8	14-2895P11	14-2869P8	14-2872P11
All Sizes \$184.95		All Sizes \$184.95		All Sizes \$184.95	



LADIES BAFFIN IMPACT

Baffin's Impact Winter boots have been tested at both the North and South Poles, and are ready to get you through the elements in comfort. Rugged, lightweight, and exceedingly warm; wearing a pair is like walking on a cloud. 14" height with extendable built-in gaiter gives complete coverage, and seals out snow; 8-layer inner Baffin liner with Thermaplush provides comfort, warmth and unparalleled moisture-transfer; reflective highlights provide visibility; power buckles make for easy on-off; waterproof, and comfort-rated to -100C/- 148F.

WOMENS SNOGOOSE

DRIFT SERIES. Full function lacing for a great fit through the instep. Lightweight Avalanche low base with integral under arch support system. Locking snow cuff for deep powder days.

Black		Charcoal	
14-5793P6	14-5796P9	14-5833P6	14-5836P9
14-5794P7	14-5797P10	14-5834P7	14-5837P10
14-5795P8	14-5798P11	14-5835P8	14-5838P11
All Sizes \$174.95		All Sizes \$174.95	

14-601M6	14-604M9
14-602M7	14-605M10
14-603M8	14-606M11
All Sizes \$224.95	



BAFFIN LADIES FLARE

FLARE represents an evolution of winter footwear – where comfort meets agility without compromising style or protection. FLARE protects in both frozen and snow-covered terrains, offering snowshoe compatibility and slip-resistance during moderate levels of activity. For experiences on snow covered frozen terrain.

14-1887P5	14-1891P9
14-1888P6	14-1892P10
14-1889P7	14-1893P11
14-1890P8	

All Ladies Flare \$219.95



LADIES BAFFIN JESS

Temperature Rating: From -5°C to -50°C. Liner: Body-heat mouldable, removable liner. Featuring B-Tek Lite. Base: Superlite Shell, AirGrip Midsole and Outsole with Polar Rubber contact points. Waterproof breathable upper materials. Speed-lacing. Fashionable styling.

14-716P6	14-719P9
14-717P7	14-720P10
14-718P8	14-721P11

All Sizes \$219.95



LADIES BAFFIN SAGE

SAGE represents an evolution of winter footwear – where comfort meets agility without compromising style or protection. SAGE protects in both frozen and snow-covered terrains, offering snowshoe compatibility and slip-resistance during moderate levels of activity.

14-167P5	14-171P9
14-168P6	14-172P10
14-169P7	14-173P11
14-170P8	

All Sizes \$209.95



BAFFIN LADIES ELDORA

While function precedes fashion, Baffin is committed to providing footwear that looks great too. ELDORA keeps you warm, dry and comfortable from early Fall through late Spring. These boots are designed for you to wear from your house out to dinner and from the streets into your office. ELDORA merges protection with pride. For diverse environments with both wet and icy conditions.

14-1873P6	14-1876P9
14-1874P7	14-1877P10
14-1875P8	14-1878P11

All Ladies Eldora \$214.95



LADIES BAFFIN ZONE

Breathable soft shell fabric. Ultra light weight construction. Waterproof membrane. High traction sole.

RATING -20°C/-4°F

Black

14-2924P7
14-2925P8
14-2926P9
14-2927P10

Brown

14-2928P11	14-2940P7	14-2944P11
14-2929P12	14-2941P8	14-2945P12
14-2930P13	14-2942P9	14-2946P13
14-2931P14	14-2943P10	14-2947P14

All Sizes \$199.95



LADIES BAFFIN HIKE

Breathable soft shell fabric. Ultra light weight construction. Waterproof membrane. High traction sole.
 RATING -20°C/-4°F

Charcoal		Black/Sangria	
14-2752P6	14-2755P9	14-1880P6	14-1883P9
14-2753P7	14-2756P10	14-1881P7	14-1884P10
14-2754P8	14-2757P11	14-1882P8	14-1885P11

All Sizes \$184.95

KIDS ACTON BEAR BOOT

Waterproof synthetic leather and hydrophobic ripstop nylon upper. H2O Seal process sealed seams at vamp area. Two hook and loop or laced up boot with barrel lock closure system. High visibility reflective inserts. Removable triple density insulation liner with stabilizer arch. Removable insulating felt insole trapping moisture. Waterproof, extremely lightweight, flexible and insulating EVA shell. Adherent and stable synthetic rubber outsole.

15-3345M10	15-3350M2
15-3346M11	15-3351M3
15-3347M12	15-3352M4
15-3348M13	15-3353M5
15-3349M1	15-3354M6

All Acton Bear Boots \$109.95



KIDS ACTON KIDDY BOOT

Waterproof synthetic leather and hydrophobic ripstop nylon. Two hook and loop closures. High visibility reflective inserts. Wide opening easing donning. Removable and supple insulating felt liner. Removable insulating felt insole trapping moisture. Waterproof, extremely lightweight, flexible and insulating EVA shell. Waterproof, non-compacting lightweight, anti-skidding and nonmarking synthetic rubber outsole.

Black		Pink	
15-3387M4	15-3391M8	15-3394M4	15-3398M8
15-3388M5	15-3392M9	15-3395M5	15-3399M9
15-3389M6	15-3393M10	15-3396M6	15-3400M10
15-3390M7		15-3397M7	

All Acton Kiddy Boots \$89.95



KIDS ACTON HIP HOP BOOT

Waterproof synthetic leather and hydrophobic ripstop nylon upper. H2O Seal process sealed seams at vamp area. Two hook and loop or laced up boot with barrel lock closure system. High visibility reflective inserts. Removable triple density insulation liner with stabilizer arch (Sizes 13 to 8). Removable insulating felt insole trapping moisture. Waterproof, extremely lightweight, flexible and insulating EVA shell. Adherent and stable synthetic rubber outsole.

15-3307M10	15-3313M3
15-3308M11	15-3314M4
15-3309M12	15-3315M5
15-3310M13	15-3316M6
15-3311M1	15-3317M7
15-3312M2	15-3318M8

All Acton Hip Hop Boots \$109.95

NEW



ACTON
KIDS



KIDS ACTON TINY BOOT

Hydrophobic nylon upper. Hook and loop closure. High visibility reflective inserts. Wide opening easing donning. Fleece liner. Waterproof and flexible expanded rubber shell. Non-compacting, lightweight and nonmarking expanded rubber outsole.

Grey/Green

15-3401M4
15-3402M5
15-3403M6
15-3404M7

Black/Pink

15-3405M8
15-3406M9
15-3407M10
15-3408M4
15-3409M5
15-3410M6
15-3411M7
15-3412M8
15-3413M9
15-3414M10

All Acton Tiny Boots \$79.95

SHOP 24/7 FROM THE COMFORT OF YOUR OWN HOME

- Up to date Pricing
- New Products
- Stock Status
- Additional product info
- And more



www.mercersmarine.com

NEW



ACTON
KIDS

NEW



ACTON
KIDS

NEW



ACTON
KIDS

ACTON KIDS CORTINA BOOT

Waterproof synthetic leather and hydrophobic ripstop nylon upper. H2O Seal process sealed seams at vamp area. Two hook and loop or laced up boot with barrel lock closure system. High visibility reflective inserts. Removable triple density insulation liner with stabilizer arch (sizes 13 to 7). Removable insulating felt insole trapping moisture. Waterproof, extremely lightweight, flexible and insulating EVA shell. Adherent and stable synthetic rubber outsole.

15-3433M10	15-3439M3
15-3434M11	15-3440M4
15-3435M12	15-3441M5
15-3436M13	15-3442M6
15-3437M1	15-3446M7
15-3438M2		

All Acton Cortina Boots \$109.95

ACTON KIDS ACTIVE BOOT

Waterproof synthetic leather and hydrophobic ripstop nylon. Removable comfortable insole made of memory foam and covered with knit. Laced up boot with barrel lock closure system. Synthetic sheep wool lining. 200 g insulation surrounding the foot. Waterproof and flexible synthetic rubber shell. Adherent and stable synthetic rubber outsole.

15-3415M11	15-3420M3
15-3416M12	15-3421M4
15-3417M13	15-3422M5
15-3418M1	15-3423M6
15-3419M2		

All Acton Active Boots \$84.95

ACTON KIDS SMILE BOOT

Waterproof synthetic leather and hydrophobic ripstop nylon. Removable comfortable insole made of memory foam and covered with knit. Laced up boot with barrel lock closure system. Synthetic sheep wool lining. 200g insulation surrounding the foot. Waterproof and flexible synthetic rubber shell. Adherent and stable synthetic rubber outsole.

15-3424M11	15-3429M3
15-3425M12	15-3430M4
15-3426M13	15-3431M5
15-3427M1	15-3432M6
15-3428M2		

All Acton Smile Boots \$84.95



YOUTH BAFFIN EIGER

Lightweight, warm, waterproof and durable, these are expedition-worthy boots that are perfect for snowmobiling, ice fishing, sledding, and simply playing in the snow all day. High-quality Pro-Tech microfiber upper; grippy Arctic Flex rubber sole; comfort-rated to -60C; built-in gaiter on top seals out snow; removable 7-layer liner with Thermaplus provides insulation and wicks moisture; dual straps give precise fit and easy on-off; reflective highlights for visibility & style.

Youth

14-2646M11	14-2649M1
14-2647M12	14-2650M2
14-2648M13	

All Sizes 11-2 \$124.95

Junior

14-2651M3	14-2654M6
14-2652M4	14-2655M7
14-2653M5	14-2656M8

All Sizes 3-8 \$129.95



YOUTH BAFFIN MUSTANG

Funky styling with a Velcro strap for convenient fastening with locking snow collar. PR rubber outsole. MidSole: Base: 2 stage BXT base. Insole: Base and liner provide support. Upper: Double weave 900 denier nylon.

Youth

14-2840M11	14-2843M1
14-2841M12	14-2844M2
14-2842M13	

All Sizes 11-2 \$104.95

Junior

14-2845M3	14-2848M6
14-2846M4	14-2849M7
14-2847M5	14-2850M8

All Sizes 3-8 \$109.95



Youth - Navy

14-2851M11	14-2854M1
14-2852M12	14-2855M2
14-2853M13	

All Sizes 11-2 \$104.95

Junior - Navy

14-2845M3	14-2848M6
14-2846M4	14-2849M7
14-2847M5	14-2850M8

All Sizes 3-8 \$109.95



YOUTH BAFFIN YOUNG SNOGOOSE

The Snogoose kids boot from Baffin is ready for all the energy junior can bring this winter, and then some. Epic outings will be sought after, and enjoyed. Lightweight, warm, durable, waterproof, and loaded with features: expanded toe box; built-in gaiter to seal out snow; grippy TPR rubber outsole; multi-layer removable liner to transport moisture; integrated arch support; comfort-rated to -60C/-76F.

Youth (Black/Plum)

14-5799M11	14-5802M1
14-5800M12	14-5803M2
14-5801M13	

Youth (Black/Hyper Berry/Pink)

14-3067M11	14-3070M1
14-3068M12	14-3071M2
14-3069M13	

Juniors (Black/Plum)

14-5804M3	14-5807M6
14-5805M4	14-5808M7
14-5806M5	14-5809M8

Juniors (Black/Hyper Berry/Pink)

14-3072M3	14-3075M6
14-3073M4	14-3076M7
14-3074M5	14-3077M8

All Sizes 11-2 \$109.95 // All Sizes 11-2 \$114.95



YOUTH BAFFIN AVERY

AVERY is equipped with the same comfort, warmth and quality as any of our adult boots. These lightweight, flexible boots allow for kids to take on the winter in any weather. Whether it's recess, the park or in your own backyard, your kids will have the same Baffin confidence you do. For experiences on snow covered frozen terrain.

Youth

14-3628M11	14-3631M1
14-3629M12	14-3632M2
14-3630M13	

All Sizes 11-2 \$109.95

Junior

14-3633M3	14-3635M5
14-3634M4	14-3636M6

All Sizes 3-8 \$119.95



-60°C

BAFFIN TRAPPERS

Performance rubber boot with "ADVANCE COLD WEATHER" inner boot system. 100% waterproof, premium grade "BOB" sole.

14-1050M7	14-1054M11
14-1051M8	14-1055M12
14-1052M9	14-1056M13
14-1053M10	

All Sizes \$124.95



-100°C

BAFFIN TITAN - REGULAR TOE

Front shin protection with 1" snow cuff. Full molded waterproof boot. Aggressive, long wearing outsole.

14-5588M7	14-5592M11
14-5589M8	14-5593M12
14-5590M9	14-5594M13
14-5591M10	14-5595M14

All Sizes \$184.95



ACTON ADVENTURE

Very lightweight, insulating and waterproof EVA upper. Lace adjustment at cuff with barrel lock closure system. Very insulating and comfortable removable triple density insulation liner with Lock-Fit Ankle Support System. Natural rubber 4Grip outsole, slip resisting on frosted surfaces. Heel kick to get out of the boot easily. 90° heel angle.

A3942-15	
15-2336M6	15-2341M11
15-2337M7	15-2342M12
15-2338M8	15-2343M13
15-2339M9	15-2344M14
15-2340M10	

All Acton Adventure Boots \$149.95



-40°C

BAFFIN HUNTERS - MENS, CHILDRENS, YOUTH)

A really good boot at a very reasonable price. 100% waterproof with a 3- component removable liner. "BAR" sole and snow collar. Dark green, regular toe

Mens

14-039M6	14-043M10
14-040M7	14-044M11
14-041M8	14-045M12
14-042M9	14-046M13

All Mens Sizes \$89.95

Childrens & Youth

14-058M8	14-064M1
14-059M9	14-065M2
14-060M10	14-055M3
14-061M11	14-056M4
14-062M12	14-057M5
14-063M13	

Sizes 8-2 \$66.95 // Sizes 3-5 \$78.95



-30°C

WOMEN'S "STORM" & SAFETY STORM

12" waterproof boots with 6mm, 3-component removable liner. High quality "TPR" construction. Popular in fish plants. Nylon tie-top.

Regular Toe

14-066M5	14-069M8
14-067M6	14-070M9
14-068M7	14-071M10

All Regular Toe Sizes \$69.95

Safety Toe

14-206M5	14-209M8
14-207M6	14-210M9
14-208M7	14-211M10

All Safety Toe Sizes \$74.95



**Shop or Browse
Online 24/7
at
mercersmarine.com**





ACTON PRAIRIE 13 1/2"

Prairie boots have set the standard for comfort and warmth for years. Hand crafted natural rubber. 100% waterproof. Soft and flexible with removable triple density insulation liner and nylon tie top. Enlarge calf for better fit. Model A3670-15

Green

14-025M3	14-031M9
14-026M4	14-032M10
14-027M5	14-033M11
14-028M6	14-034M12
14-029M7	14-035M13
14-030M8	

All Sizes (Green) \$124.95



Camo

14-093M3	14-099M9
14-094M4	14-100M10
14-095M5	14-101M11
14-096M6	14-102M12
14-097M7	14-103M13
14-098M8	

All Sizes (Camo) \$159.95

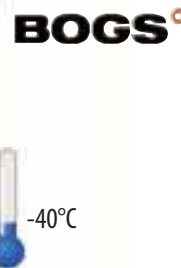

BOGS BLAZE II

100% waterproof. Durable hand-lasted rubber and a four way stretch inner bootie. Blaze Orange lining. 3M Bogs Neo-Tech +1000 grams of Thinsulate insulation. Scent combat bio-technology activates to fight odors. Bogs Max-Wick moves sweat away and keeps feet dry. Non-slip, Non-marking and self-cleaning deep lug outsole. Comforted rated to -40°C

Model 72323-973 Mossy Oak

14-85244M7	14-85248M11
14-85245M8	14-85249M12
14-85246M9	14-85250M13
14-85247M10	14-85251M14

All Bogs Blaze II Boots \$249.99



ACTON PRAIRIE REPLACEMENT LINERS

14-010M3	14-016M9
14-011M4	14-017M10
14-012M5	14-018M11
14-013M6	14-019M12
14-014M7	14-020M13
14-015M8	14-021M14

All Sizes \$38.95

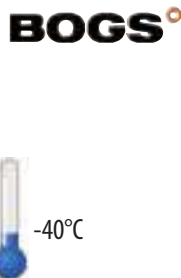

BOGS CLASSIC HIGH

100% waterproof. Durable hand-lasted rubber and a four way stretch inner bootie. Classic Mossy Oak pattern overlay. Non-slip, non-marking and self cleaning outsole. Dual density, contoured EVA insole with DuraFresh anti-odor protection. 7mm waterproof Neo-Tech insulation. Comfort rated from temperate to cold conditions.

Model 60542-973 Mossy Oak

14-31541M8	14-31545M12
14-31542M9	14-31546M13
14-31543M10	14-31547M14
14-31544M11	

All Mens Bogs Classic High \$154.99



BOGS LADIES CLASSIC HIGH CAMO

100% waterproof. Blaze orange lining. Durable hand lasted rubber with a four way stretch inner bootie. Constructed with 7mm Neo-Tech insulation. Kined with Bogs Max-Wick to keep feet dry. Durafresh bio-technology that activates to fight odors. Non-marking and self-cleaning outsole. Comfort rated to -40°C.

Model 72316-973 Mossy Oak

14-85588M6	14-85591M9
14-85589M7	14-85592M10
14-85590M8	14-85593M11

All Ladies Bogs Classic High Camo \$149.99





Rear Gusset



Rear Gusset



MUCK WETLAND BOOT

Keeps you warm, dry and protected in the muddiest and coldest of conditions. 100% waterproof. The stretch-fit top-line binding stays snug around the calf to keep warmth in and cold out, with signature Muck Boot neoprene to keep you comfortable even in extreme conditions. These premium work boots have a rubber calf-high exterior which protects against sticks, rocks and scratches, and the air mesh lining lets your feet breathe. Pull tabs for easy on and off.

Mens (WET-998K) Bark

15-80433M6	15-80438M11
15-80434M7	15-80439M12
15-80435M8	15-80440M13
15-80436M9	15-80441M14
15-80437M10	15-80442M15

All Mens Muck Wetland \$189.95

MUCK WETLAND XF BOOT

This Wetland features an adjustable gusset for a personalized calf fit. Keeps you warm, dry and protected in the muddiest and coldest of conditions. The stretch-fit top-line binding stays snug around the calf to keep warmth in and cold out, with signature Muck Boot neoprene to keep you comfortable in extreme conditions. These premium work boots have a rubber calf-high exterior which protects against sticks, rocks and scratches, and the air mesh lining lets your feet breathe. Pull on tabs for easy on and off

Mens (MWET-900) Bark

15-80836M7	15-80841M12
15-80837M8	15-80842M13
15-80838M9	15-80843M14
15-80839M10	15-80844M15
15-80840M11	

All Mens Muck Wetland XF \$209.95

MUCK MUCKMASTER XF BOOT

Fully waterproof gusset, so you can be sure you'll get the best fit. Extends up to 3-4 inches. These rugged boots are built to withstand sharp objects and provide extreme warmth, even standing all day in wet conditions.

Mens (MMXF-000) Black

15-80788M7	15-80793M12
15-80789M8	15-80794M13
15-80790M9	15-80795M14
15-80791M10	15-80796M15
15-80792M11	

All Mens Muckmaster \$229.95



MUCK "ARCTIC ICE" BOOT

100% Waterproof. Fully lined with 5mm CR Flex-Foam neoprene, 100% waterproof with exceptional comfort, flexibility, shock absorption and heat retention properties; adjusts to the contours of your foot to resist blisters and chafing. Fleece lining for additional warmth. Lightweight, cushioned EVA midsole for added comfort. Extended rubber coverage for added protection. Comfort insole. Antimicrobial footbed insert topcover with odor control and moisture management. Vibram Arctic Grip A.T for wet ice traction coupled with XS Trek Evo adding durability and improved grip on wet and dry surfaces. Pull-tab for easy on and off. Estimated height:13in. Estimated max calf circumference: 16.1in. Comfort Range: -40°C to 4°C.

Mens (AVTVA-000) Black

15-80971M7	15-80976M12
15-80972M8	15-80977M13
15-80973M9	15-80978M14
15-80974M10	15-80979M15
15-80975M11	

All Mens Muck Arctic Ice Black \$259.95

Mens (MHVA-RTE) Camo

15-80961M7	15-80966M12
15-80962M8	15-80967M13
15-80963M9	15-80968M14
15-80964M10	15-80969M15
15-80965M11	

All Mens Muck Arctic Ice Camo \$319.95



MUCK MUDDER TALL CAMO BOOT

100% Waterproof, 100% MUCKPROOF. Soft, Flexible Rubber Upper Provides Durable Protection. Dual Density Footbed with Memory Foam for Long Lasting Comfort. Anti-Microbial Footbed Insert Topcover with Odor Control and Moisture Management. Extra Toe & Heel Underlays for Additional Protection. Durable Rubber Outsole with Superior Surface Traction. Oil & Gas Resistant Outsole. SRC Rated-Slip Resistant.

Mens (MUD-MDNA) Mossy Oak

15-81035M7	15-81040M12
15-81036M8	15-81041M13
15-81037M9	15-81042M14
15-81038M10	15-81043M15
15-81039M11	

All Mens Muck Mudder Camo \$169.95



MUCK "ARCTIC PRO"

Fleece lining. Stretch-fit topline binding snugs leg to keep warmth in and cold out. 8mm CR flex-foam bootie with four-way stretch nylon, 100% waterproof, lightweight and flexible. Bob-tracker molded outsole is rugged, aggressive and durable for maximum protection and stability. Double reinforcements on the instep, heel and achilles areas. 2mm thermal foam underlay added to the instep area for additional warmth. EVA molded midsole with contoured footbed. Reinforced toe. Added toe protection with a wrap-up bumper. Height 17.56".

Comfort range, -50° C to 4°C.

ACP-998K - Bark

15-80402M6	15-80407M11
15-80403M7	15-80408M12
15-80404M8	15-80409M13
15-80405M9	15-80410M14
15-80406M10	15-80411M15

All Sizes \$199.95



ACP-MOCT - Mossy Oak Break Up

15-80422M6	15-80427M11
15-80423M7	15-80428M12
15-80424M8	15-80429M13
15-80425M9	15-80430M14
15-80426M10	15-80431M15

All Sizes \$289.95



MUCK ARCTIC SPORT TALL

Stretch-fit topline binding snugs leg to keep warmth in and cold out. 5mm CR flex-foam bootie with four-way stretch nylon, 100% waterproof, lightweight and flexible. MS-1 molded outsole is rugged, aggressive and durable for maximum protection and stability. Double reinforcements on the instep, heel and achilles areas. 2mm thermal foam underlay added to the instep area for additional warmth. EVA molded midsole with contoured footbed. Reinforced toe. Added toe protection with a wrap-up bumper.

Comfort range of -40° C to 15°C

ASP-000A - Black

15-80449M6	15-80454M11
15-80450M7	15-80455M12
15-80451M8	15-80456M13
15-80452M9	15-80457M14
15-80453M10	15-80458M15

All Sizes \$199.95



MUCK "CHORE" CSA

Our best-selling Chore Series provides dry, comfortable footwear that's built to handle the toughest of jobs. Stretch-fit topline binding snugs calf to keep warmth in and cold out. 5mm NEOPRENE bootie with four-way stretch nylon, 100% waterproof, lightweight and flexible. Durable, lightweight rubber outsole. Upper is triple reinforced in the toe area and quadruple reinforced in the heel area. Steel shank for additional arch support. Quick-clean rubber overlay. Steel toe. Height 16"

CHS-CSAA - Black

15-80748M7	15-80752M11
15-80749M8	15-80753M12
15-80750M9	15-80754M13
15-80751M10	15-80755M14

All Muck Chore Boots \$229.95



MUCK "ARCTIC PRO" CSA

Fully insulated with 8mm Neoprene. This provides the optimal warmth, comfort, and waterproofing that you expect from a Muck Boot. A fleece liner is added to keep your feet warm in down to -60 degrees. We wanted to make sure your feet were warm so we added an extra 2mm of thermal foam in the foot area. The stretch-fit topline binding is snug around the calf to keep warm air in and cold air out. The seamless construction allows for easy cleaning with the simple spray of the hose. Double reinforcement in the instep, heel and achilles area. EVA midsole cushions with every step. Height 17"

ACP-CSA - Black

15-80758M7	15-80762M11
15-80759M8	15-80763M12
15-80760M9	15-80764M13
15-80761M10	15-80765M14

All Muck Arctic Pro CSA Boots \$259.95



MUCK "MUCKSTER II"

One of our most versatile style, these boots have been updated with a new height and outsole pattern. The Muckster II Ankle is ideal for any chore or task where there is mud, slush or rain. Easy to slip-on and quick to kick-off, makes it a great leave-by-the-back-door boot. Best of all, they feature 4mm Neoprene and the traditional Muck Airmesh lining that allows for breathability. Slip them on and you will always feel dry and comfortable.

M2A-000 - Black

15-80724M7	15-80729M12
15-80725M8	15-80730M13
15-80726M9	15-80731M14
15-80727M10	15-80732M15
15-80728M11	

All Muck Muckster Boots \$119.95



Muck Boots

MUCK LADIES "ARCTIC SPORT II"

The warmest women's Muck Boot has been upgraded for improved warmth and comfort for use in some of the coldest conditions. Redesigned for durability and a better fit, the Arctic Sport II works well in the barn, on the mountains, on country roads or city streets. Upper: Extended Rubber Exterior. Insulation: 5mm of Neoprene. Lining: Warm Fleece. Midsole: Dual Density EVA with comfort insole. Outsole: Slip-Resistant Rugged.

Black - Ladies Arctic Sport II TALL

15-80490M5	15-80494M9
15-80491M6	15-80495M10
15-80492M7	15-80496M11
15-80493M8	

Black/Grey - Ladies Arctic Sport II TALL

15-80877M5	15-80881M9
15-80878M6	15-80882M10
15-80879M7	15-80883M11
15-80880M8	

Brown - Ladies Arctic Sport II TALL

15-81045M5	15-81049M9
15-81046M6	15-81050M10
15-81047M7	15-81051M11
15-81048M8	

All Muck Arctic Sport II Tall \$199.95

Black - Ladies Arctic Sport II MID

15-80518M5	15-80522M9
15-80519M6	15-80523M10
15-80520M7	15-80524M11
15-80521M8	

Black/Pink - Ladies Arctic Sport II MID

15-81028M5	15-81032M9
15-81029M6	15-81033M10
15-81030M7	15-81034M11
15-81031M8	

Black/Brown - Ladies Arctic Sport II MID

15-81053M5	15-81057M9
15-81054M6	15-81058M10
15-81055M7	15-81059M11
15-81056M8	

All Muck Arctic Sport II MID \$189.95



FOOTWEAR



MUCK LADIES "ARCTIC ICE" TALL

Featuring an 8mm neoprene bootie with fleece lining wrapped in layers of soft rubber so your feet will stay warm and dry in the most extreme conditions. The EVA midsole offers added underfoot comfort with a Vibram Arctic Grip outsole with Ictetrek for confidence on the iciest surfaces. 100% Waterproof. Boot Height 17.56"

Black/Heather - Ladies Arctic Ice TALL

15-81000M5	15-81004M9
15-81001M6	15-81005M10
15-81002M7	15-81006M11
15-81003M8	

Black/Pink - Ladies Arctic Ice TALL

15-81007M5	15-81011M9
15-81008M6	15-81012M10
15-81009M7	15-81013M11
15-81010M8	

All Muck Arctic Ice TALL \$259.95



Ladies



MUCK LADIES "ARCTIC ICE" MID

Featuring an 8mm neoprene bootie with fleece lining wrapped in layers of soft rubber so your feet will stay warm and dry in the most extreme conditions. The EVA midsole offers added underfoot comfort with a Vibram Arctic Grip outsole with Ictetrek for confidence on the iciest surfaces. 100% Waterproof. Boot Height 12.45"

Black/Heather - Ladies Arctic Ice MID

15-81014M5	15-81018M9
15-81015M6	15-81019M10
15-81016M7	15-81020M11
15-81017M8	

Black/Pink - Ladies Arctic Ice MID

15-81021M5	15-81025M9
15-81022M6	15-81026M10
15-81023M7	15-81027M11
15-81024M8	

All Muck Arctic Ice MID \$239.95



Ladies



MUCK LADIES ORIGINAL ANKLE BOOTS

100% Waterproof. Antimicrobial Footbed Insert with odor Control and Moisture Management. Full Neoprene Bootie Exposed at Sides for Added Comfort and Easy On/Off. 3D Airmesh Linings for Breathability. Molded PU Insert with Memory Foam for Superior Underfoot Comfort.

Black - Ladies Original Ankle

15-80946M5	15-80950M9
15-80947M6	15-80951M10
15-80948M7	15-80952M11
15-80949M8	

Taupe - Ladies Original Ankle

15-80939M5	15-80943M9
15-80940M6	15-80944M10
15-80941M7	15-80945M11
15-80942M8	

All Muck Original Ankle Boots \$149.95



MUCK OUTSCAPE LOW

100% Waterproof. Antimicrobial Footbed Insert. Flexible Neoprene with Abrasion Resistant Rubber Coating. Easy Slip On/Off. Lightweight Cushioning Foam Midsole. Self-Cleaning Outsole Lugs for Optimal Traction and Reliability. Rubber toe and heel for more Durability and Extended Wear. Shovel-Ready Nylon Shank for Added Underfoot Stability when Using Garden Tools. Recommend: This style features a wide fit, we recommend 1/2 size down for regular or narrow fit.

OSS-900 Brown

15-80912M7	15-80920M11
15-80914M8	15-80922M12
15-80916M9	15-80923M13
15-80918M10	15-80924M14

All Mens Muck Outscape Low 159.95



MUCK OUTSCAPE CHELSEA

100% Waterproof. Antimicrobial Footbed Insert. Flexible Neoprene with Abrasion Resistant Rubber Coating. This style features a wide fit, we recommend 1/2 size down for regular or narrow fit. Easy Slip On/Off. Lightweight Cushioning Foam Midsole. Rubber toe and heel for more Durability and Extended Wear. Shovel-Ready Nylon Shank for Added Underfoot Stability.

OSC-900 Brown

15-80980M7	15-80988M11
15-80982M8	15-80990M12
15-80984M9	15-80991M13
15-80986M10	15-80992M14

All Mens Muck Outscape Chelsea \$169.95



MUCK KIDS "RUGGED II"

The Kid's Rugged II will protect your child's feet in severe cold with the 5mm CR Flex-Foam insulation backed with a fleece lining. This lining adds extra insulation to keep cold out for kids that want to stay outside playing in the snow all day. 5mm CR Flex-Foam. Warm Fleece Lining. Extended Rubber Exterior. EVA Midsole for Added Comfort. Aggressive, Durable Outsole. Durable Rubber Exterior.

Black - Kids Rugged II

15-80644M7C	15-80651M1
15-80645M8C	15-80652M2
15-80646M9C	15-80653M3
15-80647M10C	15-80654M4
15-80648M11C	15-80855M5
15-80649M12C	15-80856M6
15-80650M13C	15-80857M7

Black/Grey - Kids Rugged II

15-79000M7C	15-79007M1
15-79001M8C	15-79008M2
15-79002M9C	15-79009M3
15-79003M10C	15-79010M4
15-79004M11C	15-79011M5
15-79005M12C	15-79012M6
15-79006M13C	15-79013M7

Black/Pink - Kids Rugged II

15-80672M7C	15-80679M1
15-80673M8C	15-80680M2
15-80674M9C	15-80681M3
15-80675M10C	15-80682M4
15-80676M11C	15-80883M5
15-80677M12C	15-80884M6
15-80678M13C	15-80885M7

Camo - Kids Rugged II

15-80700M7C	15-80707M1
15-80701M8C	15-80708M2
15-80702M9C	15-80709M3
15-80703M10C	15-80710M4
15-80704M11C	15-80711M5
15-80705M12C	15-80712M6
15-80706M13C	15-80713M7

Black/Blue - Kids Rugged II

15-81084M7C	15-81091M1
15-81085M8C	15-81092M2
15-81086M9C	15-81093M3
15-81087M10C	15-81094M4
15-81088M11C	15-81095M5
15-81089M12C	15-81096M6
15-81090M13C	15-81097M7

All Muck Kids Rugged II Boots 129.95

Grundens

NEW

GRUNDENS



NEW

GRUNDENS



Ladies

Ladies



Ladies



GRUNDENS 6" DECK BOSS BOOT

The DECK-BOSS™ collection was designed to provide anglers with comfortable performance driven footwear options that will outlast even the longest days on the water. We've prioritized a thicker insole to promote noticeable shock resistance and the Anti-odor cooling liner will ensure you leave the typical footwear stench behind. Built in razor siping helps move water out from under the shoe improving grip on wet surfaces and combined with a natural gum rubber outsole, you'll be standing upright on deck all day long.

Features

- All-Day Comfort Foot-Bed
- Asymmetrical Top-Line
- Temperature Regulating Liner
- 100% Waterproof
- Anti-odor cooling liner

GREEN - MENS

14-7543M8	14-7547M12
14-7544M9	14-7548M13
14-7545M10	14-7549M14
14-7546M11	

BROWN - MENS

14-7568M8	14-7572M12
14-7569M9	14-7573M13
14-7570M10	14-7574M14
14-7571M11	

RED - LADIES

14-7550M5	14-7554M9
14-7551M6	14-7555M10
14-7552M7	14-7556M11
14-7553M8	

BLACK - LADIES

14-7578M5	14-7582M9
14-7579M6	14-7583M10
14-7580M7	14-7584M11
14-7581M8	

BLUE - LADIES

14-7587M5	14-7591M9
14-7588M6	14-7592M10
14-7589M7	14-7593M11
14-7590M8	

All Grundens 6" Ankle Deck Boss Boots \$129.95

GRUNDENS 6" DEVIATION BOOT

The Deviation Ankle Boot was designed to provide anglers with a comfortable, performance driven footwear option that will hold up on/off the water, including non-marking lugged rubber outsoles with razor-cut siping to clear mud and other debris while maintaining the much needed traction on a wet deck. We've prioritized a thicker insole to promote noticeable shock resistance and the anti-microbial cooling liner will ensure you leave the typical footwear stench behind.

- 100% waterproof
 - Anti-microbial cooling liner
 - Razor siped outsole improves traction on wet surfaces
 - Thicker insole for shock resistance and cushioning
 - Durable built-in silicone boot band
- | | |
|------------------|------------------|
| 14-7559M8 | 14-7563M12 |
| 14-7560M9 | 14-7564M13 |
| 14-7561M10 | 14-7565M14 |
| 14-7562M11 | |

All Grundens Mens 6" Deviation Boots
\$139.95

**SHOP 24/7 FROM
THE COMFORT OF
YOUR OWN HOME**

- Up to date Pricing
- New Products
- Stock Status
- Additional product info
- And more



www.mercersmarine.com

FOOTWEAR



506 Contact us at 709-466-7430 or visit us online at www.mercersmarine.com

XTRATUF

NEW



XTRATUF 15" STEEL TOE LEGACY BOOT

Recommend half sizes order up. Triple-Dipped Shells for Extra Tough, Extra Watertight Protection. Hand-Layered Construction Adds Flex and Strength at Critical Stress Points. Open Cell Foam Footbed Insoles reduce moisture and add comfort. Slip-Resistant Non-Marking Outsole. Steel Toe meets Canadian Standard CSA Z195-14. 100% Waterproof.

Model 22271G

15-83134M7	15-83138M11
15-83135M8	15-83139M12
15-83136M9	15-83140M13
15-83137M10	15-83141M14

All Legacy Steel Toe Boots \$174.95

XTRATUF

NEW



XTRATUF 15" LEGACY BOOT

Recommend half sizes order up. Triple-Dipped Shells for Extra Tough, Extra Watertight Protection. Hand-Layered Construction Adds Flex and Strength at Critical Stress Points. Open Cell Foam Footbed Insole reduces moisture and adds comfort. Slip-Resistant, Non-Marking Outsole for Proven Traction on Wet Surfaces. Viral Penetration Resistant. 100% Waterproof.

Model 22272G

15-83056M7	15-83061M12
15-83057M8	15-83062M13
15-83058M9	15-83063M14
15-83059M10	15-83064M15
15-83060M11	

All Legacy Boots \$169.95

XTRATUF



XTRATUF 15" LEGACY BOOT - SIDE GUSSET

Triple-Dipped Shells for Extra Tough, Extra Watertight Protection. Hand-Layered Construction Adds Flex and Strength at Critical Stress Points. Slip-Resistant Non-Marking Outsole. Waterproof. Side gusset provides an additional 2.5-3 inches of shaft circumference for a customized fit. Highly resistant to many organic and inorganic acids, chemicals and contaminants.

Model 22279G

15-82033M7	15-82038M12
15-82034M8	15-82039M13
15-82035M9	15-82040M14
15-82036M10	15-82041M15
15-82037M11	

All Legacy Boots with Side Gusset \$169.95

XTRATUF



XTRATUF 15" ELITE BOOT (INSULATED)

Designed to provide the protection and durability of a Legacy boot but with an unmatched comfort for long days at sea or long hours on the dock. This boot is resistant to many acids, oils, chemicals, and contaminants. The Elite boot is built with a Spandura covered 5mm neoprene bootie, this allows the boot to be comfort rated to -29°C. Breathable Airmesh Lining. Waterproof. Slip-Resistant Non-Marking Outsole. Reinforced Rubber Layers for Durability.

Model 22613

15-82011M7	15-82015M11
15-82012M8	15-82016M12
15-82013M9	15-82017M13
15-82014M10	15-82018M14

All Elite Boots \$199.95

XTRATUF

NEW



XTRATUF 15" LEGACY NXT

100% Waterproof. SRA Rated Slip-Resistant Outsole grips the floor surface creating sure footing. Acid & Chemical Resistant. Oil Resistant. Reinforced Heel for added protection. Reinforced Ankle for added durability EVA Midsole for all day comfort.

Model MNXT900

15-82055M7	15-82059M11
15-82056M8	15-82060M12
15-82057M9	15-82061M13
15-82058M10	15-82062M14

All Legacy NXT Boots \$199.95

XTRATUF

NEW



NEW



XTRATUF 6" ANKLE DECK BOOT

Recommend half sizes order up. 100% Waterproof. Slip-Resistant Chevron Outsole. XPRESSCOOL Liner. Front and Rear Pull-On Tabs.

Model 22734 - Brown

15-82020M7	15-82024M11
15-82021M8	15-82025M12
15-82022M9	15-82026M13
15-82023M10	15-82027M14

Model 22736 - Black

15-83095M7	15-83099M11
15-83096M8	15-83100M12
15-83097M9	15-83101M13
15-83098M10	15-83102M14

All Xtratuf Ankle Deck Boots \$124.95

Xtratuf

FOOTWEAR



LADIES XTRATUF 15" LEGACY BOOT

Recommend half sizes order up. 100% Waterproof. Slip-Resistant, Non-Marking Outsole for the Best Traction on Wet Surfaces. Triple-Dipped Shells for Extra Tough, Extra Watertight Protection. Hand-Layered Construction Adds Flex and Strength at Critical Stress Points. Acid Chemical Resistant. Viral Penetration Resistant. Dual Outside and Inside Logos. Designed Specifically for a Women.

Model XWL-9TAR - Tarpon

15-83065M6
15-83066M7
15-83067M8

Model XWL-1BG - Glass

15-83103M6	15-83106M9
15-83104M7	15-83107M10
15-83105M8	15-83108M11

All Ladies Legacy Boots \$179.95



LADIES XTRATUF ANKLE BOOT

Slip-Resistant Chevron Outsole. 100% Waterproof. Recommend half sizes order up. XPRESSCOOL Liner. Pull-On Tabs.

Model XWAB-201 - Navy

15-83080M6
15-83081M7
15-83082M8

15-83083M9
15-83084M10
15-83085M11

Model XWAB-2BM - Blue

15-83087M5
15-83088M6
15-83089M7
15-83090M8

15-83091M9
15-83092M10
15-83093M11

Model XWAB-2BG - Glass

15-83115M5
15-83116M6
15-83117M7
15-83118M8

15-83119M9
15-83120M10
15-83121M11

Model XWAB0TS - Black

15-83143M5
15-83144M6
15-83145M7
15-83146M8

15-83147M9
15-83148M10
15-83149M11

All Ladies Xtratuf Ankle Boots \$129.95

CHILDRENS/KIDS XTRATUF ANKLE BOOT

Now available in popular kids sizes for the toughest youth out there. The Ankle Deck Boot Kids is the first SRA slip resistant, non-marking rubber boot on the market designed specifically for young anglers. 100% Waterproof. Breathable mesh. Open cell foam insert for all day comfort. SRA Slip resistant non-marking Chevron outsole

Navy - Model XKAB200

Childrens

15-83151M7
15-83152M8
15-83153M9
15-83154M10
15-83155M11
15-83156M12
15-83157M13

Kids

15-83158M1
15-83159M2
15-83160M3
15-83161M4
15-83162M5
15-83163M6

Purple - Model XKAB5AUR

Childrens

15-83164M7
15-83165M8
15-83166M9
15-83167M10
15-83168M11
15-83169M12
15-83170M13

Kids

15-83171M1
15-83172M2
15-83173M3
15-83174M4
15-83175M5
15-83176M6

All Childrens/Kids Xtratuf Ankle Boots

\$89.95



BOGS



MENS BOGSCCLASSIC ULTRA HIGH

100% waterproof. Durable hand-lasted rubber and a four way stretch inner bootie. Non-slip, non-marking and self cleaning outsole. Dual density, contoured EVA insole with DuraFresh anti-odor protection. Easy pull on handles. 7mm waterproof Neo-Tech insulation. Bogs Max-Wick moisture wicking lining to stay dry and comfortable. Comfort rated from temperate to -400C.

Model 51377-001

14-30873K7	14-30877K11
14-30874K8	14-30878K12
14-30875K9	14-30879K13
14-30876K10	14-30880K14

All Mens Bogs Ultra High Boots \$154.99



BOGS



MENS BOGS BOZEMAN

100% waterproof. Made with seamless construction. 30% lighter than comparable boots plus enhanced durability. Durable hand-lasted rubber with a four-way stretch inner bootie. Constructed with 7mm Neo-Tech waterproof insulation. Non-marking and self-cleaning BioGrip chemical and slip resistant outsole. Bogs Stabilizer provides natural fit and under foot support. Comfort rated to -60°C

Model 71971-001

14-84631K7	14-84635K11
14-84632K8	14-84636K12
14-84633K9	14-84637K13
14-84634K10	14-84638K14

All Mens Bogs Bozeman Bogs \$174.99



BOGS



LADIES BOGS CLASSIC SOLID

100% waterproof. Natural hand-lasted rubber and a four way stretch inner bootie. Easy pull on handles. 7mm waterproof Neo-Tech insulation. Bogs Max-Wick moisture wicking lining to stay dry and comfortable. Dual density, contoured EVA insole with DuraFresh anti-odor protection. Non-slip, non-marking and self cleaning outsole. Comfort rated from temperate to -400C.

Model 60155-005 HIGH - Black Shiny

14-81580K6	14-81583K9
14-81581K7	14-81584K10
14-81582K8	14-81585K11

All Ladies Bogs Classic High \$149.99



BOGS

Model 60156-001 MID - Black Shiny

14-84751K6	14-84754K9
14-84752K7	14-84755K10
14-84753K8	14-84756K11

All Ladies Bogs Classic Mid \$129.99



BOGS

Ladies



LADIES CLASSIC ULTRA HIGH

100% waterproof. Natural hand-lasted rubber and a four way stretch inner bootie. Easy pull on handles. 7mm waterproof Neo-Tech insulation. Bogs Max-Wick moisture wicking lining to stay dry and comfortable. Dual density, contoured EVA insole with DuraFresh anti-odor protection. Non-slip, non-marking and self cleaning outsole. Comfort rated from temperate to -40°C.

Model 51537-001 Black

14-81485K6	14-81488K9
14-81486K7	14-81489K10
14-81487K8	14-81490K11

All Ladies Bogs Classic Ultra High \$154.99



ACTON BROOK THIGH WADERS

Quality natural rubber. Anti-skidding and stable outsole. 100% waterproof.

14-325M3	14-331M9
14-326M4	14-332M10
14-327M5	14-333M11
14-328M6	14-334M12
14-329M7	14-335M13
14-330M8	

All Acton Brook Thigh Waders \$169.95



ACTON PRAIRIE "INSULATED" HIP WADERS

Waterproof natural rubber. Removable triple density liner (Same replacement liner as the regular Acton Prairie). Natural rubber outsole. Net lined leg. Adjustable strap at thigh.

15-2219M3	15-2225M9
15-2220M4	15-2226M10
15-2221M5	15-2227M11
15-2222M6	15-2228M12
15-2223M7	15-2229M13
15-2224M8	

All Acton Prairie Waders \$184.95



AQUASEAL

Repair all types of gear failures with Aquaseal FD. It's a clear, waterproof urethane adhesive that comes in a handy 0.75 oz tube. After it cures, it becomes a flexible, rubber glue that is ideal for fixing outdoor gear that's in constant motion. It also offers excellent abrasion resistance. So, when fishing waders rip on the river or a wetsuit tears while diving through prickly corals, don't throw it away. Fix it with Aquaseal FD. It's also useful as a seam sealer. Don't let rips, tears, and holes stop you. Patch it up with the all-purpose Aquaseal FD and stay dry.

20-2130M0.75oz.....	12.95
---------------------------	-------



ACTON PROTECTO HIP BOOT

29" hip boot. 100% natural rubber. Steel toe and plate, electric shock resistant and non-marking outsole.

15-2084M6	15-2088M10
15-2085M7	15-2089M11
15-2086M8	15-2090M12
15-2087M9	15-2091M13

All Sizes \$209.95



ACTON PROTECTO CHEST WADERS

The perfect safety boot for sewage workers, claims adjusters or for any other occupation needing a totally waterproof natural rubber chest wader. Moreover, it meets CSA and ESR standards. Its natural rubber outsole is adherent, non marking, stable and abrasion resistant.

15-2143M6	15-2147M10
15-2144M7	15-2148M11
15-2145M8	15-2149M12
15-2146M9	15-2150M13

All Sizes \$234.95



SHOE GOO II

Designed to repair footwear, leather, rubber, vinyl & canvas. Can be used on net buoys, fenders, wetsuits & some foul weather suits. 1 oz tube.

14-122M.....1oz.....	7.95
----------------------	------



NEW



GREEN TRAIL CHEST WADERS

Very resistant nylon. Vinyl covered interior. Adjustable drawstring at the waist. Quick closing straps. Inside pocket. PVC boots. Available with Traction or Felt sole.

Traction Sole

15-2801M4	15-2806M9
15-2802M5	15-2807M10
15-2803M6	15-2808M11
15-2804M7	15-2809M12
15-2805M8	15-2810M13

All Traction Sole \$119.95

Felt Sole

15-2814M6	15-2818M10
15-2815M7	15-2819M11
15-2816M8	15-2820M12
15-2817M9	15-2821M13

All Felt Sole \$159.95

NEW



GREEN TRAIL CHEST WADERS

Very resistant nylon. Vinyl covered interior. Adjustable drawstring at the waist. Quick closing straps. Inside pocket. PVC boots. Available with Traction or Felt sole.

Traction Sole

15-2825M6	15-2830M11
15-2826M7	15-2831M12
15-2827M8	15-2832M13
15-2828M9	
15-2829M10	

All Traction Sole \$79.95

Felt Sole

15-2836M6	15-2840M10
15-2837M7	15-2841M11
15-2838M8	15-2842M12
15-2839M9	15-2843M13

All Felt Sole \$114.95

COMPAC

KIDS



COMPAC KIDS HIP WADERS

Nylon/PVC construction. Rubber cleated sole. Elasticized belt loops.

14-276M10	14-281M2
14-277M11	14-282M3
14-278M12	14-283M4
14-279M13	14-284M5
14-280M1	14-285M6

All Sizes \$64.95

www.mercersmarine.com



- Always Open
- Sale & Feature items
- View Catalogue



- Thousands of products
- Updated Regularly
- Up to date Pricing



- Mobile Friendly
- Shop from anywhere at anytime

Also find us on





STREAMSIDER

STREAMSIDER GUARDIAN BREATHABLE MEN'S CHEST WADER (2150B)

3 ply polyester construction. Outer seams for superior abrasion & stress resistance. 3mm thick neoprene booties. Adjustable, quick release suspenders. Wading belt. Draw string top with inside chest pocket. Waterproof rating: 10,000 mm. Breathable rating: 3,000g/m²/day.

- 14-419MSm 14-422MXL
- 14-420MMed 14-423M2X
- 14-421MLg

All Sizes \$189.95



NEW

COMPAC

GUARDIAN HIP WADERS

Waterproof and breathable. 3 ply polyester construction. Outer seams for superior abrasion & stress resistance. 3mm thick neoprene booties. Wading belt. Gravel guard.

- 14-432MSm 14-435MXL
- 14-433MMed 14-436M2X
- 14-434MLg

All Sizes \$164.95



NEW

COMPAC

PREMAX II BREATHABLE WADERS

Waterproof rating: 10,000mm/day. Front pocket with waterproof zipper. Fleece lined hand warmer pocket. Convenient wading belt. Reinforced knee patches for improved durability. Adjustable gravel guard leg cuffs. Textured tape seal on neoprene foot for added grip. Breathable rating: 4,000g/m²/day.

- 14-336MSm 14-339MXL
- 14-337MMed 14-340M2X
- 14-338MLg

All Sizes \$249.95



FELT SOLE REPLACEMENTS

0.25" thickness. Perfect for waders, wading shoes and rubber boots. High density polyester felt for maximum grip. Includes: 1 pair of felt soles, tube of adhesive.

- 14-380MOne Size31.95



MEN'S STREAMLINE SPIRIT "FELT SOLE" WADING SHOE

Made with a tough water resistant leather and full Goodyear stitching for long lasting performance. Abrasion/ water resistant synthetic leather with rugged K068 nylon upper. The boots also feature reinforced toe and heel wrap, padded ankle support and a contoured speed lace system.

- 14-397M7 14-401M11
- 14-398M8 14-402M12
- 14-399M9 14-404M13
- 14-400M10

All Sizes \$159.95



Shop or Browse Online 24/7

at mercersmarine.com



REPLACEMENT BOOT LINERS

FOR ACTON PRAIRIE, ADVENTURE & "OLDER" EXPLORER AND ICELANDERS (A4941-B16)

14-010K3	14-016K9
14-011K4	14-017K10
14-012K5	14-018K11
14-013K6	14-019K12
14-014K7	14-020K13
14-015K8	14-021K14

All Sizes \$38.95

FOR BAFFIN TITAN (POLA-ML02)

14-3159K6	14-3164K11
14-3160K7	14-3165K12
14-3161K8	14-3166K13
14-3162K9	14-3167K14
14-3163K10	14-3168K15

All Sizes \$94.95

FOR BAFFIN TRAPPERS (L8592A70)

14-895K7	14-899K11
14-896K8	14-900K12
14-897K9	14-901K13
14-898K10	

All Sizes \$49.95

FOR BAFFIN HUNTERS & REFINERY (L8562A40)

14-296K6	14-300K10
14-297K7	14-301K11
14-298K8	14-302K12
14-299K9	14-303K13

All Sizes \$40.95

FOR BAFFIN WORKHORSE & BLASTCAP (R0005MS)

14-2547K7	14-2551K11
14-2548K8	14-2552K12
14-2549K9	14-2553K13
14-2550K10	14-2555K14

All Sizes \$74.95

FOR BAFFIN MEN'S IMPACT (400R122)

14-3132K7	14-3137K12
14-3133K8	14-3138K13
14-3134K9	14-3139K14
14-3135K10	14-3140K15
14-3136K11	

All Sizes \$82.95

FOR BAFFIN LADIES IMPACT (R0027WS)

14-612K6	14-615K9
14-613K7	14-616K10
14-614K8	14-617K11

All Sizes \$82.95

FOR BAFFIN CONSTRUCTOR (POLA-ML01)

14-3150K7	14-3155K12
14-3151K8	14-3156K13
14-3152K9	14-3157K14
14-3153K10	14-3158K15
14-3154K11	

All Sizes \$94.95

FOR BAFFIN APEX (4000R124)

14-5533K7	14-5538K12
14-5534K8	14-5539K13
14-5535K9	14-5540K14
14-5536K10	14-5541K15
14-5537K11	

All Sizes \$82.95

FOR BAFFIN LADIES STORM (L8604B30)

14-1023K5	14-1026K8
14-1024K6	14-1027K9
14-1025K7	14-1028K10

All Sizes \$40.95



bama

Boot Liners

BAMA INSOLES

The Original Bama. A great insole. Guaranteed to hold firm in rubber boots. Acrylic fleece insulation with outer reinforced cotton shell to absorb moisture. Washable.

14-569M.....(4/5).....	19.95
14-570M.....(6/7).....	19.95
14-571M.....(8/9).....	19.95
14-572M.....(10/11).....	19.95
14-573M.....(12/13).....	19.95
14-574M.....(14).....	19.95



MEN'S INSOLES

General purpose insole of wool and polypropylene. Grey and white with radiantex film for warmth. Fits most standard boots.

14-1217P.....6	14-1222P.....11
14-1218P.....7	14-1223P.....12
14-1219P.....8	14-1224P.....13
14-1220P.....9	14-2074P.....14
14-1221P.....10	

All Sizes \$7.95



NEOPRENE SOCKS

Neoprene foam core with 4 way stretch nylon outer. 10" tall sock has comfortable 3 piece design. Heavy binding around top. Reversible.

12-096M.....Sm / Med.....	23.25
12-097M.....Lg / XL.....	23.25

FOOTWEAR



WALTERS LEATHER KIT

All you need to clean and protect leather. Eco-Friendly conditioner for cleaning shoes, furniture and bags. Waterproofer helps repel liquids and stains. Soft, lint-free cleaning cloth included.

15-1740P 9.95



WALTERS SUEDE KIT

All you need to clean and protect suede. Multi-function brush cleans all colours of suede safely. Waterproofer helps repel liquids and stains. Soft, lint-free cleaning cloth included.

15-1741P 9.95

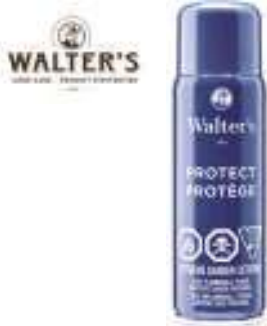

WALTERS LEATHER PROTECTOR (SPRAY)

Suited for all kinds of leather, suede, nubuck and textiles. PFOS/PFOA Free formula. Creates an invisible waterproof barrier to help repel dirt and stains.

14-827P 11.95



WALTERS CLEAN WIPES

Helps remove dust, dirt and salt stains on the go. Suited for all kinds of leather, suede, nubuck and textiles. Natural ingredients in a compact resealable pack.

15-1742P 9.95



WALTERS LEATHER PROTECTOR (DUBBIN)

Moisturizes, nourishes and waterproofs. Suited for all kinds of smooth leathers. Built in sponge applicator.

15-1700P 9.95



WALTERS BOOT MEMORY INSOLES

Memory foam technology for superior comfort. Suited for workboots and shoes.

15-1762P Mens Sizes 6-8 19.95

15-1763P Mens Sizes 9-11 19.95

15-1764P Mens Sizes 12-14 19.95



WALTERS CREAM POLISH

Nourishes, protects and shines. Suited for all kinds of smooth leathers. Contains natural carnauba wax.

15-1728P Black 9.95

15-1729P Dark Brown 9.95

15-1730P Brown 9.95

15-1731P Neutral 9.95



WALTERS WINTER INSOLES

Enjoy the warmth and comfort. Suited for most types of shoes and boots. Metalized shield reflects cold; foam layer adds cushioning.

Ladies Sizes

15-1680P 5

15-1681P 6

15-1682P 7

15-1683P 8

15-1684P 9

15-1685P 10

Mens Sizes

15-1686P 7

15-1687P 8

15-1688P 9

15-1689P 10

15-1690P 11

15-1691P 12

All Sizes \$9.95



WALTERS KEVLAR LACES

15-1765P 54" 9.95

15-1766P 72" 9.95



WALTERS WORKBOOT LACES

Black

15-1767P 45" 4.29

15-1768P 54" 4.29

15-1769P 63" 4.29

15-1770P 72" 4.29

Tan/Yellow

15-1771P 54" 4.29

15-1772P 63" 4.29

15-1773P 72" 4.29

Brown

15-1774P 63" 4.29

15-1775P 72" 4.29



WALTERS REPLACEMENT INSOLES

Instantly adds comfort to boots and shoes. Aegis microbe shield technology. 56 perforations help to circulate air and to keep feet cool.

15-1776P Mens Size 6 5.99

15-1777P Mens Size 7 5.99

15-1778P Mens Size 8 5.99

15-1779P Mens Size 9 5.99

15-1780P Mens Size 10 5.99

15-1781P Mens Size 11 5.99

15-1782P Mens Size 12 5.99

15-1783P Mens Size 13 5.99



WALTERS ECO INSOLES

Keeps the insole of the shoes intact, therefore prolonging their lifespan. Help keep feet dry and odour free for all day comfort.

Ladies Sizes

15-1665P 5

15-1666P 6

15-1667P 7

15-1668P 8

15-1669P 9

15-1670P 10

Mens Sizes

15-1671P 7

15-1672P 8

15-1673P 9

15-1674P 10

15-1675P 11

15-1676P 12

All Sizes \$9.95

Grangers



GRANGERS G-WAX - NATURAL BEESWAX

Grangers G-Wax is a traditional wax designed to add rain and stain protection to all leather footwear. Easy to apply, and offering a balance between excellent water-repellency, deep nourishment, and good levels of breathability, this product is the perfect way to keep footwear looking and performing at its best.

20-4004M80g 15.95

Grangers



GRANGERS ODOUR ELIMINATOR

Natural treatment that stop odors. The flower extract use is preventing mushroom and bacteria to reproduce itself. Killing the odor at it's source. Works on all kinds of fabric and footwear, helmets – and any other outdoor gear that can't easily be washed and dried. Simple spray-on application

20-4006M100ml 12.95

Grangers

NEW



GRANGERS PERFORMANCE WASH CONCENTRATE

Powerful cleaning. Neutralises odours. No residue. Performs the same in hard and soft waters . Enhances any existing water-repellent finish. 100% PCR and Ocean Waste Plastic (OWP) bottle. Bluesign approved. PFC-free.

20-4011M300ml 17.95

Grangers

NEW



GRANGERS FOOTWEAR REPEL PLUS SPRAY

Superior water-repellency. Maximises breathability. Conditioning. Suitable for all uppers. 100% PCR and Ocean Waste Plastic (OWP) bottle. Bluesign approved. PFC-free.

20-4012M275ml 19.95

Grangers



GRANGERS PERFORMANCE REPEL

For all waterproof apperal. Advanced fluorocarbon-free formula add durable water repellency to all outdoor fabrics while maintaining breathability.

20-4009M275ml 22.95

Grangers



GRANGERS TENT & GEAR REPEL

Grangers Tent + Gear Repel is a paint-on waterproofer designed to protect all outdoor gear and equipment from rain and stains.

•Replicates the original water-repellent finish found on outdoor products.

• Suitable for use on all fabric.

• Easy paint-on application.

20-4002M500ml 26.95

Grangers



GRANGERS CLOTHING WASH & REPEL

Grangers Clothing Wash + Repel is a unique wash-in product designed to deliver effective cleaning and durable water-repellency in a single wash cycle.

•Formulated to clean and restore the water-repellency of all outdoor clothing.

•Fluorocarbon-free and environmentally responsible.

•Requires heat activation – ideally via a tumble dryer.

•Suitable for use on all Gore-Tex and eVent garments.

•Suitable for Cleaning Clothing and Equipment

20-4005M300ml 23.95

Grangers



GRANGERS DOWN WASH KIT

Down Wash, a powerful, yet gentle, cleaner specifically formulated to clean all your down and synthetic down-filled articles without damaging or inhibiting insulation or hydrophobic properties.

20-4013M300ml 31.95

Grangers

NEW



GRANGERS WASH & REPEL DOWN 2 IN 1

Specially formulated to restore the water-repellent finish of all down-filled articles. Superior cleaning. 2-in-1 formulation. Bluesign approved. PFC-free.

20-4010M300ml 23.95



Outdoor Recreation





WORKMAN COOLER BAGS

Durable polyester outer with foam insulation. Reflective metallic finish inner lining. Top access with large zipper. Side pocket with flap closure. Additional side mesh flap pocket. Web top carry handle. Detachable top carry strap. Dimensions 11" x 10" x 9"

- 20-666MGrey25.95
- 20-667MCamo30.50



FROBISHER CANVAS DAYPACK

Heavy cotton canvas. Leather trim and pocket closures. One main compartment. 2 large side pockets. Padded inner computer pocket sleeve. Canvas shoulder straps with foam padding. Topweb carry handle.

- 20-375M.....17" x 13" x 5 1/2" (Olive.).....55.50



NATO RUCKSACK

•European style •22 oz. cotton canvas •2 side pockets •Zippered front pocket •Zippered top lid pocket •Hang loop.

- 20-011M.....20" x 13" x 7 1/2" (Olive.).....47.25



G.I. STYLE DUFFLE BAG

•Heavy duty, water repellent duck •May be carried with either sturdy shoulder strap or center handle •Grommets & "D" rings for top closure and padlocking.

- 20-017M36" x 18" / green.....19.95



EURO RUCKSACK

Heavy duty canvas fabric. Extra large size. Padded web back straps. 3 outer pockets. Inner flap pocket. Double reinforced bottom. Olive colour is washed for that "used surplus" look.

- 20-511M.....17"H x 16"W x 5"D50.50



WEB RUCKSACK

2 adjustable shoulder straps. Padded comfort back band 3 outside pockets.

- 20-560P13" x 15 1/2" x 16"31.95



WEB HAVERSACK (GRUB BAG)

Adjustable and detachable shoulder strap. Buckle closure with reinforced tips. 11 1/2" x 9" x 4 1/2"

- 20-514PGreen12.95
- 20-515PBlack.....12.95
- 20-516PBlue12.95



STORAGE CASES/SURVIVOR BOXES

Highly durable Polypropylene construction. Lockable (lock not included). Rubber gasket sealed lid for water resistance. Stackable for easy storage.

- 20-1000M6.75" x 8.75" x 4.5"13.95
- 20-1001M10" x 7" x 3.25"17.25
- 20-1002M11.5" x 5.25" x 7.25"21.25
- 20-1003M13.75" x 7.5" x 8.75"33.25
- 20-1004M16" x 9" x 10.25"43.25
- 20-1005M.....18" x 19.25" x 8.25"65.50



BACKWOODS MUNGO RUCKSACK

600 denier cordura polyester. Quality rippled EVA Rubber bottom. Padded shoulder straps. **New and Improved.**

20-005M.....	15 LITRE	62.95
20-006M.....	25 LITRE	79.95
20-007M.....	40 LITRE	91.95

NESSMUCK PACKSACK

Heavy cotton canvas.Padded back with mesh and foam patches for extra comfort.Leather main and pocket closures.One main compartment.Zippered front pockets. Canvas shoulder straps with mesh and foam padding.

20-1205M.....	21"H x 11"W x 7"D	59.95
---------------	-------------------------	-------



NORTH 49 "FLY AWAY" ROLLING DUFFLE BAG

Travel and transport your belongings with ease using North 49s Fly Away Folding Duffel Bag with Wheels. The spacious main compartment can hold up to 90 litres and the bag effortlessly folds away for storage when not in use. For loads too heavy to carry, the easy glide wheels make lugging around heavy gear no problem.

20-528M	28.5" x 14" x 13"	37.50
---------------	-------------------------	-------



ROLLING SPORT DUFFLES

Constructed of rugged 600 denier ripstop polyester fabric with PVC backing.Large size duffel is ideal for travel, camping and storage.Wheels and retractable pull handle for easy rolling.Large main zippered compartment.Outer zipper and flap closure pockets. Detachable shoulder strap with plastic shoulder patch. Carry handle.Side haul handles.Plastic skid pads protect bottom of bag.

20-526M.....	35" x 15" x 14"	118.95
--------------	-----------------------	--------



VINTAGE CAMPER PACKSACK

Heavy cotton canvas and leather pocket closures.One main compartment with 2 outside pockets

20-1204M	17"W x 19"H	47.50
----------------	-------------------	-------





MIL-SPEX TACTICAL FRAM PACK

Large main compartment is top loading with heavy duty zipper closure. Large front-loading external front zip pocket with mesh inside pocket layer. Two long side zip pockets. Medium sized lower front zip pocket. Discreet bottom zip pocket contains rain pack cover. Zippered top compartment. Padded waist, back and shoulder harness. 2 side, + front & back lift / hanging handles. Heavy duty PALS-style grid webbing on front, top, and sides for attaching extra custom gear. Front PALS webbing has hook & loop outer for extra stability. D-loops and webbing chain on shoulder straps and waist harness. Removable frame inserts for easy packing/transport when not in use.

20-203M.....21" x 16" x 29"179.25



CAMO MARINE DUFFLE BAG

Made of strong and tough PVC/ POLYESTER fabric. Handle with padded strap holder. Side compression straps aid in attaching items like umbrellas. Padded end grab loops for comfortable carrying. Detachable shoulder carry strap. Heavy duty

20-029P21" x 13.5" x 10"77.95
20-030P.....28.5" x 16" x 12.5"101.25



MIL-SPEX BLACK OPS TACTICAL PACK - 60 LITRE

Large capacity (60L) heavy duty backpack constructed in heavy polyester with upgraded webbing, zippers and buckles. Large main compartment (2 inner mesh zip pockets, padded laptop sleeve, organization sleeve, load securing quick release strap). Front compartment with cover zip closure. Outer compartment with inside organizer. 2 side zippered pouches. 2 front zippered pockets. Top zippered stash pocket. 4 way adjustable shoulder straps. Adjustable sternum strap. Detachable adjustable hip belt. Top and dual side reinforced webbing haul handles. 4 side compression straps. Hardened back panel with deep cushion outer padding. Dual side hydration tube openings. 18" x 14" x 19.5"

20-205POlive110.95
20-206PBlack110.95



MIL-SPEX BRIGADE TACTICAL PACK - 110 LITRE

Capacity: 110 litres. Constructed from heavy-duty polyester with upgraded webbing. Large top-loading main compartment with drawstring closure. Top lid with quick-release buckles. Front zip pocket with additional small zip pocket. Two side zip pockets and top lid pocket. Small bottom zip pocket. Bottom extension zipper adds extra room. Adjustable shoulder straps. Embellished front patch pad. Top, bottom, and side gear straps.

Expanded Size: 35.5" x 16" x 11.75"
20-207POlive80.95
20-208PBlack80.95



RAPID RUNNER PACK

Rugged heavy duty waterproof outer fabric. Large top opening. Padded back and articulated shoulders. Rigid backboard for added stability. Side and vertical compression straps stabilize large loads. Curved shoulder straps with sternum adjuster. Foam mesh backpanel for breathability. Top lid organizer. 2 side elastic mesh pockets. Roll top closure for added protection. Padded top grab handle. **Note: not intended to be submerged.**

20-1206M.....(BLACK) 21"H x 13"W x 10"D75.95
20-1203M.....(CAMO) 21"H x 13"W x 10"D80.50



NEOPRENE SHOT SHELL BELT

Holds 25 shot shells. Fits up to 3" shells. Adjustable up to 55" (140cm). Comfortable and secure. Keeps shells clean and dry. (Shells not included).

20-121M.....34.95



**Shop or Browse
Online 24/7
at
mercersmarine.com**



MARINE DUFFLE BAGS

Made of strong and tough PVC/POLYESTER fabric. Handle has padded strap. Side compression straps and padded end grab loops for comfortable carrying. Detachable shoulder carry strap. Heavy duty zippers for easy access. Molded padded reinforced bottom.

- 20-233P16" x 11" x 9"63.50
- 20-234P21" x 13.5" x 10"72.50
- 20-235P28.5" x 16" x 12.5"81.95



MARINE DUFFLE BAGS

Constructed in strong durable PVC laminate fabric. Large main compartment with heavy duty "U" zipper for easy access. 2 web carry handles. Double detachable padded shoulder straps for easy carry. 2 side web grab handles web straps and ladderlock buckles on each side for attaching extra gear side reinforcing webbing with daisy chain loops. ID patch. Double reinforced bottom

- 20-021P23.5" x 14"81.95
- 20-022P27.5" x 15"95.95
- 20-023P32" x 19"110.95



FLY DRY DUFFLE BAGS

Made of strong PVC / Polyester fabric. Handle with padded strap. Side compression straps. Padded end grab loops for comfortable carrying. Detachable shoulder carry strap. **Detachable double shoulder straps for carrying on back.** Heavy duty U zippers for easy access. Moulded padded reinforced bottom.

- 20-046P21" x 13 1/2" x 10"81.95
- 20-047P28 1/2" x 16" x 12 1/2"95.95



WHITE WATER PACKS

Constructed of durable PVC/polyester laminated fabric. Waterproof heat sealed seams. Rounded bottom. Roll down waterproof closure. Rugged grab handle. Detachable, adjustable shoulder straps. Waist belt quick release buckle.

- 20-082P85 L (34" x 24" x 15.5") Yellow57.95
- 20-083P110 L (38.5" x 24" x 16") Blue63.95



WATERPROOF DRY DUFFLE BAG

Made of strong and tough PVC/POLYESTER laminate fabric. Waterproof heat sealed seams. Heavy duty roll down waterproof closure. Quick release buckles are used to hold closure tight. Reinforced strap attachment points. Padded grab loop. Ideal for diving equipment, boating and whitewater.

- 20-253P30" x 14"68.25



WILDWATER DUFFLE BAG

Heavy duty PVC/DACRON Laminate. Heat seal seams allow for waterproof construction. Top zipper with hook, loop flap, and detachable carry strap.

- 20-254P30" x 15"53.50



WATERPROOF DRY SACKS

Rugged nylon outer bags with waterproof lining. All seams are stitched & then hot air taped for waterproofness. Round bottoms for full loading capability. Web top folds over closure and doubles as handle.

- 20-479P9 1/2" x 21" (yellow)22.50
- 20-480P12" x 24" (red)25.50
- 20-481P13" x 36" (green)28.95
- 20-482P15" x 40" (royal)33.95





CANYON POLARIZED SUNGLASSES

Superior comfort, durability and performance make the Streamside Canyon Polarized Sunglasses ideal for outdoor enthusiasts. The lens offer clarity from every angle and filter out 100% of UVA, UVB and UVC rays in order to keep your eyes protected. Anti-scratch coating. Durable frames.

- 60-073RBrown22.95
- 60-074RSmoke22.95



Smoke

TUNDRA POLARIZED SUNGLASSES

100% protection UVA, UVB, UVC 400nm. Anti-scratch coating. Durable black frames. Brown or smoke coloured lenses

- 60-094RAmber19.95
- 60-095RSmoke19.95



RAPALA SPORTSMAN "POLARIZED" SUNGLASSES

Stylish full wrap design reduces side glare. High quality polarized lens. 100% UV protection. Great for angling and boating. Lightweight and comfortable.

RSG-SG Model

- 60-071MSmoke/Grey32.95



SUBURBAN POLARIZED SUNGLASSES

100% protection UVA, UVB, UVC 400nm. Anti-scratch coating. Durable black frames. Brown or smoke coloured lenses

- 60-096RAmber19.95
- 60-097RSmoke19.95



Smoke

SIERRA POLARIZED SUNGLASSES

100% protection UVA, UVB, UVC 400nm. Anti-scratch coating. Durable black frames. Brown or smoke coloured lenses.

- 60-092RAmber19.95
- 60-093RSmoke19.95



RAPALA PROGUIDE "POLARIZED" SUNGLASSES

High quality polarized lens. 100% UVA/UVB protection. Shatter resistant. Stylish flash, mirror finish. Great for angling and boating. Lightweight and comfortable.

RSG Model

- 60-069MAmber32.95
- 60-070MSmoke/Grey32.95

www.mercersmarine.com



- Always Open
- Sale & Feature items
- View Catalogue



- Thousands of products
- Updated Regularly
- Up to date Pricing



- Mobile Friendly
- Shop from anywhere at anytime

Also find us on





STAINLESS STEEL WIRE

Supplied in 1 lb spools or 20ft coil. Diameter 0.025". Size #21 (Not legal for "Snare Wire" in NFLD & Lab.)
 20-123K1lb Spool.....31.95
 20-027P20ft Coil2.39

BRASS SNARE WIRE

Supplied in 1 lb spools or 20ft coil. Diameter 0.025". Size #21
 20-174K1lb Spool.....56.95
 20-173P20ft Coil3.29

PICTURE CORD SNARE WIRE

Steel Braided
 Supplied in 20' coils. Diameter 0.031"
 20-172P3.29



SABRE DOG ATTACK DETERRENT

Provides approx 25 one second bursts of spray. Hard plastic case with belt clip and key ring. Ideal for walking, running, hiking, and cycling. Contains 0.50% capsaicin. Effective at maximum range of 3 metres (10ft).

20-684PClear Case17.25
 20-685PPink Case (Ladies)17.25

BEAR ATTACK DETERRENT

Safety clip. Easy one hand operation. Loop handle easy to clip to waist or pack. Effective at maximum range of 5.5 metres (18ft).

20-686M225g (0.857% capsaicin)62.50
 20-688M325g (1% capsaicin)92.95
 20-687MHolster (Fits 20-686 only)8.95



ORANGE FLAGGING TAPE

56-033M3mil x 1" x 50 yds2.39



BEAR BELL

This compact bell creates a steady ringing to alert others or warn animals of your presence, reducing encounters with animals such as bears and moose. Easily attach to clothing or a pack with its included hook and loop strap. A magnet in the storage bag eliminates noise when it is not needed.

20-618M3.95



LOG BOOKS

Ring coiled log books feature plastic cover.

58-063MMe Shed (8.5" x 11")18.50
 58-064MCabin (8.5" x 11")18.50
 58-065MNautical/Nav. (8.5" x 11")23.95
 58-067MBoaters Log/Guest (8.5" x 11")18.50
 58-060MRV Log Book (8.5" x 11")23.95
 58-062MGuest (10" x 7")19.95
 58-069MHockey Log Book (8 1/2" x 11")22.95



CHEESECLOTH

Made from 100% cotton weave. (3yd x 33 1/2")
 20-045R6.95



NOMAD SLEEPING BAGS

Rectangular design. Double layer polysoft polyester fill. Polyester outer shell. Polyester lining for comfort. Draft tube. Includes compression stuff bag.

NOMAD 2

- Fill Weight: 2 lbs (0.9kg)
- Comfort range: 0°C
- Colour: Red/Black

20-240M64.95

NOMAD 3

- Fill Weight: 3 lbs (1.36kg)
- Comfort range: -5°C
- Colour: Royal/Black

20-241M72.95

NOMAD 4

- Fill Weight: 4 lbs (1.8kg)
- Comfort range: -10°C
- Colour: Forest/Black

20-242M80.50

NEW



Sleeping Bags

ARCTIC STAR 12 SLEEPING BAG

Heavy duck canvas shell. Hollow microfiber insulation. Cotton flannel lining. Oversizes draft tubes along zippers. Adjustable chest baffles. Machine washable-hanging loops to dry. Heavy duty double zippers. Polyester duffle style carry bag.

Arctic Star 12

- Fill Weight: 12 lbs (5.4kg)
- Comfort range: -50°C

20-245M360.25



COMPACT SLEEPING BAG

Synthetic filled rectangular bag. Full length zipper. Elastic hood closure for warmth. 200 gm polyester fill. Rated to 0°C. Complete with carry bag. Look at the size!!!

20-262M88" x 31"60.50



Outer corner zipper pocket for stashing essentials



DOUBLE COMFORT SLEEPING BAG

Large rectangular design ideal for extra space or for 2 people. 100% Polyester outer. Soft fleece lining. 6 lbs. HOLLOWSOFT insulation. No. 10 zippers. Can be reconfigured into 2 separate sleeping bags. Complete with 600D polyester carry bag.

Fillweight: 6 lbs. Total weight: 9.8 lbs. Comfort range: -3° C

20-244M67" x 77" 153.95

OUTDOOR RECREATION



Specifications

- Outer bag:**
 •Temperature rating: -20°C
 •Fill weight: 6.5 LBS (3KG)
- Inner bag:**
 •Temperature rating: -7°C
 •Fill weight: 3 LBS (1.35KG)

Ensemble:

- Temperature rating: -42°C
 •Fill weight: 9.5 LBS
 •Total weight: 20 LBS (9 KG)
 •Size: 78" (91"with hood) x 36" x 10"

20-259M..... 472.95

BASECAMP SLEEPING BAG

•Extreme cold climate bag system •2 separate sleeping bags offer 3 optional configurations •65% polyester/ 35% cotton outer fabric •100% cotton flannel lining on each bag
 •Additional detachable flannel lining •Double layered polysoft insulation on both inner and outer bags •No. 10 delrin zippers •Zip off hood •Full length draft tube •Front zippered pocket •Web tie straps with quick release buckles •Web hanging loops for airing •Complete with zippered duffle bag carry case.



FRONTIER 9

- Fill weight: 9 LBS (4 kg)
 •Temperature rating: -25°C (-13°F)
 •Colour: NAVY

20-256M..... 301.95

FRONTIER 11

- Fill weight: 11 LBS (4.5kg)
 •Temperature rating: -35°C (-31°F)
 •Colour: OLIVE GREEN

20-257M.....332.25

"FRONTIER" SLEEPING BAGS

•Heavy weight poly cotton twill outer shell •Flannel lined •Double layered offset hollow polyester insulation •Insulated hood with draw cord and cordlocks •Large No.8 open ended cap delrin zipper with double zipper pulls •Full length insulated draft tube •Zippered mesh outer pocket •Web straps with 'D' rings on bottom of bag for hanging and airing •Attached web straps with quick release buckles for rolling •Complete with nylon duffle bag style carry bag. Size: 84" (210 cm) + 12" (30 cm) hood • Width: 41" (104 cm)



RWD Polar Star 8

- Fill weight: 21 LBS (9.5kg)
 •Temperature rating: -45°C (-49°F)
 •Colour: Brown/Plaid Print

20-260M..... 452.95

RWD POLARE STAR 8 SLEEPING BAG

8 in 1 sleeping bag system with separate removable outer, inner, and liner sections. Customize temperature by switching over/under layers. Can also be used as a double wide sleeping bag.
Outer Bag: 7 oz polyrock outer fabric. Lining: Cotton/Poly printed flannel lining. Fill: 7 lbs. Q4X Superloft double layer offset quilt. #10 zipper with pulls. Full length insulated draft tube. Zipper guard. Anti-snap webbing.
Inner Bag: Outer: 210T Cire polyester. Lining: Cotton/Poly printed flannel lining. Fill: 3 lb. Q4X Superloft single layer. #8 zipper. Full length insulated draft tube.
Liner: 220 g/m2 fleece. #8 zipper.



FOLDING BED COT

Ideal for camping, beach or as a guest bed. Aluminum frame construction is lightweight, yet very sturdy. Durable 600 denier polyester cover. Folds compactly for easy storage. Carry bag with handle. Weight: 10.5lbs

Dimensions

Folded : 4" x 7" x 37"

Open : 26" x 75" x 16"

20-910M.....130.95



TRAILSIDE ALUMINUM COT

Ideal for camping, beach or at home as a guest bed. Extremely lightweight and sturdy aluminum X-frame. 600-denier nylon fabric for lasting performance. Folds up compactly for easy transportation and storage. Color: Forest Green. Includes carry bag. **Unfolded Size** 82" x 32" x 18"

20-2244M.....160.95



FOLDING PICNIC TABLE SET

This terrific, fold-away picnic table is ideal for numerous occasions, both outdoors and indoors. Table top and seats are made of a very tough, durable plastic with metal frame and legs. Folds to close as a suitcase that weighs only 24 lbs, thus making it easy and practical to carry. Will not rust. Very stable and secure. Sets up in a matter of seconds with a few simple steps. Will seat 4 people comfortably.

Carry Case measurements: 34" x 15" x 4"

20-057P..... 146.95



SELF-INFLATING MATTRESS

Terrific all-purpose mattresses for backpacking and car camping trips, adding extra comfort and insulation while in camp.

- Fully bonded foam-fabric construction.
- Single high-flow air valve.
- Comes with a stuff sack and web straps for easy packing and storage.

Regular Size

Deflated Size: 74" x 21.6"

Inflated Thickness: 1.2"

20-2310M.....62.95

X-Large Size

Deflated Size: 74" x 26"

Inflated Thickness: 2"

20-2311M.....98.95



GUIDEREST SELF-INFLATING MATTRESS

These lightweight and very compact technical mats are ideal for mountaineering and backpacking trips.

- Die-cut open-cell foam for rapid inflation/deflation, excellent insulation and extra comfort on rough or uneven surfaces.
- Top Fabric: Lightweight and durable, TPU-coated diamond ripstop nylon fabric with an anti-slip surface to help reduce sleeping bag slippage.
- Bottom Fabric: Heavy-duty, TPU coated nylon with a non-slip surface.
- Top quality, super strong brass valve for quick and easy inflation and deflation. Will not break in sub-zero weather.
- Comes with a stuff sack and repair kit

Full Size

Deflated Size: 72" x 20"

Inflated Thickness: 1.5"

20-2312M.....99.95



CHINOOK POLAR PEAK SLEEPING BAG

- Temperature Rating: -20°C
- Size: 83" x 32" x 20"
- Shape: mummy
- Construction: horizontal channel design
- Outer Shell: ripstop nylon

- Lining: polyester
- Filling: 32 oz (900 g) of 90/10 grey goose down, 600+ fill power
- Zipper: #5 YKK 2-way
- Stuff Sack: compression bag
- Total Weight: 3.2 lbs (1.35 kgs)
- 20-2202M..... 389.95



CHINOOK POLAR ICE SLEEPING BAG

- Temperature Rating: -30°C
- Size: 83" x 32" x 20"
- Shape: mummy
- Construction: horizontal channel design
- Outer Shell: ripstop nylon

- Lining: polyester
- Filling: 42 oz (1200 g) of 90/10 grey goose down, 600+ fill power
- Zipper: #5 YKK 2-way
- Stuff Sack: compression bag
- Total Weight: 3.5 lbs (1.65 kgs)
- 20-2203M..... 479.95



The Kodiak Peak is great for outdoor winter pursuits, when temperatures are not quite so extreme. Expedition-ready features such as Insufil® Thermo insulation, ergonomic head gasket and foot box, draft tubes and neck collar.

CHINOOK KODIAK PEAK II SLEEPING BAG

- Temperature Rating: -20°C
- Size: 90" x 34" x 22"
- Shape: mummy
- Construction: three layer
- Outer Shell: ripstop polyester
- Lining: polyester taffeta

- Filling: 2.6 lbs (1200 g) of Insufil Thermo
- Zipper: #5 YKK 2-way, reversible puller, auto-lock
- Stuff Sack: cap compression bag
- Total Weight: 5.3 lbs (2.4 kgs)
- 20-2211M..... 206.95



One of the warmest sleeping bags in the Chinook product line, featuring Insufil® Thermo insulation, ergonomic head gasket and foot box, waterproof bottom fabric, oversized draft tubes and neck collar for added protection in the most extreme conditions. The Chinook SnugHood™ design gives the best fit around the facial area providing extra comfort while reducing bulk when the draw cord is fully tightened.

CHINOOK KODIAK EXTREME II SLEEPING BAG

- Temperature Rating: -40°C
- Size: 90" x 34" x 22"
- Shape: mummy
- Construction: four layer shingle design
- Outer Shell: ripstop nylon
- Lining: polyester taffeta

- Filling: 5.3 lbs (2400 g) of Insufil Thermo
- Zipper: #8 YKK 2-way, reversible puller, auto-lock
- Stuff Sack: cap compression bag
- Total Weight: 7.5 lbs (3.4 kgs)
- 20-2213M..... 247.95



CHINOOK POLAR COMFORT SLEEPING BAG

- Temperature Rating: 15°F / -10°C
- Size: 83" x 32" x 20"
- Shape: mummy
- Construction: horizontal channel design
- Outer Shell: ripstop nylon
- Lining: polyester

- Filling: 1.3 lbs (600 g) of 90/10 grey goose down
- Zipper: #5 YKK 2-way
- Stuff Sack: compression bag
- Total Weight: 2.23 lbs (1.0 kgs)
- 20-2201M..... 299.95



CHINOOK YOUNG CAMPER SLEEPING BAG

- Temperature Rating: 0°C
- Size: 65" x 27" x 20", length expands 12"
- Shape: mummy

- Filling: 1.5 lb (700 g) of Insufil 1
- Total Weight: 2.7 lbs (1.23 kgs)
- 20-2221M.....BLUE..... 87.95
- 20-2222M.....RED..... 87.95



CHINOOK TREELINE 4.5 SLEEPING BAG

- Temperature Rating: -10°C
 - Size: 80" x 34"
 - Shape: Rectangular
 - Construction: Two-layer
 - Outer Shell: Nylon
 - Lining: Pongee
 - Filling: 4.4 lbs (2000 g) of Insufil 1
 - Zipper: #5 YKK 2-way
 - Stuff Sack: Standard
 - Total Weight: 6 lbs (1.35 kgs)
- 20-2206M..... 127.95



CHINOOK TREELINE 6 SLEEPING BAG

- Temperature Rating: -20°C
 - Size: 80" x 34"
 - Shape: Rectangular
 - Construction: Two-layer
 - Outer Shell: Nylon
 - Lining: Pongee
 - Filling: 6 lbs (2700 g) of Insufil 1
 - Zipper: #5 YKK 2-way
 - Stuff Sack: Standard
 - Total Weight: 7.6 lbs (3.5 kgs)
- 20-2207M..... 155.95



Get a great sleep in the great outdoors in one of these extra-wide and thermally efficient bags. Practical, warm and affordable, this series is perfect for the outdoorsman who depends on his gear in tough conditions. 2 layers of Insufil® 1 Polyester Hollow Fiber. Poly/cotton Canvas outer shell with comfortable flannel lining. Full length, durable #8 nylon coil 2-way zipper. Comes with water-resistant duffel bag.

TRAILSIDE WOODLAND 8 SLEEPING BAG

- Temperature Rating: -30°C
 - Size: 87" x 42"
 - Shape: Rectangular
 - Construction: two layer
 - Outer Shell: poly-cotton canvas
 - Lining: soft flannel
 - Filling: 8 lbs (3650 g) of Insufil 1
 - Zipper: #8 YKK 2-way
 - Stuff Sack: duffel bag
 - Total Weight: 11.6 lbs (5.2 kgs)
- 20-2218M..... 344.95



These rugged oversized Multi-Season System bags are a perfect choice for any cold-weather hunting or camping trip. They feature our practical 3-in-1 Multi-Season System. 2 layers of Insufil 4 hollow fiber for superior warmth. Zippered hood and liner for easy removal and washing. Outer shell is made of heavy-duty polycotton canvas. Water-resistant duffel bag is included.

CHINOOK ALASKAN 9.5 DOUBLE XL SLEEPING BAG

- Temperature Rating: -45°C
 - Size: 87" x 42"
 - Shape: rectangular with removable hood
 - Construction: 2 detachable insulated bags
 - Outer Shell: heavy duty poly-cotton canvas
 - Lining: soft poly-cotton with detachable flannel liner
 - Filling: outer bag: 6 lbs (2700 g); inner bag: 3.5 lbs (1600 g); total: 9.5 lbs (4300 g) of Insufil 4
 - Zipper: main: #10 heavy duty 2-way; inner: #8 & #5
 - Stuff Sack: heavy duty water-resistant duffel bag
 - Total Weight: 29.8 lbs (13.5 kgs)
- 20-2214M..... 579.95

Use it 3 ways:
 1. 4-season single sleeping bag
 2. Two individual sleeping bags
 3. Extra roomy zip-together 2-person sleeping bag



AMK DAY TRIPPER MEDICAL KIT

The Day Tripper Lite Medical Kit is the ideal resource for a single day in the woods, whether you're exploring solo or with a friend. Ultra-light and perfectly portable. Group Size: 1-2 People. Trip Duration: 1 Day
 Dimensions: 5.5" x 2" x 4"
 See www.mercersmarine.com for detailed list of items.
 50-312M 22.95



AMK HIKER MEDICAL KIT

The Hiker Medical Kit is built for weekend warriors. A must-have companion when you and a friend hit the trail for a day or two, the Hiker is equipped with carefully-selected supplies tailored to meet any basic first aid needs you might experience along the way. The Hiker is as comprehensive as it is compact: blisters, stomach aches, sprains, and wounds won't slow you down for long when you have the lightweight Hiker with you.
 Group Size: 1-2 People. Trip Duration: 1-2 Days
 Dimensions: 6.5" x 3" x 5.5"
 See www.mercersmarine.com for detailed list of items.
 50-313M 36.95



AMK BACKPACKER MEDICAL KIT

The Backpacker Medical Kit is designed for a pair of outdoor explorers on a four-day foray into the wilderness. Outfitted with a handpicked assortment of first aid supplies designed to help your short adventure go smoothly, it contains remedies for a range of conditions—from cuts and allergies to upset stomach and dehydration. Whether you're stretching out your weekend in the woods or embarking on a multiple-night hike, the Backpacker has your back.
 Group Size: 1-2 People. Trip Duration: 1-4 Days
 Dimensions: 7" x 3.5" x 6"
 See www.mercersmarine.com for detailed list of items.
 50-314M 54.95



AMK WATERTIGHT 7 MEDICAL KIT

2-Stage Waterproofing. Inner DryFlex bags and outer seam-sealed siliconized nylon bag with water-resistant zipper. Clean and Close Wounds. Antiseptic wipes and butterfly bandages for closing small wounds. Emergency Repairs. Mini roll of duct tape (2" x 26"). Manage Pain and Illnesses. A wide array of medications to treat pain, inflammation, and common allergies. Stabilize Fractures and Sprains. Wraps and bandages to immobilize fractures and provide support. Stop Blisters before they start. Die-cut Moleskin plus Skin Tac topical adhesive to protect against the hiker's #1 injury. Easy Access Bandages. Fast and easy application and less contamination risk.
 50-307M(6" x 8") 34.95



AMK SOL SURVIVAL KIT

The Scout provides you with everything you need to stay safe, stay warm, and get found in a survival situation. A professional-grade RF-welded waterproof bag keeps contents dry in any conditions. See www.mercersmarine.com for detailed list of items.
 50-302M(3" x 6") 33.95



50' BRAIDED UTILITY CORD

50 feet of heavy duty utility cord suitable for a wide variety of situations. Strong multi purpose woven polypropylene cord. Will not rot or mildew in damp conditions. 8mm diameter.
 20-255M 10.25



www.mercersmarine.com

- Always Open
- Sale & Feature Items
- View Catalogue
- Thousands of products
- Updated Regularly
- Up to date Pricing
- Mobile Friendly
- Shop from anywhere at anytime

find us on

NEW



SOL HEAT REFLECTIVE PONCHO

Made with a high-performance, 90% heat reflective material. Waterproof. The durable material is tear resistant and won't shred like Mylar, giving you an emergency poncho or backpacking poncho you can count on for multiple trips. A great lightweight addition to your backpacking gear and folds up small enough to fit in the side pocket of your backpack. The roomy design can cover you and your pack, making this hooded poncho the ideal ultralight rain gear.
 50-315MOne Size 10.49

NEW



SOL SIGHTING COMPASS WITH MIRROR

The SOL Sighting Compass allows you to take precise navigational readings while keeping your eye on the trail in front of you. For improved accuracy, adjust the declination with the included tool. With inch, millimeter, and ratio measurements on one tool, you can get accurate readings on any map. Use the magnifying glass to identify key waypoints and the glow-in-the-dark features for twilight navigation. Align your adventure with the index lines and orientation lines. Keep around your neck or attach to gear with the included breakaway lanyard.
 50-317M 23.95



SURVIVE OUTDOORS LONGER EMERGENCY BLANKET

Legendary Durability: Resists tearing and will not shred like Mylar blankets. Shelter from the Elements: Heatsheets material is waterproof and windproof. Stay Warm: Reflects 90% of radiated body heat. More than Just a blanket. A true ultra-light multifunction backcountry tool that can also be used as a ground cloth, gear cover, first aid blanket, and more.
 50-310M(56" x 84") 7.49



AMK SOL EMERGENCY BIVVY SHEET

Full Protection: Sealed on the sides for full protection from rain, wind, and snow. Legendary Durability: Heatsheets material is waterproof and windproof. Stay Warm: Reflects 90% of radiated body heat.
 50-306M(84" x 36") 25.95



SURVIVE OUTDOORS LONGER ESCAPE BIVVY

A bivvy that BREATHES: Stay warm AND dry in the original backcountry emergency shelter that stays dry while you heat up. Weather the Elements: Highly water-resistant fabric keeps you dry even in wet, soggy conditions. Stay Warm: Reflects 70% of radiated body heat. All-season Durability: Hard-wearing fabric resists punctures and tears through heavy use. High-visibility orange exterior. Makes it easy for rescuers to spot you even in areas with high tree cover.
 50-309M(84" x 31") 81.95



INSTA-FIRE STARTER

Each pouch will light up to 4 fires. Burns in wind, rain sleet and snow. Lightweight and easily carried anywhere. Burns green, no harmful chemicals or vapours.
 20-193M 8.95/pk of 3



ECO FIRE NUGGETS & STICKS

Quick and effective starter for BBQ's, wood stoves, campfires, smokers and pizza ovens. Made from recycled wood and food grade paraffin wax. Each nugget burns for up to 10 minutes. No more news papers of kindling. No more toxic lighter fuel of gels. No odors. Easy to light. Waterproof.
 20-212MNuggets (Pk of 24) 13.25
 20-215MSticks (Pk of 18) 15.25



PROPANE STOVE AND GRILL

One high output 3.25" 10,000 BTU stainless steel burner. 8,000 BTU BBQ burner. Piezo igniter. Polished stainless steel drip pan for easy cleaning. High pressure/altitude, pressure regulator. Removable grease tray. Uses disposable propane cylinders (not included). Ideal for camping, cottage, trailers, boating, and tailgate parties
 20-067M.....185.95



DELUXE 2 BURNER STOVE

Rated at 20,000 BTUs, 10,000 per burner. Stainless steel easy to clean drip pan. Operates with disposable propane cylinders (not included). Independent control valves for each burner. Enamel coated steel body with built in carry handle. Fold down legs and windshields. Ideal for camping, cottages, trailers, boating, and tailgate parties.
 20-066M.....118.95



DUAL BURNER OUTDOOR PROPANE STOVE

Ultra durable steel construction with dual high-pressure cast iron burners. 55000 BTU total output. Fully adjustable, separate heat control dials. 20 PSI certified regulator with 1.2m tube. Heat and weather resistant coating. Connects to standard 20 lb refillable propane tank (not included). Legs are removable and stow for easy transportation / storage. Adjustable legs to accommodate for uneven ground. Ideal for camping, cookouts, tailgate, cottage, and emergency preparedness. 30.75" x 16" cooking area. 29" adjustable cooking height.
 20-071M.....239.95



SINGLE BURNER CAMP STOVE

7500 BTU burner. Large burner base for stability. Plastic base stand. Uses disposable propane cylinders (not included). Baked enamel finish on steel. Rugged, light and compact. Instant flame adjustment. Adjustable flame intensity. Fits all disposable propane cylinders (Not Included). Display boxed. Weighs only 1.6 lbs.
 20-072M.....50.25



SINGLE BURNER PROPANE STOVE

High output 8200 BTU stainless steel burner. Stainless steel burner support. Adjustable flame control knob. Powder coated steel frame. Brass LP regulator and burner support clip to store under stove. ABS support feet. Uses 1 lb disposable propane cylinders.
 20-286M.....55.50



DOUBLE MANTLE LANTERN

Double mantle adjust to 5,000 BTU output. Heat resistant globe. Enamel hood and chrome plated finish. Enclosed globe for windproofing. Intensity control valve. Folding hang/carry handle. Complete with moulded plastic base. Uses disposable propane cylinders (Not Included).
 20-073M.....55.50



MANTLE TIE-ON (2 PK)

For use with World Famous and other single tie or double tie propane or liquid fuel lanterns.
 20-056M.....3.95



PROPANE REGULATOR & HOSE

Replacement regulator for all World Famous Outdoor Basics Propane Camp Stoves. Propane appliance hose connects traditional bulk propane tanks to camping outdoor appliances. Contains 1 x 5' high pressure hose. CSA/CGA approved.
 20-125M.....Propane Regulator.....35.50
 20-124M.....Propane Hose.....43.95



BACKPACKERS BUTANE STOVE

11,000 BTU polished stainless steel burner. Wind-baffle stainless steel burner grate. Coated brass valve. Nylon carry bag included. Fits self sealing butane/propane fuel cartridges. Fuel sold separately. See below.
 20-288M.....37.25
 20-289M.....Butane /Propane Fuel (4oz).....7.25
 20-290M.....Butane /Propane Fuel (8oz).....8.50
 20-291M.....Butane /Propane Fuel (16oz).....12.95



COMPACT 1 BURNER PROPANE HEATER

3100 btu/h infrared propane heater element. Piezo Igniter. Aluminum heat reflector (no color change after burnt). Chrome steel protection grill. Safety flame failure thermocouple device. Step control setting (hi, med, low, off). Operates on 1-lb propane cylinder (Not Included). Extendable plastic cylinder base.
20-069M68.95



WORLD FAMOUS PROPANE HEATER

11,500 btu/h infrared Propane Heater element. Piezo Igniter. Aluminum heat reflector (no color change after burnt). Chrome steel protection grill. Safety flame failure thermocouple device. Step control setting (hi med low off). Tip over safety shut off device. Operates on 20-lb propane cylinder (not included)
20-070M95.95



STAINLESS STEEL KETTLE

Great little tea kettle. Complete with wire filter basket. Fold down handle. Removable lid.
20-024M 1 Litre33.50



CAST IRON SKILLET

Foundry seasoned, ready to use upon purchase. Use on all cooking surfaces, grills and campfires. Oven safe. Sauté, sear, fry, bake and stir fry to heart's content.
70-1902K6.5"26.95
70-1903K8"41.50
70-1904K10.25"57.75
70-1905K12"76.95



BLACK CAST IRON FRYING PAN

Non-seasoned.
70-2409K16"115.50



2.5 LITRE ENAMEL KETTLE

Rugged and durable. Double high gloss enamel coated steel. Classic style tea kettle. Blue speckled enamel finish. Folding carry handle with spring support.
20-028M2.5 litre 37.50



NATO STYLE CHOW KIT

Heavy guage rugged stainless steel. Contains knife, fork, and spoon. Nestles in can/bottle opener.
20-227M10.25



STAINLESS STEEL COOKWARE SET

Polished S.S. with copper bottom and folding handles. Comprises of 6" fry pan, 1.23 Qt pot with lid, 1 litre pot with lid and 2 plastic cups. Comes with carry bag.
20-098M49.50



**Shop or Browse
Online 24/7
at
mercersmarine.com**



STAINLESS STEEL DISHES

20-093M (Soup plate) 10" dia8.25
20-094M(Plate) 9 1/2" dia8.25



STANLEY LEGENDARY CLASSIC BOTTLE - 20 OZ

This rugged little tank of a bottle is built to withstand anything—dings, dents and even drops—all while preserving the thermal integrity of your favorite beverage. It's slim so you can grip it one-handed, and the leakproof design features a twist-and-pour stopper for better control. There's even an insulated lid that doubles as a cup for drinking.

Dimensions: 3.11"L x 3.11"W x 11.42"H

- 20-4496M.....Green40.00
- 20-4497MBlack.....40.00
- 20-4498MSilver.....40.00



Bottomland

Habitat

STANLEY LEGENDARY CLASSIC BOTTLE - 1.5 QT

Campsite, job site or even in the RV—the iconic style and rugged durability of this bottle means it's made to go anywhere. The double-wall vacuum insulation keeps all your drinks at the ideal temperature and the twist-and-pour stopper allows for a smoother pour. The collapsible handle is made for easy grab-and-go and the insulated lid doubles as a cup for drinking.

Dimensions: 4.7"L x 3.9"W x 14.1"H

- 20-4503M.....Green54.00
- 20-4504MBlack.....54.00
- 20-4650MBottomland Camo.....56.50
- 20-4651M.....Habitat Camo56.50



STANLEY LEGENDARY CLASSIC BOTTLE - 2 QT

This bottle is built big for all your big adventures. Stanley's signature vacuum insulation will keep your coffee hot and your iced drinks cold for up to 2 days. The folding handle allows you to take it anywhere (and prevents it from rolling around in the back of your truck bed, boat or trailer). It's also leakproof, packable and easy-to-pour which makes it a welcome companion at any tailgate or camp out.

Dimensions: 4.5"L x 5.5"W x 14.6"H

- 20-4501M.....Green60.50
- 20-4664MSilver.....60.50
- 20-4502MBlack.....60.50



STANLEY LEGENDARY CLASSIC BOTTLE - 2.5 QT

Keep the adventure going all day, all night, and straight into the next morning. This bottle can hold an entire pot of coffee—or whatever else you may be drinking—keeping it hot or cold for up to 48 hours. It's also leakproof, packable and easy-to-pour which makes it a welcome companion at any tailgate or camp out.

Dimensions: 5.5"L x 4.7"W x 15.6"H

- 20-4499MBlack.....67.00
- 20-4495MSilver.....67.00



TOUGH-TO-TIP ADMIRAL'S MUG - 20 OZ

This retro-inspired mug is made to stay put, no matter where you set it down—truck dashboard, boat console, or even that wobbly desk in your office. The wide base and non-skid bottom are designed for stability, while the double-wall vacuum insulation keeps drinks hot or cold longer. There's even a leak-resistant flip lid that locks in place for security.

Dimensions: 4.88"L x 6.57"W x 5.59"H

- 20-4507MBlack.....40.00
- 20-4508MGreen40.00



FAST FLOW WATER JUG - 2 GALLON

Job site, campsite or even on the soccer field—this mega-sized 2-gallon jug is great for group gatherings. A rugged handle and leak proof design means you can take it anywhere and the double-wall foam insulation will keep drinks cold for hours (iced for 2 days). The high-flow spigot also removes easily for cleaning.

Dimensions: 11.69"L x 11.69"W x 13.5"H

- 20-4519MBlack.....67.50
- 20-4520MPolar.....67.50



COLD FOR DAYS OUTDOOR COOLER - 30 QT

Long weekends and epic road trips have met their match. This cooler can keep your food and drinks cold for 4 days, even under sweltering conditions. The durable, leak-free design and extra height is built to accommodate 2-liters, longnecks, fifths, and magnums so everything fits comfortably and stays protected. Close it up and use the top as a table, step stool, or seat. Dimensions: 21.34" L x 15.47" W x 18.46"

- 20-4522M.....Green214.50
- 20-4520MBlack.....214.50



EASY CARRY LUNCH COOLER - 7 QT

When you need a cooler that can keep its cool for a full day, then this is the cooler for you. Pack lunch for two and take it on a scenic hike, a picnic in the park or to an all-day festival. It's leakproof, easy-to-carry and comes with an adjustable bungee system for securing your favorite Stanley bottle to the lid.

- Dimensions: 13.3" L x 11.1" W x 8.6" H
- 20-4529M.....White65.00
 - 20-4530M.....Green65.00



EASY CARRY OUTDOOR COOLER - 16 QT

Ruggedly lightweight, leakproof and boasting more than twice the foam insulation of a typical cooler, this cooler is ideal for tailgates, fishing trips and even all-day festival festivities. It's roomy enough to hold 21 cans of your favorite brew or soda and can keep ice frozen for over a day. There's even an adjustable bungee system for securing your favorite Stanley bottle to the lid. Dimensions: 16.73" L x 12.8" W x 11.22" H

- 20-4531M.....Blue104.00
- 20-4532M.....Green104.00
- 20-4533M.....White104.00



CLASSIC LUNCH BOX - 5.5 QT & 10 QT

As far as vintage lunch boxes go, this one's a real classic. Timeless design. Durable construction.

5.5 QUART

This compact lunch box has a metal bracket that will hold your 16oz Stanley Trigger-Action Travel Mug or Vacuum Bottle in place.

- Dimensions: 10.4" L x 4.9" W x 8.4" H
- 20-4665M.....Green52.00

10 QUART

Enough room to hold all your food. There's even a metal bracket just inside the lid that can keep your full-size Stanley Vacuum Bottle or Mug secure.

- Dimensions: 12.99" L x 6.5" W x 10" H
- 20-4666M.....Green52.00
 - 20-4667M.....Black.....52.00



HERITAGE COOLER & BOTTLE SET

Looking for a better way to pack lunch? This classic combo ensures that soups stay hot and sandwiches won't get squashed or soggy. The sectioned interior is designed to keep multiple courses cool and organized. And the cooler handle locks the 1.5 qt. Stanley Classic Vacuum Bottle in place. When you're ready to eat, the reversible lid also doubles as a lunch tray.

- Dimensions: 16" L x 9" W x 13" H
- 20-4537M.....100.00



CAMP MUG - 12 OZ

There's a reason we call this mug Legendary. It's made tough with Stanley's double-wall vacuum insulation, so your favorite drinks stay hot or cold longer. The secure press-fit Tritan™ lid also prevents splashes so you can sip easy in the kitchen, on the job, or around the campfire. Dimensions: 4.7" L x 4" W x 4.3" H

- 20-4542M.....Green30.00
- 20-4543MBlack.....30.00
- 20-4659M.....Rose30.00



ALL-IN-ONE FRY PAN SET

Burgers, pancakes, scrambled eggs or stir fry, this 9-piece set is made to cook up anything on your menu. Designed with superior 3-ply construction, the fry pan performs as well as your favorite kitchen pans for more even heating. There's also a cutting board, collapsible spatula and trivet for food prep, plus a two-person place setting to serve and eat. Pan is 7.5" Diameter.
20-4534M.....52.00



CLASSIC LEGENDARY FOOD JAR & SPORK - 14 OZ

This on-the-road or at-the-campsite food jar has all the bells and whistles. Compact—but with plenty of room for your favorite hot or cold recipe. An insulated lid with a pressure-release valve for easy opening. And last but not least, a stainless-steel spork that fits securely into the attached bracket on the side. Bon appetite!
20-4613M.....Green33.50
20-4614MBlack.....33.50
20-4615MClay.....33.50



LEGENDARY USEFUL LUNCH BOX - 1.25 QT

Ideal for securely carrying your sandwich lunch and a snack for long days on the job. The name says it all – our Useful Box also holds all your treasures and supplies for you to take anywhere. Everything from jewelry-making materials, seeds for the garden, or your child's sticker collection. Versatile, compact, and made with the same durable, easy-clean stainless steel that you expect from Stanley Classic gear.
20-4642M.....Green45.50
20-4643MSilver.....45.50



FULL KITCHEN BASE CAMP COOKSET

Take your camp kitchen to the next level. This 21-piece cookset packs all the convenience of a fully stocked kitchen into a package that is perfect for tiny homes, dorm rooms, campsites and #vanlife. The stainless steel pot and 3-ply fry pan are built to perform like pros, ensuring that food heats more evenly. With all the tools needed to prep, cook, serve and clean up, you may even keep this set in your kitchen for everyday use.
20-4535M.....117.00



CLASSIC STAY HOT FRENCH PRESS - 48 OZ

Great coffee is meant to be shared and this large capacity French press can brew enough for your whole crew. There's a stainless steel mesh filter to keep grounds in place so you get a bold, full-flavored cup of coffee with minimal sediment. Vacuum insulation also keeps everything piping hot until the moment you're ready to pour. Built rugged for the outdoors, but so good you'll probably use it at home daily.
20-4616M.....Green91.00



CLASSIC STAY CHILL BEER PITCHER SET

From RV adventures to camping trips to backyard BBQs, this versatile, stainless-steel set is right at home. Fill the vacuum-insulated pitcher with cocktails, mocktails, iced tea, or even hot cider. The rugged handle and pour-through lid make for easy serving into the matching pint glasses. Cheers!
20-4641M.....Green97.50



STAY HOT CAMP CROCK - 3QT

Fill it, pack it, and take it on the road to Adventure. This durable camp crock is leakproof, vacuum insulated and easily perfect for soups, pasta, BBQ or whatever you need to keep piping hot. Since it works with cold foods too, it also makes a great ice bucket. Dimensions: 8.7"L x 8.7"W x 9.4"H
20-4538MShale.....91.00
20-4539MStainless Steel.....91.00



CLASSIC PERFECT-BREW POUR OVER

For those who take their coffee seriously, The Perfect-Brew Pour Over is, well, perfect. It features an easy-to-clean filter you can use, remove and reuse, no disposable filters needed. Just spoon in your favorite medium-ground coffee, saturate with hot water, and let the pour over do the rest. Made to work with most Stanley mugs and bottles.
20-4617M.....Green30.00
20-4660MBlack.....30.00



CLASSIC PERFECT-BREW POUR OVER SET

This stainless-steel coffee maker includes a stainless-steel filter and a matching Camp Mug for brewing the perfect cup. No paper filters needed, thus providing your loved ones with sustainable coffee-brewing gear!
20-4640M.....Green52.00
20-4661M.....White52.00

Kelly Kettle



Trekker
0.6 Litres

Kelly Kettle



Scout
1.2 Litres

Kelly Kettle



Base Camp
1.6 Litres

Kelly Kettles

KELLY KETTLES

Food Grade Stainless Steel (304). Our Steel Kettles are laser and spot welded with No Rivets (new model). All kettles come with a durable stainless steel fire-base, drawstring carry bag. Kelly Kettles are available in 3 sizes.

Stainless Steel

20-930K.....Trekker99.95

Stainless Steel

20-932KScout112.95

Stainless Steel

20-934K.....Base Camp119.95



Cookset
(Available in Small or Large)



HOBO STOVE

Place this Hobo Stove accessory on to the fire base of your 'Base Camp' or 'Scout' Kettle to create a highly effective wood fired Camp Stove.

20-937KSm (Trekker)21.95
20-938KLg (Basecamp & Scout)23.95



KELLY KETTLE PLATE/BOWL SET

Made from 0.5mm Food Grade 304 Stainless Steel. 2 x stainless steel plate/bowls. Overall Diameter 197mm / Height 30mm. Each plate/bowl weighs 0.125 kg. Dishwasher Safe. Stackable, Durable and tough. Suitable for outdoor or indoor use. Rim around the edge protects fingers from getting burned when plate contents are hot. Can be used as a Pan for cooking.

20-939K.....31.95



Pot Support

Accessories

20-936KPot Support.....12.95
20-945KSmall Cookset (50042)27.95
20-946KLarge Cookset (50041)31.95



KELLY KETTLE SPORK

Grey, Red, Light Blue, Green, Blue and Orange. Material: Polypropylene (Plastic). BPA Free. Maximum Operating Temperature 120 Celsius. Dishwasher Safe.

Length 16.3 cm

20-960K.....Orange1.95
20-961K.....Blue1.95
20-963K.....Grey1.95
20-964K.....Green1.95



KELLY KETTLE MUG SET

2 x High quality single walled Camping Cups (350 & 500ml). Silicone coated foldable handles for comfort. Coolip feature (removable) to protect lips from burning. Measurements on side of cup. Polished internally for easy cleaning. Dishwasher safe / Pack together.

20-951K.....31.95



KELLY KETTLE ULTIMATE BASE CAMP KIT

Kelly Kettle Ultimate Kits are the best value when purchasing Kelly Kettle products! This Kit includes:

- 'Base Camp' Kettle
- Hobo Stove
- Cook Set
- 2 x Cups
- 2 x Plates
- Base/Pot Support
- Storage Bag

All items are Stainless Steel and fit neatly within the kettle itself and/or the carry bag for transport / storage.
20-953K.....215.95



KELLY KETTLE ULTIMATE SCOUT KIT

Kelly Kettle Ultimate Kits are the best value when purchasing Kelly Kettle products! This Kit includes:

- 'Scout' Kettle
- Hobo Stove
- Cook Set
- 2 x Cups
- 2 x Plates
- Base/Pot Support
- Storage Bag

All items are Stainless Steel and fit neatly within the kettle itself and/or the carry bag for transport / storage.
20-954K.....205.95



KELLY KETTLE TREKKER BASIC KIT

This Trekker basic kit contains:

- Trekker Kettle (0.6 liter)
- Cook set
- Frying Pan
- 2 Piece Grill
- Gripper Handle.
- Pot/Fire-Base Support
- Storage Bag

20-955K.....155.95



The most reliable ultra-fast camping kettle for the outdoors!

- Kelly Kettles for Camping, Picnics, Scouts, Fishing, etc.
- NO Batteries, NO Gas - FREE FUEL! Works with any fuel: sticks, dry grass, bark, pine cones, even dry animal dung!
- In Stainless Steel or Aluminum
- No open fire (the fire is contained within the kettle & fire base).

- Lightweight, compact, durable & works in extreme weather.
- Excellent customer service
- Camping Equipment For Wilderness Survival, Emergency Preparedness or Disaster Kits
- Carbon neutral green camping.
- No travel restrictions (planes etc.)
- 3 sizes available (1.5ltr / 1.1ltr / 0.57ltr)
- Boil water & cook at the same time!



RIDGELINE STAINLESS STEEL DUO COOKSET

Premium quality stainless steel cookset made from very sturdy 18/8 polished stainless steel perfect for any camping trip. Perfect for 1-2 persons. Lightweight and extremely durable. Cookset nests into a compact package. Dishwasher safe. Copper-reinforced bottoms. Includes a carry bag for clean storage

Contents: 1 qt. pot with lid. 1.5 qt. pot with lid. 6" frying pan with folding handles. 2 plastic mugs. Nylon stuff sack.

20-2300M.....66.95



RIDGE HARD ANODIZED NON-STICK COOKSET

This unique line of lightweight and extremely durable cookware features hard anodized aluminum construction, making camp cooking a breeze. Perfect for campers, mountaineers, backpackers and paddlers.

Lightweight, extremely durable cookware with great heat conduction. Non-stick, easy-clean coating on the interior of the pots and frying pan. All components nest together into a compact package. Contents: 1 qt. pot with folding handles. 1.7 qt. pot with folding handles. 7" frying pan with folding handles. Nylon stuff sack.

20-2301M.....82.95



PLATEAU DEEP PLATE

Super durable, high quality 18/8 stainless steel plate is a versatile addition to your camp kitchen. Diameter: 8.5"

20-2304M.....12.95



TREELINE STAINLESS STEEL CUTLERY SET

Made of super-tough, rustproof stainless steel with a convenient detachable ring.

20-2305M.....9.95



KEROSENE LANTERNS

Safe for outdoor/indoor use. Metal construction. Cotton wick adjusts for light intensity. Throws bright light.

20-470R9-1/2" Model13.95

20-473RSmall Wicks for 9 1/2"2.95 /6 pk.

20-471R12" Model16.95

20-079R.....Replacement globe for 12"5.95

20-474RSmall Wicks for 12"3.95 /6 pk



TIMBERLINE MUG WITH FOLDING HANDLES

This lightweight, compact single wall mug is made of high quality stainless steel great for hikers and travelers. Size: 10 fl. oz

20-2303M.....10.95



TIMBERLINE S.S. COFFEE PERCOLATOR

The Timberline Coffee Percolator with its heavy gauge 18/8 polished stainless steel construction and heat insulating Permawood handle makes perfect coffee at picnics, camp and home. This percolator has precision-fitting, seamless parts for brewing great coffee for years to come. Dishwasher-safe. Includes a quality storage sack with a drawcord closure.

20-2306M3 Cup54.95

20-2307M6 Cup64.95

20-2308M9 Cup77.95

20-2309M12 Cup88.95



13" GLASS OIL LAMP

70-037K.....27.95

Replacement Burner & Wick

20-052K.....3"6.95

Lamp Wick

20-044R.....3/4"0.60/ft

20-041KReplacement Globe7.95



LED CRANK UP LANTERN

Battery free crank lantern provides super bright illumination. 12 super bright LED bulbs last up to 80,000 hours. Push button on and off switch. Four illumination modes, OFF- 4 LED- 8 LED-12 LED. White colour LED's cast a 360 degree glow. Top handle hook for easy hanging. Built in compass.

20-140M.....34.25



LED TAK-LITE FLASHLIGHTS

CREE® XRE-Q5 bulbs for maximum brightness. Machined aluminium alloy body. Shock proof and temperature resistant. Extra- large lens. Push button On-Off switch. Attached Lanyard. Batteries not included. Available in 4 sizes.

Tak-Lite 2C Uses 2 x "C" batteries 120 Lumens
20-089P.....8 1/4" Length.....28.95

Tak-Lite 3C Uses 3 x "C" batteries 200 Lumens
20-090P.....9 3/4" Length.....31.95

Tak-Lite 2D Uses 2 x "D" batteries 130 Lumens
20-091P.....10 1/8" Length.....31.95

Tak-Lite 3D Uses 3 x "D" batteries 220 Lumens
20-092P.....12 1/4" Length.....37.50



RWD TAK-LITE 600 LANTERN

36 SMD high-output LED bulbs. Max output: 600 Lumens. 4 light settings: 100% - 80% - 50% - 20%. Uses 4x "D" batteries (not included). **Approx 10"H x 5" Dia**
20-269M.....42.50



- Always Open
- Sale & Feature items
- View Catalogue
- Thousands of products
- Updated regularly
- Up to date pricing
- Mobile friendly
- Shop from anywhere at anytime

www.mercersmarine.com

NEW



4 IN 1 EMERGENCY RADIO/FLASHLIGHT

Cranking 1 minute will power light for up to 30 minutes. 3 super bright LED bulbs last up to 80,000 hours. Three illumination modes, off, 1 LED and 3 LED's. AM and FM radio tuner with pull out antenna. Alarm mode, sends off a loud siren. Wrist strap for comfortable carrying. **Approx 7.5"H x 2.25"**

20-904M.....43.95



RWD TAK-LITE 250 LANTERN/SPOTLIGHT

1 x 3WATT+ 12 SMD high output LED bulbs. Spotlight/ Floodlight functions. Max output: Spotlight – 250 lumens, Floodlight-140 lumens. Uses 3 X AA batteries (not included). Folding Handle. Handle length: 5.3"
20-271M.....30.50



COAST
LIGHTS • BATTERIES • MULTI-TOOLS

NEW



COAST EAL 13 AREA LANTERN

The EAL13 has a 330-lumen output on high and will run for 120 hours on low. The EAL13 is rated IPX4 storm proof and built for any situation, with a tough, drop-proof nylon body and polycarbonate dome and globe construction. Users can remove the globe to allow for higher lumen output – and with carabiners on the top and bottom, the lantern can be hung to provide overhead lighting. The EAL13 features magnets on the underside of the lantern to affix to metal surfaces, as well. Width 2.5" x Length 2.5" x Height 6.22" .

(D batteries not included)

20-3518P38.95

COAST
LIGHTS • BATTERIES • MULTI-TOOLS

NEW



COAST EAL 17 AREA LANTERN

The EAL17 Lantern is a great stainless steel designed lantern that can either illuminate your space or alert people in times of need. Cycle between high, low, solid red, and flashing red modes to best suit your situation.

Light Output (High) 460 Lumens. 9.9" Height.

(4 x D batteries not included)

20-3516P48.95

COAST
LIGHTS • BATTERIES • MULTI-TOOLS



COAST FL19 HEAD LAMP

Features a dual-colour function; all-white utility beam for general use, and a red, anti-glare beam that prevents "night blinding". Features an emergency signaling tool. Hardhat compatible. Dual power function to save battery. Features a hinged, tilting head. Water resistant. Reflective strap increases safety and ensures visibility in low light. Runs on 3 x AAA.

20-3504P32.95

COAST
LIGHTS • BATTERIES • MULTI-TOOLS

NEW



COAST EAL 22 AREA LANTERN

This 9.13" High x 4.21" Diameter lantern delivers up to 1300 lumens of white light, with a secondary red LED that can be used as a flashing emergency signal or a work light that won't disrupt your night-acclimated vision. The lamp's diffusing globe creates a soft light, but it can be removed when you need more brightness. A simple push button on the side cycles through the settings. The plastic housing is IPX4-rated splash resistant and features carabiners on the top and bottom and a folding handle for hands-free use.

(D batteries not included)

20-3519P66.95



COAST FL13 HEAD LAMP

The FL13 is a compact LED headlamp with high and Low light outputs. This headlamp casts a wide beam and is handy for up-close work. Also includes a solid and flashing red LED light feature. The red LED light beam help to prevent night blindness. Impact resistant, weather resistant and its LEDs are virtually unbreakable.

20-3507P24.95

COAST
LIGHTS • BATTERIES • MULTI-TOOLS



COAST FL60 HEAD LAMP

The FL60 Canada Headlamp is impact resistant, weather resistant and its LED is virtually unbreakable. Equipped with our Wide Angle Flood Beam, this headlamp is perfect for illuminating large areas with its ultra-wide circular beam. A conveniently located button on the front of the headlamp allows the user to swiftly change between high, medium, and low light outputs. The headlamp comes with an IPX4 weatherproof rating and reflective safety strap.

20-3505P45.95



COAST XP SERIES HEAD LAMP

Shine bright and stay hands-free with the workhorse in our XPH professional headlamp series. This headlamp's dust-resistant and storm proof aluminum body rolls in its bracket for dynamic directional lighting and can also detach to become a handheld flashlight with a built-in magnetic tail cap and real-time power indicator. Transitions between Ultra View Flood Beam and Spot beam. Featuring COAST's Rechargeable Dual Power system for versatility on the job, the headlamp runs on a COAST ZITHION-X rechargeable battery (charging cable included.)

20-3508PXPH25R (410 Lumens)57.95

20-3509PXPH30R (1000 Lumens).....79.95

COAST POLYSTEEL FLASHLIGHTS

The Polysteel Flashlights are waterproof, drop proof, and crush proof while possessing the Pure Beam Optics System with twist focus to make the light ultra durable and ready to weather any storm. Stainless steel core and a poly outer.



COAST POLYSTEEL 200 FLASHLIGHT

Light Output (High) 390 Lumens
Light Output (Low) 57 Lumens
Beam Distance (High) 436 ft
Beam Distance (Low) 164 ft
Runtime (High) 4 Hours
Runtime (Low) 36 Hours
Length 5"
20-3510P28.95



COAST POLYSTEEL 400 FLASHLIGHT

Light Output (High) 440 Lumens
Light Output (Low) 60 Lumens
Beam Distance (High) 688 ft
Beam Distance (Low) 246 ft
Runtime (High) 3 Hours
Runtime (Low) 29 Hours
Length 5.75"
20-3511P38.95



COAST POLYSTEEL 600 FLASHLIGHT

Light Output (High) 740 Lumens
Light Output (Low) 100 Lumens
Beam Distance (High) 872 ft
Beam Distance (Low) 337 ft
Runtime (High) 4 1/2 Hours
Runtime (Low) 37 Hours
Length 7.87"
20-3512P44.95



COAST POLYSTEEL 600R FLASHLIGHT

Impact resistant and waterproof. Tested and rated to ANSI/FL1 standards. Pure Beam Optic System allows for good visibility in all types of weather.
Light Output (High) 530 Lumens
Light Output (Low) 42 Lumens
Beam Distance (High) 685 ft
Beam Distance (Low) 193 ft
Runtime (High) 5 Hours 45 min
Runtime (Low) 35 Hours
Length 10.2"
20-3517M65.95





COAST HX5R POCKET LIGHT

The HX5R is the perfect rechargeable flashlight for everyday carry. A USB insert found in the tail cap can be used with USB, AC & DC adapters. The Dual Power system allows the light to run on our custom rechargeable battery and a standard C123 alkaline battery. The light also features a two-way clip that makes it easy to clip in either direction on your pockets or even the bill of your hat. Using our Pure Beam Focusing System with Slide Focus, this light can easily transition from flood to spot modes with one hand.

4" in Length.

20-3520P32.95



**Shop or Browse
Online 24/7
at
mercersmarine.com**





COAST G20 PENLIGHT

Whether you store it in your shirt pocket, pants pockets or a tool bag, the G20 Flashlight with its Inspection Beam Optic is a light that you should keep close. Optimized for up close use with its crisp edges and low glare, the perfectly circular beam illuminates where and when you need it. With Coast's commitment to quality, the G20 Flashlight is impact resistant, weather resistant and its LED is virtually unbreakable. Runs on 2 AAA batteries. 5.7" in Length.

20-3521P19.95





COAST G22 PENLIGHT

Features a fixed BULLS-EYE Spot Beam and pocket clip to combine clip-and-carry convenience with longer-range viewing. Maxing out at 100 lumens, the two-mode beam from this sleek frame reaches 55 meters with a hotspot at the center and a surrounding halo of softer light to expand the viewing area. The G22 measures 4" long and less than one ounce. Combining ultimate portability with ultra-durable construction. Made from top-grade aluminum, this go-everywhere pen light is IP54 storm proof and dust resistant.

20-3522P17.95





COAST G26 PENLIGHT

The G26 flashlight is perfect for the truck, kitchen drawer, or nightstand. Shining 350 lumens with a beam length of 136 meters on high. The BULLS-EYE Spot Beam shines bright with a piercing center and surrounding halo of softer light for an expanded viewing area. The G26 runs over 20 hours on a single set of batteries (2xAAA). Diamond-pattern texturing for better grip. Just over 6" long but built from top-grade aluminum, this flashlight is stormproof and dust resistant.

20-3523P28.95

COAST
SERIES - MARINE - HD-1000000

NEW



COAST XP6R RECHARGEABLE FLASHLIGHT

At less than 4" long and only 2.6 oz, the COAST XP6R flashlight delivers brightest-in-class light, travels anywhere, in a pocket, in a cup holder, or strung from a lanyard, and features patented SLIDE FOCUS optical technology that transitions seamlessly between Ultra View Flood Beam and BULLS-EYE Spot Beam. With three output modes and multi-beam capability, this Rechargeable Dual Power tiny giant is powered by a rechargeable battery (charging cable included).

20-3524P45.95

COAST
SERIES - MARINE - HD-1000000

NEW



COAST XP9R RECHARGEABLE FLASHLIGHT

5.12" in length, The COAST XP9R delivers brightest in class light, peaking at 1000 lumens with three output modes and multi-beam capability. Featuring Rechargeable Dual Power technology, this flashlight is powered by a rechargeable battery (charging cable included). Patented SLIDE FOCUS optical technology ensures you can meet the moment with flawless transitions between Ultra View Flood Beam and BULLS-EYE Spot Beam.

20-3525P69.95

COAST
SERIES - MARINE - HD-1000000

NEW



COAST XP11R RECHARGEABLE FLASHLIGHT

5.98" in length, The COAST XP11R showcases how power meets performance, delivering ultra-bright light and four-mode, multi-beam capability at up to 2100 lumens on Turbo Mode—bold enough for midnight searches but weighing in at less than 6 oz. IP54 dust-resistant and storm proof flashlight is powered by a rechargeable battery (charging cable included) but can also run on standard alkaline AAA's (sold separately). COAST-patented SLIDE FOCUS optical technology shines the Ultra View Flood Beam and BULLS-EYE Spot Beam with seamless transitions at up to 220 meters.

20-3526P89.95

COAST
SERIES - MARINE - HD-1000000

NEW



COAST XP18R RECHARGEABLE FLASHLIGHT

10.3" in length, the COAST XP18R has four-mode, multi-beam capability shining up to a staggering 3650 lumens on Turbo Mode. Featuring COAST Rechargeable Dual Power technology, this IP54 dust-resistant and storm proof powerhouse runs on a rechargeable battery (charging cable included) or standard alkaline AA's (sold separately). COAST-patented SLIDE FOCUS optical technology shines the Ultra View Flood Beam and BULLS-EYE Spot Beam with seamless transitions between.

20-3527P146.95

COAST
SERIES - MARINE - HD-1000000

NEW



COAST CL40R RECHARGEABLE CLAMPABLE LIGHT

The COAST CL40R Clamp Light packs bold power into precision task lighting. An impressive 3900 lumens from its Wide Angle Flood Beam. Featuring a high-strength aluminum clamp and bigger light body, this rock-solid work light attaches firmly to a wide variety of supports. The clamp also doubles as a dynamic stand when rested on a flat surface. Once in place, the light rotates up to 360 degrees and tilts up to 115 degrees for the ultimate in lighting control. CL40R runs on a built-in ZITHION Rechargeable Battery, the CL40R can also be continuously run using standard AC/DC power. To continuously run the CLamp Light, plug the USB-C cable (included) into the Clamp Light and plug the cable into an available power source. Constructed of top-grade materials, the CL40R is rated IP54 for water resistance.

20-3529P159.95

SHOP 24/7 FROM THE COMFORT OF YOUR OWN HOME

- Up to date Pricing
- New Products
- Stock Status
- Additional product info
- And more



www.mercersmarine.com

Flashlights & Lanterns

OUTDOOR RECREATION



LONG BURN EMERGENCY CANDLE 2/PK

Each candle burns 8-10 hours.

20-149M 4.95



WRIST COMPASS

Waterproof and impact resistant, liquid filled compass with luminous dial. Adjustable strap.

20-621M 4.50



SIGNAL MIRROR

Highly reflective 1/4" (6.3 mm) laminated glass. Unique Sight-Grid Retro-Reflective Mesh Targeting System for pinpoint aiming accuracy. Dimensions: 2" x 3"

20-2006M 12.95



BEAR BELL WITH CARABINER

The carabiner attaches in seconds to a pet collar, backpack or belt to jingle as you go, and warn bears or other critters of your presence. The attached mesh storage pouch has a sewn-in magnet to silence the bell when not in use.

20-2056M 3.95



COGHLANS CITRONELLA CANDLE

Imbued with the pleasant aroma of citronella, the handy emergency candle has a burn time of 16-18 hours.

Weight: 3.5 oz. (98 g).

20-2060M 6.95



COMPASS THERMOMETER

Two handy outdoor instruments in one. Liquid filled compass with luminous dial. "Homefinder" instructions on package. Thermometer features °F and °C scales. Belt clip and lanyard included.

20-622M 9.50



FOUR FUNCTION WHISTLE

Compass is ideal for reading a map or orienteering. Whistle is loud enough to alert others of your presence. Thermometer accurately tells the temperature in both °F and °C. Magnifier is useful for reading maps or viewing details on items. Easily attaches to a zipper for quick and easy access. Assorted Colours.

20-2036M 5.50



EMERGENCY BAG

Providing shelter against wind and rain, this bag aids in body heat retention ideal for the prevention and treatment of hypothermia. Size: 84" x 36"

20-559M 5.50



MAP COMPASS

This easy-to-use map compass features a see-through base with a rotating, liquid-filled housing. The scales include inches, millimeters, and 1:25,000 readings. In addition, the jeweled needle and luminous pointer make it easy to navigate using your maps even in low-light conditions. Whether you're a novice or experienced adventurer, this map compass will help you find your way through any terrain.

20-160M 6.50



MOSQUITO COILS

Kills and repels mosquitoes. Each coil will burn six hours or more. Active ingredient: 0.23% d-cis trans allethrin. Contains: 10 coils, two metal stands

20-325M 3.50

MOSQUITO COIL HOLDER

The easy, convenient way to burn Mosquito Coils. Glass fiber nets hold coil firmly and allows coil to burn totally.

20-327M 6.50



EMERGENCY SURVIVAL HORN

The Coghlans' Emergency Survival Horn is so loud it can be heard up to a mile away! It operates with the simplicity of a mouth horn and blasts out audible sound up to 120 dB. Featuring a stone and twig guard to protect the rubber membrane, it also includes a break-away lanyard. The blaze orange color allows it to be easily seen and it also floats.

Diameter: 1.75", length: 3"

20-705M 3.95



PICNIC TABLE COVER

Fits standard 6-foot picnic tables. Durable and easy to clean. Made of ripstop polyester. Packs into attached carry bag. Quick setup with drawstring cinching system. No table clamps required. Reusable and built to last. Dimensions: 76 in. x 37 in.
 20-2084M.....22.95



PACKING CUBES

Made of grey rip-stop nylon, these packing cubes are designed to help keep your luggage and gear organized. Each Packing Cube can either double in size for storing more gear or be compacted to save space, using the expansion zipper that wraps around the side. The front panel is made from breathable mesh to keep your clothes or gear from getting musty. Available in 3 sizes.
 20-2038MSm (8" x 10" x 5" Expanded)16.95
 20-2039M ...Med (10" x 12" x 5" Expanded)18.50
 20-2040MLg (10" x 15" x 6" Expanded)21.50



TENT LIGHT

This bright 120 Lumen LED provides 360° light diffused through a soft silicone lantern shell. With up to 40 hours of run time and 4 brightness levels the Tent Light will cast a comfortable glow inside a tent or around the picnic table. Made from a durable silicone material so that it can survive bumps and falls.
 20-2017M.....20.95



LEATHER WINE SKIN 1 LITRE

The traditional Spanish wine skin made with a rugged leather exterior. Features a heavy poly lining and a braided shoulder strap.
 20-099M.....15.95



COLLAPSIBLE WATER CONTAINER

The 5 Gallon Collapsible Water Container provides a convenient way to transport and use water wherever you need it. The convenient on/off spigot is removable, so it's easy to fill. The Carrier's molded handles make for easy carrying. When empty, the Carrier folds flat for easy transport and storage.
 •On/Off spigot removes easily for quick filling
 •Opening is large enough for ice cubes
 20-031M.....21.95



PICNIC TABLECLOTH

Made from food safe polyethylene, these picnic tablecloths are easy to wipe clean and feature sewn-in edges to prevent ripping or tearing.
 Size: 54" x 72"
 20-319M.....5.50



COGLANS EGG HOLDERS

Perfect for short hikes, these egg carriers are made from virtually unbreakable plastic that won't crush. Molded handles make for easy carrying.
 20-372M.....6 pc.4.50
 20-374M.....12 pc.4.50



CAST IRON DOUBLE BROILER

Pre-seasoned cast iron for cooking over the heavy heat of campfires or barbecues. The open slots on each side of these broilers let grease escape. Removable handles make it easy to take apart and reassemble for simple cleaning and convenient storage. Handle Length: 20.4" Weight: 4.5 lbs. Complete length with handles: 26.3"
 20-150M31.95



COUGLANS "CAMP GRIDDLE" TEFLON

Coated heavy gauge aluminum griddle features a non-stick surface for easy clean up. Extends over two burners of most camp stoves providing adequate room for making a full course breakfast – the outdoors way! Size 16-1/2" x 10" (41.9 x 25.4 cm)
 20-321M.....36.95



TARP CLIPS

These tarp clips are constructed from a durable nylon resin, they grip harder as more weight is exerted onto the clip jaws. Ideal for securing tarps and tents, they can support up to 240 lbs. of resistance. 2/package
 20-606M.....3.95



CAST IRON GRIDDLE

Great for cooking on stoves or open fires. Made of pre-seasoned cast iron Weight: 7.25 lbs. Double-sided: grill, and skillet. Dimensions: 17.9" x 8.9"
 20-146M.....36.95



TRI-POD GRILL HANGER

Ideal for cookouts, this grill can be placed anywhere. Its stable height adjustable grill surface is supported by a 3pc. galvanized steel tri-pod. The legs are shock-corded together and collapse for easy storage.
20-151M47.95



BROILERS

Great for steaks, chops, fish, hamburgers, toast or "KIPPERS" •Chrome plated steel •Hinge design with locking ring.

Standard broiler

29" overall length, grill is 8" x 9" x 1".

20-102M 13.95

Deluxe broiler

26" overall length, grill is 9" x 13" x 1".

20-103M 17.95



TELESCOPING FORK

Chrome plated shaft extends to 34"(86 cm) Wooden handle with thumb roller rotates food to cook evenly.
20-607M 4.95



CAMP COOKER 26"

Toasts sandwiches, grills meat and makes awesome pie-filling desserts all over an open fire. The Camp Cooker is made from lightweight cast aluminum with a two part hinge. Easy to clean with the non-stick finish.
20-018M21.95



41" CAMP FORK

Heavy-duty chrome plated steel camp fork with stay cool wooden handle.
20-557M 4.95



HEAVY DUTY CAMP GRILL

This heavy duty camp grill is ideal when using cast iron cookware. The heavy gauge metal frame and iron mesh grill surface is supported by sturdy legs that fold underneath when not in use. Ideal for snowmobiling.
20-469M24" x 16" 50.95



CAMP GRILL

Heavy duty steel construction, nickel plated. Folding design.
20-100M24" x 12" 23.95



CAMP STOVE TOASTER

Steel Construction, won't warp •Coated wires, won't rust
•Toasts up to 4 slices •9" dia.
20-101M 5.50



EXTENSION FORK

•Chromed wire •Handle extends from 20" to 30" •Ideal for cooking over open fires •Snowmobilers love this item.
20-104M 2.95



TOASTER FORKS

Family pack of four - 20" (51 cm) chromed wire toaster forks.
20-575M 3.95



COGHLANS 18" MACHETE

Polished, high carbon spring steel blade. Rugged plastic handle. Heavy duty Cordura Nylon sheath.
22-104M.....12.95



21" FOLDING SAW

Rugged anodized aluminum frame holds extra blades and is safe and compact. Standard 21" (53.3 cm) wood, meat or metal cutting blade can be added.
20-107M.....45.95



FOLDING SHOVEL

Tempered forged steel blade with metal handle and shaft. Positive locking collar. 23".
20-195M..... 15.95



COGHLANS SIERRA SAW

Tempered flexible steel blade cuts smooth and clean. Locking blade with unbreakable handle.
20-558M.....7-1/2" Blade.....13.50



POCKET SIERRA SAW

The unique One-Touch Lock System ensures the blade is securely locked open when in use. Comfortable grip is slip-resistant and the blade folds into the handle for safety when carried or stored. Blade length: 4". Weight: 2.7 oz. Overall length: 8.5"
20-2065M.....10.95



FOLDING COOK STOVE

Folds for easy carrying. Burns camp heat fuel below or a solidified alcohol type of canned fuel or solidified alcohol.
20-267M..... 12.50



TENT REPAIR KIT

Everything you need for quick emergency repairs to your tent.
20-130M..... 6.50



WATER BASED SEAM SEAL

The easy to use applicator applies waterproofing for sewn seams on nylon and other synthetic outdoor fabrics. It's colorless, flexible and washable.
20-118M.....2 fl. oz.7.95



CAMP HEAT

For cooking or heating at camp, home or in emergencies. Approximately 4 hours burn time per tin.
20-268M.....2 tins/6.4 oz.ea. 10.25



TENT POLE REPAIR KIT

Fix broken tent poles quickly. 45" (114 cm) shock cord. 30" (76 cm) wire. Six washers. Two ferrules (8.5 mm, 9.5 mm).
20-187M..... 3.95



PARACORD - 50 FT

Great for survival bracelets, shelter building, gear repair and more, this cord is a "must have product" for campers, hunters, survivalists and backpackers. The Type III, commercial grade, 550 cord features seven individual inner core strands. Adding strength, these strands can also be used separately for any number of things such as sewing thread or as a fishing line. Will not rot or mildew. Overall length: 50'. Safe working load: 100 lbs.
20-2005M.....Olive.....6.95
20-2015M.....Orange.....6.95



9" TENT PEGS

Bright, easily seen and durable polypropylene rugged design with large no-slip hook.
20-616M..... 5.50



FIRE STICKS (PK. OF 12)

A fast, easy way to start barbecues, campfires and fireplaces. Sticks are non-toxic, leave no odor, and burn completely. They even light after being submerged in water.

20-165M.....4.95



MATCHES

Approximately 45 wooden matches to a pocket size box. Ideal for Hunters, Fishermen, Campers or Outdoor Workers. Safety Matches cannot light accidentally. Must be struck on waterproof striker surface on box.

20-108M.....Pk. of 4.....3.25



MAGNESIUM FIRE STARTER

A must for every field trip. The fire starter uses magnesium, a flame source of 5400°F (2982°C) One fire starter should provide sufficient shavings to start hundreds of fires.

20-380M.....6.95



FIRE DISC

Made of cedar and highly refined wax, they are designed to light easily and to burn hot. Since most meals take less than 30 minutes to cook, they are also a perfect solution as an emergency source of heat for cooking. Can be stored indefinitely.

20-2000M.....2.50



GROMMET KIT

Brass plated for canvas, plastic, leather.

Kit consists of: 20, 3/8" grommets, cutting tool, insert punch and setting die.

20-111M.....6.95



FIRE LIGHTERS

These handy, odorless fire lighters make lighting a fire quick, easy and clean. No matches, paper, or kindling are required. Burn time: 5 minutes

20-1998M.....5.95



FLINT STRIKER

Lasts for thousands of strikes! Scraping the provided striker down the rod emits sparks to light combustibles. Fireproof in solid form, the tool works just as well when wet.

20-2035M.....5.95



POCKET CHAINSAW

Stainless steel chain-link blade (26 teeth) . Easily cuts through wood. Saw teeth cut in both directions. Nylon pouch with belt loop. Size: 20" long chain. Polyester wrist straps.

20-2069M.....14.95



SNAP FASTENER

Everything you need to install snap fasteners. Uses: Boats, tents, trailers. Consists of: 8 sets of nickel-plated screw-in, stud to canvas fasteners, flaring tool and base.

20-113M.....4.95



STORM MATCHES

Windproof and waterproof matches. The case contains 20 Storm Matches. Matches burn for up to 10 seconds, even when wet. Strike pad on the outer case, and the second one under the watertight bottom lid. Watertight container with rubber O-ring.

20-2085M.....5 cm.....8.95

20-2086M.....10 cm.....10.95



EMERGENCY STOVE

Light, strong and compact. Requires no liquids, no priming, no wick and no pressure – the ideal emergency stove. 24 Fuel Tablets included.

20-152M.....6.95



FUEL TABLETS

For use with Coghlan's Emergency Stove to the left. A safe, clean burning fuel, easy to ignite, smokeless, odorless and non-toxic. 24 tablets per box

20-153M.....3.25



CORN POPPER

Classic design makes great tasting popcorn every time. Great for roasting chestnuts too! Use over a campfire or fireplace. The sliding lid is easy to open and the space-saving handle stores inside the corn popper when not in use. Wooden grip keeps handle cool and comfortable. Clean up is easy with the non-stick surface.
20-580M 30.95



G.I. CAN OPENER

A handy nickel-plated pocket can opener.
20-155M 2.50



FOLDING SCISSORS

Stainless steel blades. Chrome plated die cast handles.
20-106M 3.50



SKEWER-STICKS (4PCS.)

Chrome plated skewers with flat sides to keep food from twisting.
20-582M 3.95



SOLO TABLEWARE

Made of up to 50% wheat straw bio infill to reduce use of plastic. Easy to transport with mesh bag. 1 large plate, 1 bowl, cutlery set, and 1 tumbler cup.
20-2082M 19.50



CAMPERS KNIFE

This multi-tool features a knife blade, fork, spoon and can punch. High impact steel handles with inset rubber grips detach to give a two-piece utensil set. The fork pivots to lock the two halves together when not in use for easy storage.
22-150M 6.95



CHOW KIT (KNIFE, FORK & SPOON SET)

Three piece stainless steel knife, fork and spoon set clip together for easy carrying and storage. Comes with a reusable pouch.
20-585M 3.95



DRINKING WATER TABLETS

One tablet will disinfect approximately one quart of water. Contains: 50 tablets in each bottle.
20-625M 10.95



WATERPROOF POUCH

Strong vinyl pouch with hook and loop Velcro® closure. Size: 5" x 7". Ideal for storing your cell phone, gps, camera, or other items you want to keep dry during activities where you will or may get wet.
20-634M 3.50



COUGLANS "CONTAIN-ALLS" KIT

Food safe plastic containers with interchangeable caps for every pourable liquid or solid such as instant coffee, sugar, cooking oil, lotions, pills, ointments, etc.
20-320M 8.50



COGHLANS "LIGHTSTICKS" 4 PER PK

Assorted colors, Yellow, Green, Blue, Red

20-322M.....7.95



STRETCH STRAPS

Sturdy stretch cord with plastic coated hooks on each end. Will not loosen in travel.

20-626P.....20" (Pk. of 2) 3.95/pk.
 20-627P.....33" 2.95/ea.
 20-628P.....40" 3.25/ea.



Actual Size



LED MICRO LANTERN

The Micro Lantern uses a specially designed conical reflector and a bright Nichia™ 5mm LED to illuminate everything within a 6.5' (2m) diameter. It's the perfect tent or walking lantern and it fits in the palm of your hand. At only 2" (5cm) high, the Micro Lantern "Shines Bright and Packs Light". Water resistant with a positive feel rubber ON/OFF button and flashing mode for emergencies. Attaches to your pack or jacket for the ultimate in portable light.

20-594M 12.95

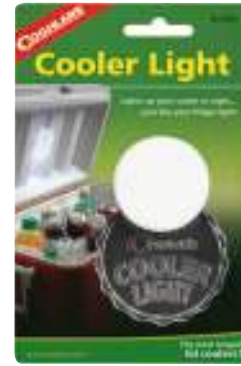

COOLER LIGHT

Lights up your cooler at night...just like your fridge light! The light is designed to turn on when the lid is raised and to turn off when the cooler lid is closed. The Cooler Light will shut off automatically after 20 seconds regardless if the lid is shut completely. Great for coolers, tackleboxes, toolboxes.

20-623M 12.95



NET TOSS SET

Coghlan's Net Toss Set is a portable way to play this classic beanbag toss game. Using collapsible target nets this game can be set up anywhere. Includes 2 nets, 2 poles, 4 pole caps, 6 beanbags (3 red, 3 yellow), 4 anchor pegs, storage pouch. Each net is 10" wide.

Product Dimensions: 10.5" x 11.5" x 1" (266 mm x 292 mm x 25 mm).
 20-2063M 21.50



COLD WEATHER STRAP

Made in Canada by Snappi Hooker. Operational to -40C. Injection molded EPDM meaning no imperfections. 2-1/2 times safe stretch, non-cracking. Meets DOT safe working load limit (no others do). Made to ISO9001/AS9100 quality certification.

46-2101M.....9" 3.95/ea.
 46-2102M.....15" 5.50/ea.
 46-2103M.....20" 6.95/ea.
 46-2104M.....30" 8.50/ea.



LARGE BINER CARRY HANDLE

The Large Biner has dozens of uses - carry multiple grocery bags, cables or cords, this comfortable grip will do it all! Made from durable aircraft aluminum and features an extra wide 3" gate. It's a great tool for camping or around the house. Size: 3-1/2" x 7-3/4"

20-309M 5.50



KIDS BINOCULARS

Coghlan's Binoculars For Kids are made from sturdy and safe plastic with large lens that provide a 4 x 30 magnification. Features an adjustable focus dial and break-away child-safe lanyard.

20-650M 9.95





S'MORES GRILL

Everyone's favorite campfire treat. This compact grill is all you need to make perfect S'mores over your campfire or backyard grill. Put the S'mores into one of the three cooking cavities and hold above the flames until the graham cracker is lightly toasted. Features a sliding lock ring to keep the grill closed while cooking.

20-704M 10.95



PACK GRILL

Folds flat for easy storage or packing. Made from a chrome plated steel construction.

Grill surface: 12 1/2" x 6-1/2"
20-708M 8.50



EXTENDIBLE FIRE POKER

This sturdy chrome plated fire poker is perfect for camping or the backyard fire pit and features a stay-cool wooden handle. Extendible shaft provides safe working distance of 17" - 30". Retractable shaft for easy storage. Includes leather hanging loop. Shaft locks into place.

20-2021M 12.95



BUG JACKET

Made with ultra-fine no-see-um polyester mesh, this jacket provides the ultimate protection against mosquitoes and other flying insects! Flame retardant and lightweight, it also features elasticized drawstrings at the waist and cuffs. Zippered at the neck for easy access to the face.

20-2050MSm 18.95
20-2051MMed..... 18.95
20-2052MLg 19.95
20-2053MXL 21.95



TELESCOPIC FLY SWATTER

This compact fly swatter is perfectly suited for eliminating pesky flies, mosquitoes, and other insects. It has a reach of over 18" when extended, and features a comfortable wooden handle and leather strap for hanging when not in use.

20-170M 4.95



COMPACT MOSQUITO HEAD NET

Made of polyester mesh, this mosquito head net fits into the included stuff sack for storage and transportation. It's easy to see through and keeps mosquitoes and other insects out. Designed with a string and toggle to tighten as desired - not recommended for children. Assorted Colours.

20-326M 5.50



PARACHUTE HAMMOCK

Compact, it fits inside the integrated stuff sack which doubles as a pocket for small items. The additional side pocket is ideal for storing books, tablets, and water bottles. It's available in blue, or green. 70D nylon construction - triple stitched seams for durability.

20-2042MSingle (Up to 300 lbs) 67.95
20-2062MDouble (Up to 400 lbs) 82.95

KIDS



YOUTH BUG JACKET

Made from ultra-fine no-see-um polyester mesh this youth jacket provides protection against mosquitoes and other flying insects! Flame retardant and lightweight, it also features elasticized drawstrings at the waist and cuffs. Zippered at the neck for easy access to the face. Recommended for ages 8 and up

20-2054M 17.95



CAMP KNIFE - 5 FUNCTION

Tools included are: large knife blade, can opener, bottle opener/screwdriver, corkscrew, hole punch, toothpick and tweezers.
20-2066M.....4.95



CAMP KNIFE - 7 FUNCTION

Tools included are: large knife, blade, scissors, bottle opener/ screwdriver, corkscrew, can opener, Phillips screwdriver, toothpick, mini tweezers, and file.
20-2067M.....6.95



CAMP KNIFE - 11 FUNCTION

Tools included are: large knifeblade, can opener, scissors, saw, file, fish scaler/hook disgorging, awl, hole punch, corkscrew, Phillips screwdriver, bottle opener/screw-driver, toothpick and tweezers.
20-2068M.....7.95



SOLAR CAMP SHOWER BAG

Lightweight, non-toxic PVC Camp Shower stores enough water for 3 - 4 showers. Compact and easy to use, includes cord for hanging.
20-587M.....16.95



SILICONE TRAVEL BOTTLE SET

These soft, silicone tubes are ideal for the outdoors and anywhere the next adventure takes you. The integrated hole allows them to be securely attached to a bag or backpack with a carabiner (not included) in seconds. Food-safe (FDA), 100% BPA-free and phthalate-free, they are rugged enough for a backpack and soft enough to allow all of the contents to be squeezed out. Airplane carry-on approved sizing ensures worry-free check-ins.
20-2029M.....20.50



TOILET SEAT COVERS

Biodegradable sanitary disposable Seat Cover.
20-610M.....Pk. of 10 1.95



TOOTHBRUSH COVERS - 2 PACK

Coghlan's Silicone Toothbrush covers keep your toothbrush from getting dirty or contaminated between brushings. The food-grade silicone is flexible and easily slips over most standard and electric toothbrush heads and can be easily sanitized in a dishwasher or boiling water. Each package contains 1 white and 1 blue cover.
20-2041M.....1.95



EMERGENCY PONCHO

Lightweight, reusable hooded polyethylene poncho. One size fits all. Size: 50" x 80" (127 x 203 cm)
20-619M 1.50



KIDS

EMERGENCY PONCHO FOR KIDS

Lightweight and reusable poncho with attached hood. Fits kids ages 6 and up.
20-620M 1.50



RAZOR COVER

Protects razor blades when traveling. Made of food-grade silicone. Dishwasher safe. Fits most disposable and cartridge razors. 2 per pack (blue and white).
20-2073M.....1.95



CAMP CARABINER

The Camp Carabiner is a versatile tool for hanging gear on a line without knots. It features a twist-and-clip design for easy attachment to 550 paracord or 4 mm rope, a 1/4-20 attachment point for compatible lighting and electronic devices, and swivels 360° for easy access to gear. It can hold up to 25 lbs. and is perfect for camping, hiking, and hunting.

20-2100M.....14.95



CARABINER LIGHT KIT

The Carabiner Light Kit is a rechargeable LED light that can be attached to keys, backpacks, or used as a mini lantern, flashlight, or signal. With 4 light modes and runtimes of 1.5 to 4 hours, it recharges in 40 minutes and is IPX4 water-resistant. It also includes a webbing adapter and a paracord adapter to convert it to a Camp Carabiner for hanging electronics and gear at camp.

20-2101M.....38.95



TAUT LINE KIT

The Taut Line Kit is a versatile outdoor tool that includes a 50 ft heavy-duty, reflective paracord and line tensioners for setting up a tight camp line to hang gear and clothes. The paracord has 7 inner strands that can be used as fishing line or thread.

20-2102M.....26.50



TENACIOUS TAPE GORE-TEX FABRIC PATCHES

Quickly fix ripped GORE-TEX gear with Tenacious Tape GORE-TEX Fabric Patches. This kit includes two adhesive-backed fabric patches that can be cut to size for any hole, rip or tear on waterproof-breathable jackets, ski pants and gloves. Apply with pressure or heat for maximum hold. Durable and washable, these patches provide long-lasting repairs for all your GORE-TEX gear.

20-2103M.....9.50



TENACIOUS TAPE FLEX PATCHES

Tenacious Tape Flex Patches are ideal for heavy-duty repairs that need flexibility. Made of strong TPU tape, it won't puncture or peel and is resistant to abrasions. Use it to patch holes on vinyl furniture and inflatables. The clear, waterproof tape forms an impermeable seal that flexes with the material.

20-2104M.....10.50



TENACIOUS TAPE REPAIR TAPE

Quick fix for tears and rips - Tenacious Tape is a strong and weatherproof tape that can fix tents, ski pants, and puffy coats. Available in clear and various colors, it's backed by an ultra-aggressive adhesive that won't peel off on technical fabrics. Instantly repair gear and make it machine washable after 24 hours.

20-2105MBlack.....7.95

20-2106M.....Clear.....7.95



TENACIOUS TAPE REFLECTIVE

Keep visible and safe with Tenacious Tape Reflective. This fabric tape uses glass bead technology to reflect light better than colored or fluorescent tape, making it perfect for use on jackets, backpacks, shoes, bike gear, helmets, and pet accessories. The ultra-aggressive adhesive sticks to almost any surface without peeling, and the tape is washable.

20-2107M.....9.95



ZIPPER REPAIR KIT

Compatible – Fix zippers like a pro with the most common zipper sizes with sewing tools included in one kit

20-2108M.....15.95



SEWING KIT

Make durable repairs on the go with this complete sewing kit to repair outdoor gear and fabrics

20-2109M.....11.95



ZIPPER STICK

High performance zipper lubricant for water tight and air tight zippers. Protects against rust, corrosion, chlorine and salt in all temperatures. Provides UV protection for nylon and plastic zippers. Non-toxic and biodegradable. Repels dirt, sand and organic residue. Contains no silicone or paraffin

20-2110M.....8.50



AQUASEAL FD REPAIR ADHESIVE

Aquaseal FD is a clear, waterproof adhesive that quickly repairs outdoor gear. It offers excellent abrasion resistance and cures to a flexible rubber glue. Ideal for fixing gear in constant motion, it can also be used as a seam sealer. Don't let rips, tears, and holes stop you, fix it with Aquaseal FD.

20-2130M.....12.95



AQUASEAL FD REPAIR KIT

This small but mighty package contains everything you need to permanently repair rubber, neoprene or waterproof-breathable waders, including Gear Aid's powerful Aquaseal and Tenacious patches. At 3.5" x 1", the Aquaseal Wader Repair Kit fits in your fishing vest and is ideal for keeping that cold, wet feeling out of your favorite waders.

20-2131M.....12.95



NI GLO GEAR MARKER

A rechargeable, glow in the dark keychain and marker for keys and outdoor gear. It charges by sunlight or artificial light and glows brightly at first, then fades to a constant glow that can be seen all night. It is IPX8 waterproof, dust-proof, and weatherproof, can be attached to various gear and is small and lightweight.

20-2111M.....Green7.95
 20-2112M.....Orange7.95
 20-2113M.....Yellow7.95



AQUASEAL NEO CONTACT CEMENT

Repair torn or ripped neoprene wetsuits and waders permanently within 30 minutes using this contact cement, which cures to a black, flexible rubber

20-2132M.....11.50



AQUASEAL SR SHOE REPAIR ADHESIVE

Fix footwear permanently at home or in the field with Aquaseal SR. Formerly known as Freesole, this shoe repair adhesive is waterproof and dries as a clear, flexible glue that lasts for years.

20-2133M.....11.50



BURI UTILITY KNIFE

The Buri is a compact utility knife with a titanium-coated 3" drop point blade, suitable for cutting line, slicing food, breaking glass, and opening bottles. It features a full tang blade made of 5Cr15 stainless steel and a quick-release sheath with multiple attachment options. The knife also has a built-in glass breaker and is MOLLE compatible for mounting on packs or camp gear.

22-2000M.....Orange34.95
 22-2001M.....Black.....34.95



AKUA RIVER KNIFE

The Akua River Knife is a versatile tool for freshwater adventures, with a stainless steel blade featuring a blunt tip, serrated edge, and line cutter. It attaches to PFDs, deck bags, or belts, and has a quick release sheath for immediate access. It also includes a bottle opener and a glass breaker. Suitable for cutting fish, lures and ropes.

22-2002M.....Green34.95
 22-2003M.....Black.....34.95

SHOP 24/7 FROM THE COMFORT OF YOUR OWN HOME

- Up to date Pricing
- New Products
- Stock Status
- Additional product info
- And more



www.mercersmarine.com

Great for Snowmobilers



TARPAULINS

Fiberglass reinforced polyethylene. Rust resistant grommets every 3 or 4 feet. 30 micron coating - both sides. Shrink and rot proof. Extra Strong.

Ord. No.	Size	Price
40-007R	6' x 8'	5.75
40-008R	8' x 10'	9.50
40-035R	9' x 12'	12.95
40-036R	10' x 15'	17.95
40-010R	12' x 18'	25.95
40-037R	15' x 20'	35.95
40-011R	18' x 24'	51.95
40-012R	20' x 30'	71.95
40-048R	24' x 40'	114.95
40-013R	30' x 50'	179.95
40-014R	40' x 60'	289.95

CAMOUFLAGE TARPAULINS

Heavy duty woven ripstop polyethylene. Grommets spaced along each side. Turned edge strung with rope.

Ord. No.	Size	Price
40-147M	8' x 10'	25.95
40-148M	10' x 12'	38.25



DOUBLE ACTION PUMP

Ideal for larger size inflatables. Delivers a continuous stream of air in both up and down strokes. Light weight, non-corrosive plastic. Large handle. Non kink hose with multi adapters.

32-115R	31.95
---------	-------



FOLDING SHOVEL

Steel blade • Nylon handle • Ballistic nylon case with velcro closure • Spring load assembly for safe operation. Great tool aboard every snowmobile!

20-025M	25.25
---------	-------



SNOW BRUSH & ICE SCRAPER

Designed to remove snow from cars & trucks. Large 15" x 5-1/2" foam pad has 3 levels to minimize any scratching. head locks into 7 positions to give required angle. Handle locks from 30" to 49" with a total of 8 positions.

70-105K	15.95
---------	-------



TELESCOPIC ICE SCRAPER WITH BRUSH

6" scraper. Extendable handle 30" to 45". Adjustable angled brush and squeegee.

70-114K	15.95
---------	-------



SHOVELS (STEEL)

Long Handle Type (45")

20-157M	Round Top (45" Handle)	37.50
---------	------------------------	-------

20-158M	Square Top (45" Handle)	37.95
---------	-------------------------	-------

D-Handle Type (28")

20-197M	Round Top (28" Handle)	28.50
---------	------------------------	-------

20-198M	Square Top (28" Handle)	28.50
---------	-------------------------	-------

Great for sporting events.



PUMP ECO AIR HORNS

Pump style air horn. Water resistant. No disposable canisters. Great for sporting events.

Small Model

(Air chamber Length 4 1/4" x 1 1/2")

28-1146R	8.95
----------	------

Large Model

(Air chamber Length 5 1/4" x 2")

28-1147R	11.50
----------	-------



GKS SNOWSHOES

Snowshoes with pivot. Aluminum frame. Harness with ratchet adjustment Comes with storage/carry bag.
 20-504M(18") Up to 100 lb 82.95 /Pr.
 20-505M(22") 100-175 lb 87.95 /Pr.
 20-506M(27") 175-225 lb 101.95 /Pr.
 20-507M(30") 225-250 lb 108.95 /Pr.
 20-508M(38") 250 plus lb 124.95 /Pr.
 20-509MPoles 39.95 /Pr.



GKS SNOWSHOE POLE

The Ganka GKS Snowshoe Poles is 0.8mm aluminum, telescopic, and sold as a pair.
 20-509MPoles 39.95 /Pr.



SAFETY ICE CLAWS

A must for safety conscious snowmobilers. Comes with adjustable string to be worn around neck. Provides grip on ice when trying to get out of the water.
 20-421K.....16.95



KODRA SNOWSHOE HARNESS

1000 denier fabric will not absorb water. Nylon webbing. Quick release heel strap. Attaches easily with ladderlock buckles and webbing.
 20-137M19.25 /Pr.



GENUINE LEATHER SNOWSHOE HARNESS

A superior quality, heavy duty thick leather harness. Made in Newfoundland. Extra strong rivets and fastening system. Fits most snowshoes.
 20-211K 27.95 /Pr.



www.mercersmarine.com





- Always Open
- Sale & Feature items
- View Catalogue



- Thousands of products
- Updated Regularly
- Up to date Pricing



- Mobile Friendly
- Shop from anywhere at anytime

Also find us on   



NORMARK 6" NORDIC ICE AUGER

Telescopes for easy transport. Comfort grip handles. Tough powder coated enamel finish. Rugged Design. Precision stainless cutters. Includes durable head cover. Blades are interchangeable with Swede Bore.
 20-283K.....6" Auger 99.95
 20-284K.....Repl. Blades21.50
 20-285K.....Repl. Blade Covers.....10.95
 20-277K.....Repl. Cutter bolts.....10.95 pk/4
 20-894K.....Repl. Wing Bolt.....8.95



BRACE & BIT STYLE (SWEDE BORE)

20-221K.....5" Auger 116.95
 20-222K.....6" Auger 132.50
 20-223K.....5" Repl. Blades33.95
 20-224K.....6" Repl. Blades37.95
 20-892K.....5" Repl. Blade Covers.....15.95
 20-893K.....6" Repl. Blade Covers.....15.95
 20-277K.....Repl. Cutter bolts.....10.95 pk/4
 20-894K.....Repl. Wing Bolt.....8.95



FIN-BORE "TELESCOPIC HANDLE"

20-279K.....4 1/2" Auger 146.95
 20-280K.....6" Auger 159.95
 20-272K.....4 1/2" Repl. Blades41.95
 20-273K.....6" Repl. Blades46.95
 20-890K.....4 1/2" Repl. Blade Covers.....15.95
 20-891K.....6" Repl. Blade Covers.....15.95
 20-277K.....Repl. Cutter bolts.....10.95 pk/4
 20-894K.....Repl. Wing Bolt.....8.95



See "RAZOR" Drill Adaptor Below

"RAZOR" 4 1/2" FIN BORE FOLDING AUGER

Cut through the ice quickly and easily with the Emery® Razor folding Ice Auger. The stainless steel auger features a powder coated drill bit, comfortable grip handle, Lightweight construction and attached folding handle make it easy to transport across the ice.
 - Folding shaft for easy storage and transport
 - powder coated for protection against rust
 - cuts 4 1/2" holes
 20-310M.....4 1/2" Auger 122.95
 20-311M.....Repl. Blades19.95
 20-312M.....Repl. Blade Covers.....9.95
 20-314M.....Razor Ice Drill Adaptor.....10.95



AUGERSHARP SHARPENER

The AugerSharp Ice Auger Sharpener is the Ice Fisherman's dream. If you ice fish, you know what work it is when your auger blades are dull. Now you can spend more time fishing and less time drilling holes in the ice.
 22-412R.....14.95



ELECTRIC ICE DRILL ADAPTER

Fits existing models of Fin-Bore, Swede Bore, Nordic, & Mora brand ice drills. Stainless steel construction. Fits 4", 6" and 8" Augers.
 20-281M 16.95



COMPAC JIGGING ROD

Suitable for year round vertical fishing. EVA handle.
 20-425M16" Long 13.95



RAPALA 4" FOLDING ICE FISHING SCOOP

Overall length 13-1/2". Folded is 10". No more cold hands scooping out the hole.
 20-278M 5.95



RAPALA TEHO-3 ICE FISHING ROD

Double rod tip for feeling light strikes and fighting heavier fish. Removable tip for storage.
 20-422M 12.95



PREMIUM ICE LINE

The Sureline Arctic Blue Premium Ice Line is designed for high performance in freezing conditions. The 110 yard ice line has superior knot control and great strength despite its micro size.
 20-426M.....10 lb test. 5.29



GARANT AXES

Great line of axes. Large slim cutting edge. Hardened steel blade. Fiberglass handle with soft, non slip grip for maximum shock absorption.

- 20-565M16" Handle (1.5lb)..... 25.95
- 20-566M28" Handle (2.25lb)..... 41.95
- 20-567M34" Handle (3.5lb)58.95



BEAVER AXE

Traditional Newfoundland favorite for years.

- 20-896M1 1/2 lb x 15" Handle21.95
- 20-020M1 3/4 lb x 26" Handle57.50
- 20-019M2 1/2 lb x 27" Handle60.95



Made In Germany

OXHEAD AXE

"OXHEAD" Brand (German)

- 20-097K2 1/2 lb x 28" Handle199.95



Hultafors

HULTAFORS AXE WITH CASE

A small axe for outdoor use in forests and open land. Made from blasted and clear-lacquered ironwork, it is also suitable for work in the garden. The shaft is curved and made from hickory. Leather axe sheath is included. The steel is struck several times, increasing its density and thereby the durability of the axe. Has a clear tempered zone within which the axe can be sharpened whilst not detracting from the strength of the edge. The shaft is made from hickory and treated with linseed oil.

- 20-569K16" 131.95
- 20-561K20" 199.95
- 20-572K26" 189.95
- 20-564K26" (NO SHEATH) 104.95



HICKORY AXE HANDLES

- 20-547M15" Handle 11.95
- 20-548M24" Handle33.95
- 20-549M28" Handle33.95
- 20-550M36" Handle36.95



32" HOOKARON (HICKORY)

- 20-038H 65.95



8" AXE FILE

8" File with handle 11 1/2" overall. 1 side single, 1 side double cut, 1 edge cut, 1 edge uncut. Rectangle shape.

- 22-046R 8.95



PACK AXE

Non-slip rubber grip designed for comfort. Stores inside the black nylon sheath for protection.

- Weight: 14.5 oz. Length: 10"
- 20-611M 29.50



Made In Germany

OX-HEAD DRAWING KNIFE

Made in Germany. Forged steel with 4-1/2" wooden handles. 10" cutting edge.

- 22-008M 104.95



Hultafors

HULTAFORS SHARPENING WATERSTONE

Made in Sweden. Leather case with usage instructions. Offers 2 grits: 180 & 600. To be used with water for best results. 3" diameter x 1" thick.

- 22-180M 75.95



**Shop or Browse
Online 24/7
at
mercersmarine.com**





POLY RUNNERS

Poly Runners are used frequently on bobsleds and komotiks. Also used on gunnels and keels of boats. Supplied in the following widths. Please call or check our website for current pricing. (www.mercersmarine.com)

40-121P1/4" x 2" x 10' P.O.R.	40-111P3/8" x 2" x 10' P.O.R.	40-116P1/2" x 2" x 10' P.O.R.
40-122P1/4" x 2 1/2" x 10' P.O.R.	40-112P3/8" x 2 1/2" x 10' P.O.R.	40-117P1/2" x 2 1/2" x 10' P.O.R.
40-123P1/4" x 3" x 10' P.O.R.	40-113P3/8" x 3" x 10' P.O.R.	40-118P1/2" x 3" x 10' P.O.R.
40-124P1/4" x 4" x 10' P.O.R.	40-114P3/8" x 4" x 10' P.O.R.	40-119P1/2" x 4" x 10' P.O.R.
40-125P1/4" x 6" x 10' P.O.R.	40-115P3/8" x 6" x 10' P.O.R.	40-120P1/2" x 6" x 10' P.O.R.
40-126P1/4" x 8" x 10' P.O.R.	40-128P3/8" x 8" x 10' P.O.R.	40-130P1/2" x 8" x 10' P.O.R.
40-127P1/4" x 48" x 10' P.O.R.	40-129P3/8" x 48" x 10' P.O.R.	40-131P1/2" x 48" x 10' P.O.R.
40-132P3/8" x 2" x 12' P.O.R.	40-139P1/2" x 2" x 12' P.O.R.	
40-133P3/8" x 2 1/2" x 12' P.O.R.	40-140P1/2" x 2 1/2" x 12' P.O.R.	
40-134P3/8" x 3" x 12' P.O.R.	40-141P1/2" x 3" x 12' P.O.R.	
40-135P3/8" x 4" x 12' P.O.R.	40-142P1/2" x 4" x 12' P.O.R.	
40-136P3/8" x 6" x 12' P.O.R.	40-143P1/2" x 6" x 12' P.O.R.	
40-137P3/8" x 8" x 12' P.O.R.	40-144P1/2" x 8" x 12' P.O.R.	
40-138P3/8" x 48" x 12' P.O.R.	40-145P1/2" x 48" x 12' P.O.R.	



LEATHER AXE BRACKET

Heavy leather axe case. Can be riveted to snowmobile or quad. Comes with support strap for handle. Will not crack in cold weather. Bottom corners open for drainage. Fits most 1 3/4" to 2 1/2" lb Axes. **GREAT PRODUCT!**

20-063K..... 32.95



FIRE AXE BRACKET

Chrome plated brass blade bracket, stainless steel handle holder.

50-012R..... 29.90



AXE MATE

For safe and convenient storage, secure to your snowmobile, ATV, RV, boat, truck, or in your barn, workshop, garage, etc. Completely portable for in the woods or camping.

20-053M..... 17.50



QUICK PIN-SQUARE SPRING TYPE

Zinc dichromate finish. 3/8" Dia. x 2 1/4" usable length.

20-405T 1.15



QUICK PIN-CURVE SPRING TYPE

Zinc dichromate finish.

20-541T.....1/4" x 1 5/8" 0.75
 20-542T.....5/16" x 1 3/4"0.90
 20-543T.....3/8" x 1 3/4"0.90



HAIR PINS

Ideal for use with snowmobile sleds.

20-300T.....3/32" Dia. x 2 1/4" OL 0.22
 20-301T.....1/8" Dia. x 2 1/2" OL0.25
 20-302T.....5/32" Dia. x 3 1/8" OL0.40
 20-303T.....3/16" Dia. x 3 3/4" OL0.65
 20-304T.....1/4" Dia. x 4 1/4" OL0.75



316 Stainless Steel

"STAINLESS STEEL HAIR PIN

Eliminate problems of rust and corrosion. #316 Stainless Steel.

46-1309R2mm x 50mm (Approx. 1/16" x 2").....0.32/ea.
 46-1310R3mm x 60mm (Approx. 1/8" x 2 3/8").....0.64/ea.
 46-1311R.....4mm x 60mm (Approx. 5/32" x 2 3/8").....0.99/ea.
 46-1312R.....5mm x 85mm (Approx. 3/16" x 3 3/8").....1.79/ea.
 46-1313R.....6mm x 105mm (Approx. 1/4" x 4 1/8").....2.89/ea.



LINCH PINS

Zinc dichromate finish.

20-400T.....3/16" x 1 1/4" 0.51
 20-401T.....1/4" x 1 1/2"0.53
 20-402T.....5/16" x 1 3/8"0.76
 20-403T.....3/8" x 1 3/8"0.78
 20-404T.....7/16" x 1 1/2"0.95





RATCHET PULLER

Steel construction. Forged snap hooks. Approximately 10ft of cable on drum.

- 40-155R2 Ton Rated.....39.95
- 40-156R4 Ton Rated.....69.95



LOAD BINDERS

- 40-152R5/16" X 3/8" WWL 5400lbs.....39.95
- 40-153R3/8" X 1/2" WWL 9200lbs.....49.95
- 40-154R1/2" X 5/8" WWL 13,000lbs.....69.95



12" INDUSTRIAL HACKSAW

Heavy duty steel frame. Aluminum + ABS + TPR handle. Strong and Comfortable. Adjustable tension. Quick-release blade changing mechanism. Includes 1 saw blade.

- 20-296M.....Hacksaw.....22.95
- 20-297MReplacement 12" Blade.....2.50



G CLAMP

Body malleable cast iron. T-shaped thread.

- 48-110M3"12.25
- 48-111M4"13.25
- 48-112M5"16.25
- 48-113M6"19.25
- 48-114M8"31.25



MEASURING TAPE

With metric and inch. With 3 stop button function. With rubber cover.

- 70-998R.....30'10.95



RATCHET PULLER

Puller 1 Ton Double Gear. 6 metres x 10mm Poly Rope.

- 46-2002M1 Ton Rated.....106.95



ROPE HOIST

General purpose Hoist.

Cadmium-plated housing with welded rings and double grip safety hooks. Supplied with 65 ft of polypropylene rope. Lifting capacity of 1000 lbs.

- 46-1075P28.50



MEASURING TAPE

Power return measuring tape — ISO certified. Triple riveted end hook. Easy to find florescent orange ABS case. 16" markings indicated. Includes wrist lanyard and belt clip.

- 70-898R25'8.50



MEASURING TAPE

3:1 Gear ratio for fast rewind. With metric and inch. Pure material retracting gear. With all rubber cover. Integrated handle good for using and convenient storing.

- 70-1000R.....100 feet22.95



NYLON TOW STRAP

2" X 25' Nylon. 8500 lbs Strength. Ideal for emergency pulling. Strong nylon webbing straps with chafe protection at ends for longer life. Stretches to absorb shock. Two drop forged hooks and safety latch included. Weight 6 lbs.

- 46-2000R.....30.95



TROUBLE LIGHT

16/3 AWG, 1 OUTLET SJTW. Bulb Not Included.

- 28-751M25'32.95



INDOOR/OUTDOOR EXTENSION CORDS

cUL approved. SJTW wire type, 13 amp, 16/3 wire size.

- 28-403P10'10.95
- 28-404P16'14.95
- 28-405P32'30.95
- 28-406P49'45.50
- 28-407P98'87.95



Housewares





CUISINART ICE CREAM MAKER

Cool off with a rich homemade ice cream sundae or a fruity sorbet – ready in 25 minutes or less. The Cuisinart® Pure Indulgence™ Frozen Yogurt-Ice Cream & Sorbet Maker delivers 2 quarts (1.9 L) of fast, fabulous, frozen desserts, perfect for a family dinner or a friendly party – each one guarantees a sweet ending!
70-2309K.....182.95



FOOD SLICER

Premium coated steel and die-cast aluminum housing. 7.5" stainless steel cutting blade for perfect performance. Slice control knob adjusts from 1/32" to 1/2" to slice bread, roasts, firm cheeses and more. Heavy duty 130 Watt motor. Suction feet for stable, non slip operation.
70-2299K.....180.95



PROFESSIONAL MEAT GRINDER

Choose your favorite meat or fowl and fill the large die cast hopper. Select one of 3 grinding discs or either of 2 sausage attachments and the heavy duty 150 watt motor quickly and consistently grinds to order. A single on/off switch and convenient reverse function make operation easy. Finished in brushed stainless steel.
70-2303K.....180.95



MEAT GRINDER

Heavy metal construction. #8 clamps on side of bench or table. #12 bolts on top of bench or table. Sausage attachments available.
70-051K#863.95
Replacement Blade
70-160K.....For #89.95
Plastic Sausage Nozzle
70-2205KFor #811.25



VICTORINOX PARING KNIFE

22-235M.....Straight Blade 3-1/4"10.29



VICTORINOX PARING KNIFE

Pointed tip. Ergonomic handle. Dishwasher safe.
22-236MOrange Handle9.49
22-237MYellow Handle9.49



RECIPE BOOKS

Coil bound books for collecting your favorite recipes. Blank pages are 6" x 8 1/2". These books do not have recipes.
20-464MRecipes from my Kitchen.....17.50
20-465MRecipes from my Cabin17.50
20-467MRecipes from my RV17.50



NO STREAK MICROFIBER CLOTH

USE ONLY WATER! For use with just about everything. Cleans windows, glass, acrylic, vinyl, tv's, computers, windshields, mirrors, chrome, plastics, stainless steel, counter tops, oven faces and more. Throw away your window cleaners. Removes dust, dirt, finger prints, soap scum, tar, grease, bugs and more. **AIR DRY ONLY. NO FABRIC SOFTENER.** Machine wash with bleach or detergent.
70-039R.....2.99



**Shop or Browse
Online 24/7
at
mercersmarine.com**

Lodge Cast Iron

As the only full line of American-made cast iron cookware, Lodge boasts quality that has been unmatched for over a century. Even heating, a natural easy-release finish, versatility and durability are the hallmarks of our great cookware. We don't just make cast iron; we make heirlooms that bring people together for generations.



Kitchenware



3.2 QUART CAST IRON COVERED DEEP SKILLET

With an extra inch of depth added to the traditional 10.25 inch skillet, this versatile pan by Lodge can do it all from deep frying to bread baking, and includes an iron cover for even more possibilities

70-1901K.....3.2 qt115.50



FAJITA SET

Add sizzlin' color to your fajitas with the Lodge Fajita Set. Includes oval fajita griddle, red stained 1/2 inch touted wooden underliner and chili pepper hot handle mitt. Griddle maintains food's warmth. Can be used on all stovetops, ovens and grills.

70-1906K.....6.5"71.95



CAST IRON SKILLET

Foundry seasoned, ready to use upon purchase. Use on all cooking surfaces, grills and campfires. Oven safe. Sauté, sear, fry, bake and stir fry to heart's content.

70-1902K.....6.5"26.95
70-1903K.....8"41.50
70-1904K.....10.25"57.75
70-1905K.....12"76.95



CAST IRON TRIVET/MEAT RACK

The Lodge trivet prevents scorching when used in the bottom of Dutch Ovens and Camp Dutch Ovens. 8.13" diameter.

70-1907K.....25.95



LODGE SEASONING SPRAY

Lodge cookware is known for lasting generations, but like any heirloom, our Cast Iron and Seasoned Steel require a little TLC to preserve that prized finish. Seasoning is an ongoing process that builds up with use and maintenance, giving you the familiar black patina that is naturally non-stick.

70-1900K.....8 fl.oz21.95



CAST IRON BAKE POT (NON-SEASONED)

70-036K.....8.5 qt138.95



PRE-SEASONED CAST IRON KETTLE

PLEASE NOTE: This kettle will rust if water is left in it.

70-003K3 qt88.95



BLACK OIL CAST IRON FRYING PAN

NON-SEASONED

70-2409K.....16"115.00

HOUSEWARES



STRAUSS TOUGH CASSEROLE POT

Eco-friendly. Cast-aluminum construction.
Not Dishwasher Safe.

70-2149K.....	2.6 Litre	59.95
70-2150K.....	4.5 Litre	80.95
70-2151K.....	7 Litre	99.95



ENAMEL ROASTERS

Complete with cover.

Oval

70-733K.....	11" x 7"	18.95
70-734K.....	13 1/2" x 9 1/2"	23.95
70-836K.....	17" x 14".....	30.95

Round

70-007K.....	9 3/4" x 5" Deep	18.95
--------------	------------------------	-------



ENAMEL STOCK POT

70-1089K.....	4 qt.....	23.95
70-1091K.....	8 qt.....	28.95
70-1092K.....	12 qt.....	36.95
70-1094K.....	21 qt.....	45.95



STRAUSS TOUGH FRYING PANS

Eco-friendly. Cast-aluminum construction.
Not Dishwasher Safe.

70-2145K.....	7.9" Dia.	41.95
70-2146K.....	9.5" Dia.	51.95
70-2147K.....	11" Dia.....	59.95
70-2148K.....	12.6" Dia.	79.95

find us on our
social media pages

See what's happening,
sales, promotions,
news & much more.

**SHOP 24/7 FROM
THE COMFORT OF
YOUR OWN HOME**

- Up to date Pricing
- New Products
- Stock Status
- Additional product info
- And more



www.mercersmarine.com



3 PC. DOUBLE BOILER SET

18/10 Stainless Steel for 100% safe cooking. Extra thick capsule bottom. Efficient and even heat transfer. Inside volume graduation. Tempered glass lid.

70-2232K7 1/2" Dia91.95



3 PC. STAINLESS STEEL STEAMER

Stainless steel with sandwich bottom and glass cover. 18 cm Diameter.

70-2248K91.95



STAINLESS STOCKPOTS

18/10 steel with sandwich bottom. Excellent product.

70-403K14 L127.50

NEW



JOSEF STRAUSS STAINLESS STOCKPOTS

The Strauss Pro Stockpot is made of the highest quality hand polished stainless steel with a satin band. The extra thick 3-ply capsuled bottom transfers heat quickly across the entire surface, resulting in even cooking. The stay-cool handles are oven-proof and the cookware is suitable for use on all heat sources, including induction. Dishwasher and oven safe.

70-2221K9 Litre121.95
 70-2222K14 Litre160.95
 70-2223K21 Litre186.95
 70-2224K24 Litre209.95
 70-2225K36 Litre341.95



STAINLESS STEEL ROASTER WITH LID

Comes with lid and removable roasting rack.

70-342K3 Qt42.95

70-405K9 Qt57.95



STAINLESS COLANDERS

2 convenient handles.

70-1197K3 qt10.95

70-1198K5 qt13.95

www.mercersmarine.com



- Always Open
- Sale & Feature items
- View Catalogue



- Thousands of products
- Updated Regularly
- Up to date Pricing



- Mobile Friendly
- Shop from anywhere at anytime

Also find us on    

Prices are subject to change. Check our website for up to date prices. www.mercersmarine.com



STAINLESS KETTLES

70-016K.....2L	57.95
70-018K.....4L	74.95
70-019K.....6L	99.95
70-020K.....8L	113.95



STAINLESS STEEL WHISTLING KETTLE

70-413K.....2.5 qt	18.30
--------------------------	-------



LARGE ALUMINUM KETTLES

70-326K.....5.5 L	27.95
-------------------------	-------



STAINLESS TEA POT

Beautifully shaped stainless steel tea pots.

70-069K.....32 oz.....	13.95
------------------------	-------



STAINLESS STEEL TEA POT WITH STRAINER

70-474K.....1.4 Litre	44.25
-----------------------------	-------



STAINLESS STEEL MIXING BOWLS

All purpose. Ideal bowls for making bread.

70-054K.....15.5" Dia. x 6" Deep.....	30.95
70-055K.....18" Dia. x 6" Deep	25.50



STAINLESS STEAMERS

Canteen pots •Newfoundlanders use them as pudding steamers.

70-043K.....6"	14.95
----------------------	-------



POTATO RICER

Canteen pots •Newfoundlanders use them as pudding steamers.

70-594K.....	13.95
--------------	-------



TIN PUDDING STEAMER

Old fashioned style.

70-153K.....1.5L.....	34.95
-----------------------	-------

TIMBERLINE S.S. COFFEE PERCOLATOR

The Timberline Coffee Percolator with its heavy gauge 18/8 polished stainless steel construction and heat insulating Perma wood handle makes perfect coffee at picnics, camp and home. This percolator has precision-fitting, seamless parts for brewing great coffee for years to come. Dishwasher-safe. Includes a quality storage sack with a drawcord closure.

20-2306M.....3 Cup	54.95
20-2307M.....6 Cup	64.95
20-2308M.....9 Cup	77.95
20-2309M.....12 Cup.....	88.95



The origin of MASON CASH pottery goes back to the 1800's. By the 1900's the company was producing domestic kitchenware in ceramics - the best known example of this line today is their traditional mixing bowls. This has become a classic and is recognized all over the world. Mason Cash is proud to be the only company making traditional mixing bowls, from traditional materials, in the traditional way.



TRADITIONAL MIXING BOWLS

70-2804K.....	8" diameter	40.95
70-2805K.....	9" diameter	51.95
70-2806K.....	10" diameter	65.95
70-2807K.....	11" diameter	73.95
70-2808K.....	12" diameter	88.95
70-2809K.....	13" diameter	115.95



GLASS LOAF PAN

70-404K.....5" x 9" (1.5 L)9.95



COOKIE SHEETS

Non-stick. Dishwasher safe.

70-2237K.....	10" x 15"	15.60
70-2238K.....	11" x 17"	19.95



SPRING FORM PANS

Non-Stick
Set of 2

70-657K.....8" & 10"17.50



6 CUP MUFFIN TOP PAN

If you like the top of the muffin the best, then you need these pans. Non-stick. Dishwasher safe.

70-2126K.....14" x 9 1/2"12.95



ROUND CAKE PAN

Non-stick. Dishwasher safe.

70-2236K.....9"10.95



Recipe for Tulip Cakes (Above)

For the shell, use regular cake mix. Fill shell 3/4 full of cake mix.

Mystery Filling

- 1/4 lb butter 1/2 cup sugar
- 2 tbsp. hot water 3 tbsp. flour
- 1 1/2 tbsp. milk 1 tsp. vanilla

Mix with mixer on med. speed for 2-3 min. Let stand 20 min. before using.

MADELINE PAN

70-2158K.....11.95



12 CUP DONUT MAKER

Non-stick. Dishwasher safe.

70-2234K.....13 1/2" x 10 1/4"25.95



TUBE PANS

70-746K.....	Top Measurements: 8.5"W x 3"H.....	15.40
	Bottom Measurements: 7" W x 3"H	
70-747K.....	Top Measurements: 10"W x 4"H.....	19.25
	Bottom Measurements: 8"W x 4"H	



PIZZA PAN

Non-stick. Dishwasher safe.

70-2240K15 1/2"16.95



PIZZA CRISPER

Non-stick. Dishwasher safe.

70-2241K.....14"19.95

NEW



MEATLOAF PAN

Non-stick. Dishwasher safe.

70-2239K.....9"17.50



BAGUETTE PAN

Non-stick. Dishwasher safe.

70-2235K.....15"19.95



PUDDING/CAKE MOULD

Non-stick. Dishwasher safe.

70-2102K8 1/2"12.60



MINI LOAF PAN

Makes up to 8 mini loafs. 13" x 9.5"

70-2159K.....22.95



12 CUP MIMI MUFFIN PAN

Non-stick. Dishwasher safe.

70-2254K7 1/2" x 10"12.95



LOAF PAN

Non-stick. Dishwasher safe.

70-2114K.....8"10.95

70-2115K.....9"13.95

70-2116K.....11"14.95

NEW



MINI SPRINGFORM PAN

70-2104K5" Dia12.95



Whether you are using a phone, tablet or laptop, our website is compatible with all devices.

www.mercersmarine.com



BERRY PICKERS

Makes berry picking easy. Easy to hold handle. Durable and lightweight plastic.

CHILD BERRY PICKER, PLASTIC COMB

70-1317K.....23.95

BERRY PICKER WITH WIRE COMB

70-1318K.....31.95



JAM FUNNEL

5" Diameter top. 1 1/4" diameter bottom

70-1315K.....11.95



BERRY CLEANUP TRAY

14" Diameter top.

70-1316K.....19.95



PUDDING BAGS

70-2403K.....Small.....2.95

70-2402K.....Large.....2.95



BREWIS BAG

Locally knit .Can be used for brewis, cabbage, greens and other veggies.

70-811K.....Small.....2.95

70-812K.....Large.....4.95



SAM'S BBQ SCRAPERS

Sam's Handcrafts takes pride in all its products and this BBQ scraper is no exception. Made from White Ash Wood, Juniper or Red Oak.

70-109J12" 15.95

70-110J14" 19.95



8 PIECE SEAFOOD SET

6 lobster picks and 2 shell crackers.

70-2106K.....29.95



ICE FISHING JIG

Locally made by Sam's Handcrafts. Comes with line and hook. 6" Long x 3 1/4" Wide.

20-424J.....7.95



LOBSTER & CRAB TOOLS

Ready for a feed of Lobster? These items are a must if you enjoy eating lobster or crab. Once you have used these shears, you won't know how you managed without them.

66-164KLobster shears.....26.50

66-165KLobster picks.....2.70





Our flags meet government specifications with their high-tenacity light nylon construction (many others do not!) •Brilliant satin appearance
•Vivid permanent dyes minimize fading •Lightweight, ensuring maximum flytime.



CANADA FLAGS

40-018P	9" x 18"	13.95
40-019P	12" x 24"	16.50
40-020P	18" x 36"	20.95
40-021P	27" x 54"	30.95
40-022P	36" x 72"	45.95



NEWFOUNDLAND AND LABRADOR FLAGS

40-023P	9" x 18"	19.95
40-024P	12" x 24"	23.95
40-025P	18" x 36"	43.95
40-026P	27" x 54"	56.95
40-027P	36" x 72"	84.95



UNION JACK FLAGS

40-029P	12" x 24"	23.95
40-030P	18" x 36"	43.95
40-031P	27" x 54"	56.95
40-032P	36" x 72"	84.95



RED ENSIGN

The Canadian Red Ensign is a former flag of Canada, used by the federal government though it was never officially adopted by the Parliament of Canada.

40-016P	18" x 36"	34.95
40-017P	27" x 54"	45.95



OLD NATIVE NEWFOUNDLAND FLAG

Old Native Newfoundland flag. (Not Flying Colours)

40-101K	9" x 18"	27.95
40-102K	12" x 24"	35.95
40-103K	18" x 36"	53.95
40-104K	27" x 54"	72.95
40-105K	36" x 72"	92.95



JOLLY ROGER FLAGS

40-042P	15" x 10"	24.95
40-043P	36" x 18"	41.95

www.mercersmarine.com



- Always Open
- Sale & Feature items
- View Catalogue



- Thousands of products
- Updated Regularly
- Up to date Pricing



- Mobile Friendly
- Shop from anywhere at anytime

Also find us on

A

Absorbents	
Oil Spill	264
Moisture	260
Accusharp.....	54,55
Acetone.....	247
Adaptors	
Bilge Pump	101
Insert, Bronze	92
Insert, Galvanized	95
Adhesive, Hull Liner.....	266
J-B Weld	262
Adjuster	
Hatch.....	129
Alarms	
Bilge	105
Carbon Monoxide.....	271
Fire	271
Anchors	
Ground	233
Sea	233
Anodes	87
Antennas	192-194
Aprons	56
Aquaseal	551
Augers, Ice	555
Axes (Fire).....	271
Axes (Woods).....	556

B

Bags	
Bait	31
Duffle, Waterproof.....	520
Gillnet	25
Sleeping	523-524,526-527
Balls, Trailer	227
Bamas Socks	513
Banders, Lobster	32
Bands, Lobster	32
Barbeques & Accessories.....	133-134
Barbs, Hose	92,112
Barometers	179
Baskets (Fishing).....	45
Batteries	168
Battery Clips	156
Battery Terminals & Insulators.....	164
Battery Trays.....	169
Bearings	
Flange	84
Pillow Block.....	84
Rubber Sleeve	85
Rudder Flange	83
Steady	83
Beds,Camp	525
Bellows, Exhaust	98
Bells, Ships	272
Belts, Leather	355

Shell	364
Belts, "V" and Link.....	91
Berry Pickers	567
Binders, Load	558
Binoculars	183-185
Blades, Circular Saw.....	246
Blankets, Survival	529
Blocks	29
Blowers, Bilge	177
Bollard, Stainless.....	232
Bolts	
Barrel	239
Carriage (Galv.)	7
Carriage (S.S.)	4
Eye	231
Hex Heads (S.S.).....	5
Ring.....	231
Screw Eye	231
U-Bolt,Stainless Steel.....	231
Books,Recipe, RV and ATV.....	522,560
Books, Log & Nav.	522
Books,Waterproof Note	182
Boots, See "Footwear"	
Boots, Motorwell.....	74
Bottles, Thermos	532-533
Bouffants	58
Bow Eyes.....	231
Bow Shield	255
Boxes	
Battery	169
Dry	267,517
Fish	30
Fly Fishing	45
Lunch Box.....	533-34
Rudder	83
Stuffing	85
Braces	307
Brackets	
Antenna	195
Axe	271,557
Clutch, Electric	15-16
Lifebuoy	268
Nav. Light Pipe	148
Outboard Motor	116-117
Pump, Hydraulic	15-16
Table	123
Breakers, electric circuit.....	162
Brooms,Deck	246
Brushes, Deck	246
Brushes (Paint)	248
Brushes (Wire).....	249
Bucket, Painting	248
Bucket, Fire	271
Bug Jackets etc.....	549
Bulbs	
Flood Light	143
LED	153
Navigation	148-152
Primer (O/B)	115

Searchlight	139-143
Bungy Cord	32
Buoys	26-28
Bus Bar	163
Bushing, Propeller.....	83
Button, Door	240

C

Cable	
Battery	165
Boat, Electric	156
Co-ax	193,195
Galv. Wire	29
Primary Wire	156
Stainless Steel Wire	29
Cables	
Engine Connection	81-82
Mechanical Steering	75
Cameras,	
Trail.....	185
Camping Supplies.....	517-556
Cans	
Diesel	114
Gas	113
Water	115
Caps	
Breather	19
Capstan.....	14
Carpeting,Trailer Bunk.....	228
Catches	
Cupboard.....	240
Door	240
Elbow	240
Caulking Gun.....	263
Chain	234
Chain Stopper	234
Chairs.....	119-122
Charts,Electronic.....	207-210
Chargers	
Battery	165,167
USB.....	157,160
Cheesecloth.....	522
Chocks	
Bow.....	232
Straight	232
Wheel	227
Clamps	
C-Clamp.....	558
Nylon Cable	156
Hose	98
Cleaners, Boat Care.....	255-261
Clearview	176
Cleats	232
Clinometer	181-182
Clips,	
Wire Rope	236
Clocks	179
Cloths, Micro Fiber	560
Clutches, Electric	16

Clothing and Accessories	
Camouflage	362-367
Canada Goose	372-382
Shop Coats	355
Work	302-340,344-360
Clothing, Snowmobile	
509	438-441
Edco	442-444
FXR	384-415
Klim	417-436
Compasses	180-181
Cones, Crab	31
Connectors	
Co-ax	195
O.B. Motor	112-113
Shore Power	171-174
Watertight Deck.....	157
Controls, Engine Connection	78-79
Converters.....	164
Cooksets	531,534,537
Coolers	
Hydraulic Oil	19
Keel.....	85
Drink Cooler	533
Cords	
Bungy	32
Extension.....	558
Shore Power	171
Corkline.....	21
Cots	525
Coupler, Trailer	227
Coupling	
Flexible Transmission.....	86
Lovejoy	83
Quick Disconnect	17
Split.....	84
Couplers	
Brass Hose to Pipe	92
Bronze Hose	92,94
Galvanized Hose	94-95
Coveralls	
Adults.....	306,321-323,336-337,345-354
Childrens	351-352
Disposable	249,346
Cylinders, Hydraulic	68-69,71-72

D

Day Shapes	272
Deck Plates.....	129-130
Defrosters	178
Detectors, Gas, Propane, etc.	271
Discs	
Hauler	10
Sanding	246
Dividers, Navigation	182

Docks-Floating Hardware	243-245
Dog Supples, Collars,Leashes,Vests	364
Doors	125
Drivelines	16
Drivesavers	86

E

Ear Muffs	342-343
Ear Plugs	342
Electronics	
Electronic Charts	207-210
GPS (Portable)	197-202
GPS (Plotters)	213-219
Radars.....	216,218-219,221
Satellite Communicators	
Inreach	196,199,200,202
Zoleo	196
Sounders	211-220
VHF.....	190-191
Engines	
Gas	14
Epirb	269
Exhaust	
Coating (Fire Resistant)	98
Lagging	98
Tape	98
Extinguishers, Fire.....	271

F

Fans	177-178
Fasteners	
Canvas Top	230
Hatch.....	240
S.S. & Galv.	4-7
Faucets	101
Fenders.....	28
Fiberglass	
Mat	247
Woven Roven.....	247
Fids, Splicing	25
Files	53,556
Fills, Deck Fuel.....	111
Fillers	
Epoxy Putty Sticks	262
Marine-Tex	263
Filters	
Dust / Mist	341
Fuel (Racor)	108-110
Sierra.....	110
Hydraulic	19
First Aid Kits	272,528
Fittings	
Brass Hose Barbs	92
Canvas Top	230
Co-ax	195
Fuel Line.....	112-113
Hydraulic	17-19

Keel Cooler	85
Outboard Hose.....	112
Pipe	94-95
Rail	229
Flags	230,568
Flag Holder	230
Flange, Transom Exhaust.....	98
Flaps, Rubber Exhaust	98
Flares and Rockets.....	267
Flashlights.....	270,538-540
Floats, (Gillnet, Scein)	26-27,30
Flotation Wear	
Dry Suits	273
Immersion Suits.....	274
Keyhole Life Jackets	275
Life Vests (P.F.Ds.).....	275-278
Life Vests (Inflatables)	279-282
Pants/Jackets	283-284
Survival Suits	285
Flushes, Outboard	115
Footrest, Seat	123
Footwear	449-513
Frames, Paint Roller	248
Funnels	115
Fuse, Blocks	161,163
Fuse Holders.....	163,165
Fuses	163,165

G

Gangions.....	33
Gauges	
Engine Panel	83
Fuel	80
Fuel Sender Kit	114
LED Gauges	167
Trim.....	80
Gaskets, Red Rubber	98
Gelcoat	247
Glasses,Safety	342
Sun	521
Gloves	
Chain Saw	65
Disposable	56
Fishing.....	57,59-63
Winter(& Mitts)	382,391,445-447
Work	64-65,306-307,328,356
Goggles.....	409-411,433,440
Gorilla Glue	265
G.P.S. (See Electronics)	
Grease	
Dielectric	158
Gun	254
Grinder	
Meat	560
Grippers, Ice Boot	484
Ground Plates	164
Gurdys and Parts	14

H

Hairnets & Beard	58
Hammerlocks	236
Hand Cleaners	264
Handles	
Axe	556
Hatch Lift.....	129
Lifting, Bow & Stern.....	230
Outboard Extension	117
Hasps, Door	238-239
Hatches	
Aluminum.....	127-129
Plastic Inspection	130
Skylights	129
Hats,	
Assorted	371
Hard	300,343
Fur	369-370
Haulers	
Fixed	9
Hanging Head	9-10
Lobster Pot	14
Parts	11
Head Lamps	539
Heaters	
Ceramic (12V)	178
Diesel	136
Engine Room	178
Hot Water	132
Maradyne	138
Parts & Accessories.....	138
Propane.....	136
Radex	138
Heaving Lines	268
Helmets	408-410,432,438-439,445
Helms	
Hydraulic	67,69-70
Mechanical	74
Power Steering	67
Hinges	240-242
Hoist, Rope	558
Holders	
Axe	557
Boat Hook	234
Chart	182
Door	238
Drink.....	122,205
Fender, Rope Holder	242
Fuse.....	165
Hand Held V.H.F.	189
High Amp Fuse.....	163
Lifebuoy	268
Rod,Fishing.....	41,229
Hooks	
Baited Rubber	34
Boat	234
Boning (Meat)	50

Clevis	237
Coat.....	242
Door	239
Feather.....	36-38
Fishing	39
Gaff	35,39
Grab	237
Locking	237
Pelican.....	237
Swivel	237
Horns	
Electric.....	175
Hand,Air.....	175,271,553
Oral.....	175,272
Hoses	
Bilge	96
Blower Vent.....	96
Fire	271
Freshwater	97
Fuel Line & Fill	96-97
Garden-Industrial	97,258
General Purpose	96
Hydraulic	19
Outboard Fuel Assembly	112
Outboard, Hydraulic	72
Toilet.....	96
Water Discharge	96-97
Hotpads	
Foot.....	445
Hand	445
Houseware.....	560-567
Hydrofoils/Stabilizers	73
Hydrostatic Release	267

I

Ice Augers	555
Ice Claws	554
Impellers.....	91
Insoles	452,483,491,512-514
Inverters	167
Isolators	
Battery	164
Galvanic.....	164

J

Jacks, Trailer	225
Jars, Bait	31
J.B. Weld Products.....	262
Jiggers	
Fishing	34-38
Squid.....	33

K

Keel Shield	255
Kettles	
Aluminum	564
Cast Iron	561
Kelly	536

Stainless Steel	531,564
Key	
Chains	240
Deck Fill	111
Kits	
Boating Safety	270
First Aid	272
Engine Control	81
Mechanical Steering	76
Inflatable Re-Arm	282
Survival	528-529
Kitchenware.....	560-567
Knee Pads	304,310,321,330
Knives	
Assorted	45-55
Drawing.....	556
Knobs	
Steering Wheel	77

L

Laces (Boot)	514
Ladders	118
Lagging, Exhaust.....	98
Lamps	
Brass Oil.....	154
Glass Oil.....	537
Globes	537
Wicks.....	537
Lanterns	530,537-539
Latch, Cabinet	240
Latch Sets	238
Lead Rope	25
Leads	
Barrel	30
Handline	35
Lifejackets-Keyhole	275
Lifebuoys	268
Lifelines, Heaving	268
Lights	
Cabin	153-155
Chart	153
Crab Pot.....	31
Dock Solar	244
Dome	154-155
Flashlights.....	270,538,540-541
Flood	143-147
Head	539
Lifebuoy	268
Navigation	148-152
Search	139-142
Strobe	268
Trouble	558
Vapor Proof	144
Water Activated.....	274
Lines	
Fishing	40
Mono.....	40
Trawl.....	33

Tuna Leader.....	33
Scein (Gangion)	33
Cork.....	21
Liners	
Boot	513
Hard Hat	320
Links, Quick	236
Lobster	
Escape Hatch	32
Heading Twine	32
Locks	
Hammer	236
Outboard Motor	117
Pad	238
Trailer Hitch	227
Locksets	238
Loops, Vented	106
Lugs, Battery	165
Lures, Fishing.....	34-38

M

Marker (Buoys)	27
Masks, Respirator	341
Matches, Safety.....	546
Matting/Anti-Fatigue	266
Mattress	525
Measures, Lobster & Crab	31-32
Mirrors	
Porthole	179
Safety Signal	542
Motors	
Electric Toilet Replacement	106
Hydraulic	12
Mouldings,Stainless Steel	229
Mounts	
Antenna	195
GPS (Ram).....	203-206

N

Nails	
Galvanized.....	7
Needles	
Net	25
Sail	21
Netting	
Bait Bag.....	31
Crab Pot.....	31
Scein	30
Nets,	
Beard & Hair	58
Cast	30
Dip (Trout).....	45
Fishing	25,30
Nozzle	
Fire	271
Garden Hose	97
Nuts	
Galvanized.....	7

Propeller	83
Stainless Steel	6
Thru-Hull Lock nuts	92

O

Oars	223
Oarlock, Horns & Sockets	224
Oil	
Fuel Treatment	253
SeaStar	70
Sierra Motor etc.	253-254
Teak	252
O'keefe's Cream.....	264
Outlets, Deck.....	157

P

Packing, Stuffing Box	84
Pack Sacks	364,414,434,517-520
Marine Sacks	520
Paddles	223
Pad Eyes	234
Pads	
3M Buffing.....	259
Scouring	58
Paint, Solvents, etc.....	249-252
Paint Trays	247
Palms, Sail.....	21
Panels	
Bilge Pump	105
Electrical.....	159-161
Engine Instrument.....	83
Pants	
Chain Saw	356
Flotation (See Flotation Wear)	
Pedestals	
Seat	119,123-124
Table	123
Pins	
Clevis.....	6
Cotter	83
Hair (Hitch-type)	557
Linch	557
Quick	557
Pipe,K-Copper	85
Plates	
Camping	535,537
Chain / Rope Deck	232
Hawse	232
PLB (Personal Locator Beacon).....	269
Pliers, Hog Ring.....	33
Plugs, Drain.....	235
Pole	
Flag	230
Wooden Paint	248
Polishes	
Marine	255-261
Ports (Portholes)	126
Pots, Crab	31

Power	
Marinco (Shore Power)	171-174
Packs (Hydraulic)	14
Sockets	157
Supply	164
Puller, Ratchet.....	558
Pulleys	
Nylon.....	242
Stainless Steel	242
"V" Belt	91
Pulls, Hatch	130,242
Pumps	
Barrel	105
Bilge.....	102-104
Electric Clutch	90
Electric Drill	105
Engine Oil Change	105
Flexible Impeller	90
Fuel (Stove)	137
Galley, Hand	100
General Purpose	102
Hand Bilge.....	104
Hydraulic.....	15
Hydraulic Steering	67
Inflation	104,553
Live Well	103
Macerator	106
Pacer	88
Shower Drain	105
Pressure Water System	99-100
Vane.....	89-90
Washdown	88,90
Water Puppy	90

R

Racor Products	108-110
Radars	216,218-219,221
Radios	
AM/FM/Sirius	187-189
Two-Way	191
V.H.F.	190-191
V.H.F. (Handheld)	190-191
Rags, Cleaning.....	262
Railings, S. S.....	229
Rails,Stainless Steel.....	230
Rain Clothes	287-302
Reels, Jigging,Cod,Salmon	40,42-44
Reflectors,Radar	27,269,272
Reflective Bands & Sash.....	330
Refrigerators	132
Relays (Charging)	161
Resins and Hardeners	247
Fiberglass	247
Respirators	341
Rings	
Hog	33
Jigger	34
Lobster	32

On Plate.....	232
Purse Scein	30
Stainless Steel	236
Rivets, Stainless Steel	6
Rockets, Flares.....	267
Rods	
Cod.....	41-42
Fly Fishing	44
Ice Fishing	555
S.S. Threaded.....	4
Rollers	
Anchor	233
Fairlead	10
Fiberglass Steel	247
Gillnet	14
Refills, Paint	248
Squid.....	33
Rope	20-22
Rope (Life Ring).....	21
Rules, Parallel	182
Runners, Poly Sled.....	557

S

Sanding (Assorted Products)	
Discs, Pads, Paper, etc.....	246
Saws,	
Blades	246
Coghlans	545
Meat	50
Scales	
Pocket	40
Salter.....	30
Screws	
Galvanized Lag	7
S. S. Flat Head.....	4-5
S. S. Lag.....	4
S. S. Machine	5
S. S. Pan Head	4
Scuppers, Bronze	234
Sealants, Adhesive	263
Seats, Boat	119-122
Senders,	
Fuel Float.....	114
Oil Pressure & Temp.	80
Shackles	236
Sharpeners, Accusharp Knife & Tool	53-54
Shoe Covers.....	58
Shoe-goo.....	510
Shoe Horns	483
Shovels	
Fish Plant	33
Folding	545
Steel	33,553
Sinks	101
Skivers, Crab Pot	31
Sleeves	
Arm	57,287
Drain	235
Slide, Seat	123

Smoke Signal.....	267
Snaps	
Eye	237
Fastener (Canvas)	230
Snowshoes & Slings.....	554
Socks	305,318,483,513
Sounders	211-220
Souwesters	296
Speakers	
V.H.F., C.B. & Hailer	194
Stereo.....	187-189
Speedometers	80
Spikes	
Marlin	25
Ships Galvanized	7
Spray-Animal Deterrent.....	522
Stabilizers (Hydrofoils)	73
Staples, Mooring	232
Steels, Sharpening	47,49,53-55
Steering	
Hydraulic	69-72
Mechanical	74-75
Power (Hydraulic)	68
Stereos.....	187-189
Steps, Folding	238
Stones (Sharpening).....	53-55
Stops, Door	238,240
Stoves	
Camp	530,545
Diesel Burning	135
Parts, Stove	137
Propane	135-136
Strainers	
Galley Water	100
Water Intake, Bronze	89
Straps,	
Winch	225
Sunglasses.....	521
Suspenders	355
Switches	
Battery Disconnect.....	170
Battery Selector	170
Bilge Pump	103
Ignition	158
Ignition Kill, O.B.	158
Push Button	158,164
Push-Pull	158
Rocker	158
Toggle.....	158,164
Swivels	
Eye & Eye	237
Jaw & Eye	237
Jigger	34,37
Nylon.....	32
Seat	123-124
Trawl.....	33

T

Table	525
Tachometers	80

Tanks	
Accumulator	100
Hot Water	132
Hydraulic	19
Outboard	113-114
Portable Gas	115
Tape	
Anti-Corrosion	19
Duct.....	266
Electric.....	165
Exhaust	98
Flagging	522
Freeze-Fix Fiberglass	262
Gorilla	265
Masking.....	249
Measuring	558
Reflective	267
Safety Walk	266
Teflon	95
Tarpaulins	553
Terminals	
Battery	156,165
Wire	156,165
Thermos	532-533
Thimbles	236
Thru-hulls	92-93
Tie Bars, O/B Steering	71
Ties, Wire	156
Tiller Arm	69
Toilets	106-107
Toe Straps	558
Trailer Boat Guides	228
Trailer Lights	228
Trailer Rollers & Acc	226-227
Transom Savers	117
Trim Tabs	73
Trawl Line	33
Tubing	
Heat Shrink	156
SeaStar, Nylon	71
Soft Copper	69
Stainless Steel	229
Turnbuckles.....	231
Twines	23-24

V

Valves	
Ball	89
Check	92,101
Flow Control	13
Foot.....	97
Hydraulic Control	13
"Y" Valve	106
Vented Loops	106
Vents	
Cowl	131
Fuel Fill	111
Louvered	131
Roof.....	131

Vests
 Safety328-331
 V-Belts91
 VHF Radios190-191
 V-Notcher, Lobster32

W

Washers
 Galvanized7
 S. S. Finish4
 S. S. Flat & Lock6
 Waterproofing, Canvas261
 Wax, Fibreglass256-259
 Wharfs (Floating Hardware)243-245

Wheels
 Metal Cut-off246
 Steering77
 Whistles,270
 Winches (Trailer)225
 Windows126
 Windshield Support Bar175
 Wipers & Accessories176
 Wire, Snare (Rabbit)522
 Wrapping, Exhaust98
 Wrecking Bar7

Z

Zincs87

HOW TO FIND US

Clarenville How to find us.
 Exit 230-A to Memorial Drive then take right to Marine Drive. Can't miss us.
 or Exit to Manitoba Drive. Take right onto Memorial Drive. Take left onto Vardys Ave. We are located on the corner of Vardys Ave. & Marine Drive.
Follow route highlighted in Yellow.



ACTON®

Where the action is



PRAIRIE
A3670-10



MERCER'S

Quality & Service Since 1957

210 Marine Drive, Clarenville
Newfoundland & Labrador

A5A 1L8, Canada

Tel: 709.466.7430

Fax: 709.466.3279

Email: info@mercersmarine.com

Shop Online:

www.mercersmarine.com